

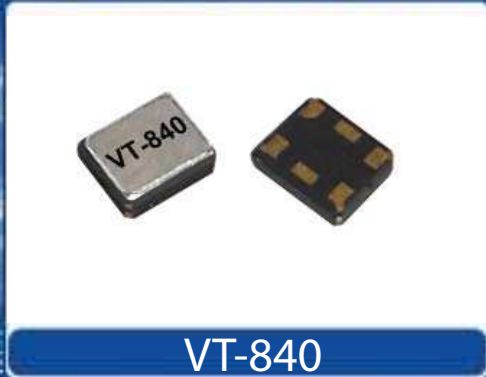

Helping Customers Innovate, Improve & Grow



VT-840

Description

Vectron's VT-840 Temperature Compensated Crystal Oscillator (TCXO) is a quartz stabilized, clipped sine wave output, analog temperature compensated oscillator, operating off a 1.8, 2.5, 2.8, 3.0 or 3.3 volt supply in a hermetically sealed 2.5x2.0 ceramic package.

Features

- Output Frequencies to 52 MHz
- ± 0.5 ppm Temperature Stability
- Fundamental Crystal Design
- Optional VCXO Function available
- Low Power
- Hermetically Sealed Ceramic SMD package
- Product is compliant to RoHS directive  and fully compatible with lead free assembly

Applications

- Wireless Communications
- GPS
- Base Stations
- Point to point radios
- Broadband Access
- Test Equipment
- Handsets

Block Diagram

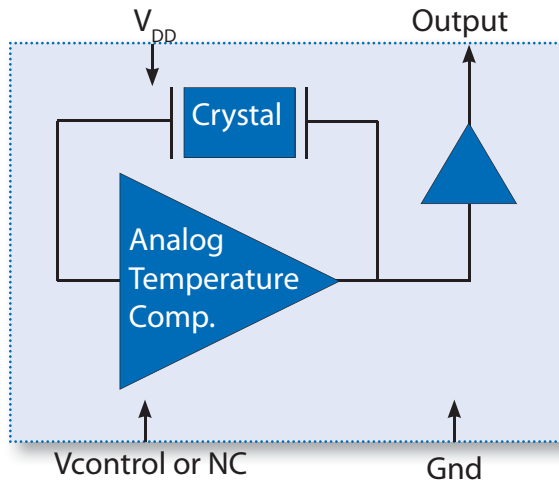

Specifications

Table 1. Electrical Performance

Parameter	Symbol	Min.	Typ	Max	Units
Output Frequency	f_o	10.000		52.000	MHz
Supply Voltage ¹ , <i>ordering option</i>	V_{DD}	+1.8, +2.5, +2.8, +3.0, +3.3			V
Supply Current, 10.000 to 26.000MHz 26.001 to 52.000MHz	I_{DD}			2.0 2.5	mA mA
Operating Temperature, <i>ordering option</i>	T_{OP}	-20/70, -30/85, -40/85			°C
Stability Over TOP, <i>ordering option</i>		±0.5, ±1.0, ±1.5, ±2.0, ±2.5			ppm
Initial Accuracy ² , "No Adjust" Option				±1.0	ppm
Power Supply Stability				±0.2	ppm
Load Stability				±0.2	ppm
Aging				±1.0	ppm/1st yr
Pull Range, <i>ordering option</i>	TPR	±5, ±8, ±10, ±12			ppm
Control Voltage to reach Pull Range, 1.8V option +2.5V, +2.8V, +3.0V and +3.3 V options		0.3 0.5		1.5 2.5	V V
Control Voltage Impedance		500			Kohm
Output Level ³	V_o p/p	0.8			V
Output Load			10K 10pF		
Phase Noise, 26.000MHz 10Hz 100Hz 1kHz 10kHz 100kHz			-85 -110 -130 -148 -148		dBc/Hz
Start Up Time				2	ms

1. The VT-840 power supply pin should be filtered, eg, a 0.1 and 0.01 uf capacitor
2. Initial Accuracy is before IR reflow, allow and additional 1ppm shift through 2 reflows and 24 hours.
3. The Output is DC coupled and would normally be AC coupled with a capacitor.

Outline Drawing

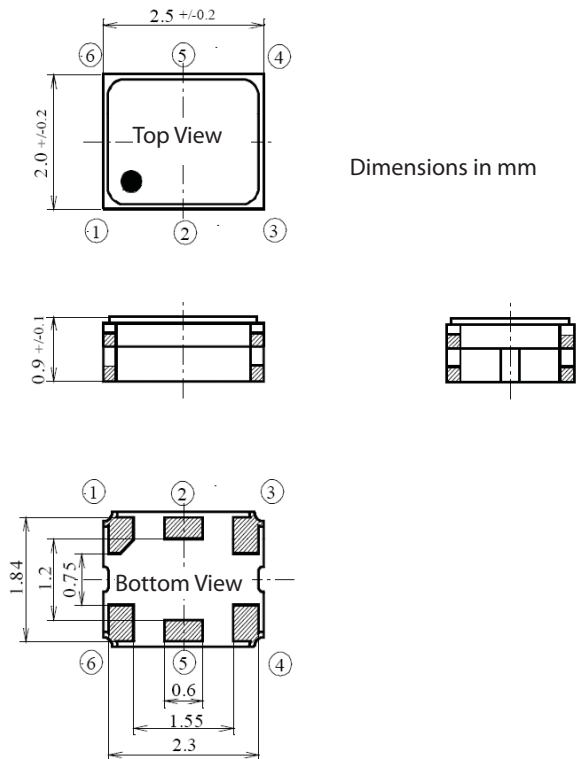

Recommended Pad Layout

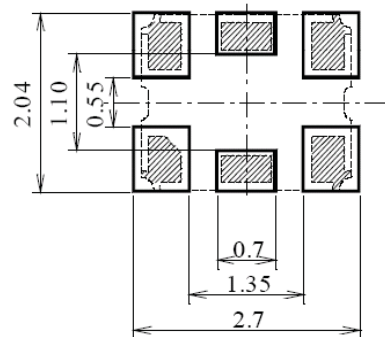

Table 2. Pinout

Pin #	Symbol	Function
1	V_C	TCXO Control Voltage or Ground
2	NC	Make No Connection
3	GND	Electrical and Lid Ground
4	F_o	Output Frequency
5	NC	Make No Connection
6	V_{DD}	Supply Voltage

VCXO Function

VCXO Feature: The VT-840 can be ordered with a VCXO function for applications where it will be used in a PLL, or the output frequency needs fine tune or calibration adjustments. This is a high impedance input, 500 Kohm, and can be driven with an op-amp or terminated with adjustable resistors etc. **Pin 1 should not be left floating on the VCXO optional device.**

“No Adjust” Option: In applications where the VT-840 will not be used in a PLL, or the output frequency does not need fine tune adjustments, the best device to use would be a VT-840-xxx-xxx0. By using the “no adjust” option, the circuit is simplified as V_c does not need to be adjusted or set to a predetermined voltage and pin 1 should be grounded (pin 1 can be left open but should not be set to a voltage such as an RF signal or power supply voltage).

Clipped Sine Wave Output



Maximum Ratings

Absolute Maximum Ratings and Handling Precautions

Stresses in excess of the absolute maximum ratings can permanently damage the device. Functional operation is not implied or any other excess of conditions represented in the operational sections of this data sheet. Exposure to absolute maximum ratings for extended periods may adversely affect device reliability.

Although ESD protection circuitry has been designed into the VT-840, proper precautions should be taken when handling and mounting, VI employs a Human Body Model and Charged Device Model for ESD susceptibility testing and design evaluation.

ESD thresholds are dependent on the circuit parameters used to define the model. Although no industry standard has been adopted for the CDM a standard resistance of 1.5kOhms and capacitance of 100pF is widely used and therefore can be used for comparison purposes.

Table 3. Maximum Ratings			
Parameter	Symbol	Rating	Unit
Storage Temperature	T_{STORE}	-55/125	°C
Supply Voltage	V_{DD}	-0.6 to 6	V
Control Voltage	V_C	0/ V_{DD}	V
ESD, Human Body Model	HBM	1500	V
ESD, Charged Device Model	CDM	100	V

Table 4. Environmental Compliance	
Parameter	Condition
Mechanical Shock	MIL-STD-883 Method 2002
Mechanical Vibration	MIL-STD-883 Method 2007
Temperature Cycle	MIL-STD-883 Method 1010
Solderability	MIL-STD-883 Method 2003
Fine and Gross Leak	MIL-STD-883 Method 1014
Resistance to Solvents	MIL-STD-883 Method 2015
Moisture Sensitivity Level	MSL1
Contact Pads	Gold (0.5um min - 0.8um max) over Nickel

IR Reflow

Suggested IR Profile

Devices are built using lead free epoxy and can be subjected to standard lead free IR reflow conditions shown in Table 5. Contact pads are gold over nickel and lower maximum temperatures can also be used, such as 220C.

Table 5. Reflow Profile		
Parameter	Symbol	Value
PreHeat Time Ts-min Ts-max	t_s	200 sec Max 150°C 200°C
Ramp Up	R_{UP}	3°C/sec Max
Time above 217C	t_L	150 sec Max
Time to Peak Temperature	$t_{25C \text{ to peak}}$	480 sec Max
Time at 260C	t_p	10 sec Max
Time at 240C	t_{p2}	60 sec Max
Ramp down	R_{DN}	6°C/sec Max

Solderprofile:

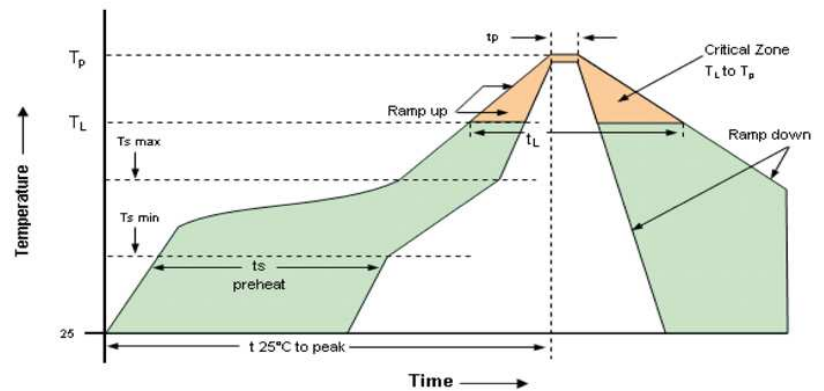

Tape & Reel

Table 6. Tape and Reel Information

Tape Dimensions (mm)						Reel Dimensions (mm)						
W	F	Do	Po	P1	A	B	C	D	N	W1	W2	#/Reel
8.0	3.5	1.5	4.0	4.0	180	2.0	13	21.0	60.0	9.0	11.4	

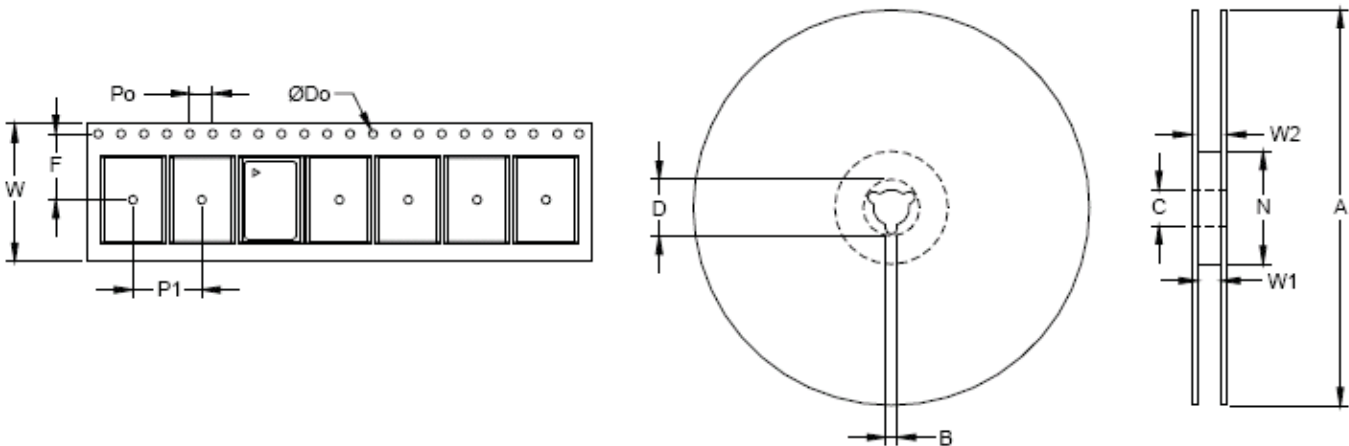

Ordering Information

Table 7. Standard Frequencies (MHz)

10.000	10.240	12.000	12.8000	14.000	14.400	16.000	16.369	161.384	16.800
19.200	20.000	24.000	25.000	25.6000	26.000	30.000	31.250	32.000	38.400
39.000	40.000	42.000	44.000	45.000	48.000	50.000	52.000		

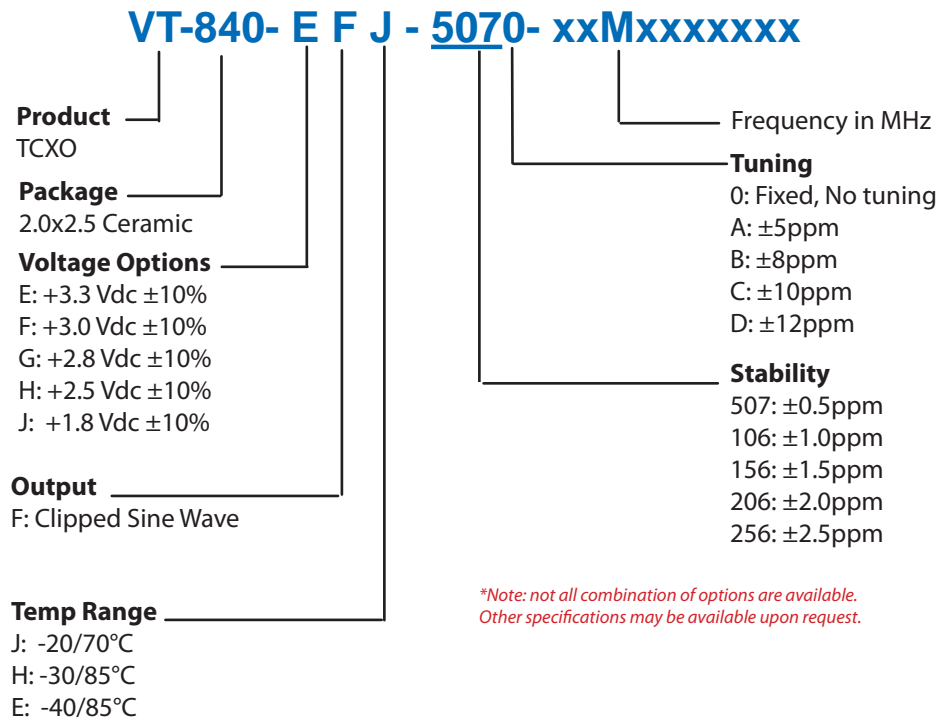

Example: VT-840-EFJ-5070-26M0000000

For Additional Information, Please Contact

USA:

Vectron International
267 Lowell Road
Hudson, NH 03051
Tel: 1.888.328.7661
Fax: 1.888.329.8328

Europe:

Vectron International
Landstrasse, D-74924
Neckarbischofsheim, Germany
Tel: +49 (0) 3328.4784.17
Fax: +49 (0) 3328.4784.30

Asia:

VI Shanghai
1589 Century Avenue, the 19th Floor
Chamtime International Financial Center
Shanghai, China
Tel: 86.21.6081.2888
Fax: 86.21.6163.3598

Disclaimer

Vectron International reserves the right to make changes to the product(s) and or information contained herein without notice. No liability is assumed as a result of their use or application. No rights under any patent accompany the sale of any such product(s) or information.

Rev: 03/30/2012