

Helping Customers Innovate, Improve & Grow



### Features

- Ultra Low G-Sensitivity
- Low Phase Noise
- High Stability
- Vectron's Patented (US Patent 6,984,925) QRM Crystal Technology
- Frequency Range: 3 MHz to 20 MHz
- Vibration Compensation

### Applications

- Military Avionics
- Airborne Radar
- Test Equipment
- Frequency Synthesizers
- Position Location
- Satellite Communications

### Performance Specifications

Parameter	Min	Typ	Max	Units	Condition
Available Frequencies					
With Standard Crystals	3		20	MHz	
With QRM Crystals	8		15	MHz	
G-Sensitivity Performance					
G Sensitivity w\std. crystal $\geq 10$ MHz			1.0	ppb/g	Degrades to 2.0 ppb/g @ 3 MHz
G Sensitivity w\QRM crystal $\geq 10$ MHz			0.2	ppb/g	Degrades to 0.4 ppb/g @ 8 MHz
G Sensitivity w\std crystal & vibration compensation $\geq 10$ MHz			0.1	ppb/g	Degrades above 200 Hz
G Sensitivity w\QRM crystal & vibration compensation $\geq 10$ MHz			0.02	ppb/g	Degrades above 200 Hz
(No mechanical resonances out to 2KHz)					G sensitivity specified per axis
Frequency Stabilities <sup>1</sup>					
vs. operating temperature range (referenced to +25°C)	-30		+30	ppb	-40... +85°C
	-20		+20	ppb	-40... +70°C
	-10		+10	ppb	-20... +70°C
	-5		+5	ppb	0... +70°C
Initial Tolerance	-50		+50	ppb	at time of shipment, nominal EFC
vs. supply voltage change	-2.0		+2.0	ppb	Vs $\pm 5\%$
vs. load change	-2.0		+2.0	ppb	Load $\pm 5\%$
vs. aging / daily	-0.5		+0.5	ppb	after 72 hours of operation
vs. aging / 1 year	-40		+40	ppb	after 72 hours of operation
vs. aging / year (following years)	-30		+30	ppb	

## Performance Specifications

Parameter	Min	Typ	Max	Units	Condition
Warm-up Time			5	minutes	to $\pm 10$ ppb of final frequency (1 hour reading) @ +25°C
<b>Supply Voltage (Vs)</b>					
Supply voltage (Standard-Opt A)	14.25	15.0	15.75	VDC	18 & 24 VDC options available
Supply voltage (Standard-Opt B)	11.25	12.0	12.75	VDC	18 & 24 VDC options available
Oven Power Consumption			12.0 3.0	Watts Watts	during warm-up steady state @ +25°C
<b>RF Output</b>					
Signal	Sinewave				
Load		50		ohm	
Output Power	+6.0	+7.0	+8.0	dBm	50 ohm load
Harmonics			-30	dBc	50 ohm load
<b>Frequency Tuning (EFC)</b>					
Tuning Range	$\pm 0.5$	$\pm 0.8$	$\pm 2.0$	ppm	Electronic frequency control
Linearity			20	%	
Tuning Slope	Positive				
Control Voltage Range	0.0	+4.0	+8.0	VDC	
<b>Mechanical Trim (Internal)</b>					
Tuning Range	$\pm 0.75$	$\pm 1.0$	$\pm 2.0$	ppm	Internal Mechanical
<b>Additional Parameters<sup>1</sup></b>					
Phase Noise <sup>3</sup> (@5 MHZ) (under static conditions - no vibration)		-115	-105	dBc/Hz	1 Hz
		-140	-137	dBc/Hz	10 Hz
		-155	-152	dBc/Hz	100 Hz
		-166	-163	dBc/Hz	1 KHz
		-168	-165	dBc/Hz	10 KHz
Phase Noise <sup>3</sup> (@ 10 MHZ) (under static conditions - no vibration)		-100	-95	dBc/Hz	1 Hz
		-130	-127	dBc/Hz	10 Hz
		-155	-152	dBc/Hz	100 Hz
		-166	-163	dBc/Hz	1 KHz
		-168	-165	dBc/Hz	10 KHz
Weight			100	g	
<b>Absolute Maximum Ratings</b>					
Supply voltage (Vs)			28	V	
Output Load	short		open	ohm	
Operable temperature range	-55		+85	°C	
Storage temperature range	-55		+125	°C	
<b>Environmental Specifications</b>					
Shock - operating	MIL-STD-202, Method 213, Condition J, 30G, 11ms, half sine				
Shock - endurance	Mil-STD-202, Method 213, Condition C, 100G, 6ms, half sine				
Sine Vibration - operating	Mil-STD-202, Method 204, Condition C, 10 G				
Sine Vibration - endurance	Mil-STD-202, Method 204, Condition D, 20 G				
Random Vibration - operating	Mil-STD-202, Method 214, Condition I-C, 9.26 Grms (without vibe comp) Mil-STD-202, Method 214, Condition I-A, 5.35 Grms (with vibe comp)				
Random Vibration - endurance	Mil-STD-202, Method 214, Condition I-H, 29.28 Grms				
Seal	Mil-STD-202, Method 112, Condition D (not applicable to units with SMA connector)				

# Outline Drawing / Enclosure

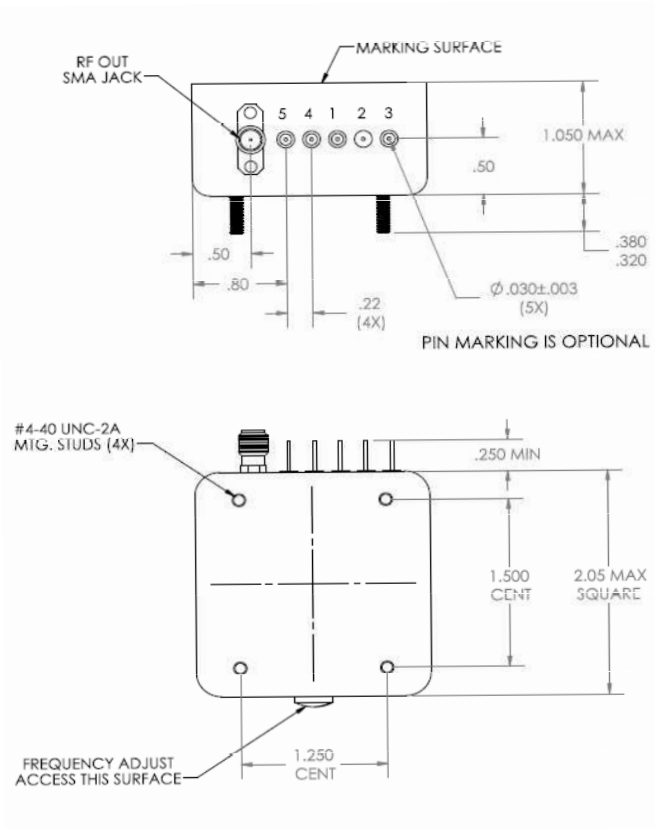

Dimensions in inches

Type A		
Code	Height "H" max	
0	1.05	

Pin Connections	
1	Electronic Frequency Control (EFC)
2	Ground (Case)
3	Supply Voltage
4	Vectron Internal Use Only / NC
5	Vectron Internal Use Only / NC

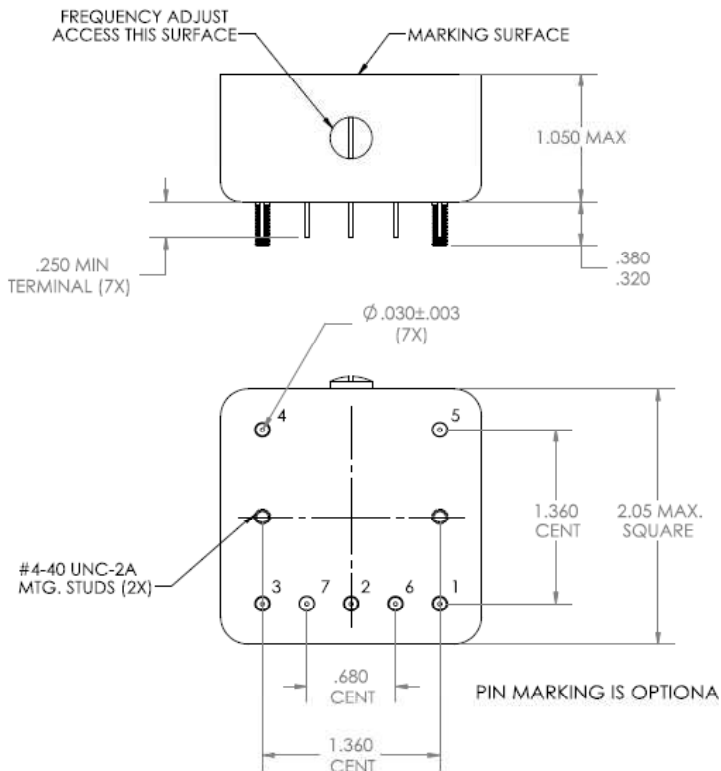

Type B		
Code	Height "H" max	
1	1.05	

Pin Connections	
1	Electronic Frequency Control (EFC)
2	Vectron Internal Use Only / NC
3	RF Output
4	Ground (Case)
5	Supply Voltage
6	Vectron Internal Use Only / NC
7	Ground (Case)

## Ordering Information

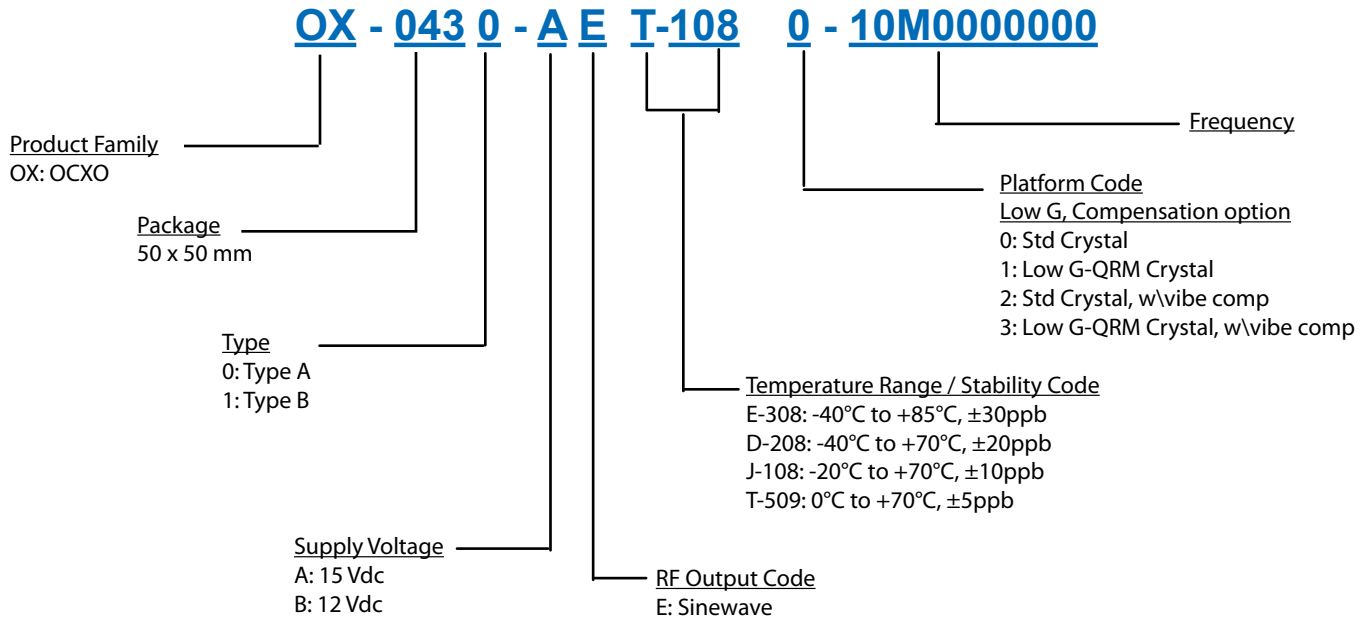

**Notes:**

1. Contact factory for improved stabilities or additional product options. Not all options and codes are available at all frequencies.
2. Unless other stated all values are valid after warm-up time and refer to typical conditions for supply voltage, frequency control voltage, load, temperature (25°C).
3. Phase noise degrades with increasing output frequency.
4. Subject to technical modification.
5. Contact factory for availability.

## For Additional Information, Please Contact

**USA:**

Vectron International  
267 Lowell Road  
Hudson, NH 03051  
Tel: 1.888.328.7661  
Fax: 1.888.329.8328

**Europe:**

Vectron International  
Landstrasse, D-74924  
Neckarbischofsheim, Germany  
Tel: +49 (0) 3328.4784.17  
Fax: +49 (0) 3328.4784.30

**Asia:**

Vectron International  
1F-2F, No 8 Workshop, No 308 Fenju Road  
WaiGaoQiao Free Trade Zone  
Pudong, Shanghai, China 200131  
Tel: 86.21.5048.0777  
Fax: 86.21.5048.1881

**Disclaimer**

Vectron International reserves the right to make changes to the product(s) and or information contained herein without notice. No liability is assumed as a result of their use or application. No rights under any patent accompany the sale of any such product(s) or information.

Rev: 8/11/2011 drs