

Helping Customers Innovate, Improve & Grow



### Description

The EX-400 provides exceptionally low aging rates and tight temperature stabilities in an extremely small package over a wide range of environmental conditions. This EMXO series bridges the gap between current large, high precision OCXO's and smaller TCXO's. The EX-400 Series becomes the most economical choice where there is a need for spectral purity, short and long term stability, along with small size and dramatically reduced power consumption.

### Features

- 4-Pin Dip
- Uses Doubly Rotated Crystal
- Low Power Consumption: <0.35 watts @ +25°C
- Previous Model Number: EX-380, EX-381, EX-385 series
- Frequency Range: 10 MHz - 80 MHz

### Applications

- SONET/SDH, DWDM, FDM, ATM, 3G
- Telecom Transmission and Switching Equipment
- Wireless Communication Equipment
- Military Airborne and Mobile systems

### Performance Specifications

Frequency Stabilities <sup>1</sup>					
Parameter	Min	Typ	Max	Units	Condition
vs. operating temperature range (referenced to +25°C)	-75		+75	ppb	-20... +70°C (10 to 20.49 MHz)
	-100		+100	ppb	-20... +70°C (10 to 50 MHz)
	-100		+100	ppb	-40... +85°C (10 to 20.49 MHz)
	-150		+150	ppb	-20... +70°C
	-150		+150	ppb	-40... +85°C
	-150		+150	ppb	-55... +85°C (10 to 50 MHz)
	-250		+250	ppb	-20... +70°C
	-250		+250	ppb	-40... +85°C
	-250		+250	ppb	-55... +85°C
	-500		+500	ppb	-20... +70°C
	-500		+500	ppb	-40... +85°C
	-500		+500	ppb	-55... +85°C

# Performance Specifications

Frequency Stabilities <sup>1</sup>						
Parameter		Min	Typ	Max	Units	Condition
vs. Stratum 3 per GR-1244- CORE	Operating Temp	-140		+140	ppb	-20... +70°C
	Holdover	-140		+140	ppb	-40... +85°C (10 to 50 MHz)
	Drift	-140		+140	ppb	-55... +85°C (10 to 20.49 MHz)
	MTIE	-370		+370	ppb	24 hours
		-4.63		+4.63	10-13/sec ppm	Over 7100 seconds 0.16sec < Observe Times < 64 sec
Warm-up Time				1 2	minutes minutes	to ± 1ppm of final frequency (1 hour) to ± 100ppb of final frequency (1 hour)
Initial Tolerance (10 to 19.9 MHz)		-1.0		+1.0	ppm	for fixed frequency
Initial Tolerance (20 to 80 MHz)		-1.5		+1.5	ppm	for fixed frequency
vs. supply voltage change (10 to 50 MHz)		-2.5		+2.5	ppb	VS ± 5%
vs. supply voltage change (50 to 80 MHz)		-5.0		+5.0	ppb	VS ± 5%
vs. load change (10 to 80 MHz)		-15		+15	ppb	Load ± 5%
vs. aging / day (10 to 14.9 MHz)		-1.0		+1.0	ppb	after 30 days of operation
vs. aging / day (15 to 19.9 MHz)		-2.0		+2.0	ppb	after 30 days of operation
vs. aging / day (20 to 49.9 MHz)		-3.0		+3.0	ppb	after 30 days of operation
vs. aging / day (50 to 80.0 MHz)		-4.0		+4.0	ppb	after 30 days of operation
vs. aging / 1 year (10 to 14.9 MHz)		-200		+200	ppb	after 30 days of operation
vs. aging / 1 year (15 to 19.9 MHz)		-300		+300	ppb	after 30 days of operation
vs. aging / 1 year (20 to 80 MHz)		-500		+500	ppb	after 30 days of operation
vs. aging / 10 year (10 to 14.9 MHz)		-1000		+1000	ppb	after 30 days of operation
vs. aging / 10 year (15 to 19.9 MHz)		-2000		+2000	ppb	after 30 days of operation
vs. aging / 10 year (20 to 80 MHz)		-3000		+3000	ppb	after 30 days of operation
Supply Voltage (Vs)						
Supply voltage (Standard)		4.75	5.0	5.25	VDC	
Supply voltage (Option)		3.135	3.3	3.465	VDC	
Power Consumption				1.5	Watts	during warm-up
				0.35	Watts	steady state @ +25°C (10 to 29.99 MHz)
				0.45	Watts	steady state @ +25°C (30 to 80 MHz)
				0.7	Watts	steady state @ -40°C (10 to 29.99 MHz)
				0.8	Watts	steady state @ -40°C (30 to 80 MHz)
RF Output						
Signal [Standard]		HCMOS				
Load			15		pF	
Signal Level (Vol)				0.4	VDC	
Signal Level (Voh)		0.8			VDC	
Rise/Fall Time				+5	ns	(10-80%)
Duty cycle		40		60	%	(Voh-Vol)/2
Signal [Option]		Sinewave				
Load			50		ohm	
Output Power [Standard]		0		+4	dBm	50 Ohm load
Output Power [Option]		+3		+7	dBm	50 Ohm load

Frequency Stabilities <sup>1</sup>					
Parameter	Min	Typ	Max	Units	Condition
<b>Frequency Tuning (EFC)</b>					
Tuning Range	Fixed OCXO; No adjust				
Tuning Range	±1.0 ±2.0 ±3.0 ±4.0		±5.0 ±8.0 ±10.0 ±12.0	ppm ppm ppm ppm	with 10 to 14.99 MHz with 15 to 20.48 MHz with 20.5 to 49.99 MHz with 50 to 80 MHz
Control Voltage Range	0		Vdd	VDC	
Tuning Slope	Positive				
<b>Additional Parameters</b>					
Phase Noise @ 20 MHz (Typical)			-100	dBc/Hz	10 Hz
			-130	dBc/Hz	100 Hz
			-140	dBc/Hz	1 KHz
			-145	dBc/Hz	10 KHz
			-150	dBc/Hz	10 KHz
Phase Noise @ 50 MHz (Typical)			-80	dBc/Hz	10 Hz
			-110	dBc/Hz	100 Hz
			-130	dBc/Hz	1 KHz
			-135	dBc/Hz	10 KHz
			-140	dBc/Hz	10 KHz
Allan Deviation			0.2	ppb	Tau = 1 sec to 10 sec (10 to 20.49 MHz)
			0.5	ppb	Tau = 1 sec to 10 sec (20.5 to 80 MHz)
Weight			5	g	
<b>Absolute Maximum Ratings</b>					
Supply Voltage			5.5	VDC	with Vs=5 V
			5.5	VDC	with Vs=3.3 V
Output Load			30	pF	
Operable temperature range	-55		+85	°C	
Storage temperature range	-55		+85	°C	

## Outline Drawing / Enclosure

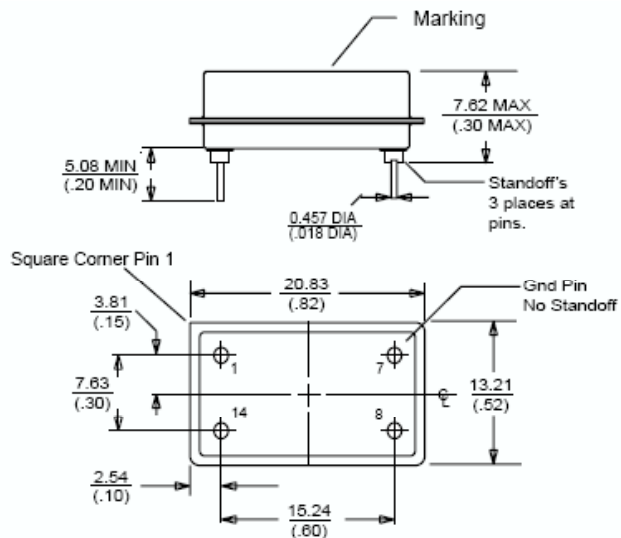

Dimensions in mm (inches)

Type A		
Code	Height "H"	Pin Length "L"
0	7.62	5.08

Pin Connections	
1	EFC \ No Connect \ Oven Monitor
7	Ground (Case)
8	RF Output
14	Supply Voltage Input

## Outline Drawing / Enclosure

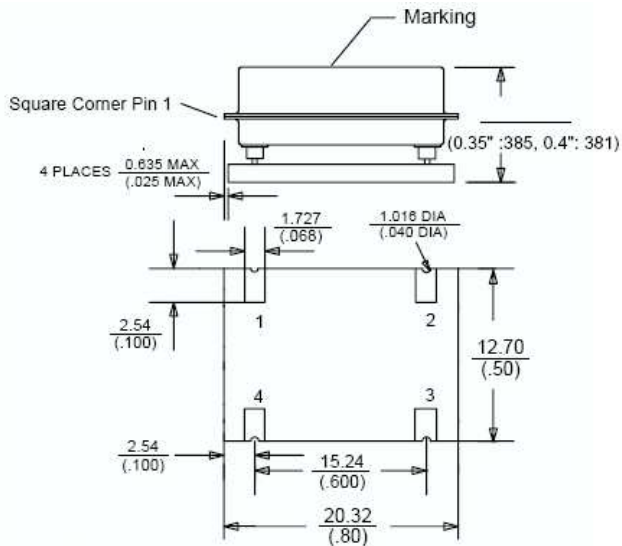

Dimensions in mm (inches)

Type B		
Code	Height "H"	Pin Length "L"
1	8.9 (0.35")	NA
2	10.2 (0.4")	NA

Pin Connections	
1	EFC \ No Connect \ Oven Monitor
7	Ground (Case)
8	RF Output
14	Supply Voltage Input

## Recommended Reflow Profile

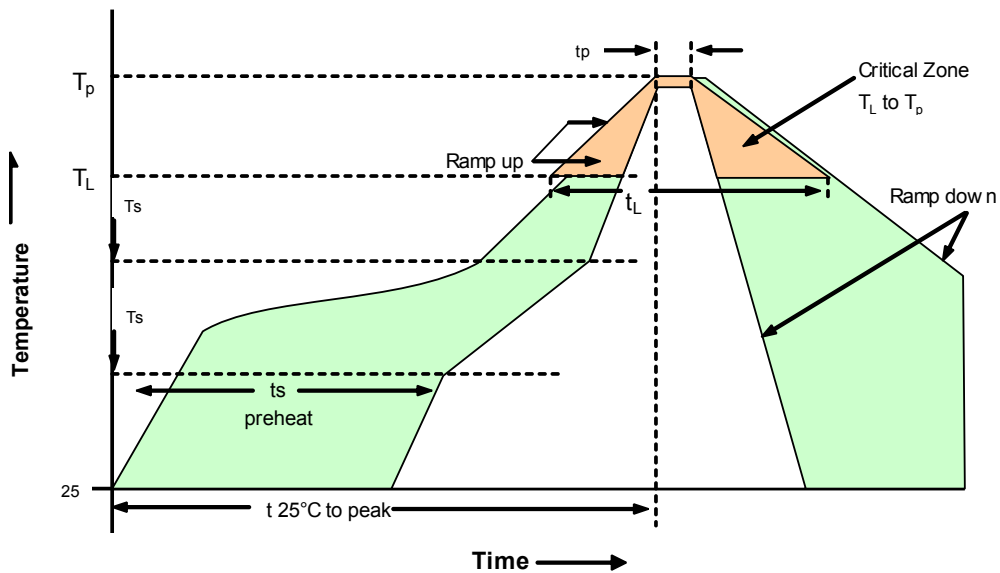

Profile Feature	Sn-Pb Assembly	Profile Feature	Sn-Pb Assembly
PRECAUTION: Series shall not expose to temperature higher than 230°C. If exposing to temperature higher than 230°C, stability and power consumption may permanently degrade.			
Average ramp-up rate (TL to Tp)	3°C/second max.	Time 25°C to Peak Temperature	4 minutes max.
Preheat - Temperature Min (T <sub>smin</sub> ) - Temperature Min (T <sub>smax</sub> ) - Time (min to max) (ts)	135°C 155°C 60-90 seconds	Time maintained above - Temperature (TL) - Time (t <sub>L</sub> )	183°C 45-60 seconds
T <sub>smax</sub> to TL - Ramp-up Rate	3°C/second max.		
Time maintained above - Temperature (TL) - Time (t <sub>L</sub> )	183°C 45-60 seconds	Time within 5°C of actual Peak Temperature (t <sub>p</sub> )	10-20 seconds max.
Peak Temperature (T <sub>p</sub> )	max 220°C	Ramp-down Rate	6°C/second max.

Note: All temperatures refer to topside of the package, measured on the package body surface.

## Ordering Information

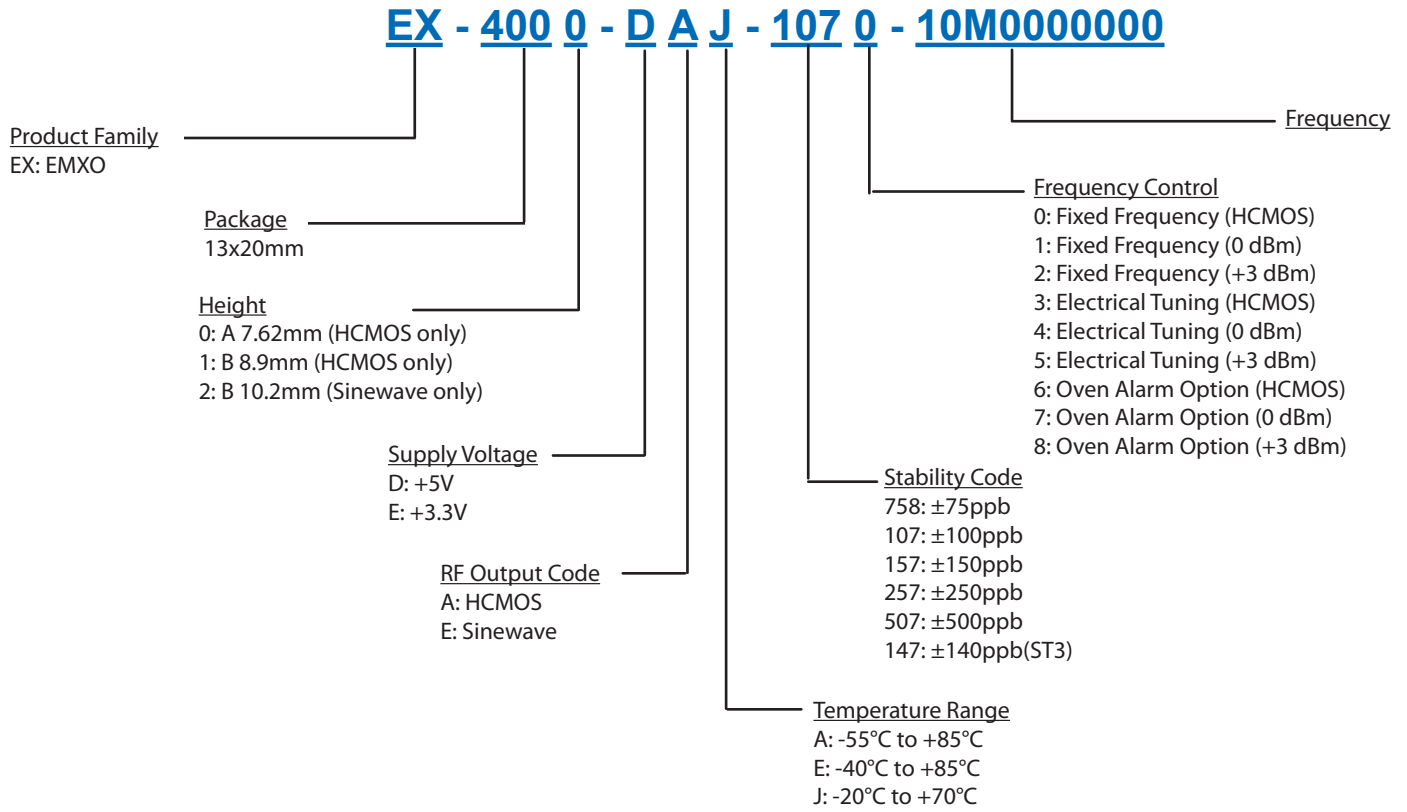

**Notes:**

1. Contact factory for improved stabilities or additional product options. Not all options and codes are available at all frequencies.
2. Unless other stated all values are valid after warm-up time and refer to typical conditions for supply voltage, frequency control voltage, load, temperature (25°C).
3. Phase noise degrades with increasing output frequency.
4. Subject to technical modification.
5. Contact factory for availability.

## For Additional Information, Please Contact

**USA:**

Vectron International  
267 Lowell Road  
Hudson, NH 03051  
Tel: 1.888.328.7661  
Fax: 1.888.329.8328

**Europe:**

Vectron International  
Landstrasse, D-74924  
Neckarbischofsheim, Germany  
Tel: +49 (0) 3328.4784.17  
Fax: +49 (0) 3328.4784.30

**Asia:**

Vectron International  
1F-2F, No 8 Workshop, No 308 Fenju Road  
WaiGaoQiao Free Trade Zone  
Pudong, Shanghai, China 200131  
Tel: 86.21.5048.0777  
Fax: 86.21.5048.1881

**Disclaimer**

Vectron International reserves the right to make changes to the product(s) and or information contained herein without notice. No liability is assumed as a result of their use or application. No rights under any patent accompany the sale of any such product(s) or information.

Rev: 1-13-2012 dmc