



Helping Customers Innovate, Improve & Grow



OX-300 / 301

Features

- Reflow Process Compatible Optional
- Surface Mount package Optional
- AT-CUT and SC_CUT Crystal Options
- Low Profile Compact Package

Applications

- Base stations
- Test equipment
- Synthesizers
- Military communication equipment
- Digital Switching

Performance Specifications

Frequency Stabilities ¹ (AT-Cut Crystal-Standard -)						
Parameter	Min	Typical	Max	Units	Condition	Options ⁵
vs. operating temperature range (referenced to +25°C)	-100		+100	ppb	-20 to +70°C	
	-200		+200	ppb	-20 to +70°C	
	-200		+200	ppb	-40 to +85°C	
Initial tolerance	-0.5		+0.5	ppm	at time of shipment, nominal EFC V _s ±5% static Load ±5% static after 30 days of operation after 30 days of operation	
vs. supply voltage change	-10		+10	ppb		
vs. load change	-10		+10	ppb		
vs. aging / day	-5		+5	ppb		
vs. aging / year	-250		+250	ppb		
Warm-up time			5	minutes	to ±100ppb of final frequency (1 hour reading) @ +25°C	
Frequency Stabilities ¹ (SC-Cut Crystal-Option - 10 to 160 MHz)						
vs. operating temperature range (referenced to +25°C)	-10		+10	ppb	-20 to +70°C	
	-20		+20	ppb	-20 to +70°C	
	-20		+20	ppb	-40 to +85°C	
Initial tolerance	-0.2		+0.2	ppm	at time of shipment, nominal EFC V _s ±5% static Load ±5% static after 30 days of operation ≤ 60 MHz; after 30 days of operation	
vs. supply voltage change	-2		+2	ppb		
vs. load change	-2		+2	ppb		
vs. aging / day	-1		+1	ppb		
vs. aging / year	-75		+75	ppb		
Warm-up time			5	minutes	to ±100ppb of final frequency (1 hour reading) @ +25°C	

Performance Specifications

Supply Voltage (Vs)						
Parameter	Min	Typical	Max	Units	Condition	
Supply voltage (standard)	3.135	3.3	3.465	VDC		
	4.75	5.0	5.25	VDC		
	11.4	12.0	12.6	VDC		
Power consumption			3.0	Watts	during warm-up	
			1.0	Watts	steady state @ +25°C	
RF Output						
Signal [standard]	HCMOS					
Load		15		pF		
Signal Level (Vol)			0.4	VDC	with Vs=3.3V and 15pF Load	
Signal Level (Vol)			0.5		with Vs=5.0V & 12V and 15pF Load	
Signal Level (Voh)	2.4			VDC	with Vs=3.3V and 15pF Load	
Signal Level (Voh)	3.5				with Vs=5.0V & 12V and 15pF Load	
Duty Cycle	45		55	%	@ (Voh-Vol)/2	
Signal	Sine Wave					
Load		50		Ω		
Output Power @3,3V	2	5	8	dBm	50 Ω load	
Putput Power @ 5.0V	5	8	11	dBm	50 Ω load	
Harmonics			-30	dBm	50 Ω load	
Frequency Tuning (EFC)						
Tuning Range	Fixed OCXO; No adjust				Option ⁵	
Tuning Range	±3.0		±8	ppm		with AT cut crystal
	±1.0		±2.5	ppm		with SC cut crystal
Linearity	10%					
Tuning Slope	Positive					
Control Voltage Range	0.0	1.4	2.8	VDC	with Vs=3.3V	
	0.0	2.0	4.0		with Vs=5.0V	
	0.0	2.0	4.0	VDC	with Vs=12.0V	
Reference Voltage Output (Vref)						
Reference Voltage	2.75	2.8	2.85	VDC	with Vs = 3.3 VDC	
	3.92	4.0	4.08	VDC	with Vs = 5.0 VDC	
	4.9	5.0	5.1	VDC	with Vs =12 VDC	
Additional Parameters						
Phase Noise ³			-90	dBc/Hz	1 Hz	@ 10MHz with SC Cut
			-120	dBc/Hz	10 Hz	
			-140	dBc/Hz	100 Hz	
			-145	dBc/Hz	1 kHz	
			-150	dBc/Hz	10 kHz	
Phase Noise ³			-75	dBc/Hz	1 Hz	@ 10MHz with AT Cut
			-105	dBc/Hz	10 Hz	
			-130	dBc/Hz	100 Hz	
			-140	dBc/Hz	1 kHz	
			-150	dBc/Hz	10 kHz	
Weight			14	g		
Processing & Packing	Handling & Processing Note					

Absolute Maximum Ratings					
supply voltage (Vs)			6.5	V	with Vs=3.3 & 5.0VDC
			15.0	V	with Vs= 12 VDC
Output Load			50	pF	
Operable Temperature Range	-55		+85	°C	
Storage Temperature Range	-55		+125	°C	

Outline Drawing / Enclosure

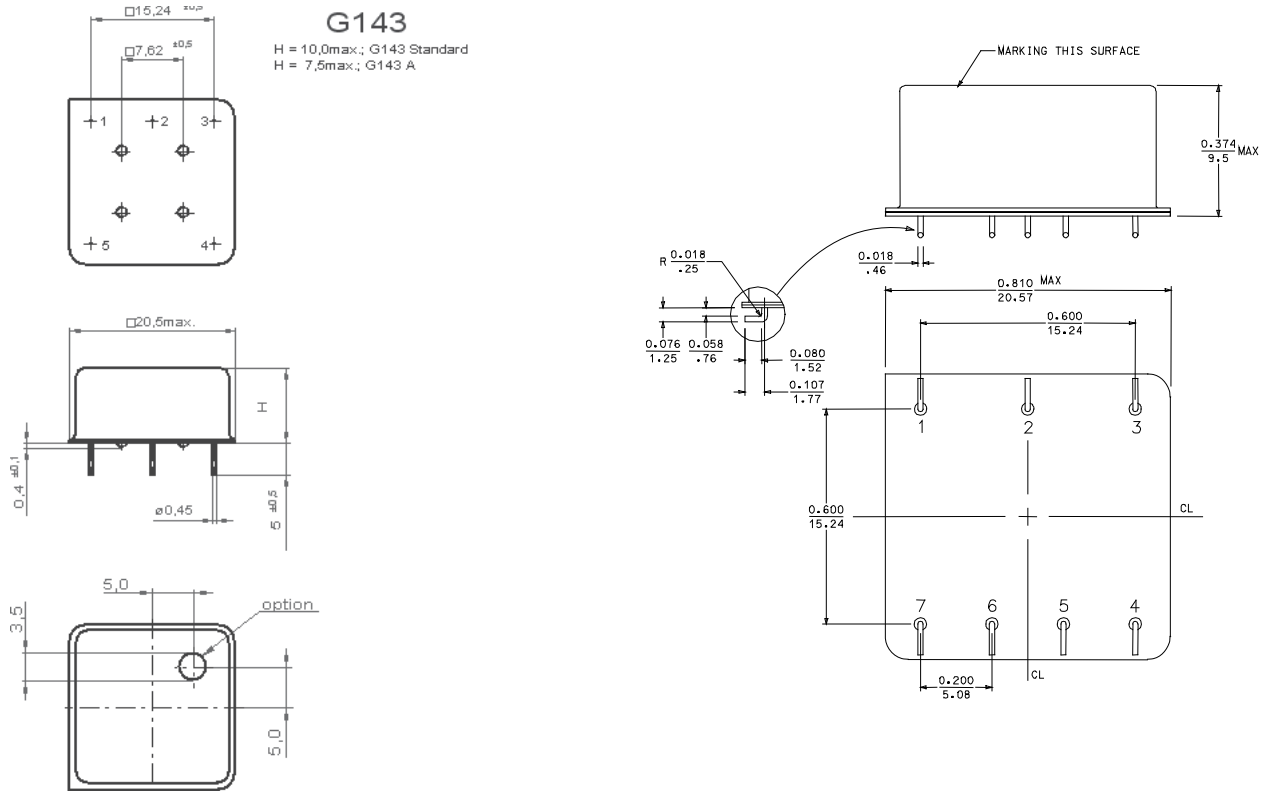

OX-300	
Height "H"	Pin Length "L"
10.0	4.5 min.

OX-301	
Height "H"	Pin Length "L"
12.7	N.A

Pin Connections	
1	Supply Voltage Input (VS)
2	RF Output
3	Ground (Case)
4	Electronic Frequency Control Input (EFC)
5	N.C or Reference Voltage Option (must remain un connected)

Pin Connections	
1	Supply Voltage Input (VS)
2	RF Output
3	Ground (Case)
4	Electronic Frequency Control Input (EFC)
5	N.C. (must remain unconnected)
6	RF Output Enable (Option)
7	Reference Voltage Output

Dimensions in mm

Standard Shipping Method (OX-301)

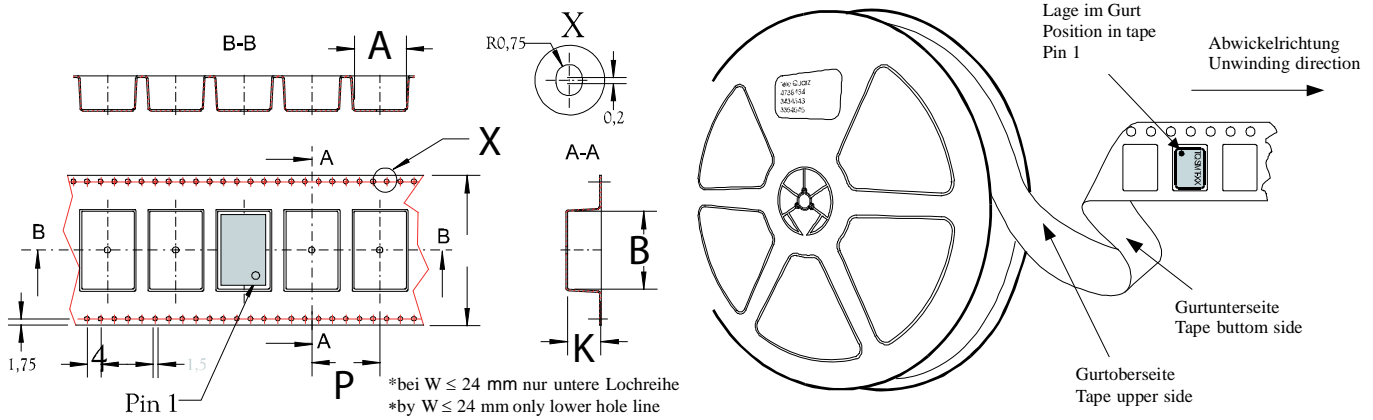

Enclosure Type	Tape Width W (mm)	Quantity per meter	Quantity per reel	Dimension P
Typ OX-301	44	37.5	280	32

Recommended Reflow Profile

Solderprofile:

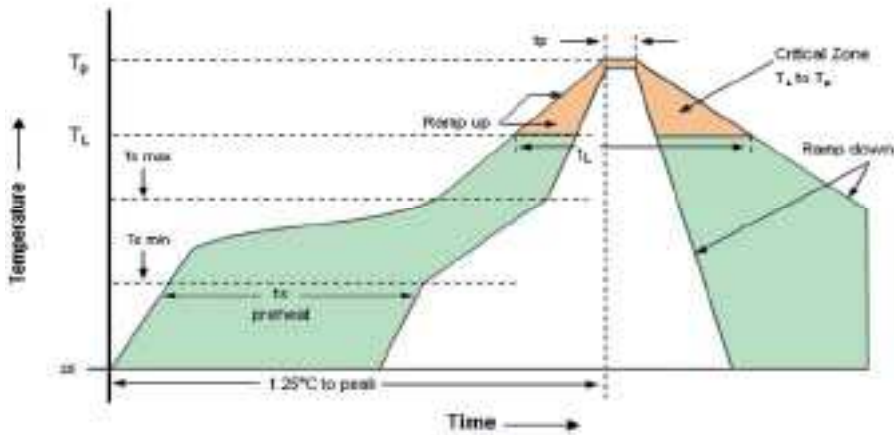

Profile Feature	Pb-Free Assembly/ Sn-Pb Assembly	Profile Feature	Pb-Free Assembly/ Sn-Pb Assembly
Average ramp-up rate (T_L to T_p)	3°C/second max.	Time 25°C to Peak Temperature	8 minutes max.
Preheat -Temperature Min T_{smin} -Temperature Min T_{smax} -Time (min to max) t_s	150°C 200°C 60-180 seconds	Time maintained above -Temperature (T_L) -Time (t_L)	217°C 60-150 seconds
T_{smax} to T_L -Ramp-up Rate	3°C/second max		
Time maintained above -Temperature (T_L) -Time (t_L)	217°C 60-150 seconds	Time within 5°C of actual Peak Temperature (t_p)	20-40 seconds
Peak Temperature (T_p)	max 260°C	Ramp-down Rate	6°C/ second max

Note: All temperatures refer to topside of the package, measured on the package body surface.

Ordering Information

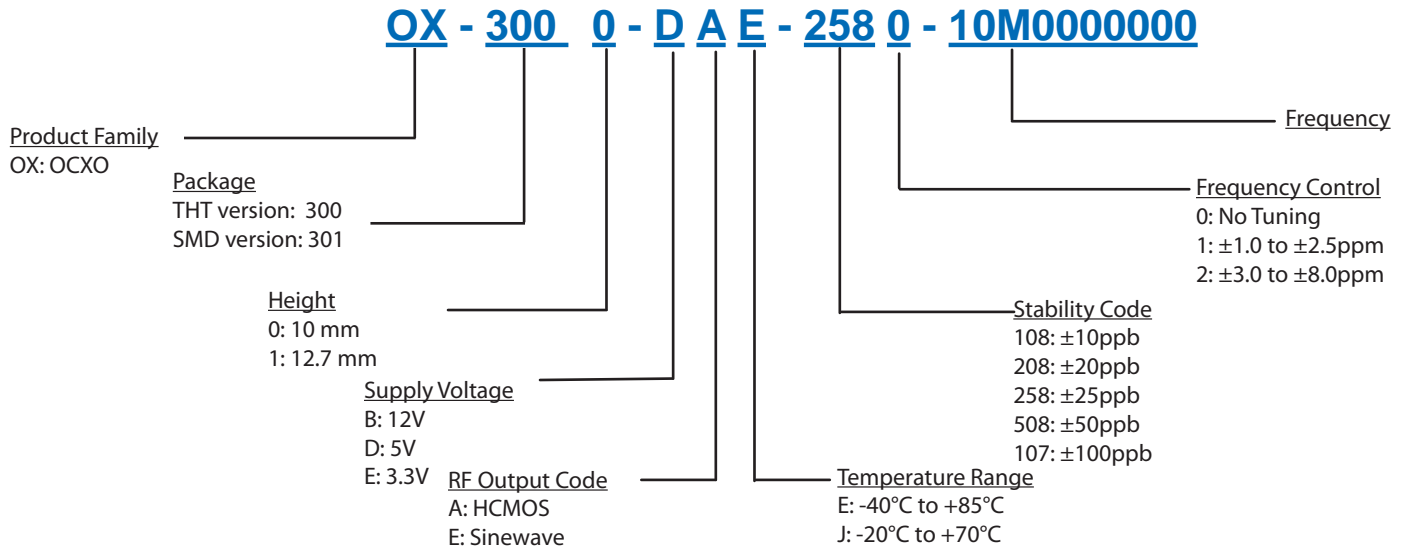

Notes:

1. Contact factory for improved stabilities or additional product options. Not all options and codes are available at all frequencies.
2. Unless other stated all values are valid after warm-up time and refer to typical conditions for supply voltage, frequency control voltage, load, temperature (25°C).
3. Phase noise degrades with increasing output frequency.
4. Subject to technical modification.
5. Contact factory for availability.

For Additional Information, Please Contact

USA:

Vectron International
267 Lowell Road
Hudson, NH 03051
Tel: 1.888.328.7661
Fax: 1.888.329.8328

Europe:

Vectron International
Landstrasse, D-74924
Neckarbischofsheim, Germany
Tel: +49 (0) 3328.4784.17
Fax: +49 (0) 3328.4784.30

Asia:

Vectron International
1F-2F, No 8 Workshop, No 308 Fenju Road
WaiGaoQiao Free Trade Zone
Pudong, Shanghai, China 200131
Tel: 86.21.5048.0777
Fax: 86.21.5048.1881

Disclaimer

Vectron International reserves the right to make changes to the product(s) and or information contained herein without notice. No liability is assumed as a result of their use or application. No rights under any patent accompany the sale of any such product(s) or information.

Rev: 8/2008