

Helping Customers Innovate, Improve & Grow



Description

The MX-170 is a high stability single oven oscillator that offers sub part per billion stability levels in a compact industry standard package. The MX-170 is the ideal foundation for high stability frequency reference solutions.

Features

- Ultra-High Stability
- Excellent Temperature Stability
- SC-Cut Crystal
- Frequency Range: 5 MHz to 15 MHz
- Low Package Height

Applications

- CDMA2000, WiMax, LTE and UMTS Base Stations
- Test and Measurement Equipment
- Broadcast Reference Standard

Performance Specifications

Parameter	Frequency Stabilities ¹				Condition
	Min	Typ	Max	Units	
vs. operating temperature range (referenced to +25°C)	-0.4		+0.4	ppb	0°C to +70°C (height code 1 only)
	-0.5		+0.5	ppb	0°C to +70°C (height code 0,1)
	-0.6		+0.6	ppb	-20°C to +70°C (height code 1 only)
	-0.7		+0.7	ppb	-20°C to +70°C (height code 0,1)
	-0.8		+0.8	ppb	-40°C to +85°C (5V supply, height code 1 only)
	-1		+1	ppb	-40°C to +85°C (5 V supply, height code 0,1)
Initial Tolerance	-50		+50	ppb	at time of shipment, nominal EFC
vs. supply voltage change	-0.5		+0.5	ppb	$V_s \pm 5\%$
vs. load change	-0.1		+0.1	ppb	Load $\pm 5\%$
vs. aging / day	-0.5		+0.5	ppb	after 72 hours of operation
vs. aging / day	-0.1		+0.1	ppb	after 7 days
vs. aging / 1 year	-20		+20	ppb	after 72 hours of operation
vs. aging / year (following years)	-10		+10	ppb	
Warm-Up time			5	minutes	to ± 10 ppb of final frequency (1 hour) @25°C

Performance Specifications

Supply					
Parameter	Min	Typ	Max	Units	Condition
Supply voltage (Standard)	4.75	5.0	5.25	VDC	
Supply voltage (Option)	11.4	12.0	12.6	VDC	
Power consumption @+5V (warm-up)			4	Watts	
Power consumption @+5V (steady state)			2	Watts	steady state @ +25°C
Power consumption @+12V (warm-up)			4	Watts	
Power consumption @+12V (steady state)			2	Watts	steady state @ +25°C
RF Output					
Signal [Option]	HCMOS				
Load		15		pF	
Signal Level (Vol)			0.5	VDC	with 15pF load
Signal Level (Voh)	3.5			VDC	with 15pF load
Duty cycle	45		55	%	(Voh-Vol)/2
Signal [Standard]	Sinewave				
Load		50		ohm	
Output Power	+5.0	+7.0	+9.0	dBm	50 Ohm load
Harmonics			-40	dBc	50 Ohm load
Sub-Harmonics			-40	dBc	50 Ohm load
Frequency Tuning (EFC)					
Tuning Range	±0.15	±0.2	±0.25	ppm	
Linearity			5	%	
Control Voltage Range	0	+2.5	+5.0	VDC	
Tuning Slope	Positive				
Additional Parameters					
Phase Noise @ 10 MHz			-95	dBc/Hz	1 Hz
			-125	dBc/Hz	10 Hz
			-140	dBc/Hz	100 Hz
			-145	dBc/Hz	1 KHz
			-145	dBc/Hz	>10 KHz
Short Term Stability			3	e-12	1 second tau
Weight			55	g	
Processing & Packing					Handling & processing note
Absolute Maximum Ratings					
Supply Voltage			15	VDC	
Output Load			50 25	pF ohm	with HCMOS signal with Sinewave signal
Operable temperature range	-55		+85	°C	
Storage temperature range	-55		+125	°C	

Outline Drawing / Enclosure

Dimensions in mm

G157

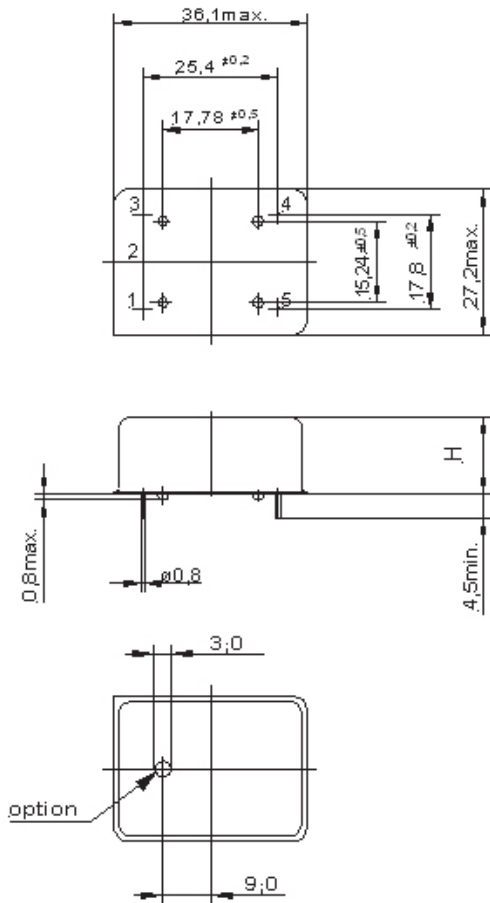

Type A

Code	Height "H"	Pin Length "L"
0	15	6.35
1	19	6.35

Pin Connections

1	Electronic Frequency Control (EFC)
2	N/C
3	RF Output
4	Ground (Case)
5	Supply Voltage Input (Vs)

Ordering Information

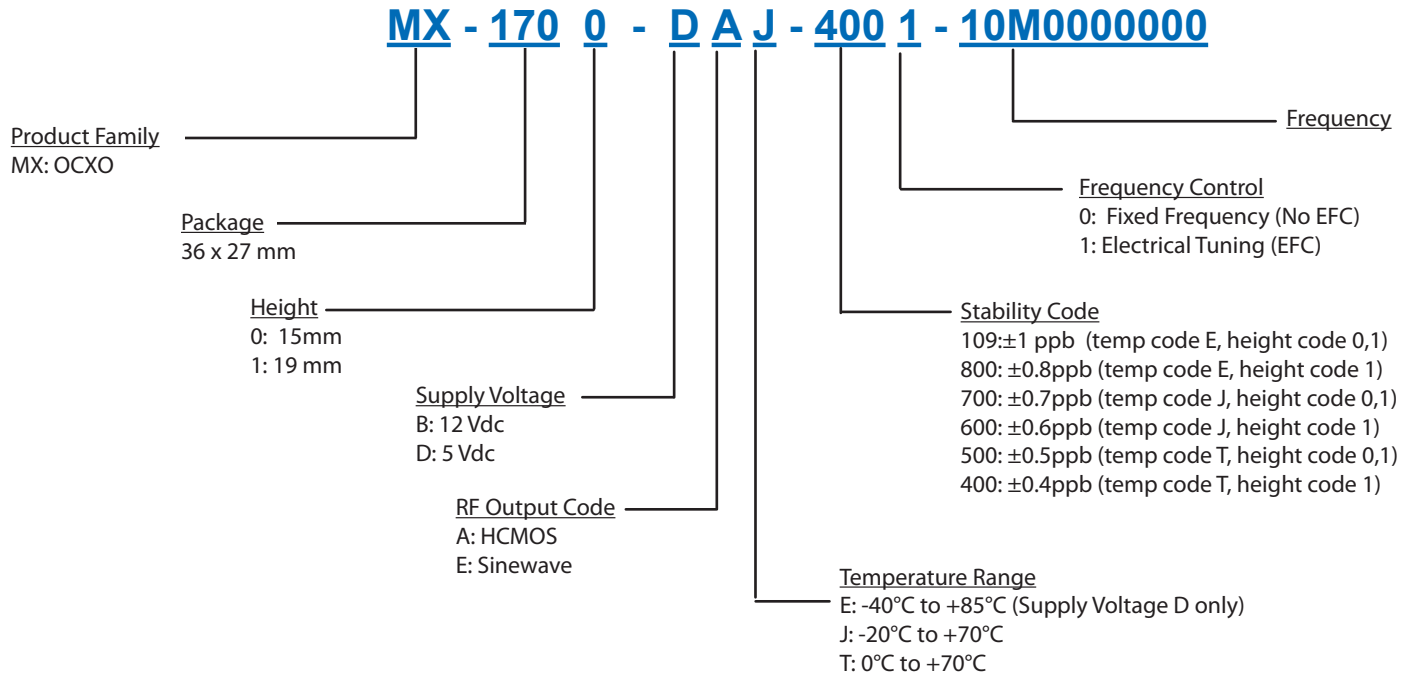

Notes:

1. Contact factory for improved stabilities or additional product options.
2. Unless other stated all values are valid after warm-up time and refer to typical conditions for supply voltage, frequency control voltage, load, temperature (25°C).
3. Phase noise degrades with increasing output frequency.
4. Subject to technical modification.
5. Contact factory for availability.

For Additional Information, Please Contact

USA:

Vectron International
267 Lowell Road
Hudson, NH 03051
Tel: 1.888.328.7661
Fax: 1.888.329.8328

Europe:

Vectron International
Landstrasse, D-74924
Neckarbischofsheim, Germany
Tel: +49 (0) 3328.4784.17
Fax: +49 (0) 3328.4784.30

Asia:

Vectron International
1F-2F, No 8 Workshop, No 308 Fenju Road
WaiGaoQiao Free Trade Zone
Pudong, Shanghai, China 200131
Tel: 86.21.5048.0777
Fax: 86.21.5048.1881

Disclaimer

Vectron International reserves the right to make changes to the product(s) and or information contained herein without notice. No liability is assumed as a result of their use or application. No rights under any patent accompany the sale of any such product(s) or information.