

Absolute encoders - bus interfaces

Redundant encoders

Magnetic single- or multiturn encoders 12 bit ST / 18 bit MT, CANopen

BMSV 58, BMMV 58 CANopen - *MAGRES* redundant



BMMV 58K CANopen with clamping flange

Features

- Encoder single- or multiturn / CANopen
- Single- and multiturn part redundant with integrated control system
- Magnetic sensing
- Resolution: singleturn 12 bit, multiturn 18 bit
- Integrated fieldbus interface
- High resistance to shock and vibrations
- Resolution and zero point programmable
- Clamping or synchro flange
- Several connector variants

Technical data - electrical ratings

Voltage supply	10...30 VDC
Consumption w/o load (typ.)	100 mA (24 VDC)
Initializing time (typ.)	170 ms after power on
Interface	CANopen
Profile conformity	CiA 301 V4.1, CiA 305 V1.0, CiA 406 V3.2 (Multi-Sensor Encoder Interface)
Steps per turn	≤4096 / 12 bit
Absolute accuracy	±1 °
Sensing method	Magnetic
Code	Binary
Code sequence	CW default, programmable
Interference immunity	DIN EN 61000-6-2
Emitted interference	DIN EN 61000-6-3
Programmable parameters	Operating modes Total resolution Scaling Rotation speed monitoring
Diagnostic functions	Position or parameter error Multiturn sensing
Approval	UL approval / E217823
BMMV 58K, BMMV 58S	
Function	Multiturn
Number of turns	≤262144 / 18 bit
BMSV 58K, BMSV 58S	
Function	Singleturn

Technical data - mechanical design

Dimensions (flange)	ø58 mm
Protection DIN EN 60529	IP 65
Operating speed	≤12000 rpm (mechanical) ≤6000 rpm (electric)
Operating torque typ.	0.023 Nm
Materials	Housing: aluminium Flange: aluminium
Operating temperature	-20...+65 °C
Relative humidity	95 %
Resistance	DIN EN 60068-2-6 Vibration 30 g, 10-2000 Hz DIN EN 60068-2-27 Shock 500 g, 6 ms
Weight approx.	300 g
Connection	Connector M12 Cable
BMMV 58K, BMSV 58K	
Shaft	ø10 mm (clamping flange)
Flange	Clamping flange
Shaft loading	≤40 N axial ≤60 N radial
BMMV 58S, BMSV 58S	
Shaft	ø6 mm (synchro flange)
Flange	Synchro flange
Shaft loading	≤10 N axial ≤20 N radial

Absolute encoders - bus interfaces

Redundant encoders

Magnetic single- or multiturn encoders 12 bit ST / 18 bit MT, CANopen

BMSV 58, BMMV 58 CANopen - *MAGRES* redundant

CANopen features	
Bus protocol	CANopen
Device profile	CANopen - CiA DSP 406, V 3.0 (Multi-Sensor Encoder Interface Device Class 2, CAN 2.0B)
Operating modes	- Event-triggered / Time-triggered - Remotely-requested - Sync (cyclic) / Sync (acyclic)
Preset	Parameter for setting the encoder to a requested position value assigned to a defined shaft position of the system. The offset of encoder zero point and mechanical zero point is stored in the encoder.
Rotating direction	Parameter for defining the rotating direction in which there have to be ascending or descending position values. Default setting: Ascending position values when looking at the flange and rotating the shaft clockwise.
Scaling	Parameter defining the steps per turn as well as the total resolution.
Diagnosis	The encoder supports the following error warnings: - Position error redundancy system - Position and parameter error - Lithium battery voltage (multiturn)
Node Monitoring	Heartbeat or Nodeguarding
Default	50 kbit/s, Node ID 1

Accessories	
Connectors and cables	
10153968	Female connector M12, 5-pin, A-coded, straight
10137485	Female connector M12, 5-pin, A-coded, straight, shielded, 5 m
10153969	Cable connector M12, CAN, 5-pin, straight
10156842	Cable with male/female M12, 5-pin, angled, A-coded, 5 m
10161399	Cable with male/female M12, 5-pin, shielded, straight, A-coded, 5 m
Mounting accessories for BMMV 58K, BMSV 58K	
10252773	Clamp set \varnothing 15 mm
11053277	Bellows coupling aluminium/stainless steel 10 mm
Mounting accessories for BMMV 58S, BMSV 58S	
10252773	Clamp set \varnothing 15 mm
Programming accessories	
10147362	CD-ROM with GSD-/EDS-/XML files and user manuals

Absolute encoders - bus interfaces

Redundant encoders

Magnetic single- or multiturn encoders 12 bit ST / 18 bit MT, CANopen

BMSV 58, BMMV 58 CANopen - MAGRES redundant

Terminal significance

+Vs	Encoder supply voltage.
0 V	Encoder ground connection relating to +Vs.
CAN_L	CAN bus signal (dominant Low).
CAN_H	CAN bus signal (dominant High).
CAN_GND	GND relating to CAN interface.

Terminal assignment

Cable

for connection reference **-5**

Core colour	Signals	Description
blue	d.u.	do not use
yellow	CAN_L	Bus (dominant LOW)
grey	CAN_GND	CAN Ground
red	d.u.	do not use
pink	n.c.	–
white	0 V	Supply voltage
green	CAN_H	Bus (dominant HIGH)
–	n.c.	–
brown	+Vs	Supply voltage
Screen	connected to housing	
Cable data	8 x 0.14 mm ²	

Connector (2 x M12) male/female

for connection reference **-M**

Conn.	Signals	Description
Pin 1	CAN_GND	CAN Ground
Pin 2	+Vs	Supply voltage
Pin 3	0 V	Supply voltage
Pin 4	CAN_H	Bus (dominant HIGH)
Pin 5	CAN_L	Bus (dominant LOW)

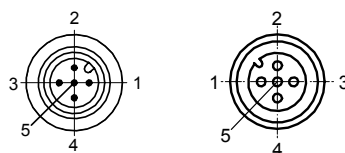

Connector M12 male

for connection reference **-N**

Conn.	Signals	Description
Pin 1	CAN_GND	CAN Ground
Pin 2	+Vs	Supply voltage
Pin 3	0 V	Supply voltage
Pin 4	CAN_H	Bus (dominant HIGH)
Pin 5	CAN_L	Bus (dominant LOW)

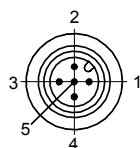

Absolute encoders - bus interfaces

Redundant encoders

Magnetic single- or multiturn encoders 12 bit ST / 18 bit MT, CANopen

BMSV 58, BMMV 58 CANopen - MAGRES redundant

Dimensions

BMSV/BMMV 58 CANopen clamping flange, cable radial

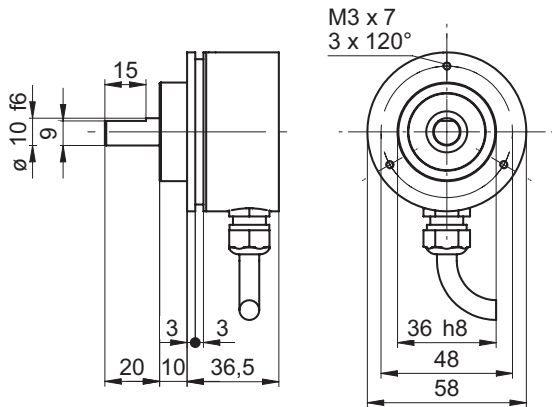

BMSV/BMMV 58 CANopen clamping flange, 2 x M12

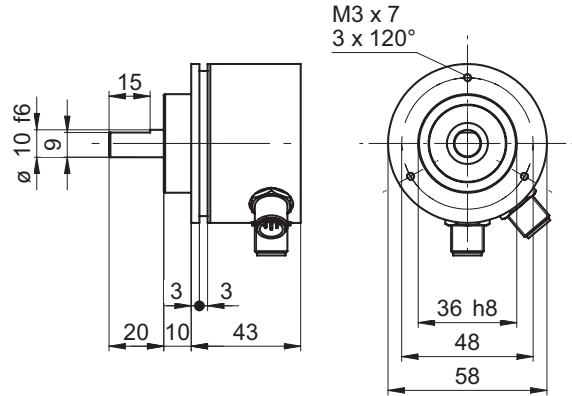

BMSV/BMMV 58 CANopen clamping flange, 1 x M12

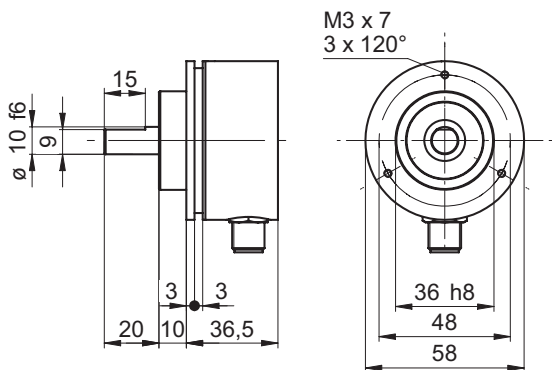

BMSV/BMMV 58 CANopen synchro flange, cable radial

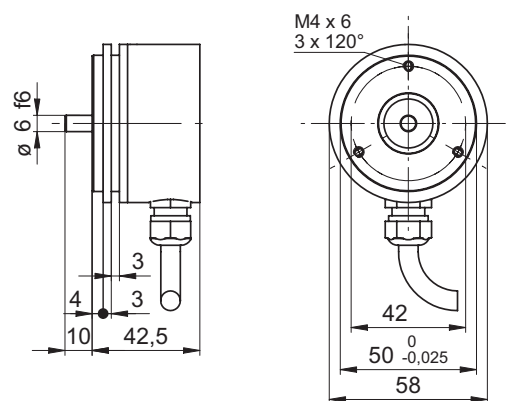

BMSV/BMMV 58 CANopen synchro flange, 2 x M12

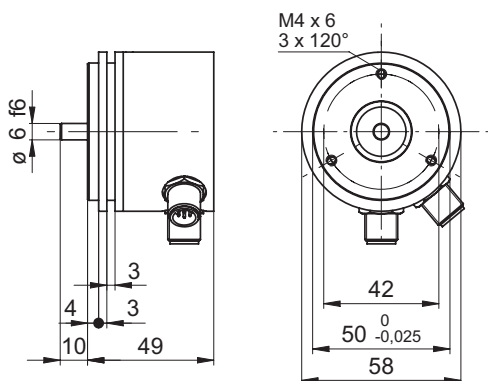

BMSV/BMMV 58 CANopen synchro flange, 1 x M12

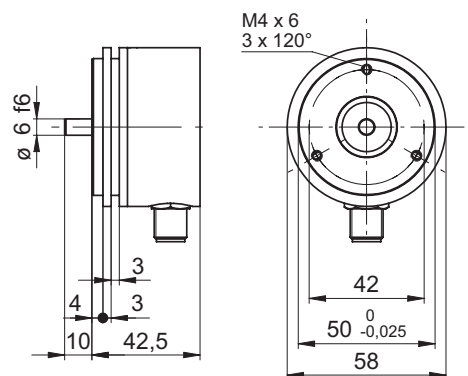

Absolute encoders - bus interfaces

Redundant encoders

Magnetic single- or multiturn encoders 12 bit ST / 18 bit MT, CANopen

BMSV 58, BMMV 58 CANopen - *MAGRES* redundant
