

## General Description

The AAT351x PowerManager products are members of AnalogicTech's Total Power Management IC™ (TPMIC™) product family. This family of microprocessor reset circuits provides the ultimate in versatility, allowing system designers full customization of the  $\mu$ P monitor and reset function without any additional components. The AAT351x family offers several combinations of threshold voltage, watchdog timeout period, reset active period, and output drive configurations, which are all factory-programmed options. All devices are available in 32 reset threshold voltages from 2.6V up to 5V, with three watchdog timeout periods from 6.3ms to 1600ms and three reset timeouts from 1ms up to 140ms. Available output configurations are active low push-pull, active low open drain, active low bi-directional, and active high push-pull.

The AAT351x family is designed to ignore fast negative transients on  $V_{DD}$  and to ensure that reset outputs remain valid down to 1V.

The AAT351x family is available in the Pb-free, space-saving 5-pin SOT23 surface mount package and is specified over the -40 to +85°C temperature range.

## Features

- Tight Voltage Tolerance:  $\pm 1.5\%$
- Low Quiescent Current: 5 $\mu$ A
- Guaranteed Reset Valid Down to 1V
- 32 Voltage Options from 2.6V to 5.0V
- Three Reset Active Period Options:
  - 1ms, 20ms, 140ms
- Three Watchdog Timeout Period Options:
  - 6.3ms, 102ms, 1600ms
- Four Output Options:
  - Open Drain
  - Inverting
  - Non-Inverting
  - Bi-Directional
- Low Temperature Coefficient: 100ppm/°C
- 5-Pin SOT23 Package

## Applications

- Critical  $\mu$ P and  $\mu$ C Supply Monitoring
- Embedded Control Systems
- Industrial Controllers
- Intelligent Instruments
- Notebook Computers
- Portable Electronics
- Power-On Reset Circuits

## Typical Application

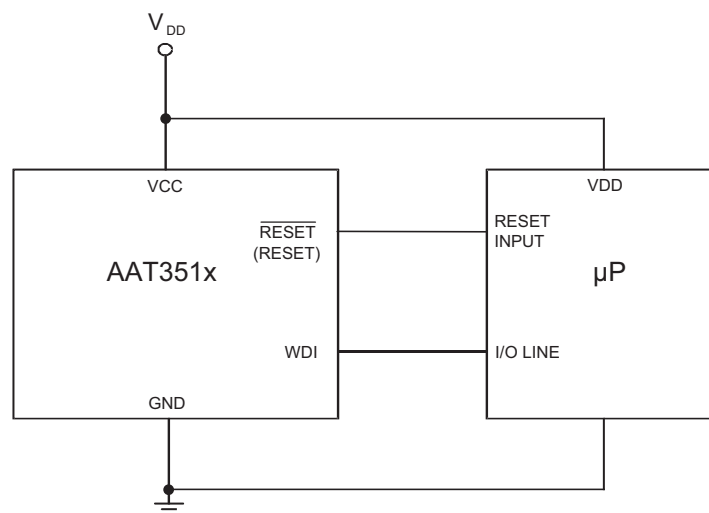

## Pin Descriptions

Pin Number				Symbol	Function
AAT3510 AAT3517	AAT3512	AAT3515	AAT3518		
1	N/A	1	1	$\overline{\text{RESET}}$	AAT3510/15: $\overline{\text{RESET}}$ output goes low whenever $V_{DD}$ falls below the reset threshold. CMOS push-pull output. AAT3517: $\overline{\text{RESET}}$ output goes low whenever $V_{DD}$ falls below the reset threshold. Open drain output. Connect a pull-up resistor to any supply voltage up to 5.5V. AAT3518: $\overline{\text{RESET}}$ output goes low whenever $V_{DD}$ falls below the reset threshold. Open drain output. Connect a pull-up resistor to any supply voltage up to 5.5V.
2	2	2	2	GND	Ground connection pin.
N/A	1	3	3	RESET	RESET active-high output. This CMOS push-pull signal is the logical inverse of $\overline{\text{RESET}}$ .
3	3	4	N/A	$\overline{\text{MR}}$	Manual reset input pin. Active low. Pull low to force a reset.
4	4	N/A	4	WDI	Watchdog input pin. Triggers a reset if it remains in a steady state for the duration of the watchdog timer period.
5	5	5	5	VCC	Input voltage pin.

## Pin Configuration

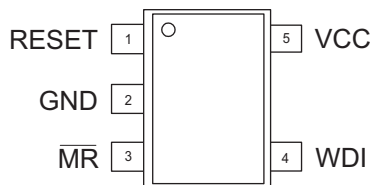
**5-lead SOT23  
(Top View)**

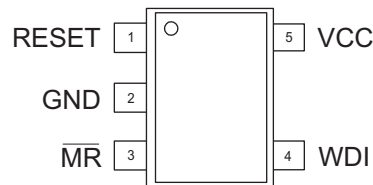
 AAT3510  
AAT3517

**5-lead SOT23  
(Top View)**

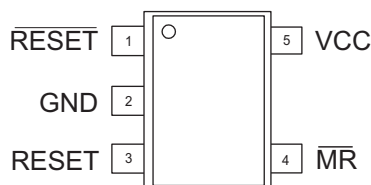
AAT3512

**5-lead SOT23  
(Top View)**

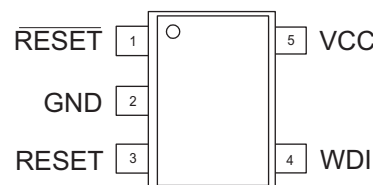
AAT3515

**5-lead SOT23  
(Top View)**

AAT3518

## Absolute Maximum Ratings<sup>1</sup>

$T_A = 25^\circ\text{C}$ , unless otherwise noted.

Symbol	Description	Max	Units
$V_{CC}$	$V_{CC}$ to GND	-0.3 to 6	V
$V_{MR}, V_{WDI}$	$\overline{MR}, \overline{WDI}$ to GND	-0.3 to $V_{CC} + 0.3$	V
$V_{RESET}$	$\overline{RESET}$ to GND (Push-Pull or Bidirectional Output)	-0.3 to $V_{CC} + 0.3$	V
	$\overline{RESET}$ to GND (Open Drain Output)	-0.3 to 6	
$I_{VCC}, I_{MR}, I_{WDI}$	Maximum Continuous Input Current	20	mA
$I_{RESET}$	$\overline{RESET}/\overline{RESET}$ Output Current	20	mA
$dV_{CC}/dt$	Rate of Rise of $V_{CC}$	100	V/ $\mu$ s
$T_J$	Operating Junction Temperature Range (-40°C to +150°C)	150	°C

## Thermal Information<sup>2</sup>

Symbol	Description	Value	Units
$\Theta_{JA}$	Maximum Thermal Resistance	190	°C/W
$P_D$	Maximum Power Dissipation	526	mW

1. Stresses above those listed in Absolute Maximum Ratings may cause permanent damage to the device. Functional operation at conditions other than the operating conditions specified is not implied. Only one Absolute Maximum Rating should be applied at any one time.

2. Mounted on an FR4 board.

## Electrical Characteristics

$V_{CC} = 2.5V$  to  $5.5V$ ,  $T_A = -40^\circ C$  to  $+85^\circ C^1$ , unless otherwise noted. Typical values are at  $T_A = 25^\circ C$ .

Symbol	Description	Conditions	Min	Typ	Max	Units
$V_{CC}$	Operating Voltage Range	$T_A = -40^\circ C$ to $+85^\circ C$	1		5.5	V
$I_{CC}$	Supply Current	AAT3510/2/7/8: MR & WDI Unconnected	$V_{CC} = 3.6V$	5	15	$\mu A$
			$V_{CC} = 5.5V$	6	18	
		AAT3515: MR Unconnected	$V_{CC} = 3.6V$		15	
			$V_{CC} = 5.5V$		18	
$V_{TH}$	Reset Threshold Voltage	$T_A = 25^\circ C$	$V_{THNOM} - 1.5\%$	$V_{TH}$	$V_{THNOM} + 1.5\%$	V
		$T_A = -40$ to $+85^\circ C$	$V_{THNOM} - 2.5\%$	$V_{TH}$	$V_{THNOM} + 2.5\%$	
$T_C$	Reference Voltage Temperature Coefficient	$-40^\circ C < T_A < +85^\circ C$		$\pm 40$		ppm/ $^\circ C$
$t_{RP}$	Reset Active Timeout Period	AAT351xIGV-xx-A-x-T1	1	1.4	2	ms
		AAT351xIGV-xx-B-x-T1	20	28	40	
		AAT351xIGV-xx-C-x-T1	140	200	280	
$T_{RD}$	$V_{CC}$ to RESET Delay	$V_{CC}$ Falling at $1mV/\mu s$		40		$\mu s$
<b>Push/ Pull RESET Output (AAT3510, 3512, 3515, 3518)</b>						
$V_{OL}$	RESET Low Output Voltage	$V_{CC} \geq 1.0V, I_{SINK} = 50\mu A$			0.3	V
		$V_{CC} \geq 1.2V, I_{SINK} = 100\mu A$			0.3	
		$V_{CC} \geq 2.7V, I_{SINK} = 1.2mA$			0.3	
		$V_{CC} \geq 4.5V, I_{SINK} = 3.2mA$			0.4	
$V_{OH}$	RESET High Output Voltage	$V_{CC} \geq 2.7V, I_{SOURCE} = 500\mu A$	$0.8 \times V_{CC}$			V
		$V_{CC} \geq 4.5V, I_{SOURCE} = 800\mu A$	$V_{CC} - 1.5$			
$V_{OH}$	RESET Low Output Voltage	$V_{CC} \geq 2.7V, I_{SINK} = 1.2mA$			0.3	V
		$V_{CC} \geq 4.5V, I_{SINK} = 3.2mA$			0.4	
	RESET High Output Voltage	$V_{CC} \geq 1.8V, I_{SOURCE} = 150\mu A$	$0.8 \times V_{CC}$			
		$V_{CC} \geq 2.7V, I_{SOURCE} = 500\mu A$	$0.8 \times V_{CC}$			
		$V_{CC} \geq 4.5V, I_{SOURCE} = 800\mu A$	$V_{CC} - 1.5$			

1. Over-temperature limits are guaranteed by design, not production tested.

## Electrical Characteristics

$V_{CC} = 2.5V$  to  $5.5V$ ,  $T_A = -40^\circ C$  to  $+85^\circ C$ <sup>1</sup>, unless otherwise noted. Typical values are at  $T_A = 25^\circ C$ .

Symbol	Description	Conditions	Min	Typ	Max	Units
<b>Open-Drain RESET Output (AAT3517, 3518)</b>						
$V_{OL}$	RESET Low Output Voltage	$V_{CC} \geq 1.0V, I_{SINK} = 50\mu A$			0.3	V
		$V_{CC} \geq 1.2V, I_{SINK} = 100\mu A$			0.3	
		$V_{CC} \geq 2.7V, I_{SINK} = 1.2mA$			0.3	
		$V_{CC} \geq 4.5V, I_{SINK} = 3.2mA$			0.4	
$I_{D(OFF)}$	Reset Leakage Current				1.0	$\mu A$
<b>Watchdog Input (AAT3510, 3512, 3517, 3518)</b>						
$t_{WD}$	Watchdog Timeout Period	AAT351xIGV-xx-x-A-T1	4.3	6.3	9.3	ms
		AAT351xIGV-xx-x-B-T1	71	102	153	
		AAT351xIGV-xx-x-C-T1 <sup>2</sup>	1.12	1.6	2.4	s
$t_{WDI}$	WDI Minimum Pulse Width	$V_{IL} = 0.3 \times V_{CC}, V_{IH} = 0.7 \times V_{CC}$		50		ns
$V_{IL}$	WDI Input Threshold <sup>3</sup>		$0.3 \times V_{CC}$			
$V_{IH}$	WDI Input Threshold <sup>3</sup>				$0.8 \times V_{CC}$	V
$I_{WDI}$	WDI Input Current <sup>4</sup>	WDI = $V_{CC}$ , Time Average		120	160	$\mu A$
		$V_{WDI} = 0$ , Time Average	-20	-15		
<b>Manual RESET Input (3515)</b>						
$V_{IL}$	MR Input Threshold		$0.3 \times V_{CC}$			
$V_{IH}$	MR Input Threshold				$0.7 \times V_{CC}$	V
	MR Input Pulse Width		1			$\mu s$
	MR Glitch Rejection			100		ns
	MR Internal Pull-Up Resistance	$T_A = 25^\circ C$	35	52	75	$k\Omega$
	MR to Reset Delay	$V_{CC} = 5V$			230	ns

1. Over-temperature limits are guaranteed by design, not production tested.

2. Watchdog timeout period C is not available on AAT3518.

3. WDI is internally serviced within the watchdog period if WDI is left unconnected.

4. The WDI input current is specified as the average input current when the WDI input is driven high or low. The WDI input is designed for a three-stated-output device with a  $10\mu A$  maximum leakage current and capable of driving a maximum capacitive load of 200pF. The three-state device must be able to source and sink at least  $200\mu A$  when active.

## Typical Characteristics

Unless otherwise noted,  $V_{IN} = 3V$ ,  $T_A = 25^\circ C$ .

Supply Current vs. Temperature

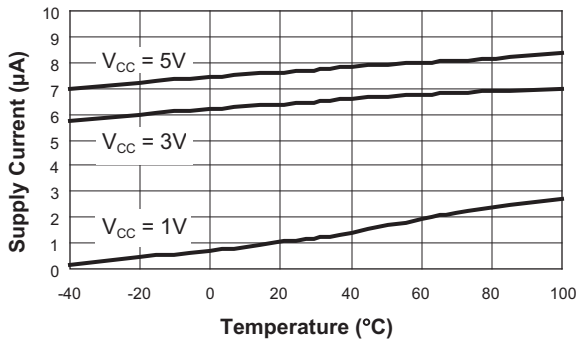

V<sub>CC</sub> Falling to RESET Propagation Delay vs. Temperature

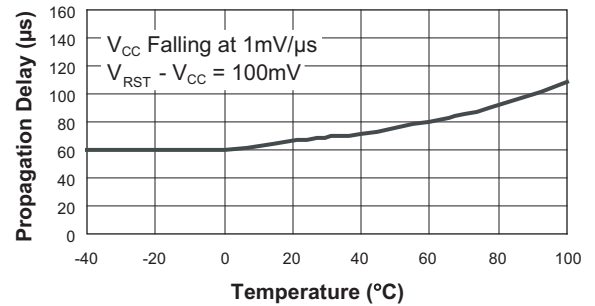

Manual Reset to RESET Propagation Delay vs. Temperature

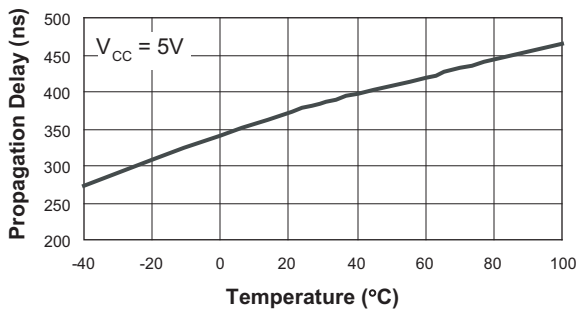

Normalized Reset Timeout Period vs. Temperature

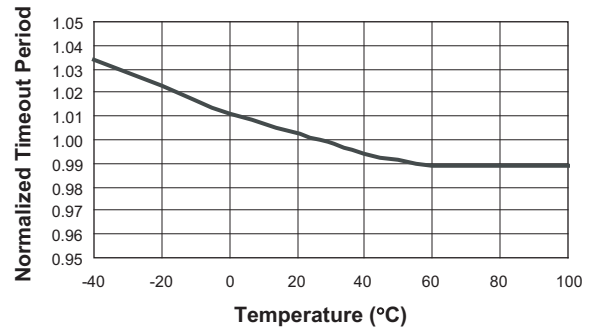

Normalized Watchdog Timeout Period vs. Temperature

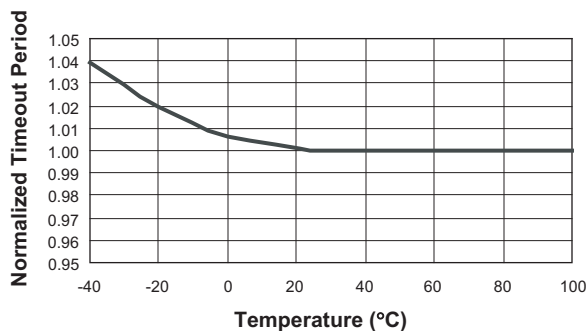

Maximum V<sub>CC</sub> Transient Duration vs. Reset Threshold Overdrive

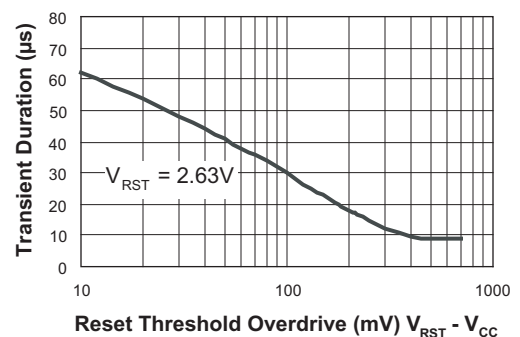

## Typical Characteristics

Unless otherwise noted,  $V_{IN} = 3V$ ,  $T_A = 25^\circ C$ .

### Bidirectional Pullup Characteristic

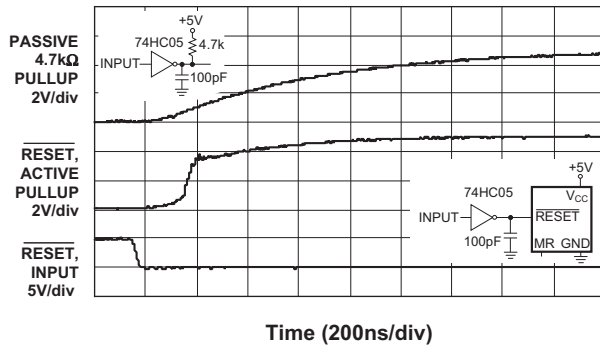

**Functional Block Diagram**

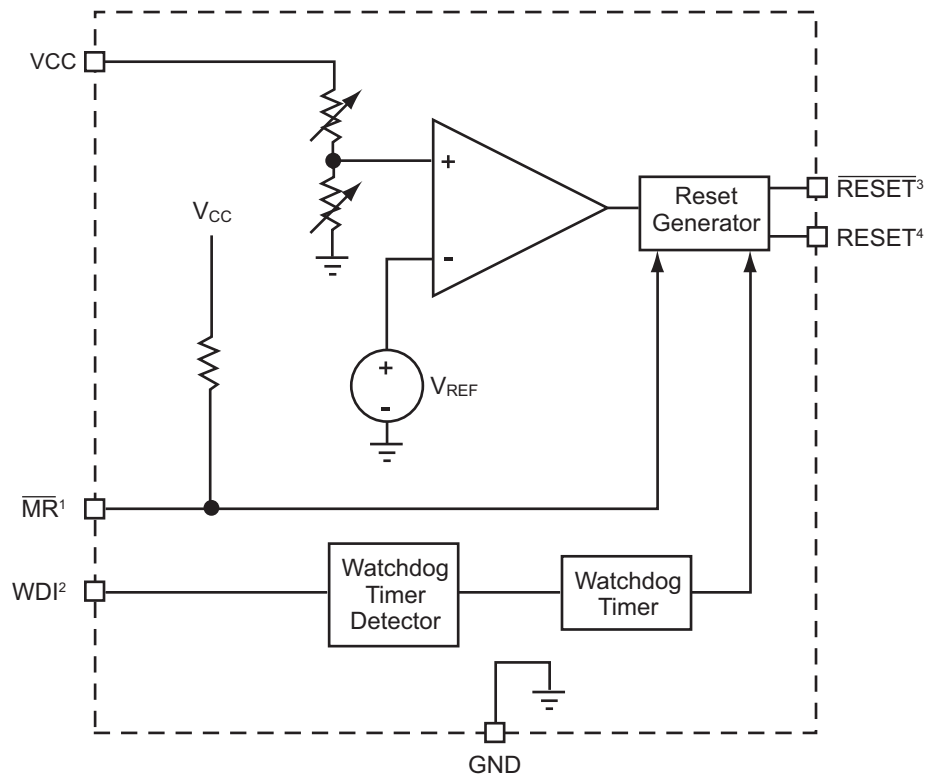

1. MR pin available on AAT3510/2/5/7.  
 2. WDI pin available on AAT3510/2/7/8.  
 3. RESET pin available on AAT3510/5/7/8.  
 4. RESET pin available on AAT3512/5/8.

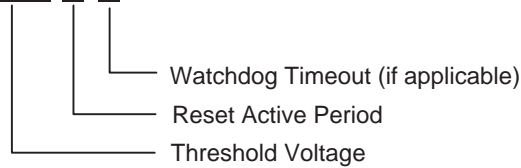
**Factory-Trimmed Reset Thresholds<sup>1</sup> and Ordering Information**
**AAT351x IGV-X.XX-X-X-T1**

**Reset Active Period**

- A:  $T_{R(MIN)} = 1\text{ms}$   
 B:  $T_{R(MIN)} = 20\text{ms}$   
 C:  $T_{R(MIN)} = 140\text{ms}$

**Watchdog Timeout Period**

- A:  $T_{WD(NOM)} = 6.3\text{ms}$   
 B:  $T_{WD(NOM)} = 102\text{ms}$   
 C:  $T_{WD(NOM)} = 1600\text{ms}$ <sup>1</sup>

**VDD Threshold Voltage**

2.63: $V_{TH(NOM)} = 2.63\text{V}$	3.90: $V_{TH(NOM)} = 3.9\text{V}$
2.70: $V_{TH(NOM)} = 2.7\text{V}$	4.00: $V_{TH(NOM)} = 4.0\text{V}$
2.80: $V_{TH(NOM)} = 2.8\text{V}$	4.10: $V_{TH(NOM)} = 4.1\text{V}$
2.93: $V_{TH(NOM)} = 2.93\text{V}$	4.20: $V_{TH(NOM)} = 4.2\text{V}$
3.00: $V_{TH(NOM)} = 3.0\text{V}$	4.38: $V_{TH(NOM)} = 4.3\text{V}$
3.08: $V_{TH(NOM)} = 3.08\text{V}$	4.40: $V_{TH(NOM)} = 4.38\text{V}$
3.20: $V_{TH(NOM)} = 3.2\text{V}$	4.50: $V_{TH(NOM)} = 4.5\text{V}$
3.30: $V_{TH(NOM)} = 3.3\text{V}$	4.63: $V_{TH(NOM)} = 4.63\text{V}$
3.40: $V_{TH(NOM)} = 3.4\text{V}$	4.70: $V_{TH(NOM)} = 4.7\text{V}$
3.50: $V_{TH(NOM)} = 3.5\text{V}$	4.80: $V_{TH(NOM)} = 4.8\text{V}$
3.60: $V_{TH(NOM)} = 3.6\text{V}$	4.90: $V_{TH(NOM)} = 4.9\text{V}$
3.70: $V_{TH(NOM)} = 3.7\text{V}$	5.00: $V_{TH(NOM)} = 5.0\text{V}$
3.80: $V_{TH(NOM)} = 3.8\text{V}$	

1. Watchdog timeout period C is not available on AAT3518.

**Ordering Information**

Package	Marking <sup>1</sup>	Part Number (Tape and Reel) <sup>2</sup>
SOT23-5	HVXY	AAT3510I GV-2.63-C-C-T1
SOT23-5	HUXY	AAT3510I GV-2.93-C-C-T1
SOT23-5	HGY	AAT3510I GV-3.08-C-C-T1
SOT23-5	HHXY	AAT3510I GV-4.38-C-C-T1
SOT23-5	EWXY	AAT3511I GV-2.63-C-C-T1
SOT23-5	MYXY	AAT3512I GV-2.63-A-C-T1
SOT23-5	HEXY	AAT3515I GV-2.63-C-T1
SOT23-5	HIXY	AAT3515I GV-2.93-B-T1
SOT23-5	KLXY	AAT3515I GV-2.93-C-T1
SOT23-5	JNXY	AAT3515I GV-3.08-C-T1
SOT23-5	KMXY	AAT3515I GV-4.38-C-T1
SOT23-5	MFXY	AAT3515I GV-4.63-C-T1
SOT23-5	INXY	AAT3517I GV-2.63-C-C-T1
SOT23-5	LZXY	AAT3517I GV-2.8-B-C-T1
SOT23-5	IQXY	AAT3517I GV-2.93-C-C-T1
SOT23-5	P9XY	AAT3518I GV-3.00-B-B-T1



All AnalogicTech products are offered in Pb-free packaging. The term “Pb-free” means semiconductor products that are in compliance with current RoHS standards, including the requirement that lead not exceed 0.1% by weight in homogeneous materials. For more information, please visit our website at <http://www.analogictech.com/aboutus/quality.php>.

1. XYY = date and assembly code.

2. Sample stock is generally held on part numbers listed in **BOLD**.

**Package Information**

**SOT23-5**

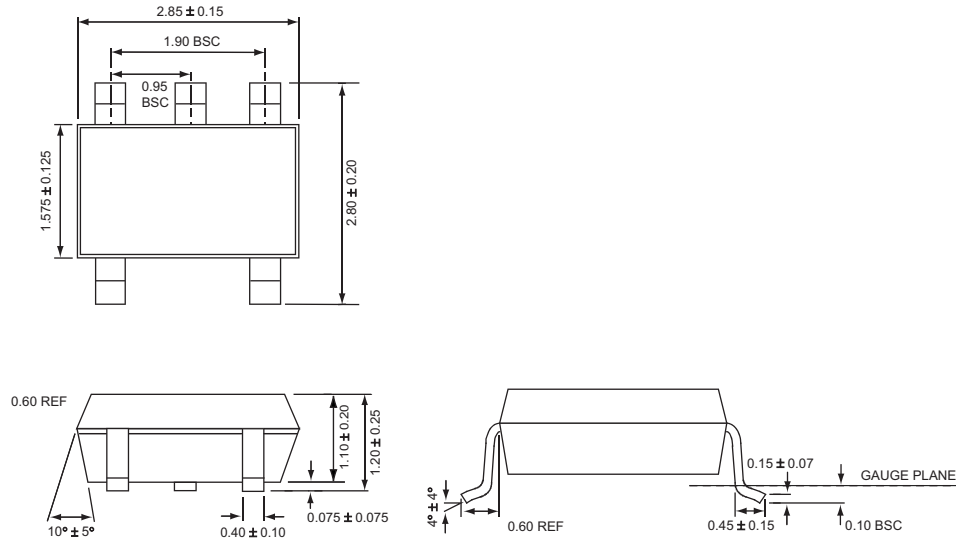

All dimensions in millimeters.

## Revision History

Date	Revision	Edits
8/30/2010	3510.2010.09.1.9	1. Remove obsolete products: AAT3511, AAT3513, AAT3514, AAT3516, AAT3519. 2. add new part number AAT3518IGV-3.00-B-B-T1.

**Advanced Analogic Technologies, Inc.**  
3230 Scott Boulevard, Santa Clara, CA 95054  
Phone (408) 737-4600  
Fax (408) 737-4611



© Advanced Analogic Technologies, Inc.  
AnalogicTech cannot assume responsibility for use of any circuitry other than circuitry entirely embodied in an AnalogicTech product. No circuit patent licenses, copyrights, mask work rights, or other intellectual property rights are implied. AnalogicTech reserves the right to make changes to their products or specifications or to discontinue any product or service without notice. Except as provided in AnalogicTech's terms and conditions of sale, AnalogicTech assumes no liability whatsoever, and AnalogicTech disclaims any express or implied warranty relating to the sale and/or use of AnalogicTech products including liability or warranties relating to fitness for a particular purpose, merchantability, or infringement of any patent, copyright or other intellectual property right. In order to minimize risks associated with the customer's applications, adequate design and operating safeguards must be provided by the customer to minimize inherent or procedural hazards. Testing and other quality control techniques are utilized to the extent AnalogicTech deems necessary to support this warranty. Specific testing of all parameters of each device is not necessarily performed. AnalogicTech and the AnalogicTech logo are trademarks of Advanced Analogic Technologies Incorporated. All other brand and product names appearing in this document are registered trademarks or trademarks of their respective holders.