

# Absolute encoders - bus interfaces

## Encoder with cable-pull

### Magnetic multiturn encoders 12 bit ST / 18 bit MT, CANopen

#### BMMS M75 CANopen / cable-pull - MAGRES



BMMS M75 CANopen with connector M12

#### Features

- Encoder with cable-pull / CANopen
- Magnetic sensing
- Resolution: 0.1 mm/step
- Integrated fieldbus interface
- Integrated control system (differential control)
- Measuring length max. 7500 mm

#### Technical data - electrical ratings

Voltage supply	10...30 VDC
Consumption w/o load (typ.)	50 mA (24 VDC)
Interface	CANopen
Function	Multiturn
Profile conformity	CANopen CiA DSP 301 4.01, DSP 305 V1.0, DSP 406 V3.0
Resolution	0.1 mm/step
Linearity	±0.07 % des Messbereichs
Number of steps	75000 (7500 mm)
Sensing method	Magnetic
Code	Binary
Code sequence	Programmable
Interference immunity	DIN EN 61000-6-2
Emitted interference	DIN EN 61000-6-3
Programmable parameters	Operating modes Total resolution Scaling Rotation speed monitoring
Diagnostic functions	Position or parameter error Multiturn sensing

#### Technical data - mechanical design

Protection DIN EN 60529	IP 65 (connector model), IP 67 (cable model)
Materials	Encoder housing: aluminium Cable-pull: PA6 GF30 Cable: Stainless steel cable sheathed with polyamide
Operating temperature	-40...+85 °C
Service life	Type 500 000 strokes
Length	7500 mm
Distance/revolution	333.32 ±0,3 mm
Cable acceleration	≤15 m/s <sup>2</sup>
Relative humidity	95 %
Resistance	DIN EN 60068-2-6 Vibration 10 g, 10-2000 Hz DIN EN 60068-2-27 Shock 50 g, 11 ms
Weight approx.	900 g
Connection	Connector M12, 5-pin Cable

# Absolute encoders - bus interfaces

Encoder with cable-pull

Magnetic multiturn encoders 12 bit ST / 18 bit MT, CANopen

## BMMS M75 CANopen / cable-pull - MAGRES

### Part number

BMMS M755N 24B 12/18 00

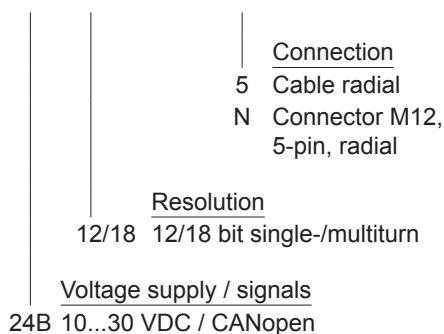

### Accessories

#### Connectors and cables

10153968	Female connector M12, 5-pin, A-coded, straight
10137485	Female connector M12, 5-pin, A-coded, straight, shielded, 5 m
10153972	T-junction M12 CAN (1 male/2 female)
10153974	Terminating resistor CAN
10156842	Cable with male/female M12, 5-pin, angled, A-coded, 5 m
10161399	Cable with male/female M12, 5-pin, shielded, straight, A-coded, 5 m

#### Programming accessories

10147362	CD-ROM with GSD-/EDS-/XML files and user manuals
----------	--

# Absolute encoders - bus interfaces

## Encoder with cable-pull

### Magnetic multiturn encoders 12 bit ST / 18 bit MT, CANopen

#### BMMS M75 CANopen / cable-pull - MAGRES

##### Terminal significance

+Vs	Encoder supply voltage.
0 V	Encoder ground connection relating to +Vs.
CAN_L	CAN bus signal (dominant Low).
CAN_H	CAN bus signal (dominant High).
CAN_GND	GND relating to CAN interface.
Drain	Housing.

##### CANopen features

Bus protocol	CANopen ISO / DIS 11898
Device profile	CANopen - CiA DSP 406, V 3.0 (Device Class 2, CAN 2.0B)
Operating modes	- Event-triggered / Time-triggered - Remotely-requested - Sync (cyclic) / Sync (acyclic)
Preset	Parameter for setting the encoder to a requested position value assigned to a defined position of the system. The offset of encoder zero point and mechanical zero point is stored in the encoder.
Rotating direction	Parameter for defining the rotating direction in which there have to be ascending or descending position values.
Scaling	Parameter defining the steps.
Diagnosis	The encoder supports the following error warnings: - Position error redundancy system - Position and parameter error - Lithium battery voltage (multi-turn)
Node Monitoring	Heartbeat or Nodeguarding
Default	50 kbit/s, Node ID 1

##### Terminal assignment

Cable for connection reference -5		
Core colour	Signals	Description
blue	d.u.	do not use
yellow	CAN_L	Bus (dominant LOW)
grey	CAN_GND	CAN Ground
red	d.u.	do not use
pink	n.c.	-
white	0 V	Supply voltage
green	CAN_H	Bus (dominant HIGH)
-	n.c.	-
brown	+Vs	Supply voltage
Screen	connected to housing	
Cable data	8 x 0.14 mm <sup>2</sup>	

##### Connector M12 male for connection reference -N

Conn.	Signals	Description
Pin 1	n.c.	Not connected
Pin 2	+Vs	Supply voltage
Pin 3	CAN_GND	CAN Ground
Pin 4	CAN_H	Bus (dominant HIGH)
Pin 5	CAN_L	Bus (dominant LOW)

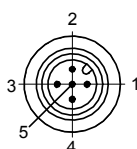

# Absolute encoders - bus interfaces

Encoder with cable-pull

Magnetic multiturn encoders 12 bit ST / 18 bit MT, CANopen

## BMMS M75 CANopen / cable-pull - MAGRES

### Dimensions

#### BMMS M75 with connector M12

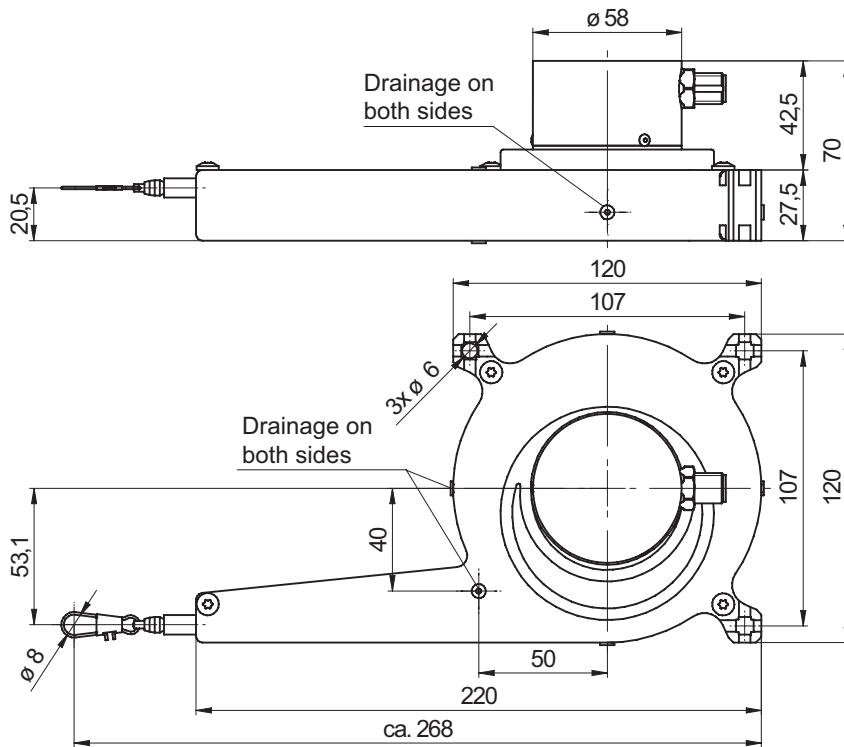

#### BMMS M75 with cable radial

