

Absolute encoders - SSI

Encoder with cable-pull

Magnetic multiturn encoders 12 bit ST / 13 bit MT

BMMS K50 SSI / cable-pull - MAGRES



BMMS K50 SSI with connector M12

Features

- Encoder with cable-pull / SSI
- Encoder multiturn
- Magnetic sensing
- Resolution: 0.1 mm/step
- Measuring length max. 5000 mm

Technical data - electrical ratings

Voltage supply	10...30 VDC
Consumption w/o load (typ.)	50 mA (24 VDC)
Initializing time	≤170 ms after power on
Interface	SSI
Function	Multiturn
Resolution	0.1 mm/step
Linearity	±0.5 % des Messbereichs
Number of steps	50000 (5000 mm)
Sensing method	Magnetic
Code	Gray or binary
Inputs	SSI clock Reset input
Interference immunity	DIN EN 61000-6-2
Emitted interference	DIN EN 61000-6-3

Technical data - mechanical design

Protection DIN EN 60529	IP 67
Materials	Encoder housing: aluminium Cable-pull: PA6 GF30 Cable: Stainless steel cable sheathed with polyamide
Operating temperature	-40...+85 °C
Service life	Type >500000 strokes
Length	5000 mm
Distance/revolution	239.7 ±0,6 mm
Relative humidity	95 %
Resistance	DIN EN 60068-2-6 Vibration 10 g, 10-2000 Hz DIN EN 60068-2-27 Shock 50 g, 11 ms
Weight approx.	600 g
Connection	Cable

Absolute encoders - SSI

Encoder with cable-pull

Magnetic multiturn encoders 12 bit ST / 13 bit MT

BMMS K50 SSI / cable-pull - MAGRES

Part number

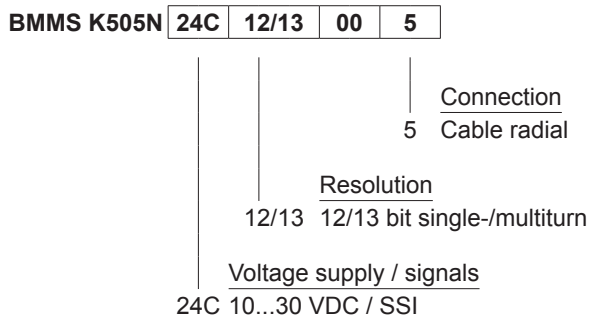

Data transfer

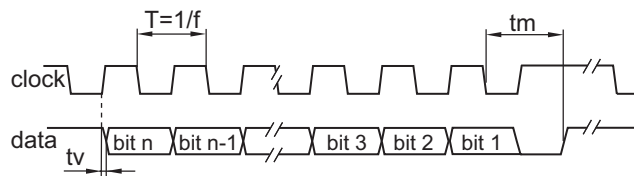

Absolute encoders - SSI

Encoder with cable-pull

Magnetic multiturn encoders 12 bit ST / 13 bit MT

BMMS K50 SSI / cable-pull - MAGRES

Terminal significance	
+Vs	Encoder supply voltage.
0 V	Encoder ground connection relating to +Vs.
Data+	Positive, serial data output of differential linedriver.
Data-	Negative, serial data output of differential linedriver.
Clock+	Positive SSI clock input. Clock+ together with Clock- forms a current loop. A current of approx. 7 mA towards Clock+ input means logic 1 in positive logic.
Clock-	Negative SSI clock input. Clock- together with Clock+ forms a current loop. A current of approx. 7 mA towards Clock- input means logic 0 in positive logic.
Zero	Input for setting a zero point anywhere within the encoder resolution. The zero setting operation is triggered by a Low impulse. Connect to +Vs after setting operation for maximum interference immunity. Impulse duration >2 ms.
Rot. direction	Ascending position values when looking at the flange and rotating the shaft clockwise.

Terminal assignment			
Cable for connection references -5			
Connector	Core colour	Signals	Description
Pin 1	yellow	Clock-	Clock signal
Pin 2	green	Clock+	Clock signal
Pin 3	grey	Data+	Data signal
Pin 4	pink	Data-	Data signal
Pin 5	blue	Zero	Zero setting input
Pin 6	–	n.c.	–
Pin 7	–	n.c.	–
Pin 8	–	n.c.	–
Pin 9	red	d.u.	do not use
Pin 10	–	n.c.	–
Pin 11	brown	+Vs	Supply voltage
Pin 12	white	0 V	Supply voltage
Screen	connected to housing		
Cable data	8 x 0.14 mm ²		

Trigger level	
Control inputs	Input circuit
Input level Low	<0,4 V (>2 ms)
Input level High	+Vs or open

Absolute encoders - SSI

Encoder with cable-pull

Magnetic multiturn encoders 12 bit ST / 13 bit MT

BMMS K50 SSI / cable-pull - MAGRES

Dimensions

BMMS K50 cable radial

