

# Absolute encoders - SSI

Magnetic sensor bore max.  $\varnothing 6$  mm

Magnetic single- or multiturn encoders / kit 12 bit ST / 13 bit MT

## BMSK 42, BMMK 42 SSI - MAGRES



BMMK 42 SSI kit

### Features

- Mini encoder / kit single- or multiturn / SSI
- Magnetic sensing
- Resolution: singleturn 12 bit, multiturn 13 bit
- Housing  $\varnothing 42$  mm
- High resistance to shock and vibrations
- Reset input

### Technical data - electrical ratings

Voltage supply	5 VDC $\pm 10$ % 10...30 VDC
Consumption w/o load (typ.)	100 mA (5 VDC) 50 mA (24 VDC)
Initializing time (typ.)	170 ms after power on
Interface	SSI
Steps per turn	4096 / 12 bit
Absolute accuracy	$\pm 1^\circ$
Sensing method	Magnetic
Code	Gray or binary
Code sequence	CW: ascending values with clockwise sense of rotation (looking at flange)
Inputs	SSI clock Reset input
Output circuit	SSI data: linedriver RS485
Interference immunity	DIN EN 61000-6-2
Emitted interference	DIN EN 61000-6-3
Approval	UL approval / E217823
<b>BMSK 42</b>	
Function	Singleturn
<b>BMMK 42</b>	
Function	Multiturn
Number of turns	8192 / 13 bit

### Technical data - mechanical design

Dimensions (flange)	$\varnothing 55$ mm
Shaft	Magnet hole 6 mm
Protection DIN EN 60529	IP 67
Operating speed	$\leq 12000$ rpm (mechanical) $\leq 6000$ rpm (electric)
Operating temperature	$-20 \dots +85$ °C
Relative humidity	95 %
Resistance	DIN EN 60068-2-6 Vibration 30 g, 10-2000 Hz DIN EN 60068-2-27 Shock 100 g, 6 ms
Connection	Connector M12, 8-pin Cable
Gap tolerance	$\leq 0.3$ mm axial $\leq 0.1$ mm radial

### BMSK 42

Materials	Housing: steel/aluminium Flange: aluminium
Weight approx.	50 g

### BMMK 42

Materials	Housing: steel Flange: aluminium
Weight approx.	300 g

# Absolute encoders - SSI

Magnetic sensor bore max.  $\varnothing 6$  mm

Magnetic single- or multiturn encoders / kit 12 bit ST / 13 bit MT

## BMSK 42, BMMK 42 SSI - MAGRES

### Part number

#### Singleturn

BMSK 42L1		05C	12/00	06	
					Connection
					5 Cable radial
					N Connector M12, radial
					Shaft
				06	Magnet hole $\varnothing 6$ mm
					Resolution
			12/00		12 bit singleturn
					Voltage supply / signals
		05C			5 VDC / SSI
					Code
	G				Gray code
	N				Binary code

#### Multiturn

BMMK 42L1			12/13	06	
					Connection
					5 Cable radial
					N Connector M12, radial
					Shaft
				06	Magnet hole $\varnothing 6$ mm
					Resolution
			12/13		12/13 bit single-/multiturn
					Voltage supply / signals
		05C			5 VDC / SSI
		24C			10...30 VDC / SSI
					Code
	G				Gray code
	N				Binary code

### Data transfer

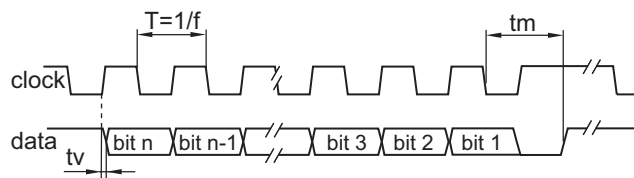

Clock frequency f	100...1000 kHz
Scan ratio of T	40...60 %
Time lag tv	200 ns
Monoflop time tm	20 $\mu$ s + T/2

### Accessories

#### Connectors and cables

10146775	Female connector M12, 8-pin, straight
10127844	Female connector M12, 8-pin, straight, shielded, 2 m
10129332	Female connector M12, 8-pin, straight, shielded, 5 m cable

#### Mounting accessories

10112433	Hexagon wrench 2 mm
----------	---------------------

# Absolute encoders - SSI

Magnetic sensor bore max.  $\varnothing 6$  mm

Magnetic single- or multiturn encoders / kit 12 bit ST / 13 bit MT

## BMSK 42, BMMK 42 SSI - MAGRES

### Terminal significance

+Vs	Encoder supply voltage.
0 V	Encoder ground connection relating to +Vs.
Data+	Positive, serial data output of differential linedriver.
Data-	Negative, serial data output of differential linedriver.
Clock+	Positive SSI clock input. Clock+ together with Clock- forms a current loop. A current of approx. 7 mA towards Clock+ input means logic 1 in positive logic.
Clock-	Negative SSI clock input. Clock- together with Clock+ forms a current loop. A current of approx. 7 mA towards Clock- input means logic 0 in positive logic.
Zero	Input for setting a zero point anywhere within the encoder resolution. The zero setting operation is triggered by a Low impulse. Connect to +Vs after setting operation for maximum interference immunity. Impulse duration >2 ms.
Rot. direction	Ascending position values when looking at the flange and rotating the shaft clockwise.

### Terminal assignment

#### Cable

for connection reference **-5**

Core colour	Signals	Description
brown	+Vs	Supply voltage
white	0 V	Supply voltage
grey	Data+	Data signal
pink	Data-	Data signal
green	Clock+	Clock signal
yellow	Clock-	Clock signal
blue	Zero	Zero setting input
red	d.u.	do not use
Screen	connected to housing	
Cable data	8 x 0.14 mm <sup>2</sup>	

#### Connector M12 male

for connection reference **-N**

Connector	Signals	Description
Pin 1	0 V	Supply voltage
Pin 2	+Vs	Supply voltage
Pin 3	Clock+	Clock signal
Pin 4	Clock-	Clock signal
Pin 5	Data+	Data signal
Pin 6	Data-	Data signal
Pin 7	Zero	Zero setting input
Pin 8	d.u.	do not use

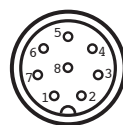

### Trigger level

Control inputs	Input circuit
Input level Low	<0,4 V (>2 ms)
Input level High	+Vs or open

# Absolute encoders - SSI

Magnetic sensor bore max.  $\varnothing 6$  mm

Magnetic single- or multiturn encoders / kit 12 bit ST / 13 bit MT

## BMSK 42, BMMK 42 SSI - MAGRES

### Dimensions

BMSK 42 SSI cable radial

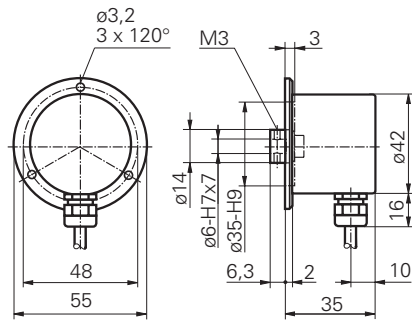

BMSK 42 SSI connector axial

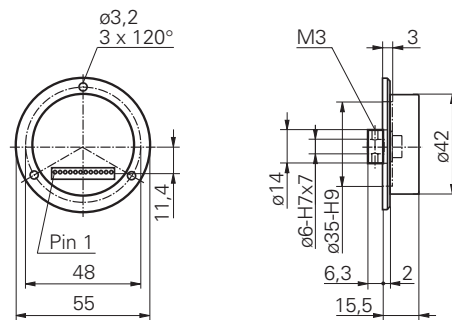

BMSK 42 SSI connector M12 radial

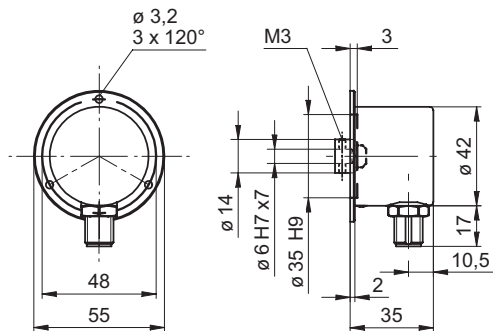

BMMK 42 SSI cable radial

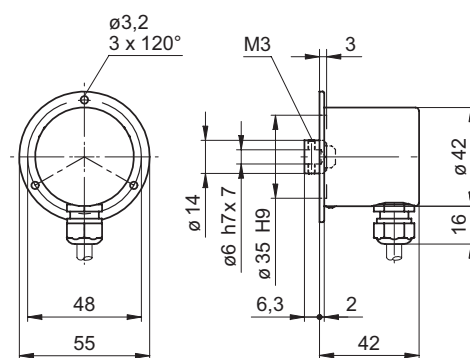

BMMK 42 SSI connector M12 radial

