

Absolute encoders - bus interfaces

End shaft $\varnothing 12$ mm

Magnetic single- or multiturn encoders 12 bit ST / 18 bit MT, CANopen

BMSH 58, BMMH 58 CANopen - MAGRES



BMMH 58 CANopen with end shaft

Features

- Encoder single- or multiturn / CANopen
- Magnetic sensing
- Resolution: singleturn 12 bit, multiturn 18 bit
- Integrated fieldbus interface
- High resistance to shock and vibrations
- Resolution and zero point programmable

Technical data - electrical ratings

Voltage supply	10...30 VDC
Consumption w/o load (typ.)	100 mA (24 VDC)
Initializing time (typ.)	170 ms after power on
Interface	CANopen
Profile conformity	CANopen CiA DSP 301 4.01, DSP 305 V1.0, DSP 406 V3.0
Steps per turn	≤ 4096 / 12 bit
Absolute accuracy	$\pm 1^\circ$
Sensing method	Magnetic
Code	Binary
Code sequence	CW default, programmable
Interference immunity	DIN EN 61000-6-2
Emitted interference	DIN EN 61000-6-3
Programmable parameters	Operating modes Total resolution Scaling Rotation speed monitoring
Diagnostic functions	Position or parameter error Multiturn sensing
Approval	UL approval / E217823
BMSH 58	
Function	Singleturn
BMMH 58	
Function	Multiturn
Number of turns	≤ 262144 / 18 bit

Technical data - mechanical design

Dimensions (flange)	$\varnothing 58$ mm
Shaft	$\varnothing 12$ mm end shaft
Protection DIN EN 60529	IP 65
Operating speed	≤ 12000 rpm (mechanical) ≤ 6000 rpm (electric)
Operating torque typ.	0.0093 Nm
Materials	Housing: aluminium Flange: aluminium
Operating temperature	-20...+85 °C
Relative humidity	95 %
Resistance	DIN EN 60068-2-6 Vibration 30 g, 10-2000 Hz DIN EN 60068-2-27 Shock 500 g, 6 ms
Weight approx.	300 g
Connection	Connector M12 Connector D-SUB, 9-pin Cable

Absolute encoders - bus interfaces

End shaft $\varnothing 12$ mm

Magnetic single- or multiturn encoders 12 bit ST / 18 bit MT, CANopen

BMSH 58, BMMH 58 CANopen - MAGRES

Terminal significance

+Vs	Encoder supply voltage.
0 V	Encoder ground connection relating to +Vs.
CAN_L	CAN bus signal (dominant Low).
CAN_H	CAN bus signal (dominant High).
CAN_GND	GND relating to CAN interface.

CANopen features

Bus protocol	CANopen
Device profile	CANopen - CiA DSP 406, V 3.0 (Device Class 2, CAN 2.0B)
Operating modes	- Event-triggered / Time-triggered - Remotely-requested - Sync (cyclic) / Sync (acyclic)
Preset	Parameter for setting the encoder to a requested position value assigned to a defined shaft position of the system. The offset of encoder zero point and mechanical zero point is stored in the encoder.
Rotating direction	Parameter for defining the rotating direction in which there have to be ascending or descending position values. Default setting: Ascending position values when looking at the flange and rotating the shaft clockwise.
Scaling	Parameter defining the steps per turn as well as the total resolution.
Diagnosis	The encoder supports the following error warnings: - Position and parameter error - Lithium battery voltage (multi-turn)
Node Monitoring	Heartbeat or Nodeguarding
Default	50 kbit/s, Node ID 1

Terminal assignment

Cable / connector D-Sub male
for connection reference **-F** and **-5**

Conn.	Core colour	Signals	Description
Pin 1	blue	d.u.	do not use
Pin 2	yellow	CAN_L	Bus (dominant LOW)
Pin 3	grey	CAN_GND	CAN Ground
Pin 4	red	d.u.	do not use
Pin 5	pink	n.c.	-
Pin 6	white	0 V	Supply voltage
Pin 7	green	CAN_H	Bus (dominant HIGH)
Pin 8	-	n.c.	-
Pin 9	brown	+Vs	Supply voltage
Screen	connected to housing		
Cable data	8 x 0.14 mm ²		

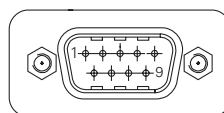

Connector (2 x M12) male/female
for connection reference **-M**

Conn.	Signals	Description
Pin 1	n.c.	-
Pin 2	+Vs	Supply voltage
Pin 3	CAN_GND	CAN Ground
Pin 4	CAN_H	Bus (dominant HIGH)
Pin 5	CAN_L	Bus (dominant LOW)

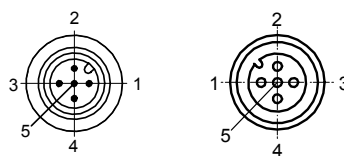

Connector M12 male
for connection reference **-N**

Conn.	Signals	Description
Pin 1	n.c.	-
Pin 2	+Vs	Supply voltage
Pin 3	CAN_GND	CAN Ground
Pin 4	CAN_H	Bus (dominant HIGH)
Pin 5	CAN_L	Bus (dominant LOW)

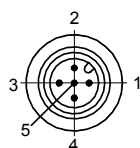

Absolute encoders - bus interfaces

End shaft $\varnothing 12$ mm

Magnetic single- or multiturn encoders 12 bit ST / 18 bit MT, CANopen

BMSH 58, BMMH 58 CANopen - MAGRES

Dimensions

BMSH/BMMH 58 CANopen cable radial

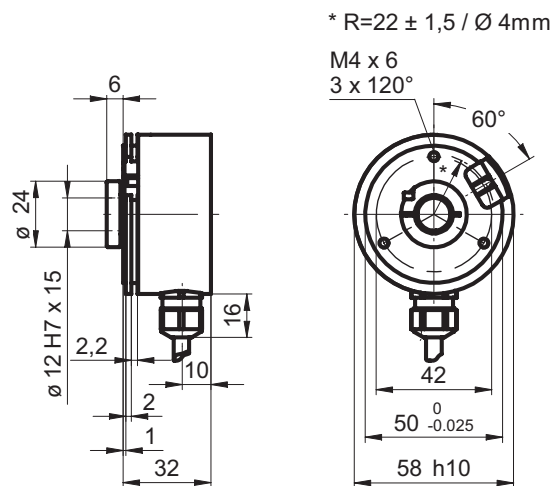

BMSH/BMMH 58 CANopen connector 2 x M12 radial

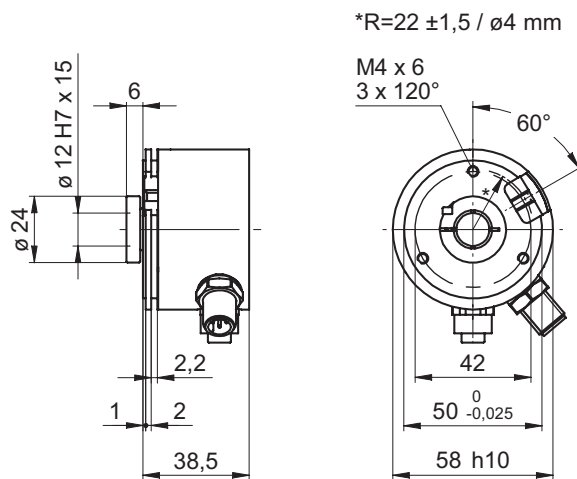

BMSH/BMMH 58 CANopen connector 1 x M12 radial

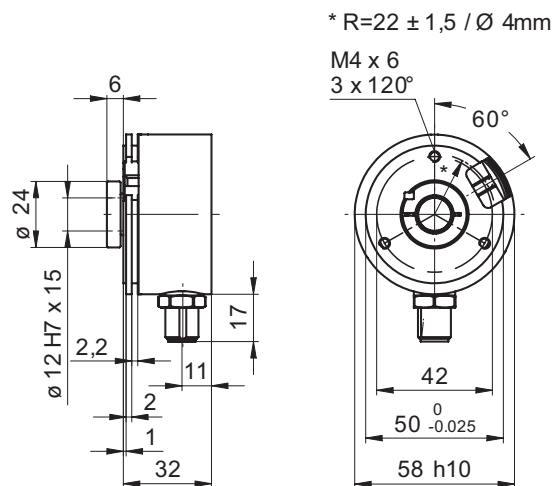

BMSH/BMMH 58 CANopen connector D-SUB radial

