

General Description

It is mainly suitable for low voltage applications such as automotive, DC/DC converters and a load switch in battery powered applications

FEATURES

- $V_{DSS} = 60V$, $I_D = 50A$
- Drain-Source ON Resistance :
- $R_{DS(ON)} = 18m\ \Omega$ (Max.) @ $V_{GS} = 10V$

MOSFET MAXIMUM RATING (Ta=25 °C Unless otherwise noted)

CHARACTERISTIC		SYMBOL	RATING	UNIT
Drain-Source Voltage		V_{DSS}	60	V
Gate-Source Voltage		V_{GSS}	± 25	V
Drain Current	DC	I_D^*	50	A
	Pulsed (Note 1)	I_{DP}	200	A
Drain-Source Diode Forward Current		I_S	50	A
Drain Power Dissipation		P_D^* 25 °C	120	W
Maximum Junction Temperature		T_j	-55 ~ 175	°C
Storage Temperature Range		T_{stg}	-55 ~ 175	°C

Note1) Pulse Test : Pulse width $\leq 10\ \mu S$ Duty cycle $\leq 1\%$

Thermal Characteristics

CHARACTERISTIC	SYMBOL	RATING	UNIT
Thermal Resistance, Junction-to-Ambient	R_{thJA}	62.5	°C/W
Thermal Resistance, Junction-to-Case	R_{thJC}	1.24	°C/W

Equivalent Circuit

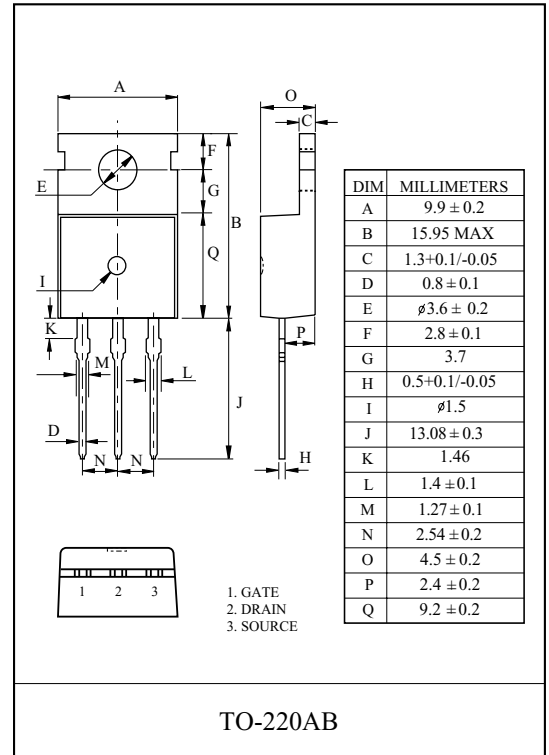
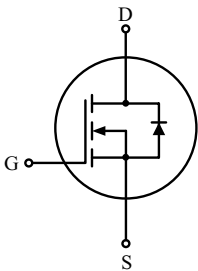

KMB050N60PA

MOSFET Electrical Characteristics (Ta=25 °C Unless otherwise noted)

CHARACTERISTIC	SYMBOL	TEST CONDITION	MIN.	TYP.	MAX.	UNIT
Static						
Drain-Source Breakdown Voltage	BV_{DSS}	$I_D=250\mu A, V_{GS}=0V$	60	-	-	V
Drain Cut-off Current	I_{DSS}	$V_{DS}=60V, V_{GS}=0V,$	-	-	1	μA
Gate Leakage Current	I_{GSS}	$V_{GS}=\pm 25V, V_{DS}=0V$	-	-	± 100	nA
Gate Threshold Voltage	V_{th}	$V_{DS}=V_{GS}, I_D=250\mu A$	2.0	-	4.0	V
Drain-Source ON Resistance	$R_{DS(ON)}$	$V_{GS}=10V, I_D=25A$	-	16	18	m Ω
Forward Transconductance	g_{FS}	$V_{DS}=25V, I_D=25A$	-	22	-	S
Dynamic						
Input Capacitance	C_{iss}	$V_{DS}=25V, V_{GS}=0V, f=1.0MHz$	-	1050	1365	pF
Output Capacitance	C_{oss}		-	70	90	
Reverse Transfer Capacitance	C_{rss}		-	460	600	
Total Gate Charge	Q_g	$V_{DS}=48V,$ $V_{GS}=10V,$ $I_D=25A$ (Note1,2)	-	49	59	nC
Gate-Source Charge	Q_{gs}		-	10	-	
Gate-Drain Charge	Q_{gd}		-	13	-	
Turn-On Delay Time	$t_{d(on)}$	$V_{DD}=30V$ $I_D=25A$ $R_G=25\Omega$ (Note1,2)	-	20	50	ns
Turn-On Rise Time	t_r		-	100	210	
Turn-Off Delay Time	$t_{d(off)}$		-	80	170	
Turn-Off Fall Time	t_f		-	85	185	

Note 1) Pulse Test : Pulse width $\leq 10\mu s$, Duty Cycle $\leq 1\%$.

Note 2) Essentially Independent of Operating Temperature.

DIODE Electrical Characteristics (Ta=25 °C Unless otherwise noted)

CHARACTERISTIC	SYMBOL	TEST CONDITION	MIN.	TYP.	MAX.	UNIT
Diode Forward Voltage	V_{SD}	$I_{SD}=50A, V_{GS}=0V$	-	-	1.5	V
Reverse Recovery Time	T_{rr}	$V_{GS}=0V, I_S=50A, diF/dt=100A/\mu s$	-	50	-	ns

Marking

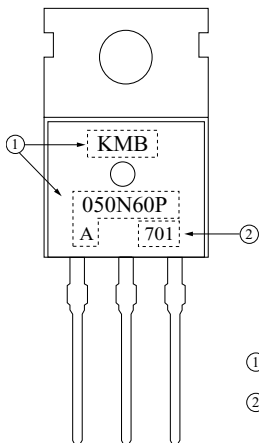

① PRODUCT NAME

② LOT NO

KMB050N60PA

Fig 1. $I_D - V_{DS}$

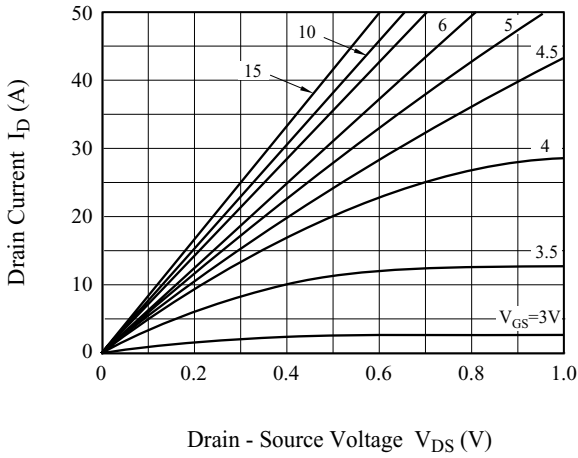

Fig 2. $I_D - V_{GS}$

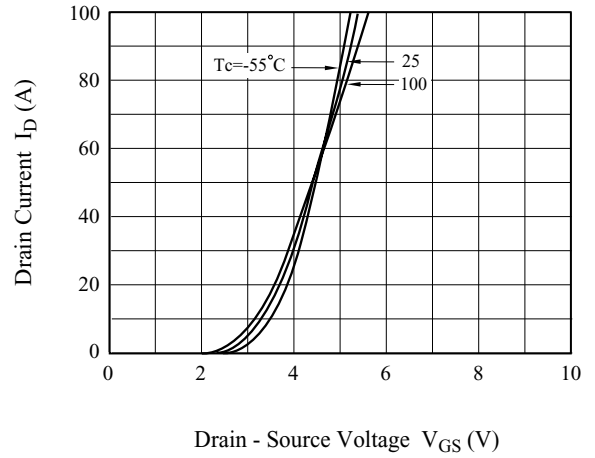

Fig 3. $BV_{DSS} - T_j$

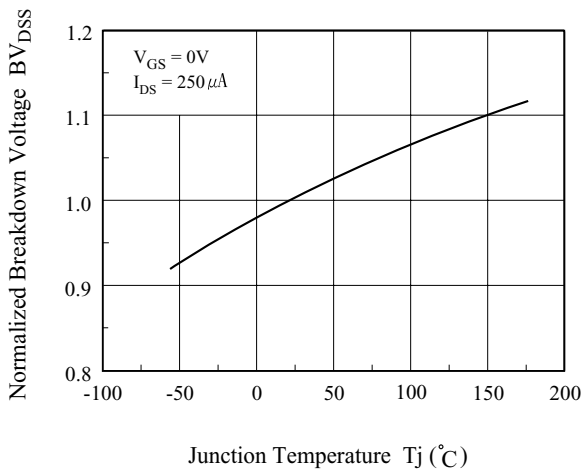

Fig 4. $R_{DS(ON)} - I_D$

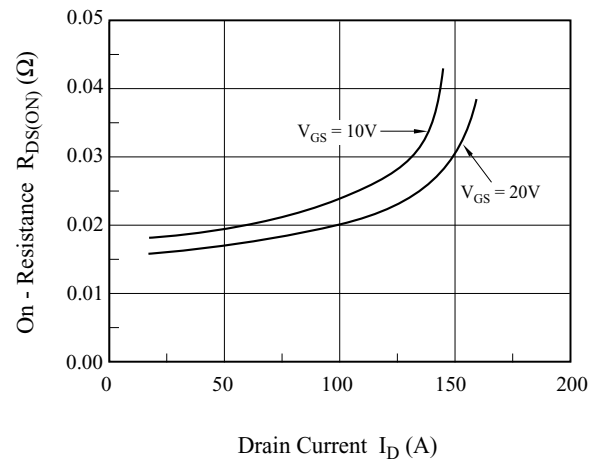

Fig 5. $I_S - V_{SD}$

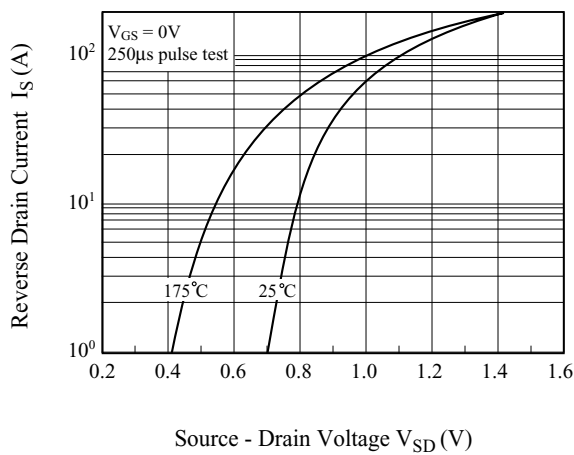
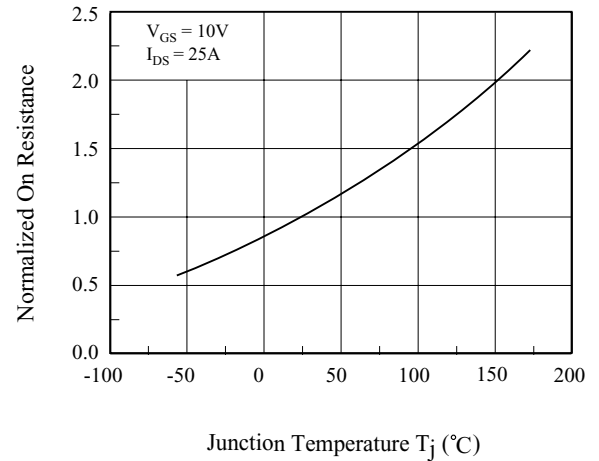

Fig 6. $R_{DS(ON)} - T_j$



KMB050N60PA

Fig 7. C - V_{DS}

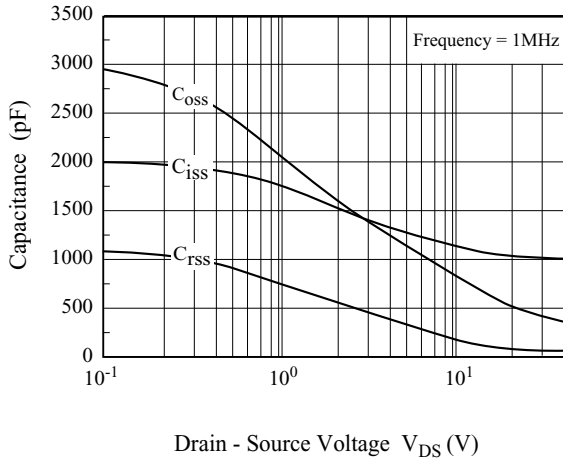

Fig 8. Q_g - V_{GS}

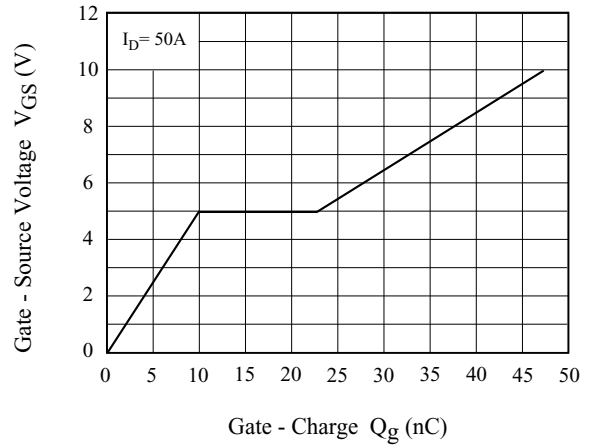

Fig 9. Safe Operation Area

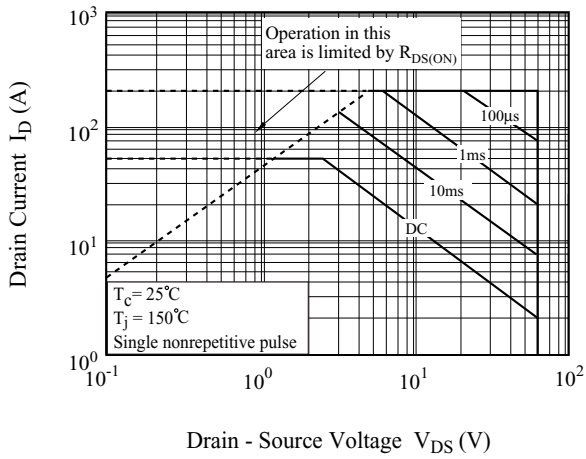

Fig 10. I_D - T_j

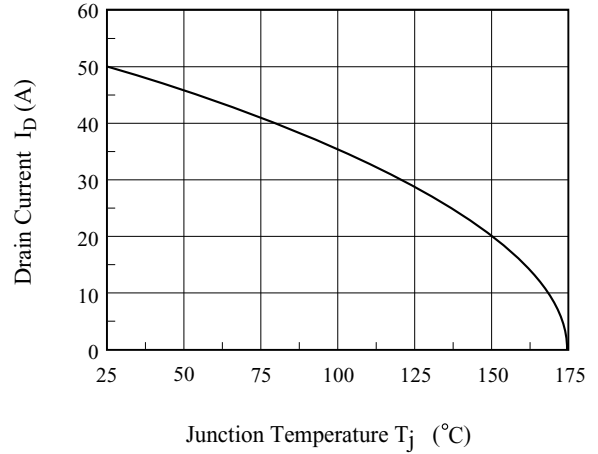
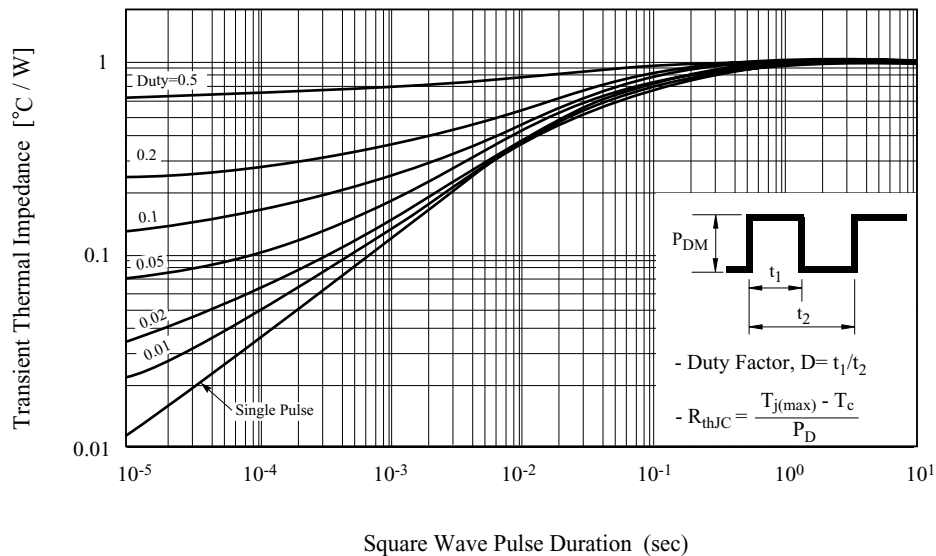
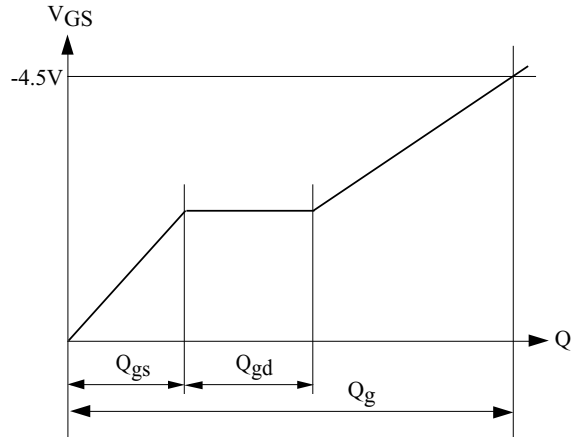
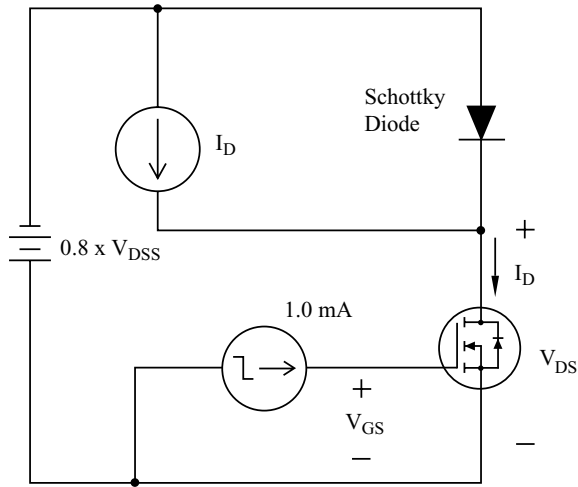

Fig 11. R_{th}



KMB050N60PA

- Gate Charge



- Resistive Load Switching

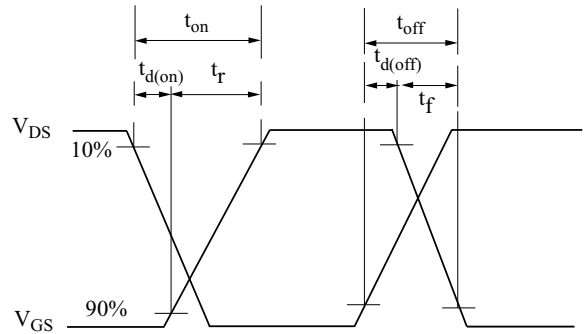
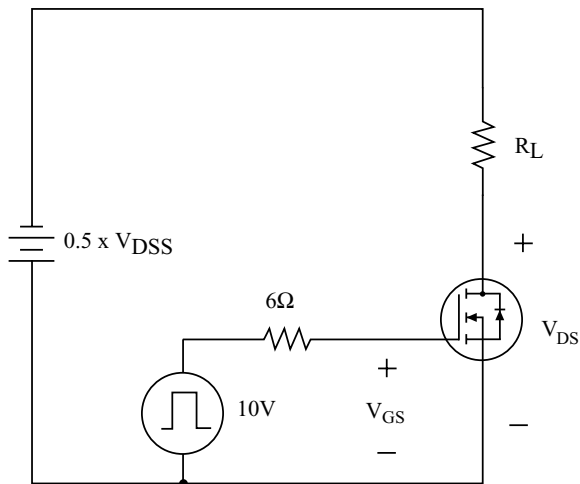

- Single Pulsed Avalanche Energy

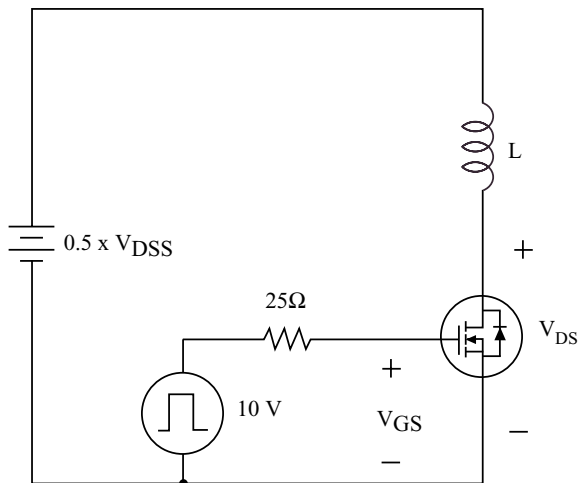

$$E_{AS} = \frac{1}{2} I_{AS}^2 \frac{BV_{DSS}}{BV_{DSS} - V_{DD}}$$

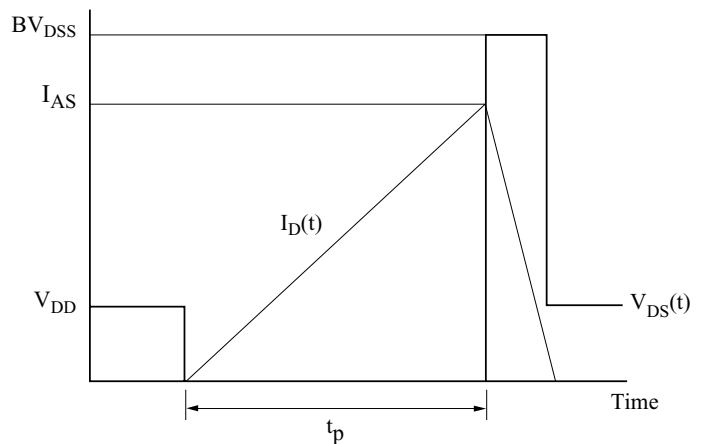

KMB050N60PA

- Source - Drain Diode Reverse Recovery and dv/dt

