

## General Description

The AAT1239-1 is a high frequency, high efficiency constant current boost converter capable of driving up to ten (10) series-connected white LEDs or 40V. It is an ideal power solution for backlight applications with up to ten white LEDs in series. The input voltage is 2.7V to 5.5V for single-cell lithium-ion/polymer (Li-ion) based portable devices.

The LED current is digitally controlled across a 6x operating range using AnalogicTech's Simple Serial Control™ (S<sup>2</sup>Cwire™) interface. Programmability across 26 discrete current steps provides high resolution, low noise, flicker-free, constant LED outputs. In programming AAT1239 operation, LED brightness increases based on the data applied at the EN/SET pin. The SEL logic pin changes the feedback voltage between two programmable ranges.

The AAT1239-1 features a high current limit and fast, stable transitions for stepped or pulsed current applications. The high switching frequency (up to 2MHz) provides fast response and allows the use of ultra-small external components, including chip inductors and capacitors. Fully integrated control circuitry simplifies design and reduces total solution size. The AAT1239-1 offers a true load disconnect feature which isolates the load from the power source while in the OFF or disabled state. This eliminates leakage current, making the devices ideally suited for battery-powered applications.

The AAT1239-1 is available in the Pb-free, thermally-enhanced 12-pin TSOPJW package.

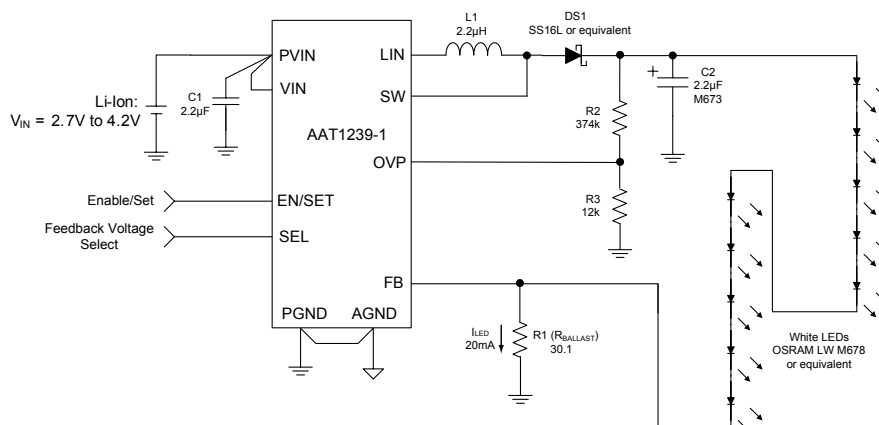
## Features

- Input Voltage Range: 2.7V to 5.5V
- Maximum Continuous Output 40V @ 30mA
- Drives up to 10 LEDs in Series
  - Constant LED Current with 3.5% Accuracy Over Temperature and Input Voltage Range
- Digital Control with S<sup>2</sup>Cwire Single Wire Interface
  - 26 Discrete Steps
  - No PWM Control Required
  - No Additional Circuitry
- Up to 85% Efficiency
- Up to 2MHz Switching Frequency Allows Small External Chip Inductor and Capacitors
- Hysteretic Control
  - No External Compensation Components
  - Excellent Load Transient Response
  - High Efficiency at Light Loads
- Integrated Soft Start with No External Capacitor
- True Load Disconnect Guarantees <1.0µA Shutdown Current
- Selectable Feedback Voltage Ranges for High Resolution Control of Load Current
- Short-Circuit, Over-Voltage, and Over-Temperature Protection
- 12-Pin TSOPJW Package
- -40°C to +85°C Temperature Range

## Applications

- Color Display Backlight
- Digital Still Cameras (DSCs)
- Digital Photo Frames
- PDAs and Notebook PCs
- White LED Drivers

## Typical Application

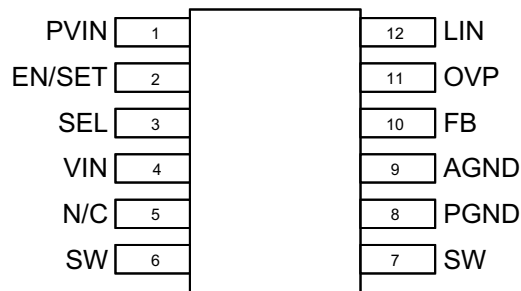


### Pin Descriptions

Pin #	Symbol	Function
1	PVIN	Input power pin; connected to the source of the P-channel MOSFET. Connect to the input capacitor(s).
2	EN/SET	IC enable pin and S <sup>2</sup> Cwire input control to set output current.
3	SEL	FB voltage range select. A logic LOW sets the FB voltage range from 0.4V to 0.1V; a logic HIGH sets the FB voltage range from 0.6V to 0.3V.
4	VIN	Input voltage for the converter. Connect directly to the PVIN pin.
5	N/C	No connection.
6, 7	SW	Boost converter switching node. Connect the power inductor between this pin and LIN.
8	PGND	Power ground for the boost converter.
9	AGND	Ground pin.
10	FB	Feedback pin. Connect a resistor to ground to set the maximum LED current.
11	OVP	Feedback pin for over-voltage protection sense.
12	LIN	Switched power input. Connect the power inductor between this pin and SW.

### Pin Configuration

**TSOPJW-12  
(Top View)**



## Part Number Descriptions

Part Number	SEL Polarity		S <sup>2</sup> C Feedback Voltage Programming
	HIGH	LOW	
AAT1239ITP-1	$0.6V \geq V_{FB} \geq 0.3V$	$0.4V \geq V_{FB} \geq 0.1V$	See Table 2

## Absolute Maximum Ratings<sup>1</sup>

T<sub>A</sub> = 25°C unless otherwise noted.

Symbol	Description	Value	Units
PVIN, VIN	Input Voltage	-0.3 to 6.0	V
SW	Switching Node	45	V
LIN, EN/SET, SEL, FB	Maximum Rating	V <sub>IN</sub> + 0.3	V
T <sub>J</sub>	Operating Temperature Range	-40 to 150	°C
T <sub>S</sub>	Storage Temperature Range	-65 to 150	°C
T <sub>LEAD</sub>	Maximum Soldering Temperature (at leads, 10 sec)	300	°C

## Thermal Information

Symbol	Description	Value	Units
θ <sub>JA</sub>	Thermal Resistance	160	°C/W
P <sub>D</sub>	Maximum Power Dissipation	625	mW

1. Stresses above those listed in Absolute Maximum Ratings may cause permanent damage to the device. Functional operation at conditions other than the operating conditions specified is not implied. Only one Absolute Maximum Rating should be applied at any one time.

## Electrical Characteristics<sup>1</sup>

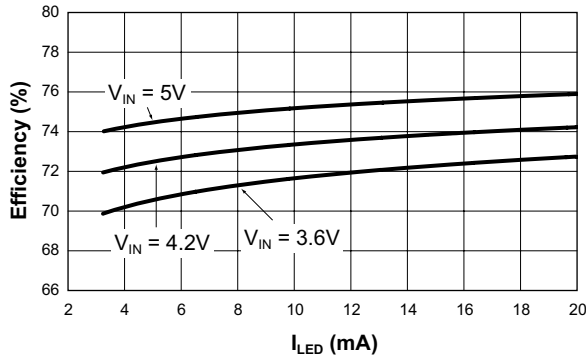
T<sub>A</sub> = -40°C to +85°C unless otherwise noted. Typical values are at 25°C, V<sub>IN</sub> = 3.6V.

Symbol	Description	Conditions	Min	Typ	Max	Units
<b>Power Supply</b>						
PV <sub>IN</sub> , V <sub>IN</sub>	Input Voltage Range		2.7		5.5	V
V <sub>OUT(MAX)</sub>	Maximum Output Voltage				40	V
I <sub>Q</sub>	Operating Current	SEL = GND, FB = 0.1V			70	μA
I <sub>SHDN</sub>	Shutdown Current	EN/SET = GND			1.0	μA
I <sub>OUT</sub>	Maximum Continuous Output Current <sup>2</sup>	2.7V < V <sub>IN</sub> < 5.5V, V <sub>OUT</sub> = 40V			30	mA
ΔV <sub>LINEREG(FB)</sub> /ΔV <sub>IN</sub>	Line Regulation	V <sub>IN</sub> = 2.7V to 5.5V, V <sub>FB</sub> = 0.6V		0.7		%
R <sub>DS(ON) L</sub>	Low Side Switch On Resistance			135		mΩ
R <sub>DS(ON) IN</sub>	Input Disconnect Switch On Resistance			180		mΩ
T <sub>SS</sub>	Soft-Start Time	From Enable to Output Regulation; V <sub>FB</sub> = 300mV		400		μs
V <sub>OV</sub> P	Over-Voltage Protection Threshold	V <sub>OUT</sub> Rising	1.1	1.2	1.3	V
	Over-Voltage Hysteresis	V <sub>OUT</sub> Falling		100		mV
I <sub>LIMIT</sub>	N-Channel Current Limit			2.5		A
T <sub>SD</sub>	T <sub>J</sub> Thermal Shutdown Threshold			140		°C
T <sub>HYS</sub>	T <sub>J</sub> Thermal Shutdown Hysteresis			15		°C
<b>SEL, EN/SET</b>						
V <sub>SEL(L)</sub>	SEL Threshold Low				0.4	V
V <sub>SEL(H)</sub>	SEL Threshold High		1.4			V
V <sub>EN/SET(L)</sub>	Enable Threshold Low				0.4	V
V <sub>EN/SET(H)</sub>	Enable Threshold High		1.4			V
T <sub>EN/SET (LO)</sub>	EN/SET Low Time	V <sub>EN/SET</sub> < 0.6V	0.3		75	μs
T <sub>EN/SET(HI)</sub>	EN/SET High Time	V <sub>EN/SET</sub> > 1.4V			75	μs
T <sub>OFF</sub>	EN/SET Off Timeout	V <sub>EN/SET</sub> < 0.6V			500	μs
T <sub>LAT</sub>	EN/SET Latch Timeout	V <sub>EN/SET</sub> > 1.4V			500	μs
I <sub>EN/SET</sub>	EN/SET Input Leakage	V <sub>EN/SET</sub> = 5V V <sub>IN</sub> = 5V	-1		1	μA
<b>AAT1239-1</b>						
V <sub>FB</sub>	FB Pin Regulation	V <sub>IN</sub> = 2.7V to 5.5V, SEL = GND, EN/SET = DATA16	0.085	0.1	1.115	V
		V <sub>IN</sub> = 2.7V to 5.5V, SEL = HIGH, EN/SET = HIGH	0.54	0.6	0.66	

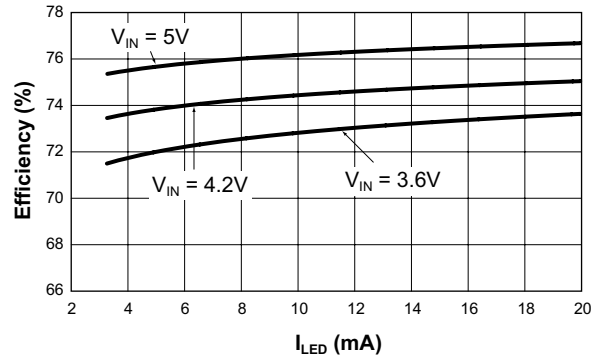
1. Specification over the -40°C to +85°C operating temperature range is assured by design, characterization, and correlation with statistical process controls.  
 2. Maximum continuous output current increases with reduced output voltage, but may vary depending on operating efficiency and thermal limitations.

**Typical Characteristics**

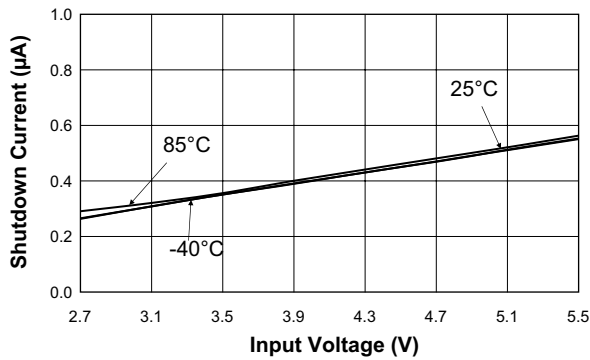
**Efficiency vs. LED Current**  
(10 White LEDs;  $R_{BALLAST} = 30.1\Omega$ )



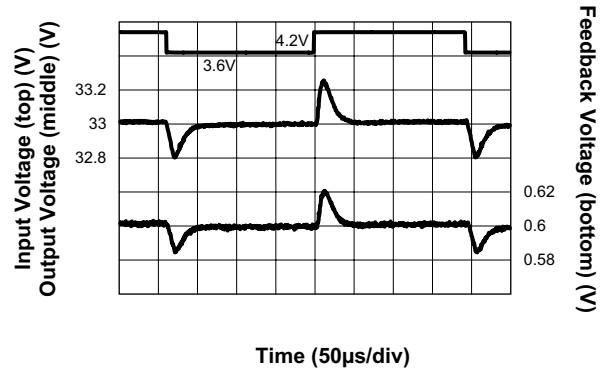
**Efficiency vs. LED Current**  
(9 White LEDs;  $R_{BALLAST} = 30.1\Omega$ )



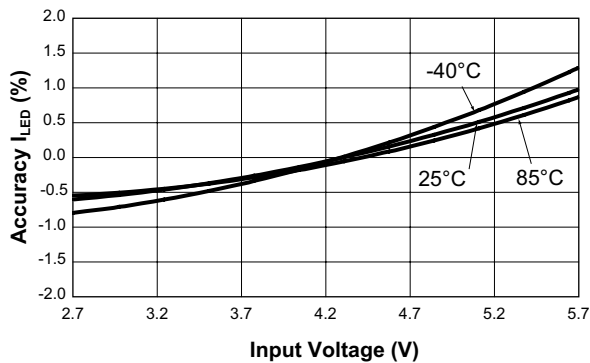
**Shutdown Current vs. Input Voltage**  
(EN = GND)



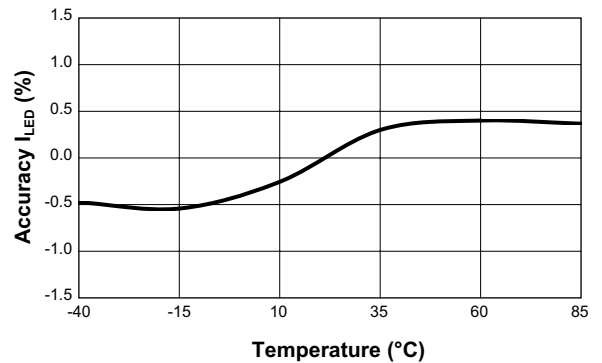
**Line Transient**  
(10 White LEDs;  $R_{BALLAST} = 30.1\Omega$ )



**Accuracy  $I_{LED}$  vs. Input Voltage**  
( $V_{FB} = 0.6V$ ;  $R_{BALLAST} = 30.1\Omega$ )

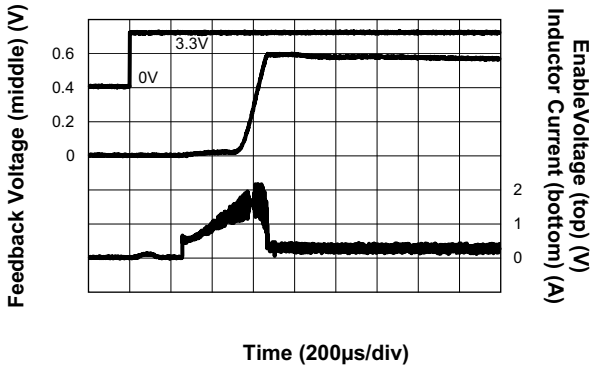


**Accuracy  $I_{LED}$  vs. Temperature**  
( $V_{FB} = 0.6V$ ;  $R_{BALLAST} = 30.1\Omega$ )

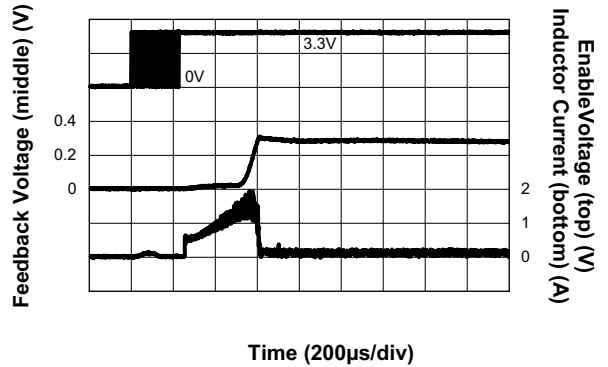


**Typical Characteristics**

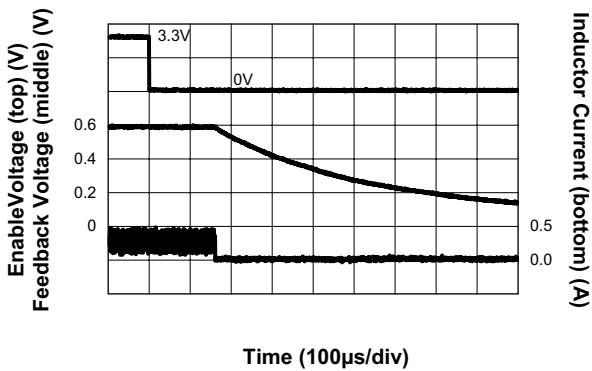
**Soft Start**  
(10 White LEDs;  $V_{FB} = 0.6V$ )



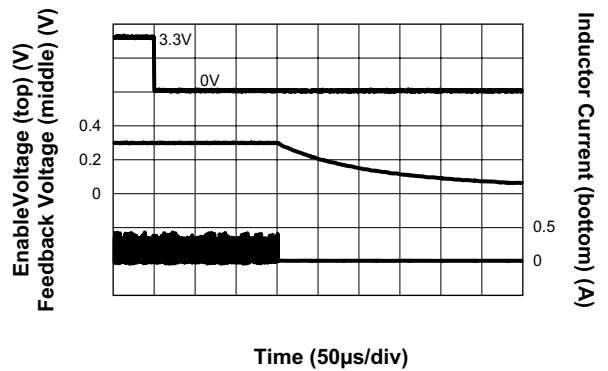
**Soft Start**  
(10 White LEDs;  $V_{FB} = 0.3V$ )



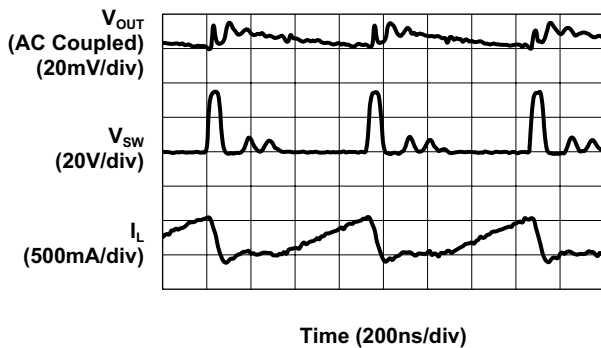
**Shutdown**  
(10 White LEDs;  $V_{FB} = 0.6V$ )



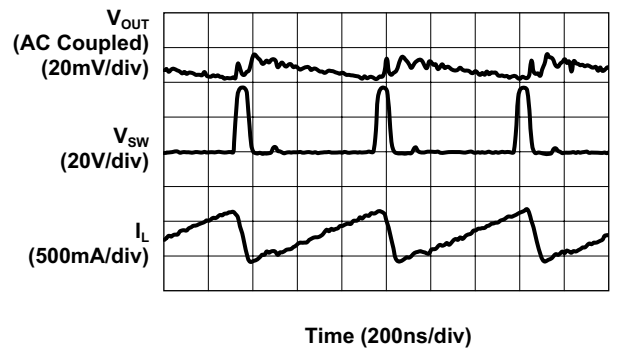
**Shutdown**  
(10 LEDs;  $V_{FB} = 0.3V$ )



**Output Ripple**  
(10 White LEDs;  $V_{IN} = 3.6V$ ;  $C_{OUT} = 2.2µF$ ;  $I_{LED} = 13mA$ )

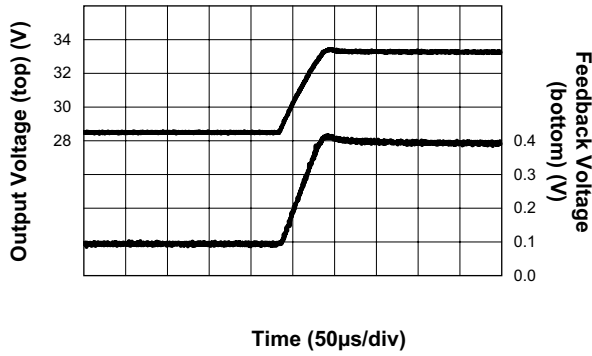


**Output Ripple**  
(10 White LEDs;  $V_{IN} = 3.6V$ ;  $C_{OUT} = 2.2µF$ ;  $I_{LED} = 20mA$ )

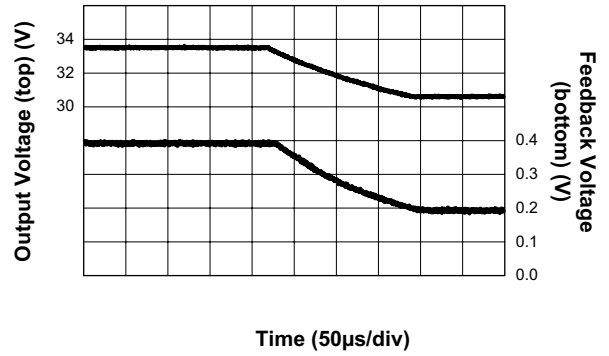


**Typical Characteristics**

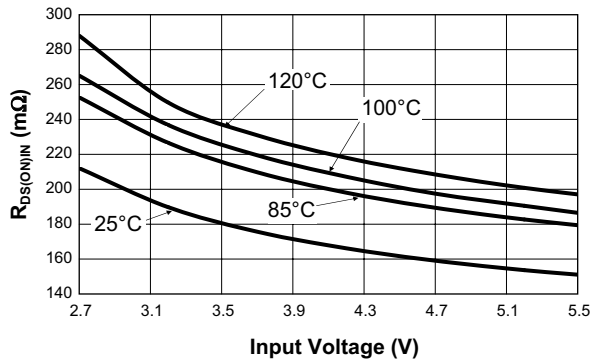
**Transition of LED Current**  
(10 White LEDs; SEL = Low;  $I_{LED} = 3mA$  to  $13mA$ )



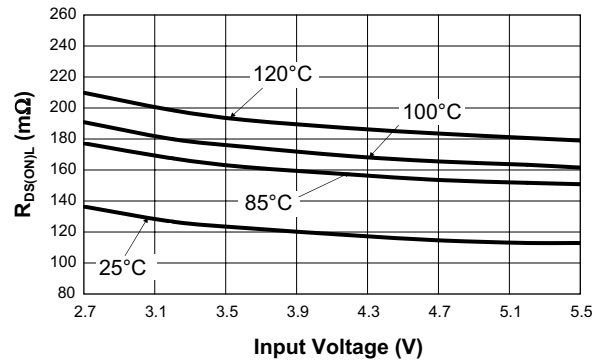
**Transition of LED Current**  
(10 White LEDs; SEL = Low;  $I_{LED} = 13mA$  to  $6mA$ )



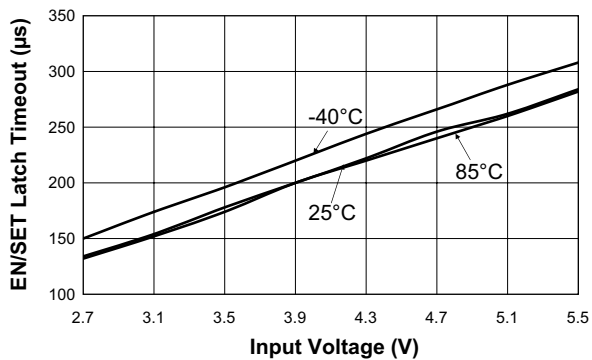
**Input Disconnect Switch Resistance vs. Input Voltage**



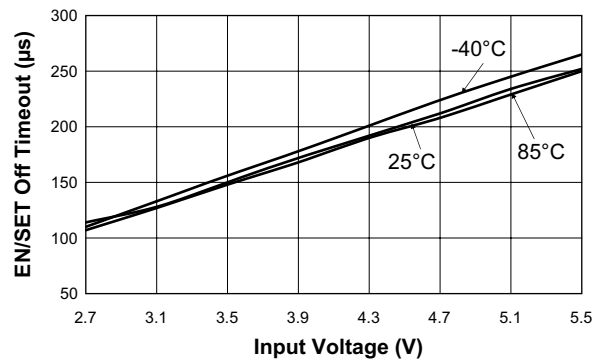
**Low Side Switch On Resistance vs. Input Voltage**



**EN/SET Latch Timeout vs. Input Voltage**

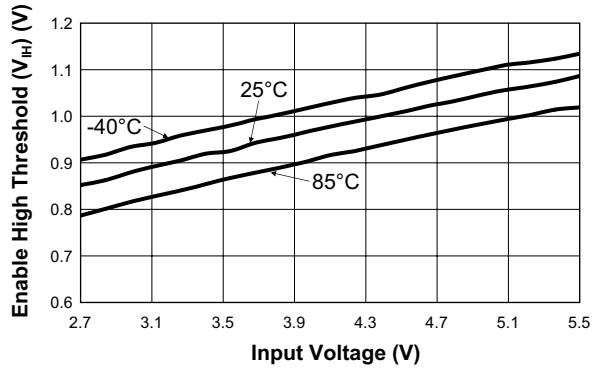


**EN/SET Off Timeout vs. Input Voltage**

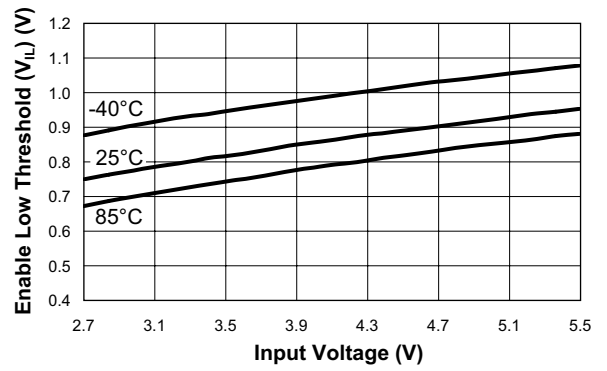


**Typical Characteristics**

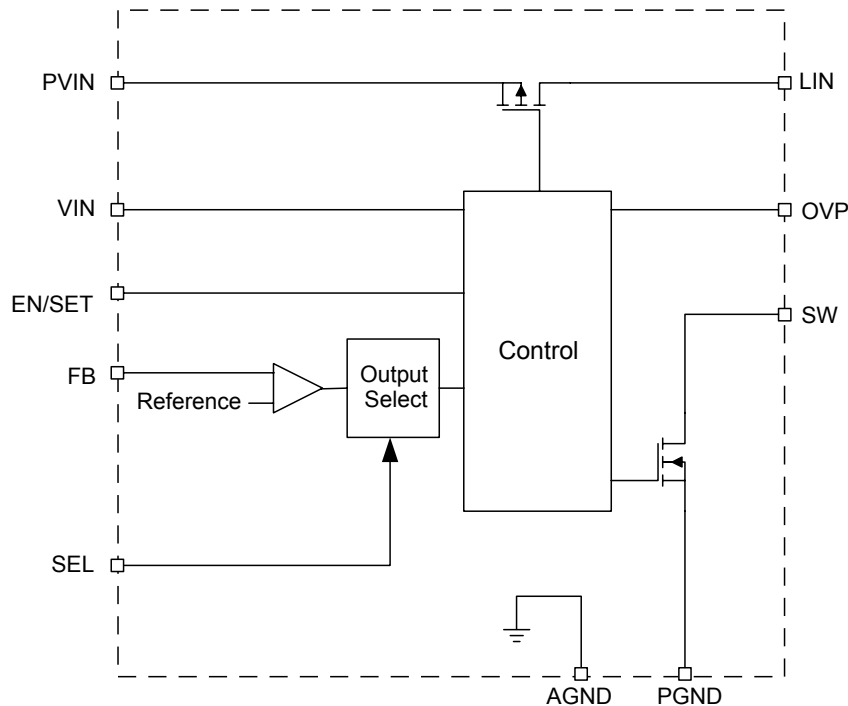
Enable High Threshold ( $V_{IH}$ ) vs. Input Voltage



Enable Low Threshold ( $V_{IL}$ ) vs. Input Voltage



## Functional Block Diagram



## Functional Description

The AAT1239-1 consists of a DC/DC boost controller, an integrated slew rate controlled input disconnect MOSFET switch, and a high voltage MOSFET power switch. A high voltage rectifier, power inductor, output capacitor, and sense resistors are required to implement a DC/DC constant current boost converter. The input disconnect switch is activated when a valid input voltage is present and the EN/SET pin is pulled high. The slew rate control on the P-channel MOSFET ensures minimal inrush current as the output voltage is charged to the input voltage, prior to the switching of the N-channel power MOSFET. Monotonic turn-on is guaranteed by the integrated soft-start circuitry. Soft-start eliminates output voltage overshoot across the full input voltage range and all loading conditions.

The maximum current through the LED string is set by the ballast resistor and the feedback voltage of the IC. The output current may be programmed by adjusting the level of the feedback reference voltage which is programmed through the S<sup>2</sup>Cwire interface. The SEL pin selects one of two feedback voltage ranges. In the AAT1239-1, the SEL function is inverted in that the FB pin voltage can be programmed from 0.4V to 0.1V with

a logic LOW applied to the SEL pin and 0.6V to 0.3V with a logic HIGH applied to the SEL pin. The feedback voltage can be set to any one of 16 current levels within each FB range, providing high-resolution control of the LED current, using the single-wire S<sup>2</sup>Cwire control.

For some applications requiring a short duration of boosting current applying a low-to-high transition on the AAT1239-1's SEL pin, LED current can be programmed up to 3x. The step size is determined by the programmed voltage at the FB pin where the internal default setting is 1.5x in the AAT1239-1.

## Control Loop

The AAT1239-1 provides the benefits of current mode control with a simple hysteretic output current loop providing exceptional stability and fast response with minimal design effort. The device maintains exceptional constant current regulation, transient response, and cycle-by-cycle current limit without additional compensation components.

The AAT1239-1 modulates the power MOSFET switching current to maintain the programmed FB voltage. This allows the FB voltage loop to directly program the

required inductor current in order to maintain the desired LED current.

The switching cycle initiates when the N-channel MOSFET is turned ON and current ramps up in the inductor. The ON interval is terminated when the inductor current reaches the programmed peak current level. During the OFF interval, the input current decays until the lower threshold, or zero inductor current, is reached. The lower current is equal to the peak current minus a preset hysteresis threshold, which determines the inductor ripple current. The peak current is adjusted by the controller until the LED output current requirement is met.

The magnitude of the feedback error signal determines the average input current. Therefore, the AAT1239-1 controller implements a programmed current source connected to the output capacitor, parallel with the LED string and ballast resistor. There is no right-half plane zero, and loop stability is achieved with no additional compensation components.

An increase in the feedback voltage ( $V_{FB}$ ) results in an increased error signal sensed across the ballast resistor ( $R_1$ ). The controller responds by increasing the peak inductor current, resulting in higher average current in the inductor and LED string(s). Alternatively, when the  $V_{FB}$  is reduced, the controller responds by decreasing the peak inductor current, resulting in lower average current in the inductor and LED string(s).

Under light load conditions, the inductor OFF interval current goes below zero and the boost converter enters discontinuous mode operation. Further reduction in the load current results in a corresponding reduction in the switching frequency. The AAT1239-1 provides pulsed frequency operation which reduces switching losses and maintains high efficiency under light load conditions.

Operating frequency varies with changes in the input voltage, output voltage, and inductor size. Once the boost converter has reached continuous mode, further increases in the LED current will not significantly change the operating frequency. A small  $2.2\mu\text{H}$  ( $\pm 20\%$ ) inductor is selected to maintain high frequency switching (up to 2MHz) and high efficiency operation for outputs up to 40V.

### **Soft Start / Enable**

The input disconnect switch is activated when a valid input voltage is present and the EN/SET pin is pulled high. The slew rate control on the P-channel MOSFET ensures minimal inrush current as the output voltage is charged to the input voltage, prior to switching of the

N-channel power MOSFET. Monotonic turn-on is guaranteed by the built-in soft-start circuitry. Soft start eliminates output current overshoot across the full input voltage range and all loading conditions.

After the soft start sequence has terminated, the initial LED current is determined by the internal, default FB voltage across the external ballast resistor at the FB pin. Additionally, the AAT1239-1 has been designed to offer the system designer two choices for the default FB voltage based on the state of the SEL pin. Changing the LED current from its initial default setting is easy by using the S<sup>2</sup>Cwire single wire serial interface; the FB voltage can be decreased (as in the AAT1239-1; see Table 2) relative to the default FB voltage.

### **Current Limit and Over-Temperature Protection**

The switching of the N-channel MOSFET terminates when a current limit of 2.5A (typical) is exceeded. This minimizes power dissipation and component stresses under overload and short-circuit conditions. Switching resumes when the current decays below the current limit.

Thermal protection disables the AAT1239-1 when internal dissipation becomes excessive. Thermal protection disables both MOSFETs. The junction over-temperature threshold is 140°C with 15°C of temperature hysteresis. The output voltage automatically recovers when the over-temperature fault condition is removed.

### **Over-Voltage Protection**

Over-voltage protection prevents damage to the AAT1239-1 during open-circuit or high output voltage conditions. An over-voltage event is defined as a condition where the voltage on the OVP pin exceeds the over-voltage threshold limit ( $V_{OVP} = 1.2\text{V}$  typical). When the voltage on the OVP pin has reached the threshold limit, the converter stops switching and the output voltage decays. Switching resumes when the voltage on the OVP pin drops below the lower hysteresis limit, maintaining an average output voltage between the upper and lower OVP thresholds multiplied by the resistor divider scaling factor.

### **Under-Voltage Lockout**

Internal bias of all circuits is controlled via the VIN input. Under-voltage lockout (UVLO) guarantees sufficient  $V_{IN}$  bias and proper operation of all internal circuitry prior to soft start.

**Application Information**

**Over-Voltage Protection**

**OVP Protection with Open Circuit Failure**

The OVP protection circuit consists of a resistor network tied from the output voltage to the OVP pin (see Figure 1). To protect the device from open circuit failure, the resistor divider can be selected such that the over-voltage threshold occurs prior to the output reaching 40V ( $V_{OUT(MAX)}$ ). The value of R3 should be selected from 10kΩ to 20kΩ to minimize losses without degrading noise immunity.

Assume  $R_3 = 12k\Omega$  and  $V_{OUT(MAX)} = 40V$ . Selecting 1% resistor for high accuracy, this results in  $R_2 = 374k\Omega$  (rounded to the nearest standard value). The minimum OVP threshold can be calculated:

$$V_{OUT(OVP\_MIN)} = V_{OVP(MIN)} \cdot \left( \frac{R_2}{R_3} + 1 \right) = 35.4V$$

To avoid OVP detection and subsequent reduction in the programmed output current (see following section), the maximum operating voltage should not exceed the minimum OVP set point.

$$R_2 = R_3 \cdot \frac{V_{OUT(MAX)}}{V_{OVP}} - 1$$

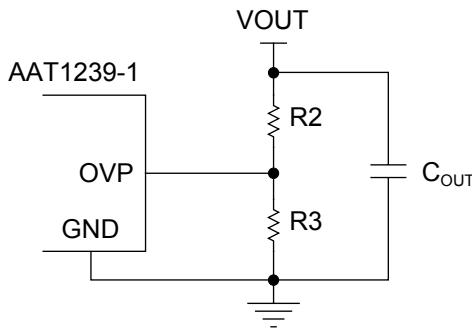
$$V_{OUT(MAX)} < V_{OUT(OVP\_MIN)}$$

In some cases, this may disallow configurations with high LED forward voltage ( $V_{FLED}$ ) and/or greater than ten series white LEDs.  $V_{FLED}$  unit-to-unit tolerance can be as high as +15% of nominal for white LED devices.

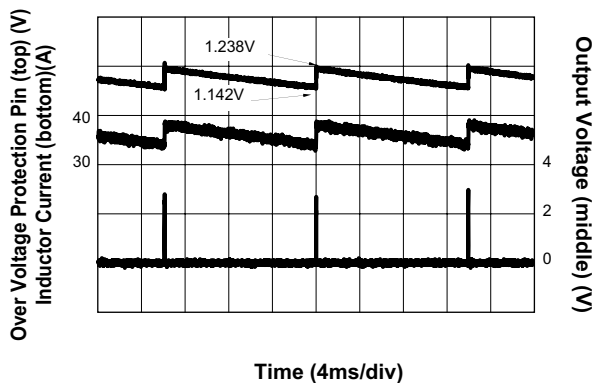
**OVP Constant Voltage Operation**

Under closed loop constant current conditions, the output voltage is determined by the operating current, LED forward voltage characteristics ( $V_{FLED}$ ), quantity of series connected LEDs (N), and the feedback pin voltage ( $V_{FB}$ ).

$$V_{OUT} = V_{FB} + N \cdot V_{FLED}$$



**Figure 1: Over-Voltage Protection Circuit.**



**Figure 2: Over-Voltage Protection Open Circuit Response (No LED).**

When the rising OVP threshold is exceeded, switching is stopped and the output voltage decays. Switching automatically restarts when the output drops below the lower OVP hysteresis voltage (100mV typical) and, as a result, the output voltage increases. The cycle repeats, maintaining an average DC output voltage proportional to the average of the rising and falling OVP levels (multiplied by the resistor divider scaling factor). High operating frequency and small output voltage ripple ensure DC current and negligible flicker in the LED string(s).

The waveform in Figure 3 shows the output voltage and LED current at cold temperature with a ten series white LED string and  $V_{OVP} = 40V$ . As shown, the output voltage rises as a result of the increased  $V_{FLED}$  which triggers the OVP constant voltage operation. Self heating of the LEDs triggers a smooth transition back to constant current control.



**Figure 3: Over-Voltage Protection Constant Voltage Operation (10 White LEDs;  $I_{LED} = 20\text{mA}$ ;  $R_2 = 12\text{k}\Omega$ ;  $R_3 = 374\text{k}\Omega$ ).**

While OVP is active, the maximum LED current programming error ( $\Delta I_{LED}$ ) is proportional to voltage error across an individual LED ( $\Delta V_{FLED}$ ).

$$\Delta V_{FLED} = \frac{(N \cdot V_{FLED(TYP)} - V_{OUT(OVP\_MIN)} - V_{FB})}{N}$$

To minimize the  $\Delta I_{LED}$  error, the minimum OVP voltage ( $V_{OUT(OVP\_MIN)}$ ) may be increased, yielding a corresponding increase in the maximum OVP voltage ( $V_{OUT(OVP\_MAX)}$ ). Measurements should confirm that the maximum switching node voltage ( $V_{SW(MAX)}$ ) is less than 45V under worst-case operating conditions.

$$V_{SW(MAX)} = V_{OVP(MAX)} \cdot \left( \frac{R_3}{R_2} + 1 \right) + V_F + V_{RING}$$

$V_F$  = -Schottky Diode DS1 forward voltage at turn-OFF

$V_{RING}$  = Voltage ring occurring at turn-OFF

### LED Selection and Current Setting

The AAT1239-1 is well suited for driving white LEDs with constant current. Applications include main and sub-LCD display backlighting, and color LEDs.

The LED current is controlled by the FB voltage and the ballast resistor. For maximum accuracy, a 1% tolerance resistor is recommended.

The ballast resistor ( $R_{BALLAST}$ ) value can be calculated as follows:

$$R_{BALLAST} = \frac{V_{FB(MAX)}}{I_{LED(MAX)}}$$

where:

$$V_{FB(MAX)} = 0.4\text{V when SEL = Low}$$

$$V_{FB(MAX)} = 0.6\text{V when SEL = High}$$

i.e., for a maximum LED current of 20mA (SEL = High):

$$R_{BALLAST} = \frac{V_{FB}}{I_{LED(MAX)}} = \frac{0.6}{0.020} = 30\Omega \approx 30.1\Omega$$

Maximum $I_{LED}$ Current (mA)	$R_{BALLAST}$ ( $\Omega$ )	
	SEL = High	SEL = Low
30	20.0	13.3
25	24.3	16.2
20	30.1	20.0
15	40.2	26.7
10	60.4	40.2
5	121.0	80.6

**Table 1: Maximum LED Current and  $R_{BALLAST}$  Resistor Values (1% Resistor Tolerance).**

Typical white LEDs are driven at maximum continuous currents of 15mA to 20mA. The maximum number of series connected LEDs is determined by the minimum OVP voltage of the boost converter ( $V_{OUT(OVP\_MIN)}$ ), minus the maximum feedback voltage ( $V_{FB(MAX)}$ ) divided by the maximum LED forward voltage ( $V_{FLED(MAX)}$ ).  $V_{FLED(MAX)}$  can be estimated from the manufacturers' datasheet at the maximum LED operating current.

$$V_{OUT(OVP\_MIN)} = V_{OVP(TYP)} \cdot \left( \frac{R_2}{R_3} + 1 \right)$$

$$N = \frac{(V_{OUT(OVP\_MIN)} - V_{FB(MAX)})}{V_{FLED(MAX)}}$$

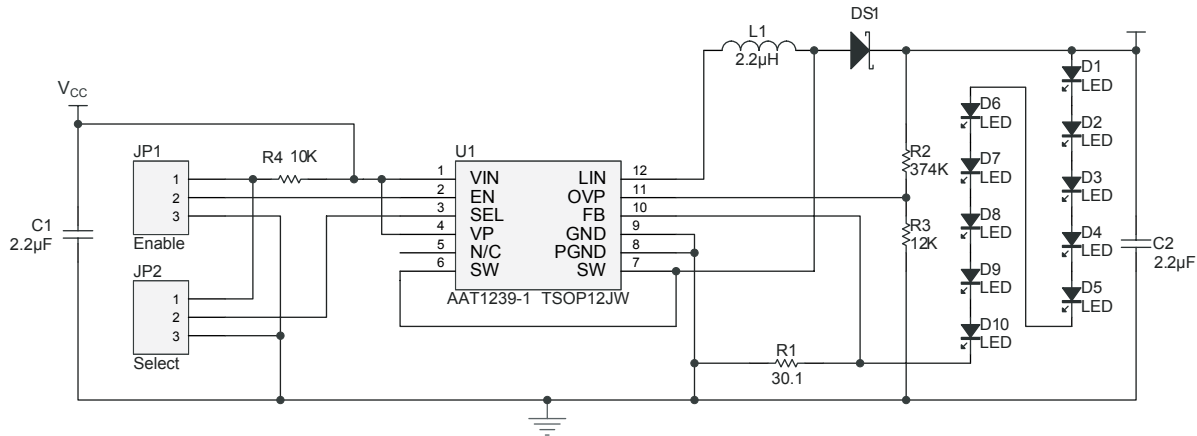
Figure 4 shows the schematic of using ten LEDs in series. Assume  $V_{FLED}$  @ 20mA = 3.5V (typical) from LW M673 (OSRAM) datasheet.

$$V_{OUT(OVP\_MIN)} = 1.2\text{V} \cdot \left( \frac{374\text{k}\Omega}{10.4\text{k}\Omega} + 1 \right) = 38.6\text{V}$$

$$N = \frac{38.6\text{V} - 0.6\text{V}}{3.5\text{V}}$$

$$\approx 10.9$$

Therefore, under these typical operating conditions, ten LEDs can be used in series.



C1 10V 0603 X5R 2.2µF GRM188R60J225KE01D  
 C2 50V 1206 X7R 2.2µF GRM31CR71H225KA88  
 L1 2.2µH SD3814-2R2 or SD3110-2R2  
 DS1 SS16L  
 D1-D10 LW M673 White LED

other alternatives:  
 more stability at 40V: C2 50V 1206 X7R 4.7µF GRM31CR71H475K  
 under 20V application: C2 25V 0805 X7R 2.2µF GRM21BR71E225KA73L

**Figure 4: AAT1239-1 White LED Boost Converter Schematic.**

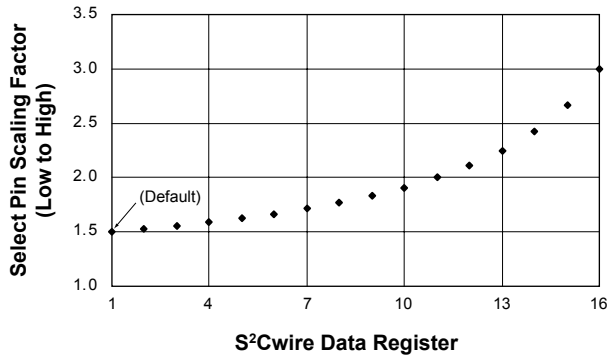
**LED Brightness Control**

The AAT1239-1 uses S<sup>2</sup>Cwire programming to control LED brightness and does not require PWM (pulse width modulation) or additional control circuitry. This feature greatly reduces the burden on a microcontroller or system IC to manage LED or display brightness, allowing the user to “set it and forget it.” With its high-speed serial interface (1MHz data rate), the output current of the AAT1239-1 can be changed successively to brighten or dim the LEDs in smooth transitions (i.e., to fade out) or in abrupt steps, giving the user complete programmability and real-time control of LED brightness.



**Figure 5: Programming AAT1239-1 LED Current with R<sub>BALLAST</sub> = 30.1Ω.**

Alternatively, toggling the SEL logic pin from low to high implements stepped or pulsed LED currents by increasing the FB pin voltage. Figure 6 illustrates the SELECT pin scaling factor, defined as the LED current with SEL=HIGH divided by the LED current with SEL=LOW. In the AAT1239-1, the possible scaling factors are 3.0x to 1.5x with the internal default setting of 1.5x.



**Figure 6: AAT1239-1 SEL Pin Scaling Factor:  $I_{LED} (SEL = High)$  Divided by  $I_{LED} (SEL = Low)$ .**

### S²Cwire Serial Interface

AnalogicTech’s S²Cwire single wire serial interface is a proprietary high-speed single-wire interface available only from AnalogicTech. The S²Cwire interface records

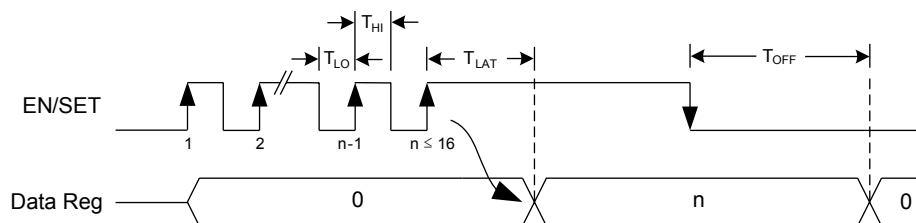
rising edges of the EN/SET input and decodes them into 16 individual states. Each state corresponds to a reference feedback voltage setting on the FB pin, as shown in Table 2.

### S²Cwire Serial Interface Timing

The S²Cwire single wire serial interface data can be clocked-in at speeds up to 1MHz. After data has been submitted, EN/SET is held high to latch the data for a period  $T_{LAT}$ . The FB pin voltage is subsequently changed to the level as defined by the state of the SEL logic pin. When EN/SET is set low for a time greater than  $T_{OFF}$ , the AAT1239-1 is disabled. When the AAT1239-1 is disabled, the register is reset to its default value. In the AAT1239-1, the FB pin voltage is set to 0.3V if the EN/SET pin is subsequently pulled HIGH.

### S²Cwire Feedback Voltage Programming

The FB pin voltage is set to the default level at initial powerup. The AAT1239-1 is programmed through the S²Cwire interface. Table 2 illustrates FB pin voltage programming for the AAT1239-1. The rising clock edges applied at the EN/SET pin determine the FB pin voltage. If a logic LOW is applied at the SEL pin of the AAT1239-1, the default feedback voltage range becomes 0.4V to 0.1V and 0.6V to 0.3V for a logic HIGH condition at the SEL pin.



**Figure 7: AAT1239-1 S²Cwire Timing Diagram to Program the Output Voltage.**

Rising Clock Edges/Data Register	SEL = Low		SEL = High	
	Reference Voltage (V)	LED Current (mA); $R_{BALLAST} = 30.1\Omega$	Reference Voltage (V)	LED Current (mA); $R_{BALLAST} = 30.1\Omega$
1	0.4 (default)	13.29	0.6 (default)	19.93
2	0.38	12.62	0.58	19.27
3	0.36	11.96	0.56	18.60
4	0.34	11.30	0.54	17.94
5	0.32	10.63	0.52	17.28
6	0.30	9.97	0.50	16.61
7	0.28	9.30	0.48	15.95
8	0.26	8.64	0.46	15.28
9	0.24	7.97	0.44	14.62
10	0.22	7.31	0.42	13.95
11	0.20	6.64	0.40	13.29
12	0.18	5.98	0.38	12.62
13	0.16	5.32	0.36	11.96
14	0.14	4.65	0.34	11.30
15	0.12	3.99	0.32	10.63
16	0.10	3.32	0.30	9.97

**Table 2: AAT1239-1 S<sup>2</sup>Cwire Reference Feedback Voltage Control Settings With  $R_{BALLAST} = 30.1\Omega$  (Assumes Nominal Values)\*.**

### Selecting the Schottky Diode

To ensure minimum forward voltage drop and no recovery, high voltage Schottky diodes are considered the best choice for the AAT1239-1 boost converter. The output diode is sized to maintain acceptable efficiency and reasonable operating junction temperature under full load operating conditions. Forward voltage ( $V_F$ ) and package thermal resistance ( $\theta_{JA}$ ) are the dominant factors to consider in selecting a diode. The diode non-repetitive peak forward surge current rating ( $I_{FSM}$ ) should be considered for high pulsed load applications, such as camera flash.  $I_{FSM}$  rating drops with increasing conduction period. Manufacturers' datasheets should be consulted to verify reliability under peak loading conditions. The diode's published current rating may not reflect actual operating conditions and should be used only as a comparative measure between similarly rated devices.

40V rated Schottky diodes are recommended for outputs less than 30V, while 60V rated Schottky diodes are recommended for outputs greater than 35V.

The switching period is divided between ON and OFF time intervals.

$$\frac{1}{F_S} = T_{ON} + T_{OFF}$$

During the ON time, the N-channel power MOSFET is conducting and storing energy in the boost inductor. During the OFF time, the N-channel power MOSFET is not conducting. Stored energy is transferred from the input battery and boost inductor to the output load through the output diode.

Duty cycle is defined as the ON time divided by the total switching interval.

$$D = \frac{T_{ON}}{T_{ON} + T_{OFF}}$$

$$= T_{ON} \cdot F_S$$

\*All table entries are preliminary and subject to change without notice.

The maximum duty cycle can be estimated from the relationship for a continuous mode boost converter. Maximum duty cycle ( $D_{MAX}$ ) is the duty cycle at minimum input voltage ( $V_{IN(MIN)}$ ).

$$D_{MAX} = \frac{V_{OUT} - V_{IN(MIN)}}{V_{OUT}}$$

The average diode current is equal to the output current.

$$I_{AVG(TOT)} = I_{OUT}$$

The average output current multiplied by the forward diode voltage determines the loss of the output diode.

$$\begin{aligned} P_{LOSS(DIODE)} &= I_{AVG(TOT)} \cdot V_F \\ &= I_{OUT} \cdot V_F \end{aligned}$$

For continuous LED currents, the diode junction temperature can be estimated.

$$T_{J(DIODE)} = T_{AMB} + \theta_{JA} \cdot P_{LOSS(DIODE)}$$

Output diode junction temperature should be maintained below 110°C, but may vary depending on application and/or system guidelines. The diode  $\theta_{JA}$  can be minimized with additional PCB area on the cathode. PCB heat-sinking the anode may degrade EMI performance. The reverse leakage current of the rectifier must be considered to maintain low quiescent (input) current and

high efficiency under light load. The rectifier reverse current increases dramatically at elevated temperatures.

### Selecting the Boost Inductor

The AAT1239-1 controller utilizes hysteretic control and the switching frequency varies with output load and input voltage. The value of the inductor determines the maximum switching frequency of the boost converter. Increased output inductance decreases the switching frequency and switching loss, but results in higher peak currents and increased output voltage ripple. To maintain 2MHz maximum switching frequency and stable operation, an output inductor sized from 1.5µH to 2.7µH is recommended. For higher efficiency in Li-ion battery applications ( $V_{IN}$  from 3.0V to 4.2V) and stable operation, increasing the inductor size up to 10µH is recommended. Figure 15 and 16 show the special enhanced efficiency application.

A better estimate of  $D_{MAX}$  is possible once  $V_F$  is known.

$$D_{MAX} = \frac{(V_{OUT} + V_F - V_{IN(MIN)})}{(V_{OUT} + V_F)}$$

Where  $V_F$  is the Schottky diode forward voltage. If not known, it can be estimated at 0.5V.

Manufacturer's specifications list both the inductor DC current rating, which is a thermal limitation, and peak inductor current rating, which is determined by the saturation characteristics. Measurements at full load and high ambient temperature should be completed to ensure that the inductor does not saturate or exhibit excessive temperature rise.

Manufacturer	Part Number	Rated Forward Current (A)	Non-Repetitive Peak Surge Current (A)	Rated Voltage (V)	Thermal Resistance ( $\theta_{JA}$ , °C/W)	Size (mm) (LxWxH)	Case
Taiwan Semiconductor Co., Ltd.	SS16L	1.1	30	60	45	3.8x1.9x1.43	Sub SMA
	SS15L		30	50	45	3.8x1.9x1.43	Sub SMA
	SS14L		30	40	45	3.8x1.9x1.43	Sub SMA
Diodes, Inc	B340LA	3	70.0	40	25	5.59x2.92x2.30	SMA
Zetex	ZHCS350	0.35	4.2	40	330	1.7x0.9x0.8	SOD523

**Table 3: Typical Surface Mount Schottky Rectifiers for Various Output Levels.**

The output inductor (L) is selected to avoid saturation at minimum input voltage, maximum output load conditions. Peak current may be estimated using the following equation, assuming continuous conduction mode. Worst-case peak current occurs at minimum input voltage (maximum duty cycle) and maximum load. Switching frequency ( $F_s$ ) can be estimated from the curves and assumes a 2.2µH inductor.

$$I_{PEAK} = \frac{I_{OUT}}{(1 - D_{MAX})} + \frac{D_{MAX} \cdot V_{IN(MIN)}}{(2 \cdot F_s \cdot L)}$$

At light load and low output voltage, the controller reduces the operating frequency to maintain maximum operating efficiency. As a result, further reduction in output load does not reduce the peak current. Minimum peak current can be estimated from 0.5A to 0.75A.

At high load and high output voltages, the switching frequency is somewhat diminished, resulting in higher  $I_{PEAK}$ . Bench measurements are recommended to confirm actual  $I_{PEAK}$  and ensure that the inductor does not saturate at maximum LED current and minimum input voltage.

The RMS current flowing through the boost inductor is equal to the DC plus AC ripple components. Under worst-case RMS conditions, the current waveform is critically continuous. The resulting RMS calculation yields worst-case inductor loss. The RMS current value should

be compared against the manufacturer's temperature rise, or thermal derating, guidelines.

$$I_{RMS} = \frac{I_{PEAK}}{\sqrt{3}}$$

For a given inductor type, smaller inductor size leads to an increase in DCR winding resistance and, in most cases, increased thermal impedance. Winding resistance degrades boost converter efficiency and increases the inductor's operating temperature.

$$P_{LOSS(INDUCTOR)} = I_{RMS}^2 \cdot DCR$$

To ensure high reliability, the inductor case temperature should not exceed 100°C. In some cases, PCB heatsinking applied to the LIN node (non-switching) can improve the inductor's thermal capability. PCB heatsinking may degrade EMI performance when applied to the SW node (switching) of the AAT1239-1.

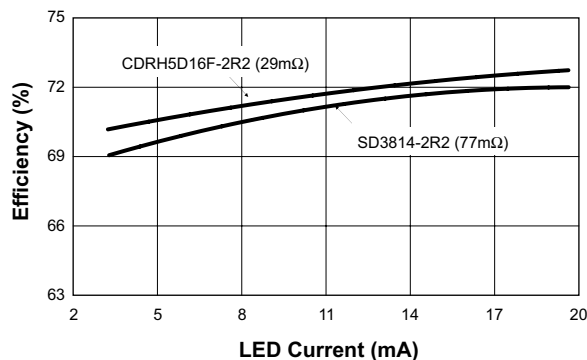
Shielded inductors provide decreased EMI and may be required in noise sensitive applications. Unshielded chip inductors provide significant space savings at a reduced cost compared to shielded (wound and gapped) inductors. In general, chip-type inductors have increased winding resistance (DCR) when compared to shielded, wound varieties.

Manufacturer	Part Number	Inductance (µH)	Maximum DC $I_{SAT}$ Current (mA)	DCR (mΩ)	Size (mm) LxWxH	Type
Sumida www.sumida.com	CDRH2D14-2R2	2.2	1500	75	3.2x3.2x1.55	Shielded
	CDRH2D14-4R7	4.7	1000	135	3.2x3.2x1.55	Shielded
	CDRH4D22/HP-4R7	4.7	2200	66	5.0x5.0x2.4	Shielded
	CDRH3D18-100NC	10	900	164	4.0x4.0x2.0	Shielded
Cooper Electronics www.cooperet.com	SD3814-2R2	2.2	1900	77	4.0x4.0x1.0	Shielded
	SD3110-2R2	2.2	910	161	3.1x3.1x1.0	Shielded
	SD3118-4R7	4.7	1020	162	3.1x3.1x1.8	Shielded
	SD3118-100	10	900	295	3.1x3.1x1.8	Shielded
Taiyo Yuden www.t-yuden.com	NP03SB-2R0M	2	1900	32	4.0x4.0x1.8	Shielded
	NR3010T-2R2M	2.2	1100	95	3.0x3.0x1.0	Shielded
	NP03SB4R7	4.7	1200	47	4.0x4.0x1.8	Shielded
	NP03SB100M	10	800	100	4.0x4.0x1.8	Shielded

**Table 4: Recommended Inductors for Various Output Levels (Select  $I_{PEAK} < I_{SAT}$ ).**

### Inductor Efficiency Considerations

The efficiency for different inductors is shown in Figure 8 for ten white LEDs in series. Smaller inductors yield increased DCR and reduced operating efficiency.



**Figure 8: AAT1239-1 Efficiency for Different Inductor Types ( $V_{IN} = 3.6V$ ; Ten White LEDs in Series).**

### Selecting the Boost Capacitors

The high output ripple inherent in the boost converter necessitates low impedance output filtering.

Multi-layer ceramic (MLC) capacitors provide small size and adequate capacitance, low parasitic equivalent series resistance (ESR) and equivalent series inductance (ESL), and are well suited for use with the AAT1239-1 boost regulator. MLC capacitors of type X7R or X5R are

recommended to ensure good capacitance stability over the full operating temperature range.

The output capacitor is sized to maintain the output load without significant voltage droop ( $\Delta V_{OUT}$ ) during the power switch ON interval, when the output diode is not conducting. A ceramic output capacitor from 2.2 $\mu F$  to 4.7 $\mu F$  is recommended (see Table 5). Typically, 50V rated capacitors are required for the 40V maximum boost output. Ceramic capacitors sized as small as 0805 or 1206 are available which meet these requirements.

MLC capacitors exhibit significant capacitance reduction with applied voltage. Output ripple measurements should confirm that output voltage droop and operating stability are acceptable. Voltage derating can minimize this factor, but results may vary with package size and among specific manufacturers.

Output capacitor size can be estimated at a switching frequency ( $F_S$ ) of 500kHz (worst case).

$$C_{OUT} = \frac{I_{OUT} \cdot D_{MAX}}{F_S \cdot \Delta V_{OUT}}$$

To maintain stable operation at full load, the output capacitor should be sized to maintain  $\Delta V_{OUT}$  between 100mV and 200mV.

The boost converter input current flows during both ON and OFF switching intervals. The input ripple current is less than the output ripple and, as a result, less input capacitance is required.

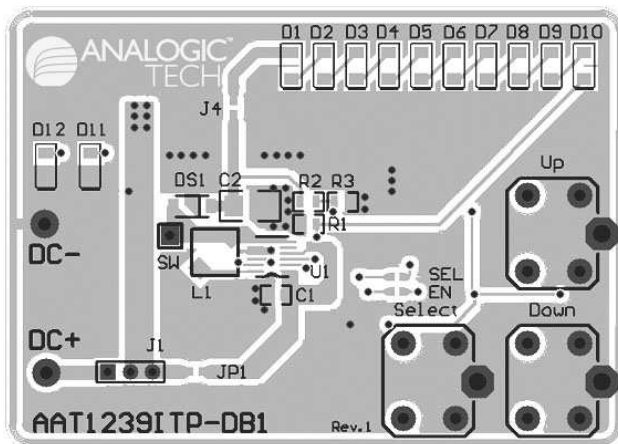
Manufacturer	Part Number	Value ( $\mu F$ )	Voltage Rating	Temp Co	Case Size
Murata	GRM188R60J225KE19	2.2	6.3	X5R	0603
Murata	GRM188R61A225KE34	2.2	10	X5R	0603
Murata	GRM21BR71E225KA73L	2.2	25	X7R	0805
Murata	GRM31CR71H225KA88	2.2	50	X7R	1206
Murata	GRM31CR71H475K	4.7	50	X7R	1206

**Table 5: Recommended Ceramic Capacitors.**

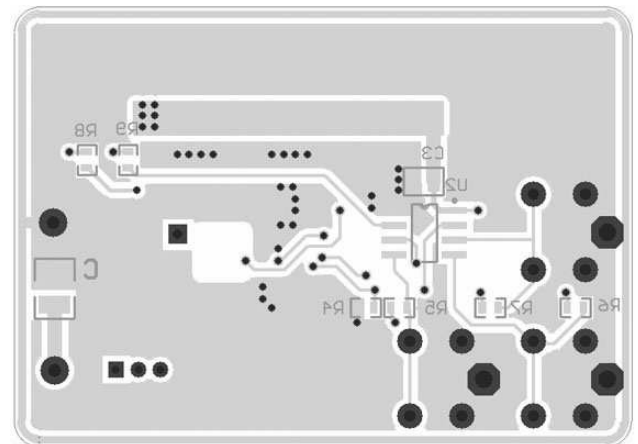
### PCB Layout Guidelines

Boost converter performance can be adversely affected by poor layout. Possible impact includes high input and output voltage ripple, poor EMI performance, and reduced operating efficiency. Every attempt should be made to optimize the layout in order to minimize parasitic PCB effects (stray resistance, capacitance, and inductance) and EMI coupling from the high frequency SW node. A suggested PCB layout for the AAT1239-1 boost converter is shown in Figures 9 and 10. The following PCB layout guidelines should be considered:

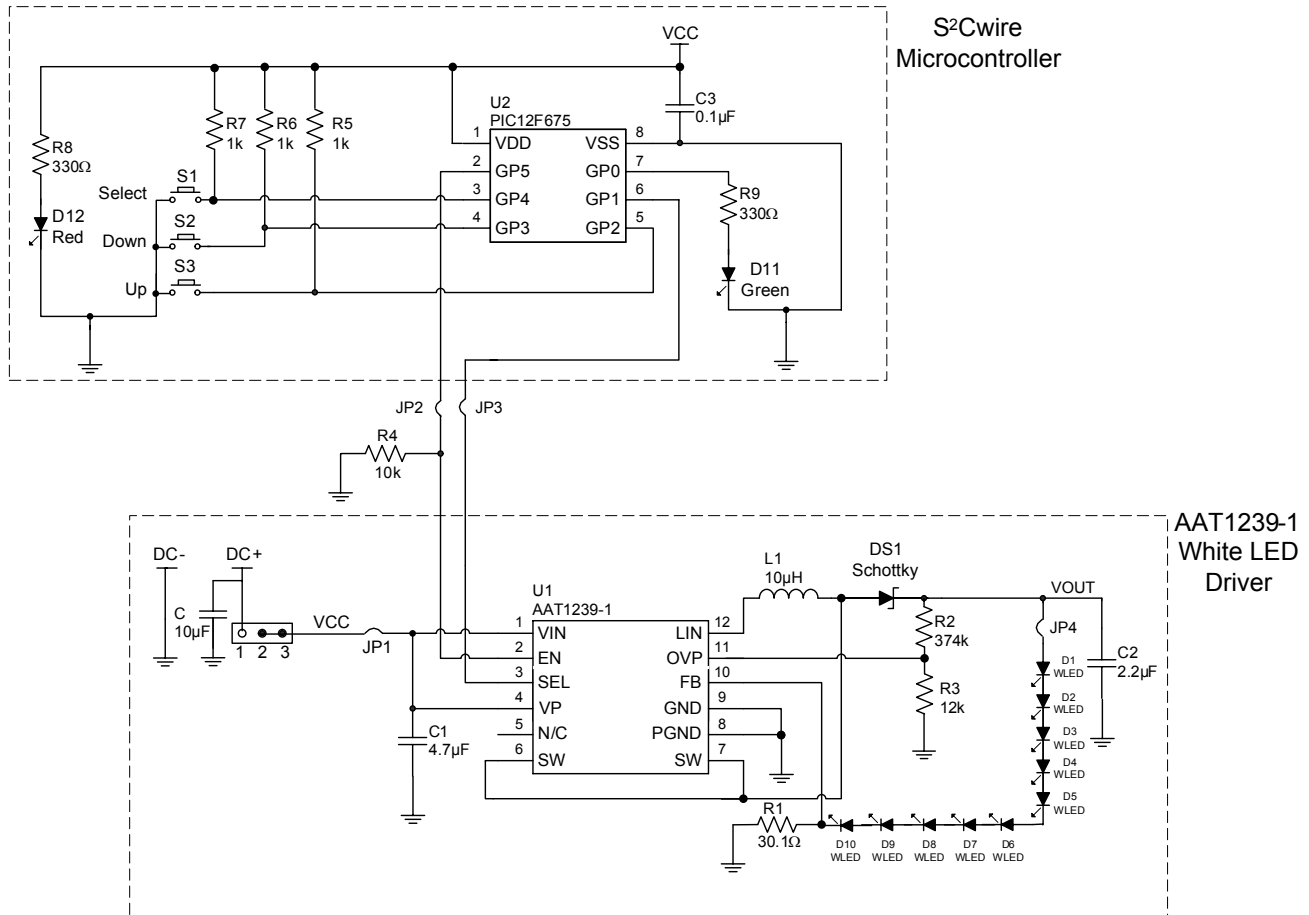
1. Minimize the distance from Capacitor C1 and C2 negative terminal to the PGND pins. This is especially true with output capacitor C2, which conducts high ripple current from the output diode back to the PGND pins.
2. Minimize the distance between L1 to DS1 and switching pin SW; minimize the size of the PCB area connected to the SW pin.
3. Maintain a ground plane and connect to the IC PGND pin(s) as well as the GND terminals of C1 and C2.
4. Consider additional PCB area on DS1 cathode to maximize heatsinking capability. This may be necessary when using a diode with a high  $V_F$  and/or thermal resistance.
5. To avoid problems at startup, add a 10k $\Omega$  resistor between the VIN, VP and EN/SET pins (R4). This is critical in applications requiring immunity from input noise during "hot plug" events, e.g. when plugged into an active USB port.



**Figure 9: AAT1239-1 Evaluation Board Top Side Layout (with ten LEDs and microcontroller).**

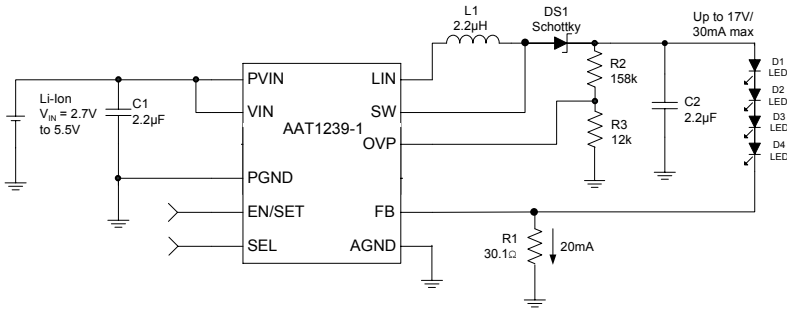


**Figure 10: AAT1239-1 Evaluation Board Bottom Side Layout (with ten LEDs and microcontroller).**



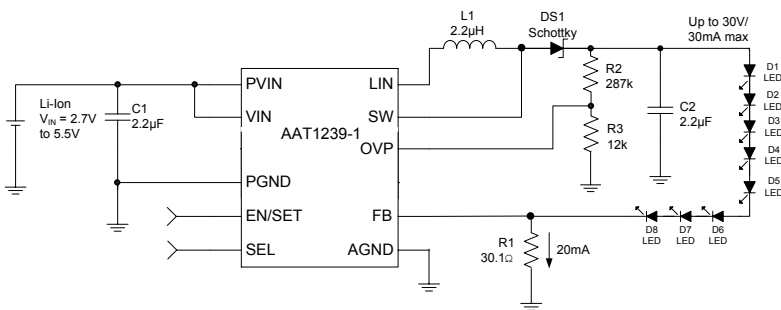
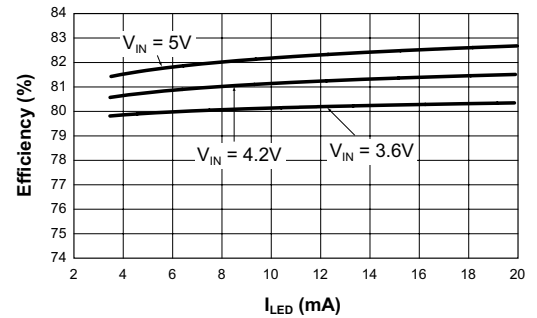
**Figure 11: AAT1239-1 Evaluation Board Schematic (with ten LEDs and microcontroller).**

**Additional Applications**



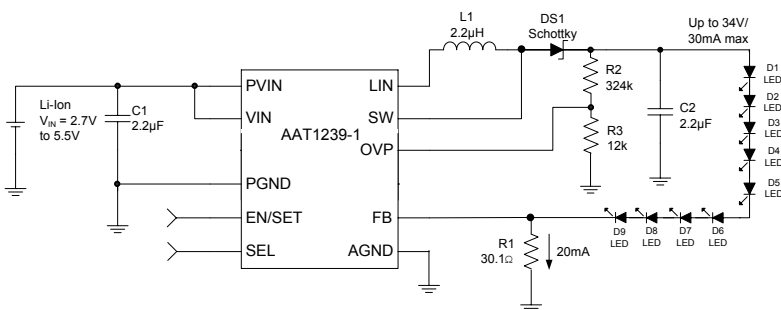
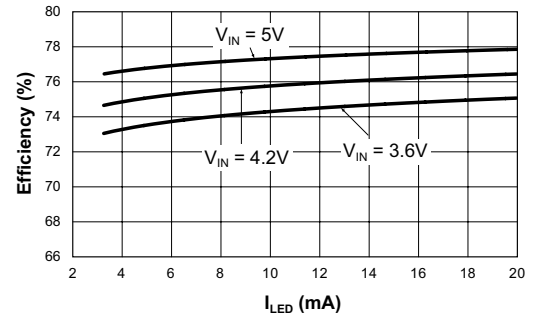
**Figure 12: Four LEDs In Series Configuration.**

**Efficiency vs. LED Current**  
(4 White LEDs;  $R_{BALLAST} = 30.1\Omega$ )



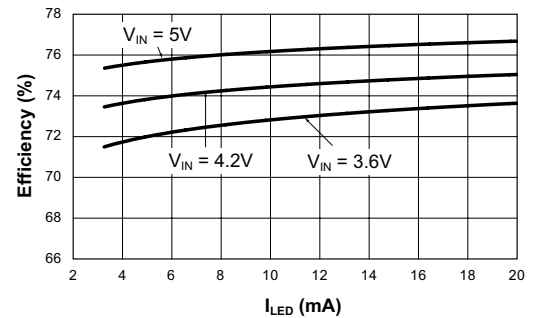
**Figure 13: Eight LEDs In Series Configuration.**

**Efficiency vs. LED Current**  
(8 White LEDs;  $R_{BALLAST} = 30.1\Omega$ )



**Figure 14: Nine LEDs In Series Configuration.**

**Efficiency vs. LED Current**  
(9 White LEDs;  $R_{BALLAST} = 30.1\Omega$ )



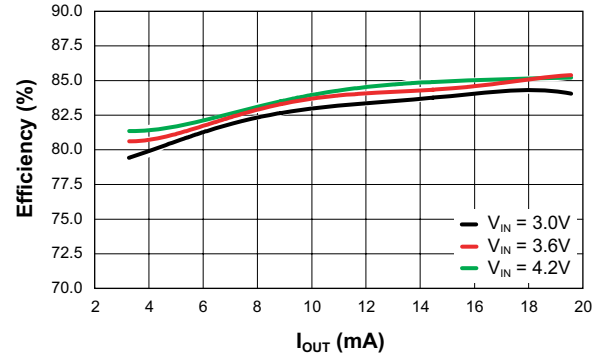
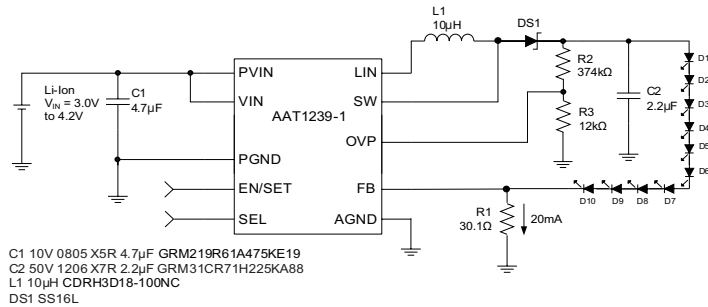


Figure 15: Enhanced Efficiency Configuration for Li-ion Battery Ten WLEDs Series-Connected Application.

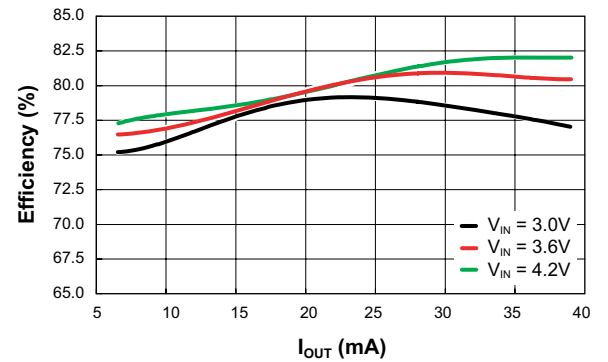
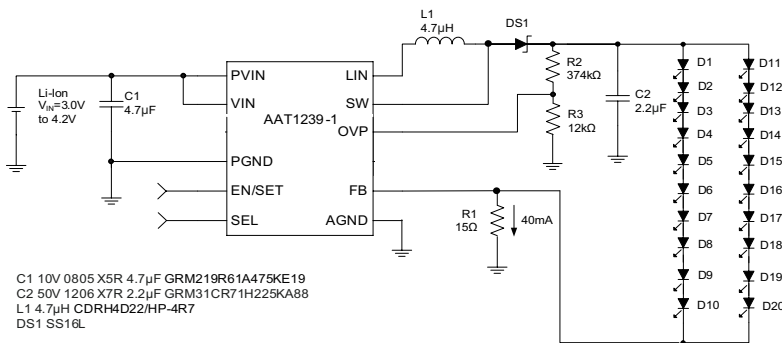


Figure 16: Enhanced Efficiency Configuration for Li-ion Battery, Two Branch, Ten WLEDs Series-Connected Application.

### Ordering Information

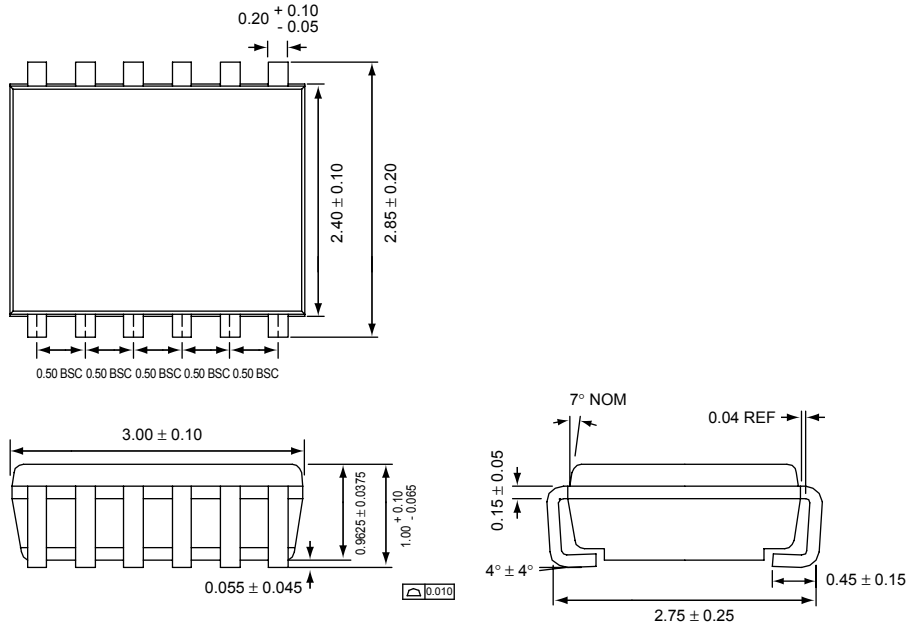
Package	Marking <sup>1</sup>	Part Number (Tape and Reel) <sup>2</sup>
TSOPJW-12	ZLXYY	<b>AAT1239ITP-1-T1</b>



All AnalogicTech products are offered in Pb-free packaging. The term “Pb-free” means semiconductor products that are in compliance with current RoHS standards, including the requirement that lead not exceed 0.1% by weight in homogeneous materials. For more information, please visit our website at <http://www.analogictech.com/aboutus/quality.php>.

### Package Information

#### TSOPJW-12



All dimensions in millimeters.

1. XYY = assembly and date code.
2. Sample stock is generally held on part numbers listed in **BOLD**.

**Advanced Analogic Technologies, Inc.**  
 3230 Scott Boulevard, Santa Clara, CA 95054  
 Phone (408) 737-4600  
 Fax (408) 737-4611



© Advanced Analogic Technologies, Inc. AnalogicTech cannot assume responsibility for use of any circuitry other than circuitry entirely embodied in an AnalogicTech product. No circuit patent licenses, copyrights, mask work rights, or other intellectual property rights are implied. AnalogicTech reserves the right to make changes to their products or specifications or to discontinue any product or service without notice. Except as provided in AnalogicTech's terms and conditions of sale, AnalogicTech assumes no liability whatsoever, and AnalogicTech disclaims any express or implied warranty relating to the sale and/or use of AnalogicTech products including liability or warranties relating to fitness for a particular purpose, merchantability, or infringement of any patent, copyright or other intellectual property right. In order to minimize risks associated with the customer's applications, adequate design and operating safeguards must be provided by the customer to minimize inherent or procedural hazards. Testing and other quality control techniques are utilized to the extent AnalogicTech deems necessary to support this warranty. Specific testing of all parameters of each device is not necessarily performed. AnalogicTech and the AnalogicTech logo are trademarks of Advanced Analogic Technologies Incorporated. All other brand and product names appearing in this document are registered trademarks or trademarks of their respective holders.