



FEATURES

- 90~264 VAC Input, Soft Start
- 0.98 Active Power Factor
- 87% to 91% Efficiency
- High Peak Power
- Low Safety Ground Leakage Current
- Class I & Class II Models Available
- CEC & Energy Star Level V Compliance



INPUT SPECIFICATIONS

Input Voltage Range	90~264 VAC
Input Frequency	47~63Hz
Input Current	1.60A rms @ 115 VAC
	0.80A rms @ 230 VAC
Inrush Current	80A @ 115 VAC or 160A @ 230 VAC,
	at 25°C cold start
Soft Start	Yes
Earth Leakage Current	200µA max. @ 264 VAC, 63Hz
Touch Current	100µA max. @ 264 VAC, 63Hz

OUTPUT SPECIFICATIONS

Output Power Ratings	See table
Minimum Load	Not required
Tolerance	±5%
Ripple and Noise*	1% peak to peak max. at full load
Overvoltage Protection	Set at 115-140% of its nominal
	output voltage
Overcurrent Protection	Protected to short-circuit
	conditions
Temperature Coefficient	±0.04%/°C max.
Transient Response	Max. excursion of 4% or better on
	all models, recovering to 1% of
	final value within 500 us after a
	25% step load change

* Measured with 20MHz bandwidth at rated line voltage and output load ranges, with a 10µF tantalum capacitor in parallel with a 0.1µF ceramic capacitor in parallel across the output.

GENERAL SPECIFICATIONS

Power Factor	0.98 typical @ 115 VAC
Efficiency	87% minimum at full load
Hold-up Time	15ms at 110 VAC
Switching Frequency	90~160KHz
Operating Temperature	0°C to +60°C
Derating	Derate from 100% at +40°C linearly
	to 50% at +60°C
Storage Temperature	-40°C to +85°C
Relative Humidity	5°C to +95°C non-condensing
Withstand Voltage	4000 VAC from input to output
	1500 VAC from input to ground
	500 VAC from output to ground
MTBF	150K hours minimum at full load,
	25°C ambient, calculated per
	MIL-HDBK-217F

MODELS LIST

Product No. ⁽¹⁾	Output Voltage	Maximum Current	Peak ⁽²⁾ Current	Maximum Power
TMP135-12	12V	10.0A	20.0A	120W
TMP135-13	13V	9.23A	18.5A	120W
TMP135-15	14~16V	9.29A	18.6A	130W
TMP135-18	18~19V	7.50A	15.0A	135W
TMP135-20	20~21V	6.75A	13.5A	135W
TMP135-24	24~25V	5.63A	11.3A	135W
TMP135-28	28~29V	4.83A	5.8A	135W
TMP135-30	30~32V	4.50A	5.4A	135W
TMP135-36	36~38V	3.75A	4.5A	135W
TMP135-48	46~50V	2.94A	3.5A	135W

Notes:

- 1) The listed P/N's are for Class I models equipped with IEC 320/C14 AC inlet. Add suffix "C2" to order Class II models equipped with IEC 320/C18 AC inlet. When ordering 14-50V output units, specify the requested voltage, e.g. use P/N TMP135-18.5-C2 to order 18.5V Class II model.
- 2) The peak current is for 10 seconds maximum with the average power not over the maximum power.

STANDARDS & COMPLIANCES

EN 55011, EN 55022	Class B, conducted & radiated
FCC, VCCI	Class B, conducted & radiated
EN 61000-3-2	Harmonic distortion, Class A & D
EN 61000-3-3	Line flicker
EN 61000-4-2	ESD, ±8 KV air and ±6 KV contact
EN 61000-4-3	Radiated immunity, 3V/m
EN 61000-4-4	Fast transient/burst, ±2 KV
EN 61000-4-5	Surge, ±1 KV diff., ±2 KV com.
EN 61000-4-6	Conducted immunity, 3 Vrms
EN 61000-4-8	Magnetic field immunity, 3A/m
EN 61000-4-11	Voltage dip immunity,
	30% reduction for 500ms,
	60% reduction for 100ms,
	>95% reduction for 10ms
Safety Standards	UL/IEC/EN 60601-1 (3 rd Edition),
	ANSI/AAMI ES 60601-1 (1 st Edition),
	CSA C22.2 No. 60601-1 (2 nd Edition),
	IEC/EN 60950-1 (2 nd Edition)
Agency Approvals	UL, cUL, TUV, CE, CB
Other Compliances	RoHS, CEC & Energy Star Level V

* Class I models certified to medical and ITE safety standards; Class II models certified to medical standard only.

TMP135 Series

120-135 Watts Medical & ITE Power Adapters

MECHANICAL SPECIFICATIONS

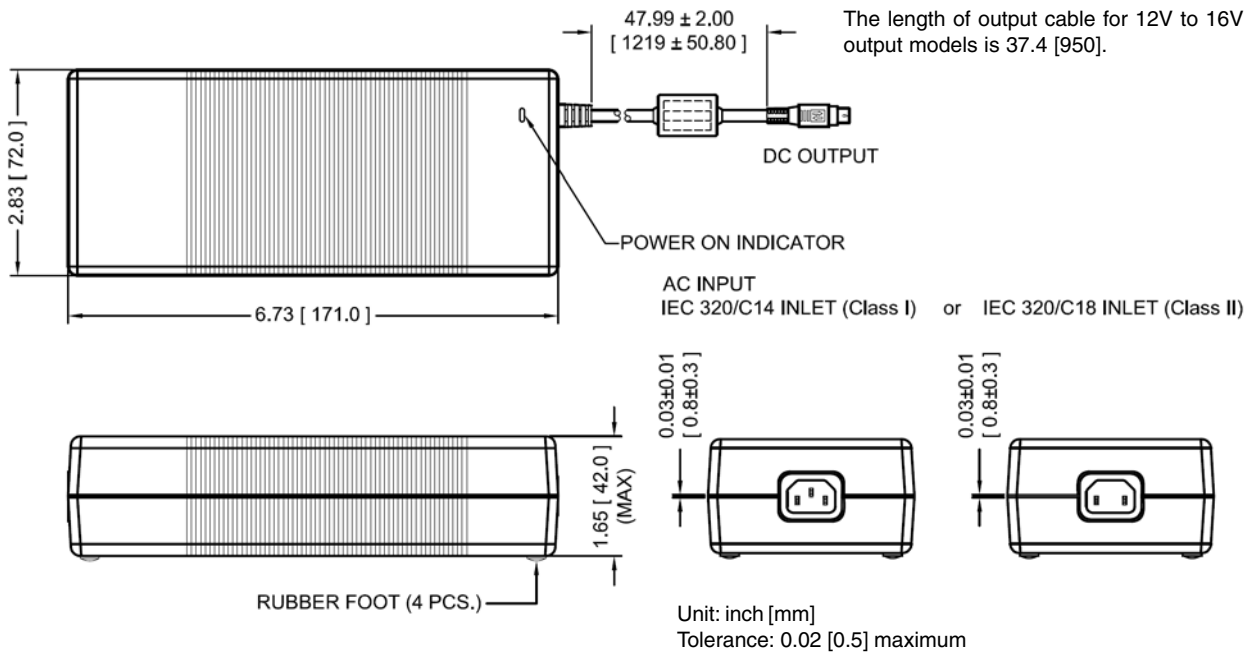

DC OUTPUT CONNECTOR	
PIN	FUNCTION
1	RETURN
2	+V
3	RETURN
4	+V
SHELL	AC GND/*NC
*Shell is NC on class II models	

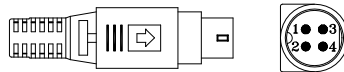

Output connector: Kycon P/N KPPX-4P 4-pin circular DIN or equivalent.
Mating connector: Kycon P/N KPJX-4S-S or equivalent
Contact TRUMPower for output connector options.