

500MHz Triple, Multiplexing Amplifiers

The EL4340, EL4342 are fixed unity gain mux amps featuring high slew rates and excellent bandwidth for video switching. These devices feature a high impedance output state (HIZ) that enables the outputs of multiple devices to be wired together. A power-down mode ($\overline{\text{ENABLE}}$) is included to turn off un-needed circuitry in power sensitive applications. The $\overline{\text{ENABLE}}$ pin, when pulled high, sets the EL4340, EL4342 into standby power mode - consuming just 18mW. An added feature in the EL4340 is a latch enable function ($\overline{\text{LE}}$) that allows independent logic control using a common logic bus.

Ordering Information

| PART NUMBER (Notes 1, 2, 3) | PART MARKING | PACKAGE (Pb-Free) | PKG. DWG. # |
|--------------------------------|------------------|----------------------|-------------|
| EL4340IUZ | EL4340IUZ | 24 Ld QSOP | MDP0040 |
| EL4342ILZA | 4342ILZ | 32 Ld 5x6 QFN | L32.5x6A |
| EL4340IUZ-EVAL | Evaluation Board | | |
| EL4342ILZA-EVAL | Evaluation Board | | |

NOTES:

1. Add "-T13" or "-T7" suffix for tape and reel. Please refer to [TB347](#) for details on reel specifications.
2. These Intersil Pb-free plastic packaged products employ special Pb-free material sets, molding compounds/die attach materials, and 100% matte tin plate plus anneal (e3 termination finish, which is RoHS compliant and compatible with both SnPb and Pb-free soldering operations). Intersil Pb-free products are MSL classified at Pb-free peak reflow temperatures that meet or exceed the Pb-free requirements of IPC/JEDEC J STD-020.
3. For Moisture Sensitivity Level (MSL), please see device information page for [EL4340](#), [EL4342](#). For more information on MSL please see techbrief [TB363](#).

Related Literature

- AN1182, EL4340EVAL1 Evaluation Board User's Guide
- AN1193, ISL59445/EL4342E1 Evaluation Board User's Guide

Features

- Triple 2:1 and 4:1 multiplexers for RGB
- Internally set gain-of-1
- High speed three-state outputs (HIZ)
- Power-down mode ($\overline{\text{ENABLE}}$)
- Latch enable (EL4340)
- $\pm 5\text{V}$ operation
- $\pm 870 \text{ V}/\mu\text{s}$ slew rate
- 500MHz bandwidth
- Typical supply currents 10mA/ch (EL4340) and 15.3mA/ch (EL4342)
- Pb-free (RoHS compliant)

Applications

- HDTV/DTV analog inputs
- Video projectors
- Computer monitors
- Set-top boxes
- Security video
- Broadcast video equipment

TABLE 1. CHANNEL SELECT LOGIC TABLE EL4340

| S0 | $\overline{\text{ENABLE}}$ | HIZ | $\overline{\text{LE}}$ | OUTPUT |
|----|----------------------------|-----|------------------------|-------------------------|
| 0 | 0 | 0 | 0 | INO (A, B, C) |
| 1 | 0 | 0 | 0 | IN1 (A, B, C) |
| X | 1 | X | X | Power-down |
| X | 0 | 1 | X | High Z |
| X | 0 | 0 | 1 | Last S0 State Preserved |

TABLE 2. CHANNEL SELECT LOGIC TABLE EL4342

| S1 | S0 | $\overline{\text{ENABLE}}$ | HIZ | OUTPUT |
|----|----|----------------------------|-----|---------------|
| 0 | 0 | 0 | 0 | IN0 (A, B, C) |
| 0 | 1 | 0 | 0 | IN1 (A, B, C) |
| 1 | 0 | 0 | 0 | IN2 (A, B, C) |
| 1 | 1 | 0 | 0 | IN3 (A, B, C) |
| X | X | 1 | X | Power-down |
| X | X | 0 | 1 | High Z |

Pinouts

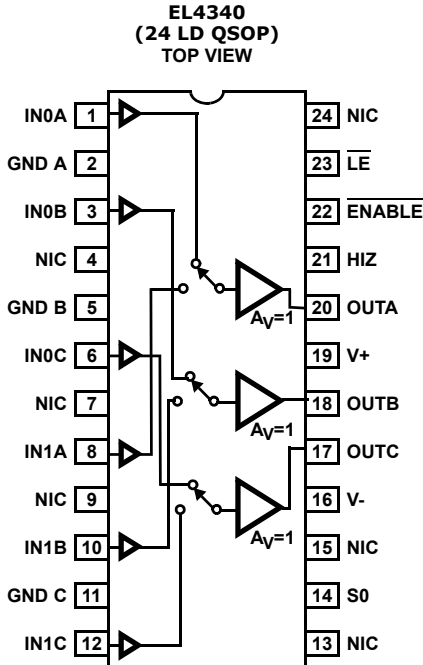

LATCHED ON HIGH LE
NIC = NO INTERNAL CONNECTION

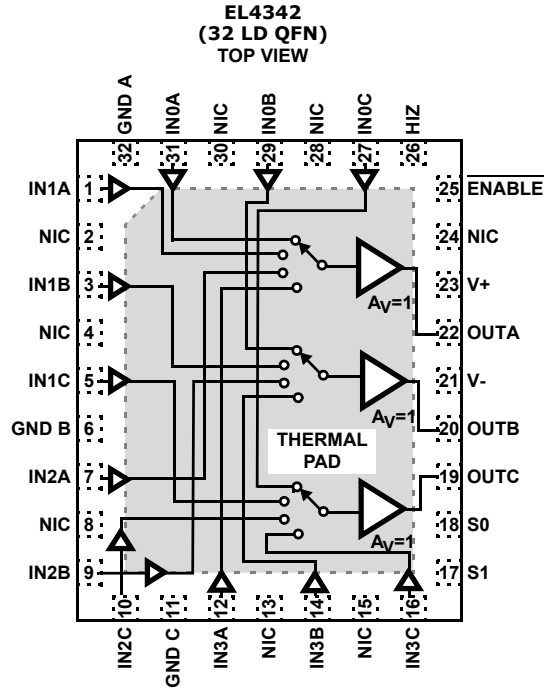

THERMAL PAD INTERNALLY CONNECTED TO V-.
PAD MUST BE TIED TO V-
NIC = NO INTERNAL CONNECTION

Functional Diagram EL4340

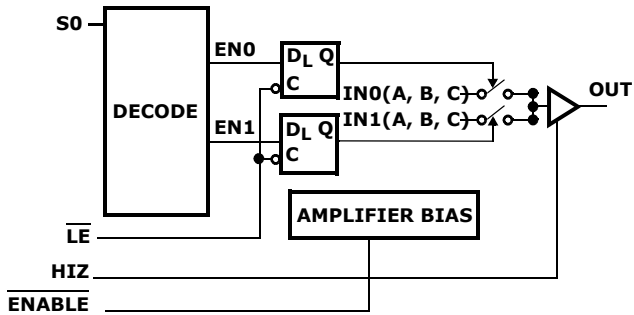

A LOGIC HIGH ON LE WILL LATCH THE LAST S0 STATE.
THIS LOGIC STATE IS PRESERVED WHEN CYCLING HIZ OR ENABLE FUNCTIONS.

Functional Diagram EL4342

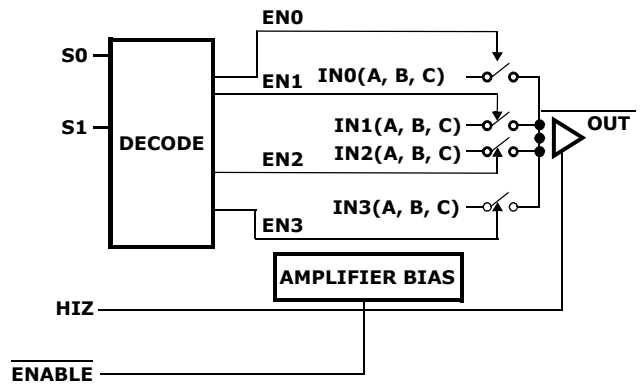

EL4340, EL4342

Absolute Maximum Ratings (T_A = +25°C)

| | |
|--------------------------------------------------|--------------------|
| Supply Voltage (V+ to V-) | 11V |
| Input Voltage | V- -0.5V, V+ +0.5V |
| Supply Turn-on Slew Rate | 1V/μs |
| Digital & Analog Input Current (Note 6) | 50mA |
| Output Current (Continuous) | 50mA |
| ESD Rating | |
| Human Body Model (Per MIL-STD-883 Method 3015.7) | 2500V |
| Machine Model | 300V |

Thermal Information

| | | |
|--------------------------------|-----------------------------------------------------------------------------------------------------------------|------------------------|
| Thermal Resistance (Typical) | θ _{JA} (°C/W) | θ _{JC} (°C/W) |
| 32 Ld QFN Package (Notes 4, 5) | 35 | 1.3 to 8 |
| 24 Ld QSOP Package (Note 4) | 88 | N/A |
| Storage Temperature Range | -65°C to +150°C | |
| Ambient Operating Temperature | -40°C to +85°C | |
| Operating Junction Temperature | -40°C to +125°C | |
| Power Dissipation | See Curves | |
| Pb-free reflow profile | see link below | |
| | http://www.intersil.com/pbfree/Pb-FreeReflow.asp | |

CAUTION: Do not operate at or near the maximum ratings listed for extended periods of time. Exposure to such conditions may adversely impact product reliability and result in failures not covered by warranty.

NOTES:

- θ_{JA} is measured in free air with the component mounted on a high effective thermal conductivity test board with “direct attach” features. See Tech Brief [TB379](#).
- For θ_{JC}, the “case temp” location is the center of the exposed metal pad on the package underside.
- If an input signal is applied before the supplies are powered up, the input current must be limited to these maximum values.

IMPORTANT NOTE: All parameters having Min/Max specifications are guaranteed. Typical values are for information purposes only. Unless otherwise noted, all tests are at the specified temperature and are pulsed tests, therefore: T_J = T_C = T_A

Electrical Specifications V+ = +5V, V- = -5V, GND = 0V, T_A = +25°C, Input Video = 1V_{P-P} and R_L = 500Ω to GND, C_L = 5pF unless otherwise specified.

| PARAMETER | DESCRIPTION | CONDITIONS | MIN | TYP | MAX | UNIT |
|-----------------------------------|------------------------------------|----------------------------------------------------------------|------|------|-------|------|
| GENERAL | | | | | | |
| +I _S Enabled | Enabled Supply Current (EL4340) | No load, V _{IN} = 0V, $\overline{\text{Enable}}$ Low | 26 | 30 | 34 | mA |
| | Enabled Supply Current (EL4342) | | 39 | 46 | 50 | mA |
| -I _S Enabled | Enabled Supply Current (EL4340) | No load, V _{IN} = 0V, $\overline{\text{Enable}}$ Low | -32 | -30 | -24 | mA |
| | Enabled Supply Current (EL4342) | | -48 | -46 | -36.5 | mA |
| +I _S Disabled | Disabled Supply Current (EL4340) | No load, V _{IN} = 0V, $\overline{\text{Enable}}$ High | 2.3 | 2.8 | 3.3 | mA |
| | Disabled Supply Current (EL4342) | No load, V _{IN} = 0V, $\overline{\text{Enable}}$ High | 3 | 3.5 | 4 | mA |
| -I _S Disabled | Disabled Supply Current | No load, V _{IN} = 0V, $\overline{\text{Enable}}$ High | | 10 | 100 | μA |
| V _{OUT} | Positive and Negative Output Swing | V _{IN} = ±3.5V, R _L = 500Ω | ±3.1 | ±3.4 | | V |
| I _{OUT} | Output Current | R _L = 10Ω to GND | ±80 | ±135 | | mA |
| V _{OS} | Output Offset Voltage (EL4340) | | -15 | 7 | +15 | mV |
| V _{OS} | Output Offset Voltage (EL4342) | | -10 | | +10 | mV |
| I _b | Input Bias Current | V _{IN} = 0V | -1 | -2 | -3 | μA |
| R _{OUT} | HIZ Output Resistance | HIZ = Logic High | | 1.4 | | MΩ |
| R _{OUT} | Enabled Output Resistance | HIZ = Logic Low | | 0.2 | | Ω |
| R _{IN} | Input Resistance | V _{IN} = ±3.5V | | 10 | | MΩ |
| A _{CL} or A _V | Voltage Gain | V _{IN} = ±1.5V, R _L = 500Ω | 0.98 | 0.99 | 1.02 | V/V |
| I _{TRI} | Output Current in Three-state | V _{OUT} = 0V | 8 | 15 | 22 | μA |
| LOGIC | | | | | | |
| V _{IH} | Input High Voltage (Logic Inputs) | | 2 | | | V |
| V _{IL} | Input Low Voltage (Logic Inputs) | | | | 0.8 | V |
| I _{IH} | Input High Current (Logic Inputs) | V _H = 5V | 215 | 270 | 320 | μA |
| I _{IL} | Input Low Current (Logic Inputs) | V _L = 0V | | 2 | 3 | μA |

EL4340, EL4342

Electrical Specifications $V_+ = +5V$, $V_- = -5V$, $GND = 0V$, $T_A = +25^\circ C$, Input Video = $1V_{P-P}$ and $R_L = 500\Omega$ to GND, $C_L = 5pF$ unless otherwise specified. (Continued)

| PARAMETER | DESCRIPTION | CONDITIONS | MIN | TYP | MAX | UNIT |
|----------------------------------|--------------------------------------|--------------------------------------------------------------|-----|-----------|-----|-------------|
| AC GENERAL | | | | | | |
| t_S | 0.1% Settling Time | Step = 1V | | 10 | | ns |
| PSRR (EL4340) | Power Supply Rejection Ratio | DC, PSRR V_+ and V_- combined | 52 | 72 | | dB |
| PSRR (EL4342) | Power Supply Rejection Ratio | DC, PSRR V_+ and V_- combined | 52 | 56 | | dB |
| ISO | Channel Isolation | $f = 10MHz$, Ch-Ch X-Talk and Off-Isolation, $C_L = 1.5pF$ | | 75 | | dB |
| dG | Differential Gain Error | NTC-7, $R_L = 150$, $C_L = 1.5pF$ | | 0.02 | | % |
| dP | Differential Phase Error | NTC-7, $R_L = 150$, $C_L = 1.5pF$ | | 0.02 | | ° |
| BW | -3dB Bandwidth | $C_L = 1.5pF$ | | 500 | | MHz |
| FBW | 0.1dB Bandwidth | $C_L = 1.5pF$ | | 60 | | MHz |
| | 0.1dB Bandwidth | $C_L = 4.7pF$ | | 120 | | MHz |
| SR | Slew Rate | 25% to 75%, $R_L = 150\Omega$, Input Enabled, $C_L = 1.5pF$ | | ± 870 | | V/ μs |
| SWITCHING CHARACTERISTICS | | | | | | |
| V_{GLITCH} EL4340 | Channel-to-Channel Switching Glitch | $V_{IN} = 0V$, $C_L = 1.5pF$ | | 40 | | mV $_{P-P}$ |
| | Enable Switching Glitch | $V_{IN} = 0V$, $C_L = 1.5pF$ | | 300 | | mV $_{P-P}$ |
| | HIZ Switching Glitch | $V_{IN} = 0V$, $C_L = 1.5pF$ | | 200 | | mV $_{P-P}$ |
| V_{GLITCH} EL4342 | Channel-to-Channel Switching Glitch | $V_{IN} = 0V$, $C_L = 1.5pF$ | | 20 | | mV $_{P-P}$ |
| | Enable Switching Glitch | $V_{IN} = 0V$, $C_L = 1.5pF$ | | 200 | | mV $_{P-P}$ |
| | HIZ Switching Glitch | $V_{IN} = 0V$, $C_L = 1.5pF$ | | 200 | | mV $_{P-P}$ |
| t_{SW-L-H} | Channel Switching Time Low to High | 1.2V logic threshold to 10% movement of analog output | | 18 | | ns |
| t_{SW-H-L} | Channel Switching Time High to Low | 1.2V logic threshold to 10% movement of analog output | | 20 | | ns |
| t_r, t_f | Rise and Fall Time | 10% to 90% | | 1.1 | | ns |
| tpd | Propagation Delay | 10% to 10% | | 0.9 | | ns |
| t_{LH} | Latch Enable Hold time (EL4340 only) | $\overline{LE} = 0$ | | 10 | | ns |

Typical Performance Curves $V_S = \pm 5V$, $R_L = 500\Omega$ to GND, $T_A = +25^\circ C$, unless otherwise specified.

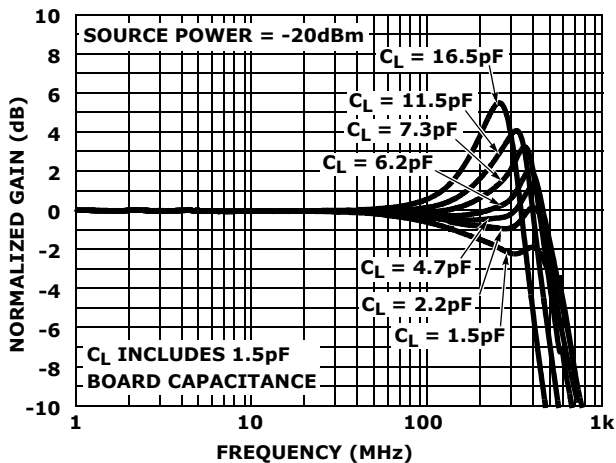

FIGURE 1. GAIN vs FREQUENCY VS C_L

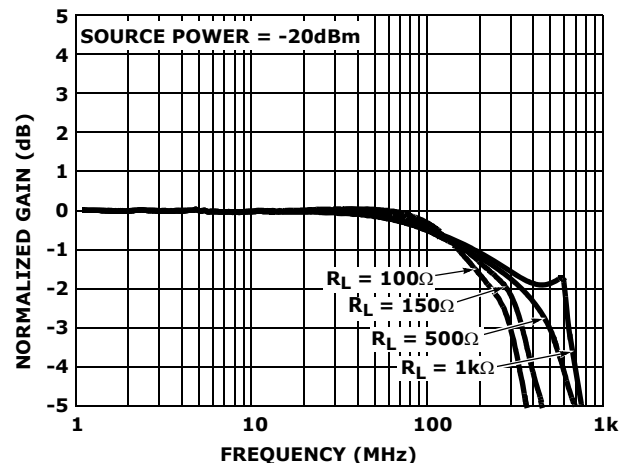

FIGURE 2. GAIN vs FREQUENCY VS R_L

Typical Performance Curves $V_S = \pm 5V$, $R_L = 500\Omega$ to GND, $T_A = +25^\circ C$, unless otherwise specified. (Continued)

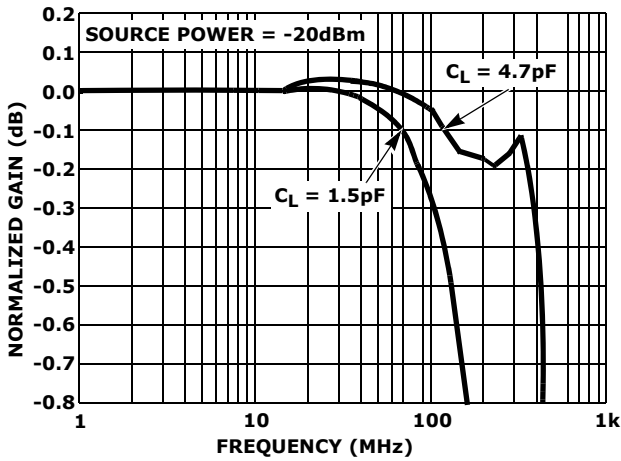

FIGURE 3. 0.1DB GAIN vs FREQUENCY

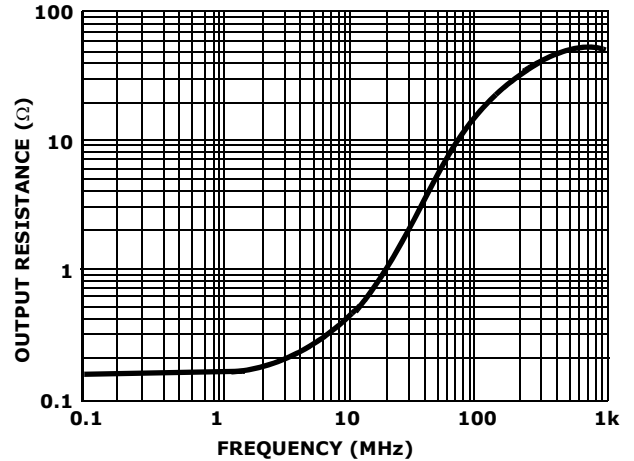

FIGURE 4. R_{OUT} vs FREQUENCY

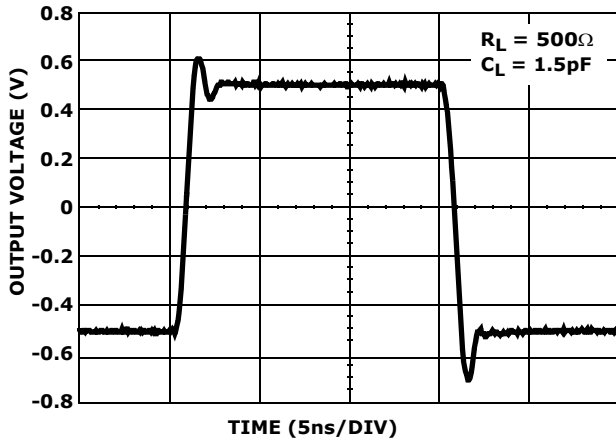

FIGURE 5. EL4340 TRANSIENT RESPONSE

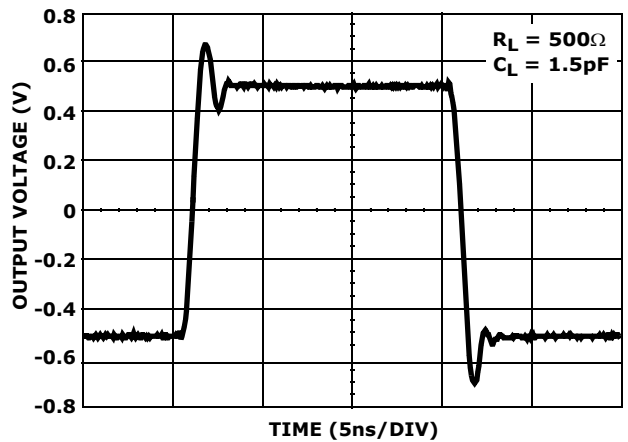

FIGURE 6. EL4342 TRANSIENT RESPONSE

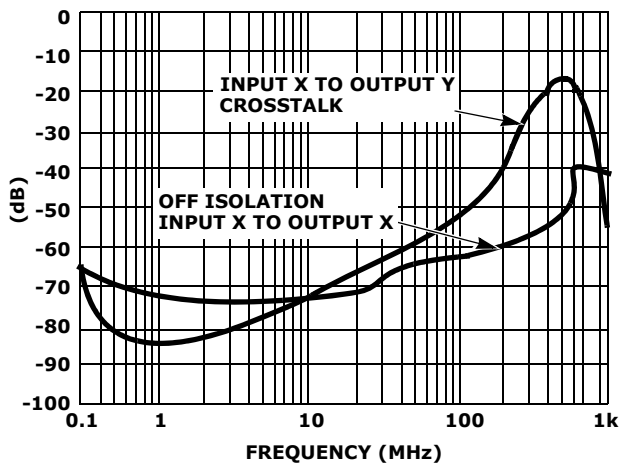

FIGURE 7. EL4340 CROSSTALK AND OFF-ISOLATION

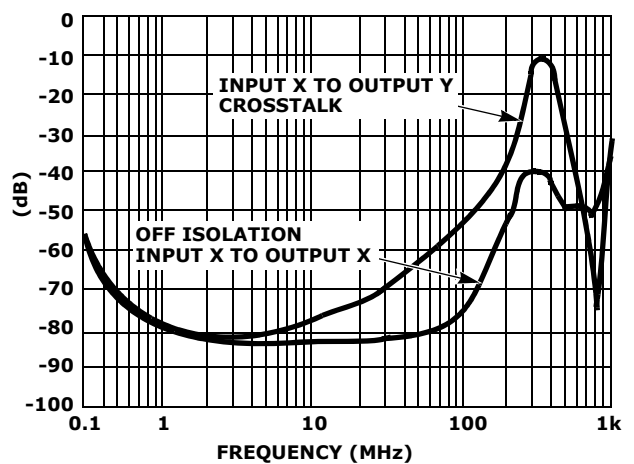

FIGURE 8. EL4342 CROSSTALK AND OFF-ISOLATION

Typical Performance Curves $V_S = \pm 5V$, $R_L = 500\Omega$ to GND, $T_A = +25^\circ C$, unless otherwise specified. (Continued)

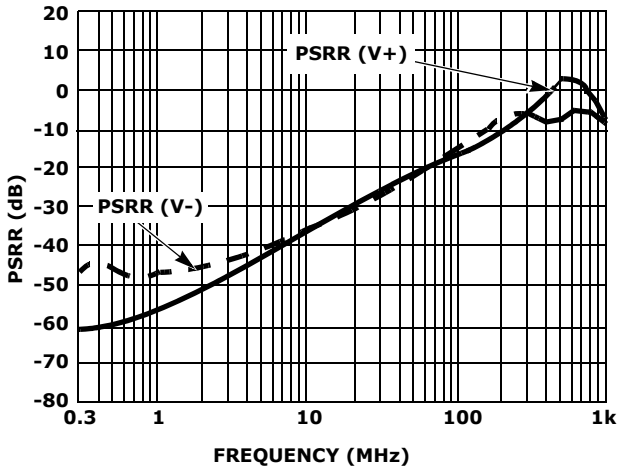

FIGURE 9. EL4340 PSRR CHANNELS A, B, C

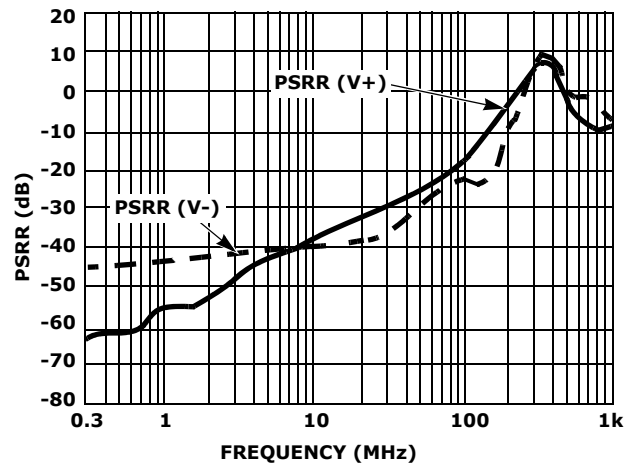

FIGURE 10. EL4342 PSRR CHANNELS A, B, C

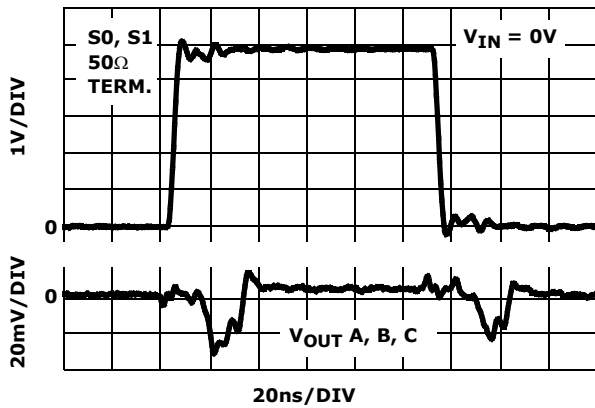

FIGURE 11. CHANNEL TO CHANNEL SWITCHING GLITCH $V_{IN} = 0V$

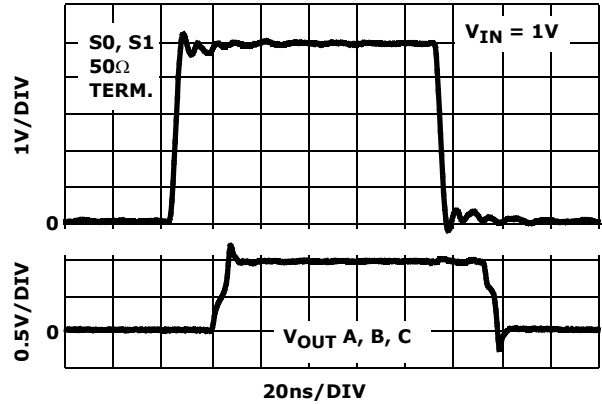

FIGURE 12. CHANNEL TO CHANNEL TRANSIENT RESPONSE $V_{IN} = 1V$

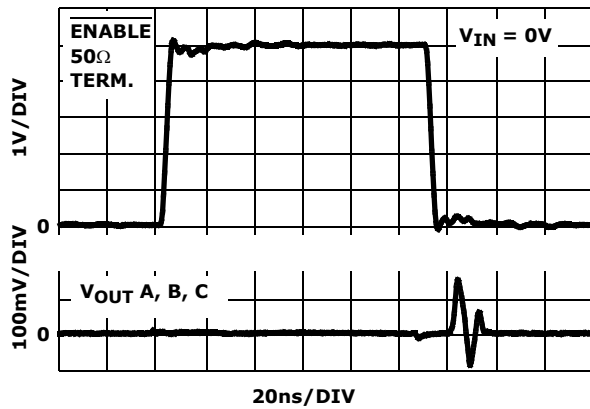

FIGURE 13. ENABLE SWITCHING GLITCH $V_{IN} = 0V$

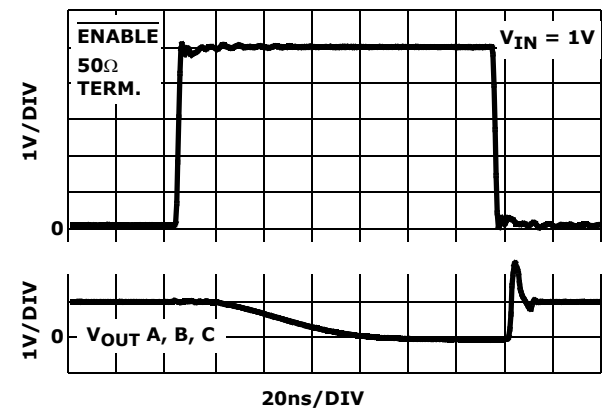

FIGURE 14. ENABLE TRANSIENT RESPONSE $V_{IN} = 1V$

Typical Performance Curves $V_S = \pm 5V$, $R_L = 500\Omega$ to GND, $T_A = +25^\circ C$, unless otherwise specified. (Continued)

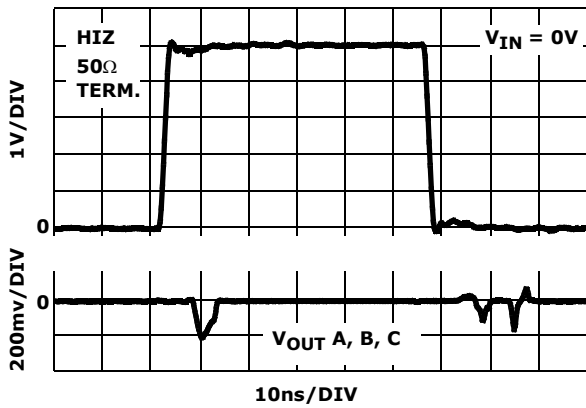

FIGURE 15. HIZ SWITCHING GLITCH $V_{IN} = 0V$

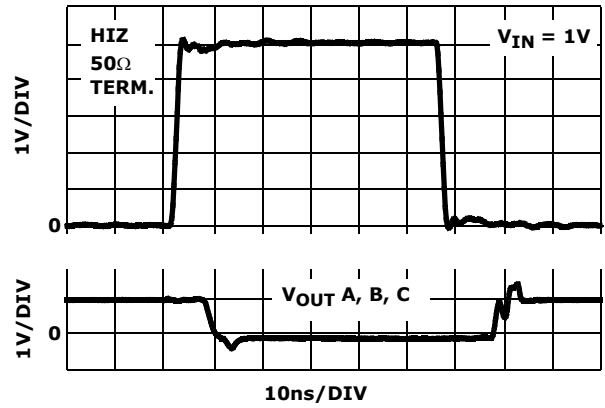

FIGURE 16. HIZ TRANSIENT RESPONSE $V_{IN} = 1V$

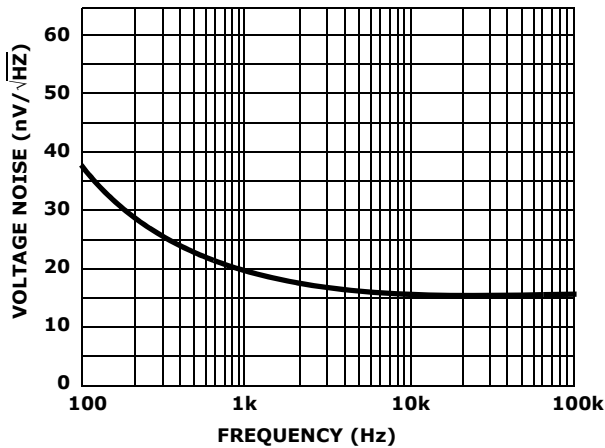

FIGURE 17. INPUT NOISE vs FREQUENCY (OUTPUT A, B, C)

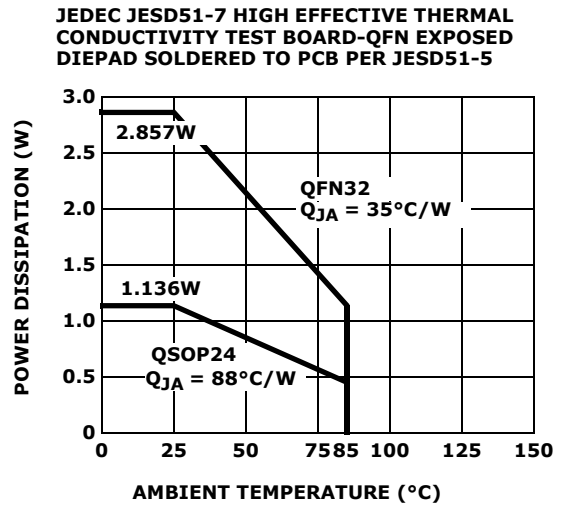

FIGURE 18. PACKAGE POWER DISSIPATION vs AMBIENT TEMPERATURE

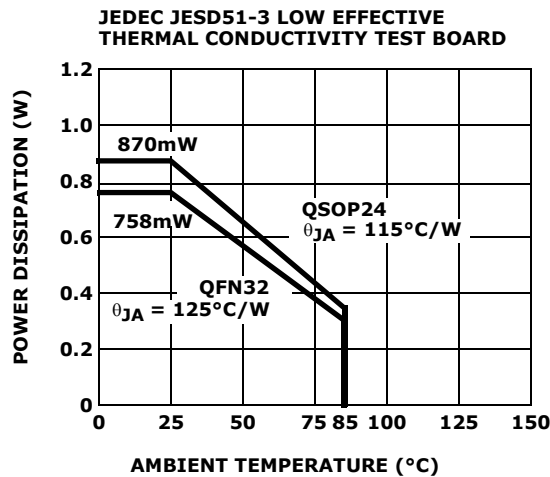
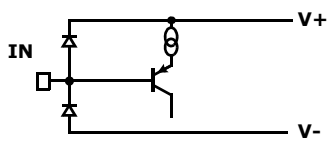

FIGURE 19. PACKAGE POWER DISSIPATION VS AMBIENT TEMPERATURE

Pin Descriptions

| EL4342 (32 LD QFN) | EL4340 (24 LD QSOP) | PIN NAME | EQUIVALENT CIRCUIT | DESCRIPTION |
|--------------------------------|------------------------|----------------------------|-----------------------|-------------------------------------------------------------------------------------------------------------------------------------------------------------------------------------------------------------------------------------------------------------------------------------------------------------------------------------------------------------------------------------------------------|
| 1 | 8 | IN1A | Circuit 1 | Channel 1 input for output amplifier "A" |
| 2, 4, 8, 13, 15, 24, 28, 30 | 4, 7, 9, 13, 15, 24 | NIC | | Not Internally Connected; it is recommended these pins be tied to ground to minimize crosstalk. |
| 3 | 10 | IN1B | Circuit 1 | Channel 1 input for output amplifier "B" |
| 5 | 12 | IN1C | Circuit 1 | Channel 1 input for output amplifier "C" |
| 6 | 5 | GNDB | Circuit 4 | Ground pin for output amplifier "B" |
| 7 | NA | IN2A | Circuit 1 | Channel 2 input for output amplifier "A" |
| 9 | NA | IN2B | Circuit 1 | Channel 2 input for output amplifier "B" |
| 10 | NA | IN2C | Circuit 1 | Channel 2 input for output amplifier "C" |
| 11 | 11 | GNDC | Circuit 4 | Ground pin for output amplifier "C" |
| 12 | NA | IN3A | Circuit 1 | Channel 3 input for output amplifier "A" |
| 14 | NA | IN3B | Circuit 1 | Channel 3 input for output amplifier "B" |
| 16 | NA | IN3C | Circuit 1 | Channel 3 input for output amplifier "C" |
| 17 | NA | S1 | Circuit 2 | Channel selection pin MSB (binary logic code) |
| 18 | 14 | S0 | Circuit 2 | Channel selection pin. LSB (binary logic code) |
| 19 | 17 | OUTC | Circuit 3 | Output of amplifier "C" |
| 20 | 18 | OUTB | Circuit 3 | Output of amplifier "B" |
| 21 | 16 | V- | Circuit 4 | Negative power supply |
| 22 | 20 | OUTA | Circuit 3 | Output of amplifier "A" |
| 23 | 19 | V+ | Circuit 4 | Positive power supply |
| 25 | 22 | $\overline{\text{ENABLE}}$ | Circuit 2 | Device enable (active low). Internal pull-down resistor ensures the device will be active with no connection to this pin. A logic High on this pin puts device into power-down mode. In power-down mode only logic circuitry is active. All logic states are preserved post power-down. This state is not recommended for logic control where more than one MUX-amp share the same video output line. |
| - | 23 | $\overline{\text{LE}}$ | Circuit 2 | Device latch enable on the EL4340. A logic high on $\overline{\text{LE}}$ will latch the last (S0, S1) logic state. HIZ and $\overline{\text{ENABLE}}$ functions are not latched with the $\overline{\text{LE}}$ pin. |
| 26 | 21 | HIZ | Circuit 2 | Output disable (active high). Internal pull-down resistor ensures the device will be active with no connection to this pin. A logic high, puts the outputs in a high impedance state. Use this state to control logic when more than one MUX-amp share the same video output line. |
| 27 | 6 | IN0C | Circuit 1 | Channel 0 for output amplifier "C" |
| 29 | 3 | IN0B | Circuit 1 | Channel 0 for output amplifier "B" |
| 31 | 1 | IN0A | Circuit 1 | Channel 0 for output amplifier "A" |
| 32 | 2 | GNDA | Circuit 4 | Ground pin for output amplifier "A" |



CIRCUIT 1

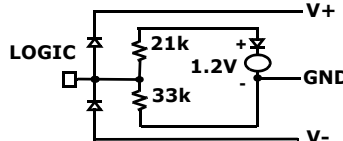

CIRCUIT 2

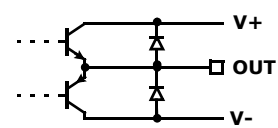

CIRCUIT 3

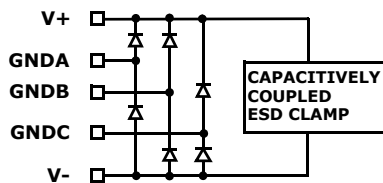

CIRCUIT 4

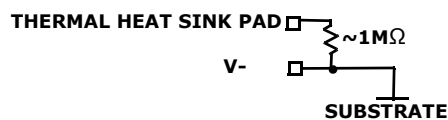

AC Test Circuits

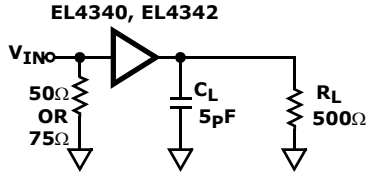

FIGURE 20A. TEST CIRCUIT WITH OPTIMAL OUTPUT LOAD

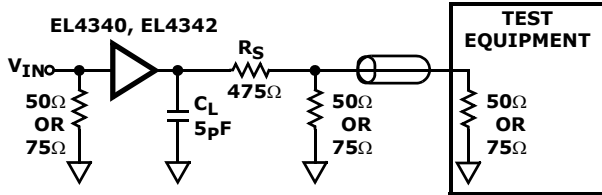

FIGURE 20B. TEST CIRCUIT FOR MEASURING WITH 50Ω OR 75Ω INPUT TERMINATED EQUIPMENT

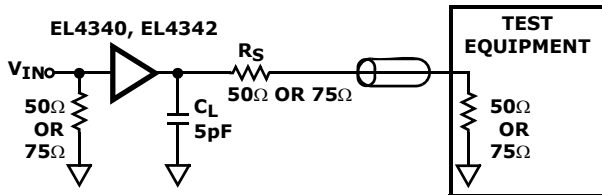

FIGURE 20C. BACKLOADED TEST CIRCUIT FOR VIDEO CABLE APPLICATION. BANDWIDTH AND LINEARITY FOR R_L LESS THAN 500Ω WILL BE DEGRADED.

FIGURE 20. TEST CIRCUITS

Figure 20A illustrates the optimum output load for testing AC performance. Figure 20B illustrates the optimum output load when connecting to 50Ω input terminated equipment.

Application Information

General

The EL4340, EL4342 triple 2:1 and 4:1 MUX amps are ideal as the matrix element of high performance switchers and routers. Key features include buffered high impedance analog inputs and excellent AC performance at output loads down to 150Ω for video cable-driving. The unity-gain current feedback output amplifiers are stable operating into capacitive loads and bandwidth is optimized with a load of 5pF in parallel with a 500Ω. Total output capacitance can be

split between the PCB capacitance and an external load capacitor.

Ground Connections

For the best isolation and crosstalk rejection, all GND pins and NIC pins must connect to the GND plane.

Control Signals

S0, S1, $\overline{\text{ENABLE}}$, $\overline{\text{LE}}$, HIZ - These are binary coded, TTL/CMOS compatible control inputs. The S0, S1 pins select the inputs. All three amplifiers are switched simultaneously from their respective inputs. The $\overline{\text{ENABLE}}$, $\overline{\text{LE}}$, HIZ pins are used to disable the part to save power, latch in the last logic state and three-state the output amplifiers, respectively. For control signal rise and fall times less than 10ns the use of termination resistors close to the part will minimize transients coupled to the output.

Power-up Considerations

The ESD protection circuits use internal diodes from all pins the V+ and V- supplies. In addition, a dV/dT-triggered clamp is connected between the V+ and V- pins, as shown in the Equivalent Circuits 1 through 4 section of the Pin Description table. The dV/dT triggered clamp imposes a maximum supply turn-on slew rate of 1V/μs. Damaging currents can flow for power supply rates-of-rise in excess of 1V/μs, such as during hot plugging. Under these conditions, additional methods should be employed to ensure the rate of rise is not exceeded.

Consideration must be given to the order in which power is applied to the V+ and V- pins, as well as analog and logic input pins. Schottky diodes (Motorola MBR0550T or equivalent) connected from V+ to ground and V- to ground (Figure 21) will shunt damaging currents away from the internal V+ and V- ESD diodes in the event that the V+ supply is applied to the device before the V- supply.

If positive voltages are applied to the logic or analog video input pins before V+ is applied, current will flow through the internal ESD diodes to the V+ pin. The presence of large decoupling capacitors and the loading effect of other circuits connected to V+, can result in damaging currents through the ESD diodes and other active circuits within the device. Therefore, adequate current limiting on the digital and analog inputs is needed to prevent damage during the time the voltages on these inputs are more positive than V+.

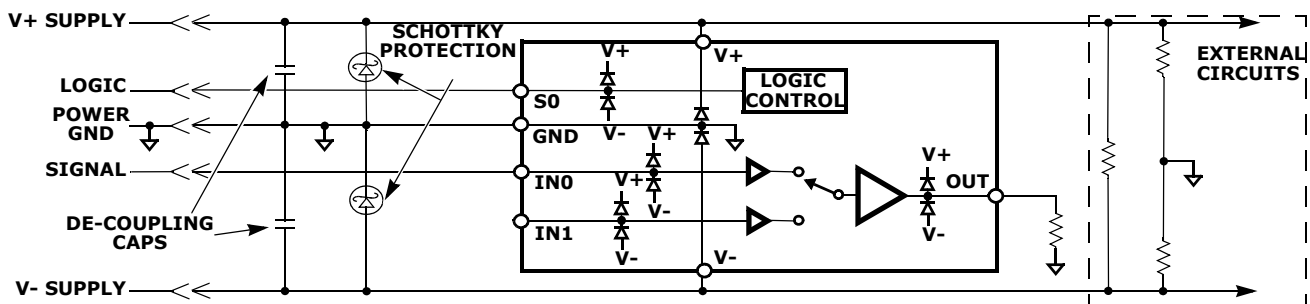

FIGURE 21. SCHOTTKY PROTECTION CIRCUIT

HIZ State

An internal pull-down resistor ensures the device will be active with no connection to the HIZ pin. The HIZ state is established within approximately 15ns (Figure 16) by placing a logic high (>2V) on the HIZ pin. If the HIZ state is selected, the output is a high impedance 1.4MΩ with approximately 1.5pF in parallel with a 10μA bias current from the output. Use this state when more than one mux shares a common output.

In the HIZ state the output is three-stated, and maintains its high Z even in the presence of high slew rates. The supply current during this state is same as the active state.

ENABLE and Power-down States

The enable pin is active low. An internal pull-down resistor ensures the device will be active with no connection to the ENABLE pin. The Power-down state is established within approximately 80ns (Figure 14), if a logic high (>2V) is placed on the ENABLE pin. In the Power-down state, the output has no leakage but has a large variable capacitance (on the order of 15pF), and is capable of being back-driven. Under this condition, large incoming slew rates can cause fault currents of tens of mA. **Do not use this state as a high impedance output when several MUX amps share the same output line.**

LE State

The EL4340 is equipped with a Latch Enable pin. A logic high (>2V) on the LE pin latches the last logic state. This logic state is preserved when cycling HIZ or ENABLE functions.

Limiting the Output Current

No output short circuit current limit exists on these parts. All applications need to limit the output current to less than 50mA. Adequate thermal heat sinking of the parts is also required.

Application Example

Figure 22 illustrates the use of the EL4342, two ISL84517 SPST switches and one NC7ST00P5X NAND gate to mux 3 different component video signals and one RGB video signal. The SPDT switches provide the sync signal for the RGB video and disconnects the sync signal for the component signal.

PC Board Layout

The AC performance of this circuit depends greatly on the care taken in designing the PC board. The following are recommendations to achieve optimum high frequency performance from your PC board.

- The use of low inductance components such as chip resistors and chip capacitors is strongly recommended.
- Minimize signal trace lengths. Trace inductance and capacitance can easily limit circuit performance. Avoid

sharp corners, use rounded corners when possible. Vias in the signal lines add inductance at high frequency and should be avoided. PCB traces greater than 1" begin to exhibit transmission line characteristics with signal rise/fall times of 1ns or less. High frequency performance may be degraded for traces greater than one inch, unless strip line are used.

- Match channel-channel analog I/O trace lengths and layout symmetry. This will minimize propagation delay mismatches.
- Maximize use of AC de-coupled PCB layers. All signal I/O lines should be routed over continuous ground planes (i.e. no split planes or PCB gaps under these lines). Avoid vias in the signal I/O lines.
- Use proper value and location of termination resistors. Termination resistors should be as close to the device as possible.
- When testing use good quality connectors and cables, matching cable types and keeping cable lengths to a minimum.
- Minimum of 2 power supply de-coupling capacitors are recommended (1000pF, 0.01μF) as close to the devices as possible - Avoid vias between the cap and the device because vias add unwanted inductance. Larger caps can be farther away. When vias are required in a layout, they should be routed as far away from the device as possible.
- The NIC pins are placed on both sides of the input pins. These pins are not internally connected to the die. It is recommended these pins be tied to ground to minimize crosstalk.

The QFN Package Requires Additional PCB Layout Rules for the Thermal Pad

The thermal pad is electrically connected to V- supply through the high resistance IC substrate. Its primary function is to provide heat sinking for the IC. However, because of the connection to the V- supply through the substrate, the thermal pad must be tied to the V- supply to prevent unwanted current flow to the thermal pad. Do **not** tie this pin to GND as this could result in large back biased currents flowing between GND and V-. The EL4342 uses the package with pad dimensions of D2 = 2.48mm and E2 = 3.4mm.

Maximum AC performance is achieved if the thermal pad is attached to a dedicated de-coupled layer in a multi-layered PC board. In cases where a dedicated layer is not possible, AC performance may be reduced at upper frequencies.

The thermal pad requirements are proportional to power dissipation and ambient temperature. A dedicated layer eliminates the need for individual thermal pad area. When a dedicated layer is not possible a 1" x 1" pad area is sufficient for the EL4342 that is dissipating 0.5W in +50°C ambient. Pad area requirements should be evaluated on a case by case basis.

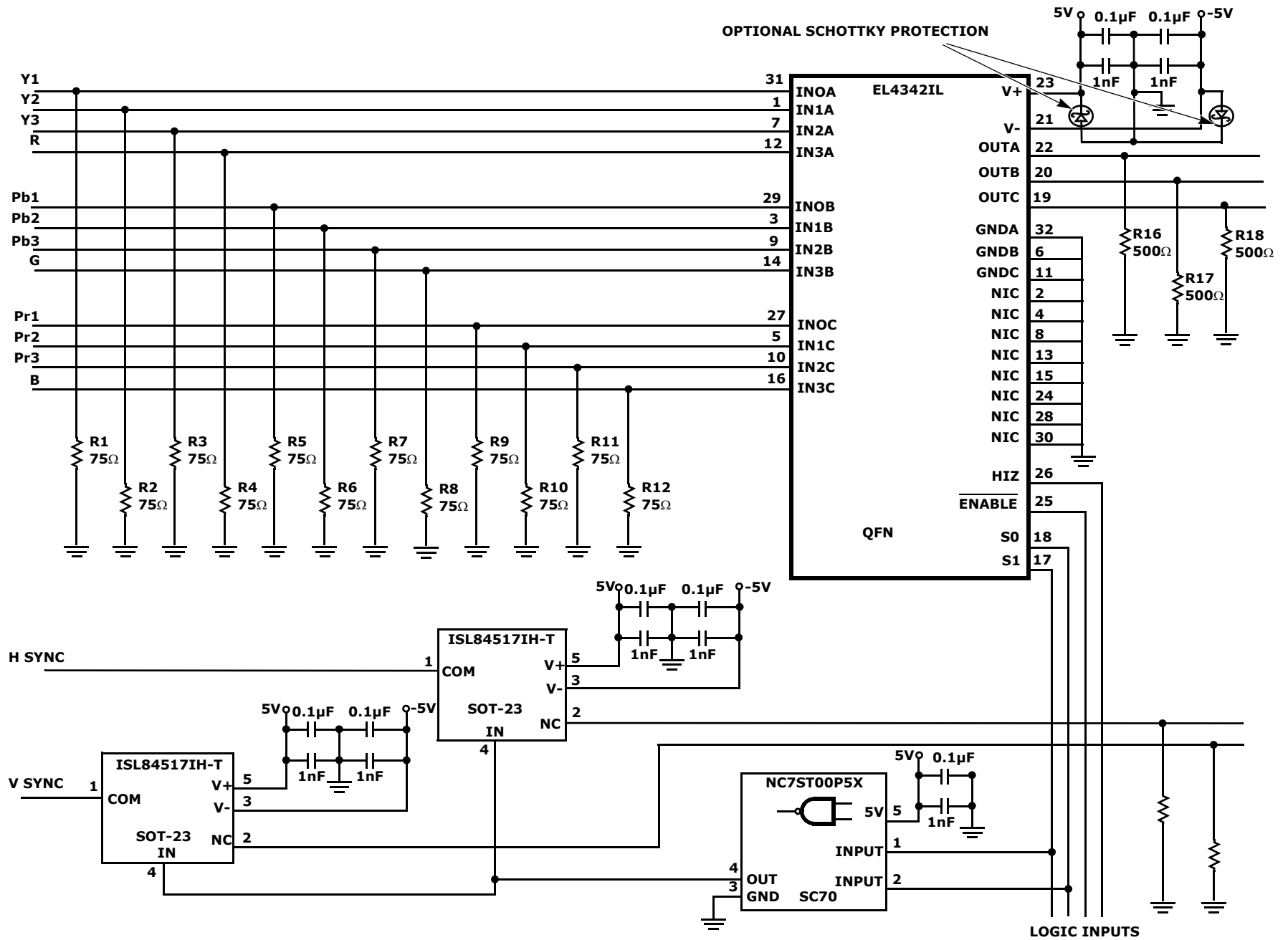
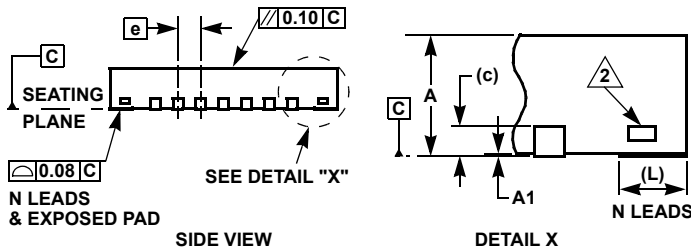
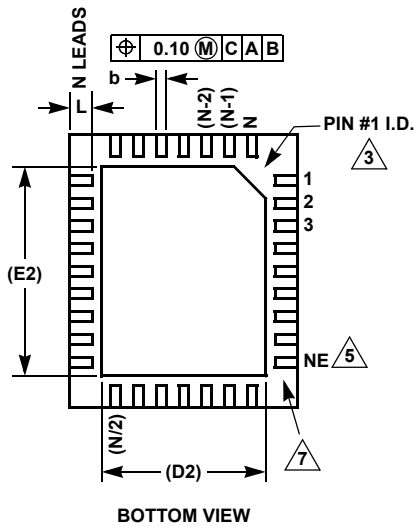
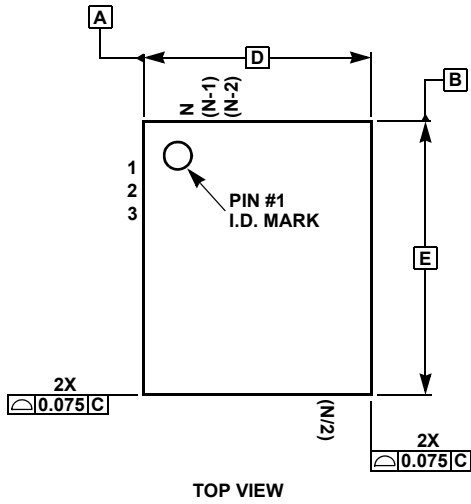

FIGURE 22. APPLICATION SHOWING THREE YPBPR CHANNELS AND ONE RGB+HV CHANNEL

EL4340, EL4342

**Quad Flat No-Lead Plastic Package (QFN)
Micro Lead Frame Plastic Package (MLFP)**

L32.5x6A (One of 10 Packages in MDP0046)
32 LEAD QUAD FLAT NO-LEAD PLASTIC PACKAGE
(COMPLIANT TO JEDEC MO-220)



| SYMBOL | MILLIMETERS | | | NOTES |
|--------|-------------|---------|------|-------|
| | MIN | NOMINAL | MAX | |
| A | 0.80 | 0.90 | 1.00 | - |
| A1 | 0.00 | 0.02 | 0.05 | - |
| D | 5.00 BSC | | | - |
| D2 | 2.48 REF | | | - |
| E | 6.00 BSC | | | - |
| E2 | 3.40 REF | | | - |
| L | 0.45 | 0.50 | 0.55 | - |
| b | 0.17 | 0.22 | 0.27 | - |
| c | 0.20 REF | | | - |
| e | 0.50 BSC | | | - |
| N | 32 REF | | | 4 |
| ND | 7 REF | | | 6 |
| NE | 9 REF | | | 5 |

Rev 1 2/09

NOTES:

1. Dimensioning and tolerancing per ASME Y14.5M-1994.
2. Tiebar view shown is a non-functional feature.
3. Bottom-side pin #1 I.D. is a diepad chamfer as shown.
4. N is the total number of terminals on the device.
5. NE is the number of terminals on the "E" side of the package (or Y-direction).
6. ND is the number of terminals on the "D" side of the package (or X-direction). $ND = (N/2) - NE$.
7. Inward end of terminal may be square or circular in shape with radius $(b/2)$ as shown.

Quarter Size Outline Plastic Packages Family (QSOP)

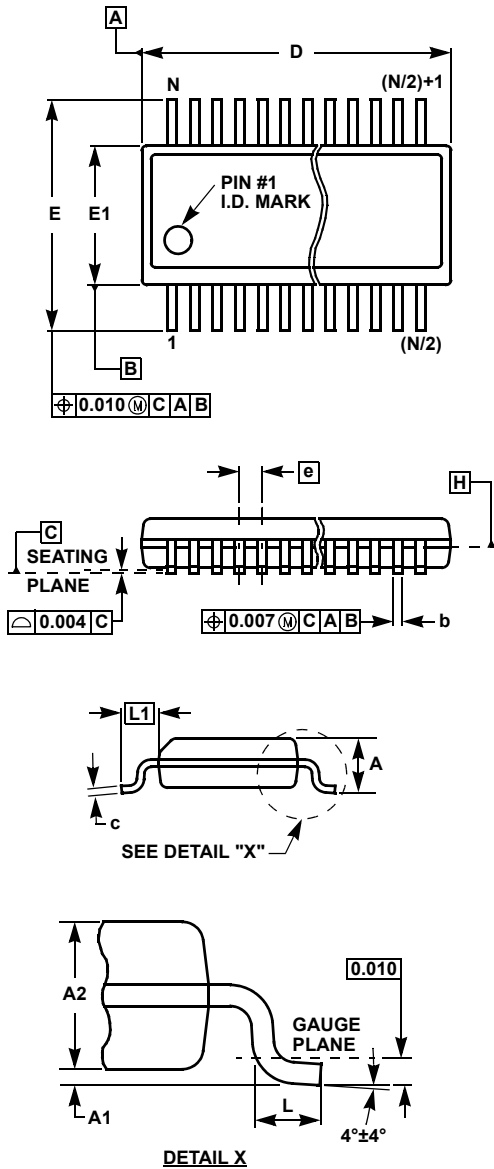

MDP0040

QUARTER SIZE OUTLINE PLASTIC PACKAGES FAMILY

| SYMBOL | INCHES | | | TOLERANCE | NOTES |
|--------|--------|--------|--------|-----------|-------|
| | QSOP16 | QSOP24 | QSOP28 | | |
| A | 0.068 | 0.068 | 0.068 | Max. | - |
| A1 | 0.006 | 0.006 | 0.006 | ±0.002 | - |
| A2 | 0.056 | 0.056 | 0.056 | ±0.004 | - |
| b | 0.010 | 0.010 | 0.010 | ±0.002 | - |
| c | 0.008 | 0.008 | 0.008 | ±0.001 | - |
| D | 0.193 | 0.341 | 0.390 | ±0.004 | 1, 3 |
| E | 0.236 | 0.236 | 0.236 | ±0.008 | - |
| E1 | 0.154 | 0.154 | 0.154 | ±0.004 | 2, 3 |
| e | 0.025 | 0.025 | 0.025 | Basic | - |
| L | 0.025 | 0.025 | 0.025 | ±0.009 | - |
| L1 | 0.041 | 0.041 | 0.041 | Basic | - |
| N | 16 | 24 | 28 | Reference | - |

Rev. F 2/07

NOTES:

1. Plastic or metal protrusions of 0.006" maximum per side are not included.
2. Plastic interlead protrusions of 0.010" maximum per side are not included.
3. Dimensions "D" and "E1" are measured at Datum Plane "H".
4. Dimensioning and tolerancing per ASME Y14.5M-1994.

All Intersil U.S. products are manufactured, assembled and tested utilizing ISO9000 quality systems. Intersil Corporation's quality certifications can be viewed at www.intersil.com/design/quality

Intersil products are sold by description only. Intersil Corporation reserves the right to make changes in circuit design, software and/or specifications at any time without notice. Accordingly, the reader is cautioned to verify that data sheets are current before placing orders. Information furnished by Intersil is believed to be accurate and reliable. However, no responsibility is assumed by Intersil or its subsidiaries for its use; nor for any infringements of patents or other rights of third parties which may result from its use. No license is granted by implication or otherwise under any patent or patent rights of Intersil or its subsidiaries.

For information regarding Intersil Corporation and its products, see www.intersil.com