

## General Description

The AHK3292 is a linear current-sink LED driver, capable of driving one or two LEDs up to 30.2mA each. Featuring individual low resistance, low drop-out voltage current sinks, the AHK3292 allows the LEDs to be regulated directly from a Lithium Ion/Polymer battery without the need for an additional step-up power supply, thereby reducing the external component count, eliminating switching noise and maximizing efficiency.

AnalogicTech's Simple Serial Control™ (S<sup>2</sup>Cwire™) interface is used to enable, disable, and set the LED drive current for 32-level linear scale LED brightness control. For maximum flexibility the LED current can be set, up to a maximum of 30.2mA per channel, using an external R<sub>SET</sub> resistor.

The AHK3292 is packaged in a Pb-free 6-pin SOT23 package and is available over a -40 to +85°C temperature range.

## Features

- 2.7V to 5.5V Input Supply Range
- Drives up to 2 LEDs at up to 30.2mA each
- Low Resistance Current Sinks
  - Low Dropout, Typically 40.5mV at Full Scale
- Linear LED Output Current Control
  - S<sup>2</sup>Cwire Interface
    - Single-wire
    - 32 Steps
- ±10% LED Output Current Accuracy
- ±3% LED Output Current Matching
- Low Current Shutdown Mode
- Low Cost 6-pin SOT23 Package

## Applications

- Entry Level Mobile Phones
- Indicator LEDs
- Keyboard Backlight
- MP3 Players

## Typical Application Circuit

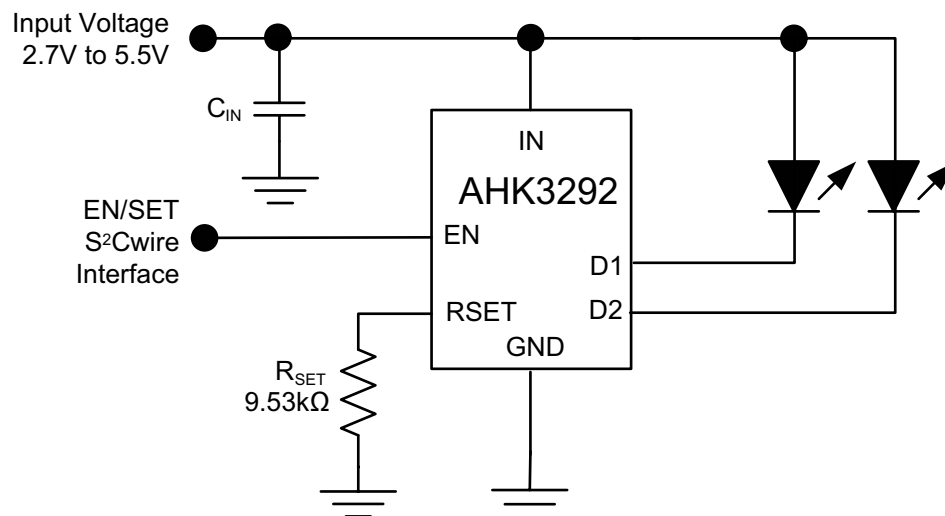

## Pin Descriptions

Pin #	Symbol	Function	Description
1	EN	I	S <sup>2</sup> Cwire serial input. EN is used for ON/OFF control. EN is also the data input for the S <sup>2</sup> Cwire interface used to control the 32 levels of LED brightness according to the current set by RSET.
2	GND	I/O	Ground. Connect this pin to the system ground.
3	IN	I	Input power pin. Connect IN to the power source, typically the battery. Bypass IN to GND with a 1μF or larger ceramic capacitor.
4	D2	O	Backlight LED 2 current sink output. Connect the cathode of LED 2 to D2. If not used, connect D2 to IN.
5	RSET	I	Connect resistor from this pin to GND to set the maximum LED current level. For optimal LED output current accuracy and matching in the AHK3292, use a 9.53kΩ 1% resistor to set each full-scale output current to 30.2mA maximum.
6	D1	O	Backlight LED 1 current sink output. Connect the cathode of LED 1 to D1. If not used, connect D1 to IN.

## Pin Configuration

**SOT23-6  
(Top View)**

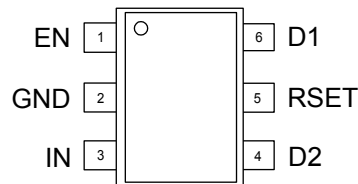

## Absolute Maximum Ratings<sup>1</sup>

T<sub>A</sub> = 25°C unless otherwise noted.

Symbol	Description	Value	Units
V <sub>N</sub>	IN, D1, D2, and RSET to GND	-0.3 to 6.0	V
V <sub>EN</sub>	VEN to GND	-0.3 to V <sub>IN</sub> +0.3	

## Thermal Information<sup>2</sup>

Symbol	Description	Value	Units
Θ <sub>JA</sub>	Thermal Resistance <sup>3</sup>	150	°C/W
P <sub>D</sub>	Maximum Power Dissipation	667	mW
T <sub>J</sub>	Operating Junction Temperature Range	-40 to 150	°C
T <sub>LEAD</sub>	Maximum Soldering Temperature (at Leads)	300	

1. Stresses above those listed in Absolute Maximum Ratings may cause permanent damage to the device. Functional operation at conditions other than the operating conditions specified is not implied. Only one Absolute Maximum Rating should be applied at any one time.

2. Mounted on an FR4 board.

3. Derate 5.3mW/°C above 25°C.

## Electrical Characteristics<sup>1</sup>

IN = EN = 3.6V, C<sub>IN</sub> = 1μF, R<sub>SET</sub> = 9.53kΩ; T<sub>A</sub> = -40°C to 85°C unless otherwise noted. Typical values are at T<sub>A</sub> = 25°C.

Symbol	Description	Conditions	Min	Typ	Max	Units
<b>Power Supply</b>						
V <sub>IN</sub>	Input Voltage Range		2.7		5.5	V
I <sub>IN</sub>	Input Operating Current	I <sub>D1</sub> = I <sub>D2</sub> = 30.2mA (DATA 1), excluding I <sub>D1</sub> and I <sub>D2</sub>			1.8	mA
I <sub>IN(SHDN)</sub>	Input Shutdown Current	IN = 5.5V; EN = GND			1	μA
V <sub>DO</sub>	Current Sink Dropout Voltage <sup>2</sup>	I <sub>D1</sub> = I <sub>D2</sub> = 30.2mA (DATA 1)		40.5	125	mV
		I <sub>D1</sub> = I <sub>D2</sub> = 15.2mA (DATA 16)		36	85	
<b>LED Current Sink Outputs</b>						
I <sub>D(MAX)</sub>	D1, D2 Current Accuracy	I <sub>D1</sub> = I <sub>D2</sub> = 30.2mA (DATA 1)	27.18	30.2	33.22	mA
ΔI <sub>D(MAX)</sub>	D1, D2 Current Matching	I <sub>D1</sub> = I <sub>D2</sub> = 30.2mA (DATA 1)		±3		%
t <sub>S</sub>	Start-up Period	EN = IN		150		μs
I <sub>SET</sub>	Current Set Ratio	I <sub>SINK</sub> /I <sub>RSET</sub>		240		A/A
V <sub>SET</sub>	RSET Pin Voltage			1.2		V
<b>EN and S<sup>2</sup>Cwire Control</b>						
V <sub>EN(L)</sub>	EN Input Low Threshold				0.4	V
V <sub>EN(H)</sub>	EN Input High Threshold		1.4			V
I <sub>EN</sub>	EN Input Leakage Current	EN = IN = 5V	-1		1	μA
T <sub>EN(LOW)</sub>	EN Serial Interface Low Time		0.3		75	μs
T <sub>EN(HI_MIN)</sub>	Minimum EN high Time			50		ns
T <sub>EN(HI_MAX)</sub>	Maximum EN High Time				75	μs
T <sub>EN(OFF)</sub>	EN Off Timeout				500	μs
T <sub>EN(LAT)</sub>	EN Latch Timeout				500	μs

1. The AHK3292 is guaranteed to meet the performance specifications over the -40°C to +85°C operating temperature range and is assured by design, characterization and correlation with statistical process controls.  
 2. The current sink drop-out voltage is defined as when the current at D1 or D2 drops to 90% of its nominal value.

## Typical Characteristics

Quiescent Current vs. Input Voltage

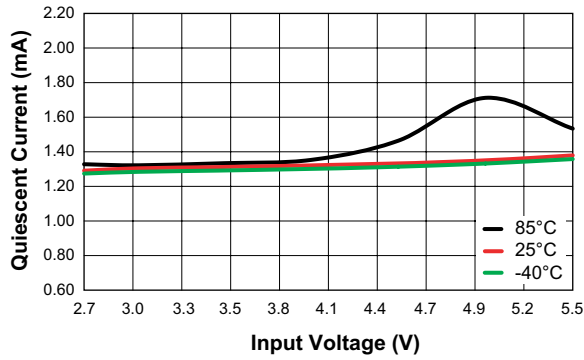

Shutdown Current vs. Temperature

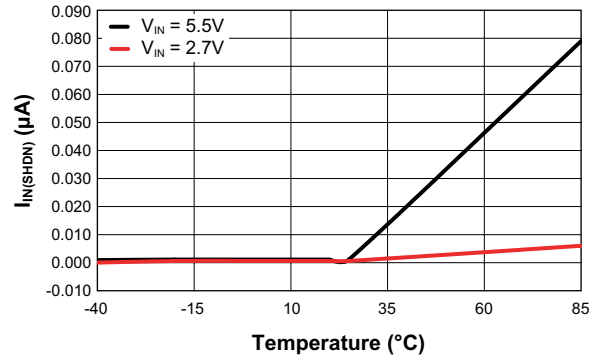

Line Regulation  
(30.2mA/ch)

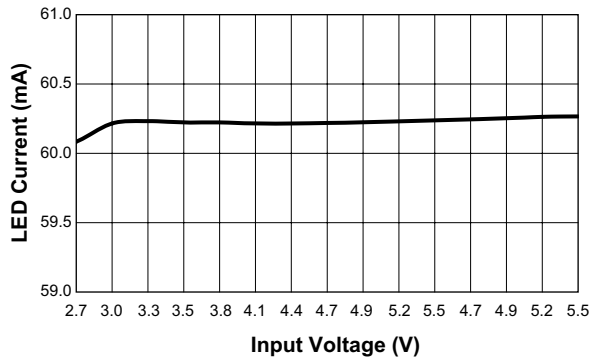

Efficiency vs. Input Voltage  
(30.2mA/ch)

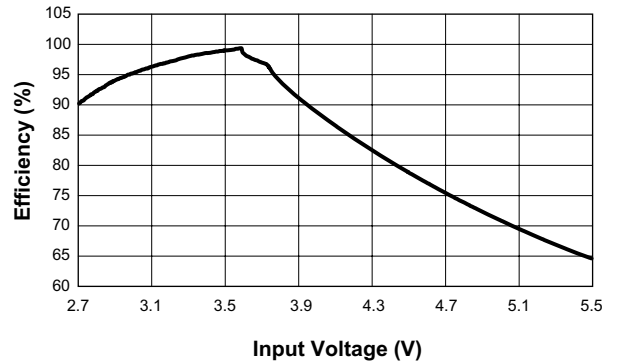

D1, D2 Current Matching

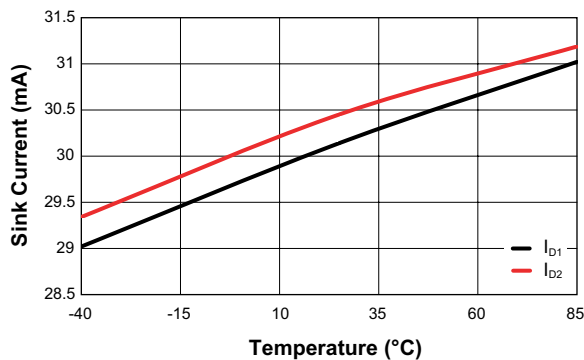

**Typical Characteristics**

**Turn On**  
( $V_{IN} = 3.6V$ ; 30.2mA/ch)

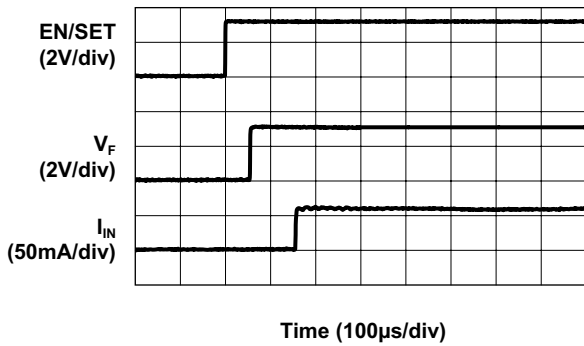

**Turn Off**  
( $V_{IN} = 3.6V$ ; 30.2mA/ch)

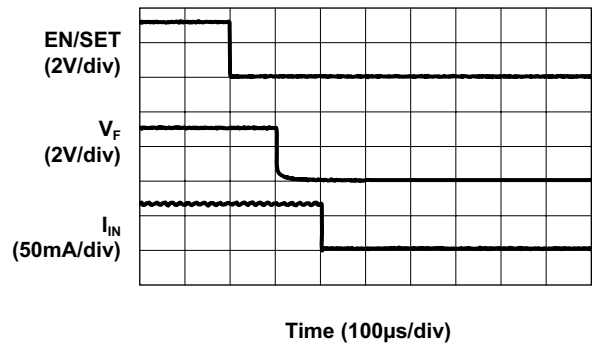

**EN Input High Threshold vs. Input Voltage**

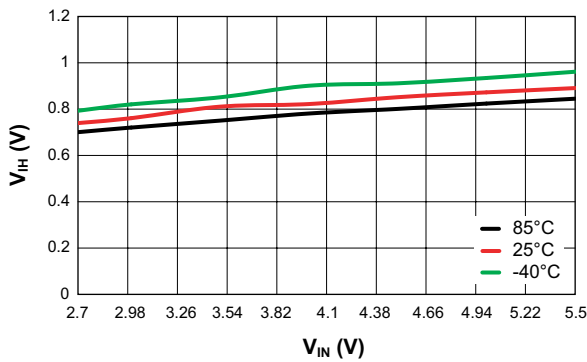

**EN Input Low Threshold vs. Input Voltage**

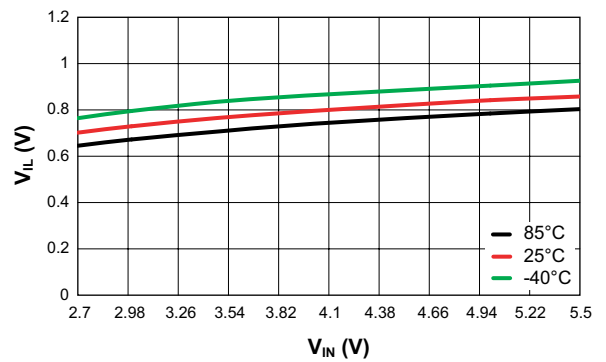

**EN Input Latch Timeout vs. Input Voltage**

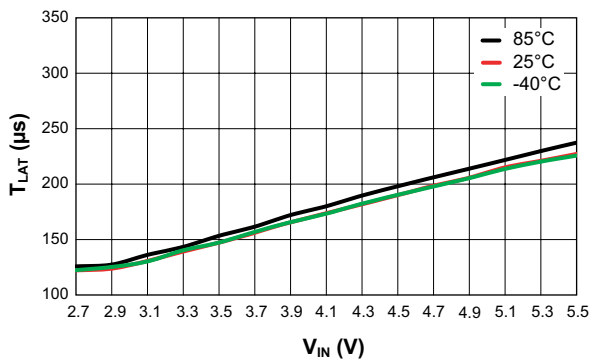

**EN Input OFF Timeout vs. Input Voltage**

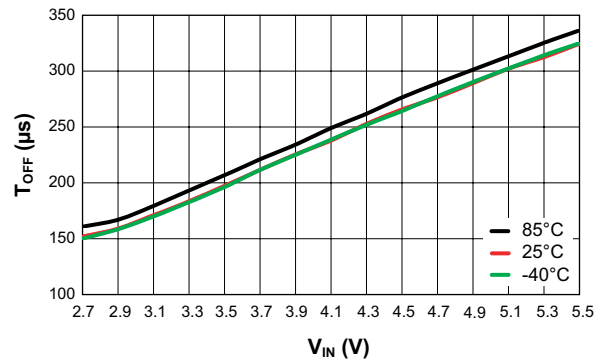

## Functional Block Diagram

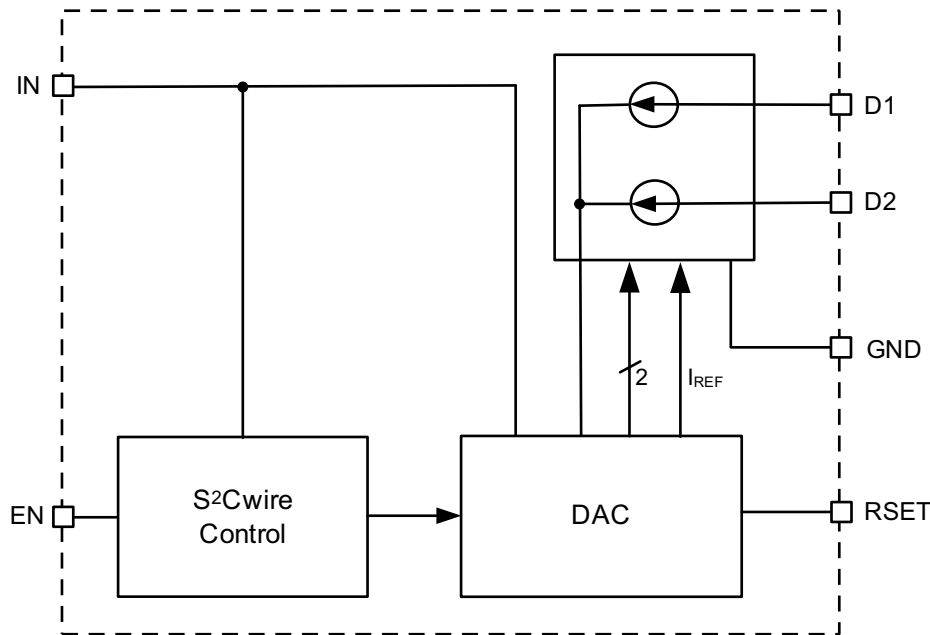

## Functional Description

The AHK3292 is an entry level driver IC, designed to drive up to two white LEDs. The AHK3292 operates directly from a 2.7V to 5.5V power source and enables and controls the currents to the diodes. Both channels are individually controlled through integrated current sinks powered from an external power supply. Low resistance and low-dropout voltage current sinks allow the LEDs to operate very close to the input supply voltage, eliminating the need for an additional boost power supply.

The AHK3292 requires only two external components: one  $1\mu\text{F}$  ceramic input capacitor ( $C_{IN}$ ), and a resistor ( $R_{SET}$ ) to set the maximum LED current. The AHK3292 can drive two constant output sinks, D1 and D2, up to 30.2mA maximum current each. AnalogicTech's S<sup>2</sup>Cwire serial interface enables the AHK3292 and changes the current sink magnitude through the EN pin.

### S<sup>2</sup>Cwire Serial Interface

The LED output current of the AHK3292 is controlled by AnalogicTech's S<sup>2</sup>Cwire serial interface. Since the LED current is programmable, no PWM or additional control

circuitry is needed to control LED brightness. This feature greatly reduces the burden on a microcontroller or system IC to manage LED or display brightness, allowing the user to "set it and forget it." With its high-speed serial interface (1MHz data rate), the LED current can be changed quickly and easily. Also the non-pulsating LED current reduces system noise and improves LED reliability.

The S<sup>2</sup>Cwire interface relies on the number of rising edges to the EN/SET pin to set the register. A typical write protocol is a burst of EN rising edges, followed by a pause with EN held high for at least  $t_{LAT}$  (500 $\mu\text{s}$ ). The programmed current is then seen at the current sink outputs. When EN is held low for an amount of time longer than  $t_{OFF}$  (500 $\mu\text{s}$ ), the AHK3292 enters into shutdown mode and draws less than  $1\mu\text{A}$  from the input and the internal data register is reset to zero.

The AHK3292 serial interface reduces the LED current on each rising pulse of the enable input. If the AHK3292 is in shutdown, the first rising edge of the EN input turns on the LED driver to the maximum current. Successive rising edges decrease the LED current according to Table 1 and Figure 2.

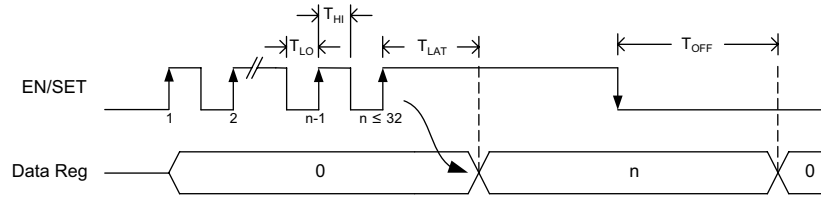
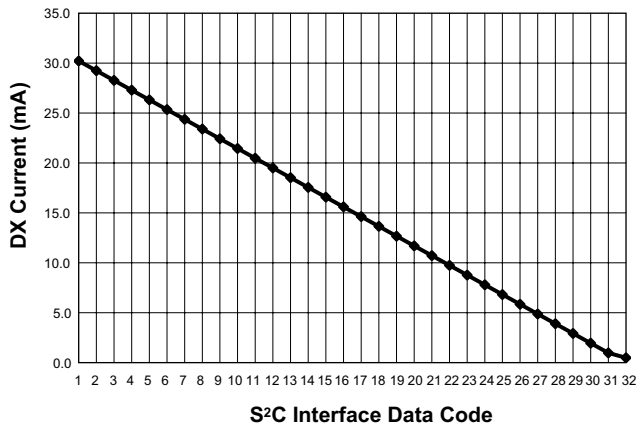

**Figure 1: S²Cwire Serial Interface Timing.**

Data	EN Rising Edges	D1- D2 Output Current (mA)	Data	EN Rising Edges	D1-D2 Output Current (mA)
1	1	30.2	17	17	14.6
2	2	29.2	18	18	13.6
3	3	28.3	19	19	12.7
4	4	27.3	20	20	11.7
5	5	26.3	21	21	10.7
6	6	25.3	22	22	9.7
7	7	24.4	23	23	8.8
8	8	23.4	24	24	7.8
9	9	22.4	25	25	6.8
10	10	21.4	26	26	5.8
11	11	20.5	27	27	4.9
12	12	19.5	28	28	3.9
13	13	18.5	29	29	2.9
14	14	17.5	30	30	1.9
15	15	16.6	31	31	1.0
16	16	15.6	32	32	0.5

**Table 1: AHK3292 LED Current Settings.**

**S²C Interface Data Code**



**Figure 2: AHK3292 Current Profile.**

**Constant Current Control Using External R<sub>SET</sub>**

The AHK3292's maximum current is programmed by an external resistor connected to the RSET pin. The full-scale LED current can be set between 30.2mA and 0.5mA as shown on Figure 2. Table 2 shows R<sub>SET</sub> resistor values for various full-scale current levels. For maximum accuracy, a 1% tolerance resistor is recommended.

I <sub>LED</sub> (mA)	R <sub>SET</sub> (kΩ)
30.2	9.53
25	11.5
20.1	14.3
18.2	15.8
15.1	19.1
10	28.7

**Table 2: Maximum LED Current vs. R<sub>SET</sub> Resistor Values (1% Resistor Tolerance).**

## Applications Information

### LED Selection

The AHK3292 is specifically intended for driving white LEDs. However, the device design will allow the AHK3292 to drive most types of LEDs with forward voltage specifications typically ranging from 2.2V to 4.7V depending upon supply voltage. LED applications may include mixed arrangements for display backlighting, keypad display, and any other application that needs a constant current sink generated from a varying input voltage. Since the D1 to D2 constant current sinks are matched within 3% with negligible supply voltage dependence, the constant current channels will be matched regardless of the specific LED forward voltage ( $V_F$ ) levels. The low dropout current sinks in the AHK3292 maximize performance and make it capable of driving LEDs with high forward voltages. The two channels can be combined to obtain a higher LED drive current without complication.

### Shutdown

Since the current switches are the only power supplies for all loads, there is no leakage current when all sink switches are disabled. To activate the shutdown operation, the EN input for the AHK3292 should be strobed low for longer than  $t_{OFF}$  (500 $\mu$ s). In this state, the AHK3292 typically draws less than 1 $\mu$ A from the input. Registers are reset to 0 in shutdown.

### Additional Applications

The current sinks of the AHK3292 can be combined to drive higher current levels through a single LED. As an example, a single LED can typically be driven at 60.4mA total by combining together the D1-D2 outputs as shown in Figure 3.

### Capacitor Selection

Careful selection of the external capacitor  $C_{IN}$  is important because it will affect turn-on time and transient performance. Optimum performance will be obtained when low equivalent series resistance (ESR) ceramic capacitor is used; in general, low ESR may be defined as less than 100m $\Omega$ . A value of 1 $\mu$ F for the input capacitor is a good starting point when choosing it. If the constant current sinks are only programmed for light current levels, then the input capacitor size may be decreased.

### Capacitor Characteristics

Ceramic composition capacitor is highly recommended over all other types of capacitors for use with the AHK3292. Ceramic capacitors offer many advantages over their tantalum and aluminum electrolytic counterparts. A ceramic capacitor typically has very low ESR, is lower cost, has a smaller PCB footprint, and is non-polarized. Since ceramic capacitors are non-polarized, they are not prone to incorrect connection damage.

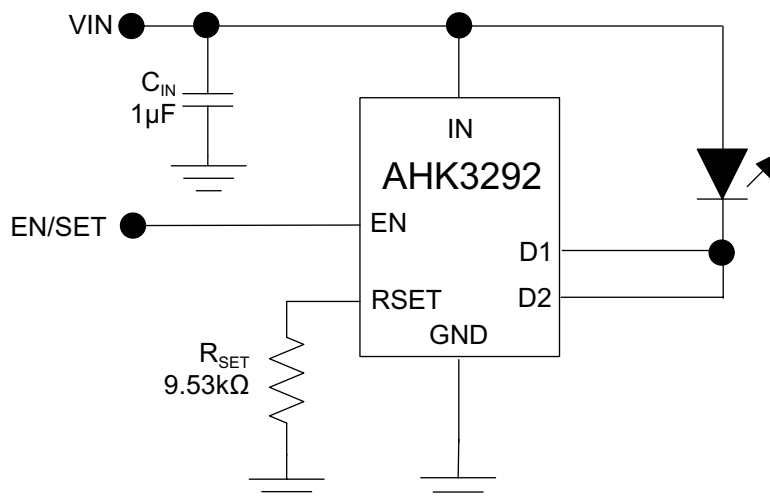

**Figure 3: Higher Current Single LED Application.**

**Equivalent Series Resistance**

ESR is an important characteristic to consider when selecting a capacitor. ESR is a resistance internal to a capacitor that is caused by the leads, internal connections, size or area, material composition, and ambient temperature. Capacitor ESR is typically measured in milliohms for ceramic capacitors and can range to more than several ohms for tantalum or aluminum electrolytic capacitors.

**Ceramic Capacitor Materials**

Ceramic capacitors less than 0.1µF are typically made from NPO or C0G materials. NPO and C0G materials generally have tight tolerance and are very stable over temperature. Larger capacitor values are usually composed of X7R, X5R, Z5U, or Y5V dielectric materials. Large ceramic capacitors (i.e., larger than 2.2µF) are often available in low cost Y5V and Z5U dielectrics, but capacitors larger than 1µF are not typically required for AHK3292 applications. Capacitor area is another contributor to ESR. Capacitors that are physically large will have a lower ESR when compared to an equivalent

material smaller capacitor. These larger devices can improve circuit transient response when compared to an equal value capacitor in a smaller package size.

**Evaluation Board User Interface**

The user interface for the AHK3292 evaluation board is provided by three buttons and two connection terminals. The board is operated by supplying external power and pressing individual buttons or button combinations. Table 3 indicates the function of each button or button combination.

To power-on the evaluation board, connect a power supply or battery to the DC- and DC+ terminals. A red LED indicates that power is applied. The evaluation board is made flexible so that the user can disconnect the enable line from the microcontroller and apply external enable signal. External enable signal must be applied to the EN pin.

When applying external enable signal, consideration must be given to the voltage levels. The externally applied voltage should not exceed the supply voltage that is applied to the IN pins of the device (DC+).

**User Interface Functionality**

Button(s) Pushed	Description
UP	[Push/Release once] D1 and D2 are turned on with 0.5mA per channel. With every push/release the current is increased according to Table 1.
DOWN	[Push/Release once] D1 and D2 are turned on with 30.2mA per channel. With every push/release the current is decreased according to Table 1.
CYCLE	[Push/Release together] Auto cycling up and down.

**Table 3: AHK3292 Evaluation Board User Interface.**



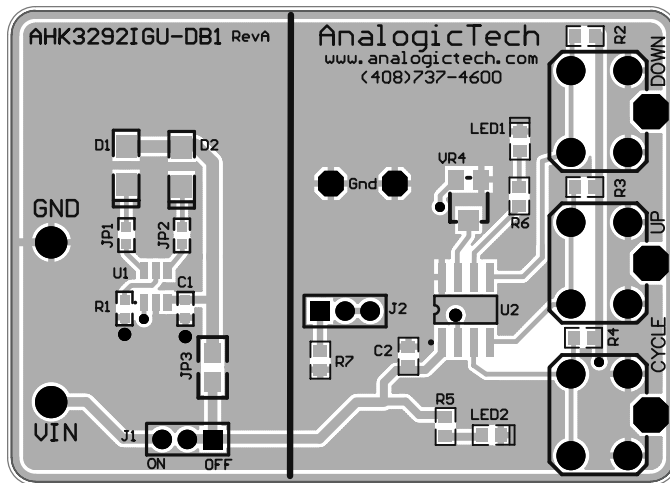

**Figure 5: AHK3292 Evaluation Board  
Top Side Layout.**

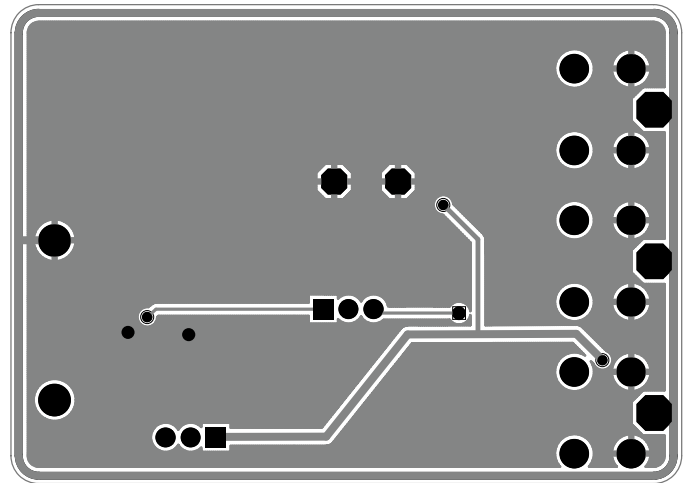

**Figure 6: AHK3292 Evaluation Board  
Bottom Side Layout.**

## AAT3292 EVAL Component Listing

Component	Part Number	Description	Manufacturer
U1	AHK3292IGU	Two Channel LED driver; SOT23-6 package	AnalogicTech
U2	PIC12F675	8-bit CMOS, FLASH-based $\mu$ C; 8-pin PDIP package	Microchip
CYCLE, UP, DOWN	PTS645TL50	Switch Tact, SPST, 5mm	ITT Industries
R1	Chip Resistor	9.53k $\Omega$ , 1%, 1/4W; 0603	Vishay
R5, R6	Chip Resistor	330 $\Omega$ , 1%, 1/4W; 0603	Vishay
R7	Chip Resistor	100k $\Omega$ , 5%, 1/4W; 0603	Vishay
R2, R3, R4	Chip Resistor	1k $\Omega$ , 5%, 1/4W; 0603	Vishay
C1, C2	GRM185R60J105KE21	1 $\mu$ F, 6.3V, X7R, 10%, 0603	Murata
LED1	CMD15-21VGC/TR8	Green LED; 0603	Chicago Miniature Lamp
LED2	CMD15-21SRC/TR8	Red LED; 0603	Chicago Miniature Lamp
J1, J2	PRPN401PAEN	Conn. Header, 2mm zip	Sullins Electronics
JP1, JP2	Chip Resistor	0 $\Omega$ , 5%, 1/4W; 0603	Vishay
JP3	Chip Resistor	0 $\Omega$ , 5%, 1/2W; 0805	Vishay
D1, D2	LW M673	Mini TOPLED White LED; SMD	OSRAM

**Table 4: AHK3292 Evaluation Board Bill of Materials (BOM)**

## Ordering Information

Package	Part Marking <sup>1</sup>	Part Number (Tape and Reel) <sup>2</sup>
SOT23-6	7MXY Y	<b>AHK3292IGU-T1</b>



All AnalogicTech products are offered in Pb-free packaging. The term “Pb-free” means semiconductor products that are in compliance with current RoHS standards, including the requirement that lead not exceed 0.1% by weight in homogeneous materials. For more information, please visit our website at <http://www.analogictech.com/about/quality.aspx>.

## Package Information

### SOT23-6

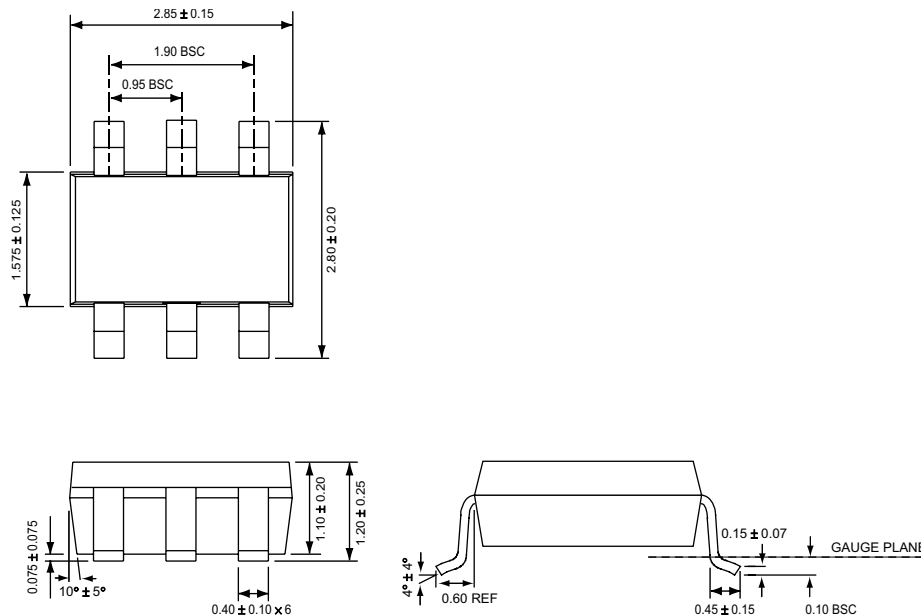

All dimensions in millimeters.

1. XYY = assembly and date code.
2. Sample stock is generally held on part numbers listed in **BOLD**.

**Advanced Analogic Technologies, Inc.**  
 3230 Scott Boulevard, Santa Clara, CA 95054  
 Phone (408) 737-4600  
 Fax (408) 737-4611



© Advanced Analogic Technologies, Inc.  
 AnalogicTech cannot assume responsibility for use of any circuitry other than circuitry entirely embodied in an AnalogicTech product. No circuit patent licenses, copyrights, mask work rights, or other intellectual property rights are implied. AnalogicTech reserves the right to make changes to their products or specifications or to discontinue any product or service without notice. Except as provided in AnalogicTech's terms and conditions of sale, AnalogicTech assumes no liability whatsoever, and AnalogicTech disclaims any express or implied warranty relating to the sale and/or use of AnalogicTech products including liability or warranties relating to fitness for a particular purpose, merchantability, or infringement of any patent, copyright or other intellectual property right. In order to minimize risks associated with the customer's applications, adequate design and operating safeguards must be provided by the customer to minimize inherent or procedural hazards. Testing and other quality control techniques are utilized to the extent AnalogicTech deems necessary to support this warranty. Specific testing of all parameters of each device is not necessarily performed. AnalogicTech and the AnalogicTech logo are trademarks of Advanced Analogic Technologies Incorporated. All other brand and product names appearing in this document are registered trademarks or trademarks of their respective holders.