

### Triple Voltage Monitor with Adjustable Power-On-Reset and Undervoltage/Overvoltage Monitoring Capability

The ISL88021 and ISL88022 family of devices are customizable triple voltage-monitoring supervisors that assert a reset if any of the monitored voltages becomes non-compliant. They offer popular functions such as Power-On-Reset timing control with both RESET and  $\overline{\text{RESET}}$  outputs, Supply Voltage Supervision, both under or overvoltage detection, and Manual Reset assertion. By offering these features in a small 8 Ld MSOP package, the ISL88021 and ISL88022 can lower system cost, reduce board space requirements and increase the reliability of systems.

Applying a voltage to  $V_{DD}$  activates the Power-On-Reset circuit which holds  $\overline{\text{RESET}}$  low for an adjustable period of time. This allows the power supply and system oscillator to stabilize before the processor can execute code.

Low  $V_{DD}$  detection circuitry protects the user's system from low voltage conditions, resetting the system when  $V_{DD}$  falls below its minimum preset voltage threshold  $V_{TH1}$ . Reset remains asserted until  $V_{DD}$  returns to its proper operating level and stabilizes. Two additional voltage monitoring inputs, V2MON (preset) and V3MON (adjustable), monitor other supplies to provide reliable system operation.

The ISL88021 V3MON input monitors for undervoltage (UV) conditions whereas the ISL88022 V3MON input allows monitoring for overvoltage (OV) conditions. The monitored voltage on V3MON on either device is compared via a resistor divider to a 600mV internal reference. Hence, any voltage more or less positive than this reference can be accurately monitored to meet specific system level requirements or to fine-tune the threshold for applications requiring higher precision.

These devices also let users increase the Power-On-Reset time-out delay by connecting a capacitor between  $C_{POR}$  and ground. This lengthens the period of an internal clock counter thereby increasing the time between voltage compliance and reset outputs signaling.

A manual reset input provides debounce circuitry for minimum reset component count.

### Features

- Triple Voltage Monitor and Reset Assertion
- Low  $V_{DD}$  Detection and Reset Assertion
  - Adjustable Reset Threshold Voltages
  - 0.6V  $\pm$ 6mV Over -40°C to +85°C
  - Reset Signal Valid to  $V_{DD} = 1V$
- 140ms Minimum Reset Pulse Delay that is Customizable Using an External Capacitor
- Both RST and  $\overline{\text{RST}}$  Outputs Available
- Undervoltage/Overvoltage Monitoring Capability
- Low 20 $\mu$ A Consumption
- Small 8 Ld MSOP Package
- Pb-Free Plus Anneal Available (RoHS Compliant)

### Applications

- Process Control Systems
- Intelligent Instruments
- Embedded Control Systems
- Computer Systems
- Portable/Battery-Powered Equipment
- Multi-Voltage Systems

### Pinout

**ISL88021, ISL88022**  
**(8 LD MSOP)**  
TOP VIEW

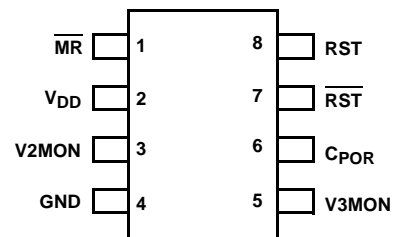

**Ordering Information** (See Notes)

PART NUMBER	PART MARKING	V <sub>DD</sub> V <sub>TRIP1</sub>	V <sub>2MO</sub> V <sub>TRIP2</sub>	V <sub>3MON</sub> TYPE	PACKAGE
ISL88021IU8FAZ	ANM	3.09V	1.69V	UV	8 Ld MSOP
ISL88021IU8FCZ	ANL	3.09V	2.32V	UV	8 Ld MSOP
ISL88021IU8FEZ		3.09V	2.92V	UV	8 Ld MSOP
ISL88021IU8FFZ		3.09V	3.09V	UV	8 Ld MSOP
ISL88021IU8HAZ		4.64V	1.69V	UV	8 Ld MSOP
ISL88021IU8HCZ		4.64V	2.32V	UV	8 Ld MSOP
ISL88021IU8HEZ	ANK	4.64V	2.92V	UV	8 Ld MSOP
ISL88021IU8HFZ	ANJ	4.64V	3.09V	UV	8 Ld MSOP
ISL88022IU8FAZ	ANQ	3.09V	1.69V	OV	8 Ld MSOP
ISL88022IU8FCZ	ANP	3.09V	2.32V	OV	8 Ld MSOP
ISL88022IU8FEZ		3.09V	2.92V	OV	8 Ld MSOP
ISL88022IU8FFZ		3.09V	3.09V	OV	8 Ld MSOP

**Ordering Information** (See Notes) (Continued)

PART NUMBER	PART MARKING	V <sub>DD</sub> V <sub>TRIP1</sub>	V <sub>2MO</sub> V <sub>TRIP2</sub>	V <sub>3MON</sub> TYPE	PACKAGE
ISL88022IU8HAZ		4.64V	1.69V	OV	8 Ld MSOP
ISL88022IU8HCZ		4.64V	2.32V	OV	8 Ld MSOP
ISL88022IU8HEZ	ANO	4.64V	2.92V	OV	8 Ld MSOP
ISL88022IU8HFZ	ANN	4.64V	3.09V	OV	8 Ld MSOP

NOTES:

- Standard versions are shown in bold. For non-standard versions, please contact factory for availability.
- Add "-TK" suffix for Tape and Reel.
- Intersil Pb-free plus anneal products employ special Pb-free material sets; molding compounds/die attach materials and 100% matte tin plate termination finish, which are RoHS compliant and compatible with both SnPb and Pb-free soldering operations. Intersil Pb-free products are MSL classified at Pb-free peak reflow temperatures that meet or exceed the Pb-free requirements of IPC/JEDEC J STD-020.

**Block Diagrams**

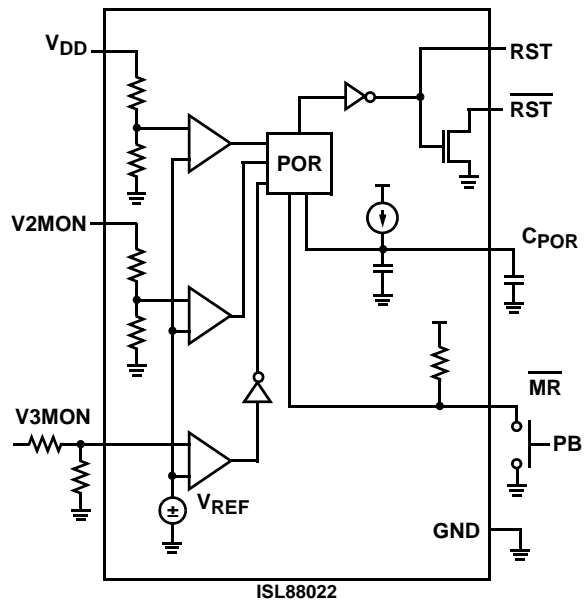
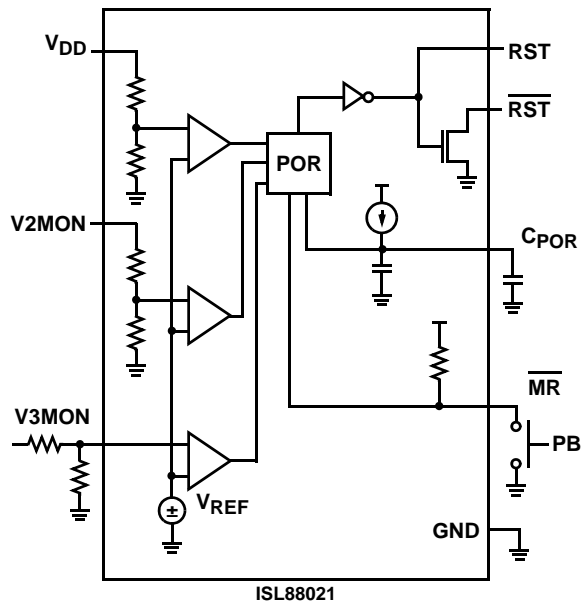

**Pin Descriptions**

ISL88021	ISL88022	NAME	FUNCTION
1	1	$\overline{\text{MR}}$	Active-Low Open Drain Manual Reset Input
2	2	V <sub>DD</sub>	Power Supply Input
3	3	V <sub>2MON</sub>	Second Undervoltage Monitor Input
4	4	GND	Ground
5		V <sub>3MON</sub>	Undervoltage Monitor Input
	5	V <sub>3MON</sub>	Overvoltage Monitor Input
6	6	C <sub>POR</sub>	Set Power-On-Reset Timeout Delay
7	7	$\overline{\text{RST}}$	Active-Low Open Drain Reset Output
8	8	RST	Active-High Push-Pull Reset Output

# ISL88021, ISL88022

## Absolute Maximum Ratings

Temperature Under Bias . . . . . -40 °C to +85 °C  
 Voltage on Any Pin with Respect to GND . . . . . -1.0V to +7V  
 D.C. Output Current . . . . . 5mA

## Recommended Operating Conditions

Industrial . . . . . -40°C to +85°C

## Thermal Information

Thermal Resistance (Typical, Note 1)  $\theta_{JA}$  (°C/W)  
 MSOP Package . . . . . 145  
 Maximum Junction Temperature (Plastic Package) . . . . . +150°C  
 Maximum Storage Temperature Range . . . . . -65°C to +150°C  
 Maximum Lead Temperature (Soldering 10s) . . . . . +300°C  
 (MSOP - Lead Tips Only)

*CAUTION: Stresses above those listed in "Absolute Maximum Ratings" may cause permanent damage to the device. This is a stress only rating and operation of the device at these or any other conditions above those indicated in the operational sections of this specification is not implied.*

### NOTE:

- $\theta_{JA}$  is measured with the component mounted on a high effective thermal conductivity test board in free air. See Tech Brief TB379 for details.

## Electrical Specifications Over the recommended operating conditions unless otherwise specified.

SYMBOL	PARAMETER	TEST CONDITIONS	MIN	TYP	MAX	UNITS
V <sub>DD</sub>	Supply Voltage Range		2.0		5.5	V
I <sub>DD1</sub>	V <sub>DD</sub> Supply Current	V <sub>DD</sub> = 5.0V		12.5	15	μA
I <sub>DD2</sub>	V2MON Input Current	V2MON = 3.3V		5.5	6	μA
I <sub>DDA</sub>	V3MON Input Current	V3MON = 1.0V		19	100	nA
<b>VOLTAGE THRESHOLDS</b>						
V <sub>TH1</sub>	Fixed Voltage Trip Point for V <sub>DD</sub>	ISL88021/22IU8HxZ	4.565	4.649	4.733	V
		ISL88021/22IU8FxZ	3.029	3.085	3.141	V
V <sub>TH1HYST</sub>	Hysteresis of V <sub>TH1</sub>	V <sub>TH1</sub> = 4.64V		46		mV
		V <sub>TH1</sub> = 3.09V		37		mV
V <sub>TH2</sub>	Fixed Voltage Trip Point for V2MON	ISL88021/22IU8xFZ	3.034	3.090	3.146	V
		ISL88021/22IU8xEZ	2.894	2.947	3.000	V
		ISL88021/22IU8xCZ	2.290	2.332	2.374	V
		ISL88021/22IU8xAZ	1.660	1.690	1.720	V
V <sub>TH2HYST</sub>	Hysteresis of V <sub>TH2</sub>	V <sub>TH2</sub> = 3.09V		37		mV
		V <sub>TH2</sub> = 2.92V		29		mV
		V <sub>TH2</sub> = 2.32V		23		mV
		V <sub>TH2</sub> = 2.19V		22		mV
		V <sub>TH2</sub> = 1.69V		17		mV
V <sub>TH3</sub>	V3MON Threshold Voltage	V <sub>TH</sub> for V3MON on ISL88021	0.594	0.605	0.616	V
		V <sub>TH</sub> for V3MON on ISL88022	0.587	0.595	0.603	V
V <sub>REFHYST</sub>	Hysteresis Voltage			3		mV
<b>RESET</b>						
V <sub>OL</sub>	Reset Output Voltage Low	V <sub>DD</sub> ≥ 3.3V, Sinking 2.5mA		0.05	0.40	V
		V <sub>DD</sub> < 3.3V, Sinking 1.5mA		0.05	0.40	V
V <sub>OH</sub>	RST Output Voltage High	V <sub>DD</sub> ≥ 3.3V, Sourcing 2.5mA	V <sub>DD</sub> -0.6	V <sub>DD</sub> -0.4		V
		V <sub>DD</sub> < 3.3V, Sourcing 1.5mA	V <sub>DD</sub> -0.6	V <sub>DD</sub> -0.4		V
t <sub>RPD</sub>	V <sub>TH</sub> to Reset Asserted Delay			10		μs
t <sub>POR</sub>	POR Timeout Delay	C <sub>POR</sub> is open	140	200		ms
C <sub>LOAD</sub>	Load Capacitance on Reset Pins			5		pF

**Electrical Specifications** Over the recommended operating conditions unless otherwise specified. (Continued)

SYMBOL	PARAMETER	TEST CONDITIONS	MIN	TYP	MAX	UNITS
<b>MANUAL RESET</b>						
V <sub>MRL</sub>	$\overline{\text{MR}}$ Input Voltage Low				0.8	V
V <sub>MRH</sub>	$\overline{\text{MR}}$ Input Voltage High		V <sub>DD</sub> -0.6			V
t <sub>MR</sub>	$\overline{\text{MR}}$ Minimum Pulse Width		550			ns
R <sub>PU</sub>	Internal Pull-Up Resistor			20		kΩ

**Functional Description**

The ISL88021 and ISL88022 devices incorporate such features as Power-On-Reset control, Supply Voltage Supervision, Undervoltage or Overvoltage Monitoring, and Manual Reset Assertion.

The ISL88021 and ISL88022 devices provide common preset threshold voltages on both V<sub>DD</sub> and V2MON and for an optional resistor divider network on V3MON to provide custom voltage monitoring of voltages greater than 0.6V. An optional capacitor can be connected between the C<sub>POR</sub> pin and GND to increase the nominal 200ms t<sub>POR</sub> delay. Figure 7 illustrates operational functionality with a timing diagram.

**Voltage Monitoring**

During normal operation, the ISL88021 and ISL88022 monitor the voltage levels on V<sub>DD</sub>, V2MON and V3MON. The ISL88021 asserts reset if any one of these voltages fall below their respective voltage trip points and in the case of ISL88022 above the voltage trip point on the V3MON input. The reset signal effectively prevents the microprocessor from operating during a power failure, brownout or over voltage condition. This signal remains active until all monitored voltages meet all voltage threshold requirements for the reset time delay period t<sub>POR</sub>. Note that both RESET and  $\overline{\text{RESET}}$  signals are provided for design flexibility. Figure 1 illustrates the V<sub>DD</sub>, V2MON and V3MON input threshold voltages for the various available options.

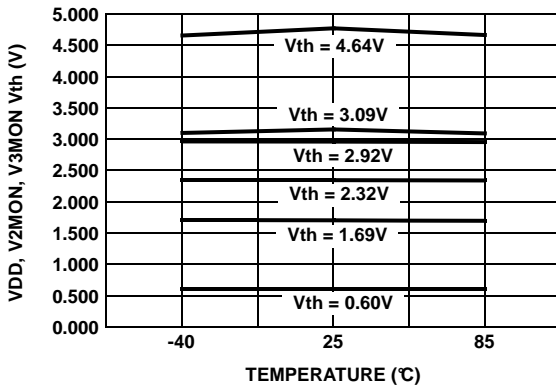

FIGURE 1. VDD, V2MON, V3MON VTH vs TEMP

**Power-On-Reset (POR)**

Applying power to the ISL88021 and ISL88022 devices activates a POR circuit which holds the  $\overline{\text{RESET}}$  pin low once V<sub>DD</sub> > 1V. This signal provides several benefits:

- It prevents the system microprocessor from starting to operate with insufficient voltage.
- It prevents the processor from operating prior to stabilization of the oscillator.
- It ensures that the monitored device is held out of operation until internal registers are properly loaded.
- It allows time for an FPGA to download its configuration prior to initialization of the circuit.

When all of the monitored voltages meet their respective input voltage requirements for the specified reset timeout delay t<sub>POR</sub>, the POR circuit simultaneously pulls the RST output low and releases the  $\overline{\text{RST}}$  output to allow the system to begin operation.

**Adjusting t<sub>POR</sub>**

On the ISL88021 and ISL88022, users can adjust the Power-On-Reset timeout delay (t<sub>POR</sub>) to many times the nominal t<sub>POR</sub>. Figure 2 illustrates the effect of capacitance on the C<sub>POR</sub> pin to ground, showing changing t<sub>POR</sub> with a graph normalized to 175ms for an open C<sub>POR</sub> pin. The maximum recommended capacitance that should be placed on the C<sub>POR</sub> pin is 50pF. **NOTE:** Care should be taken in PCB layout and capacitor placement in order to eliminate stray capacitance as much as possible, which contributes to t<sub>POR</sub> error.

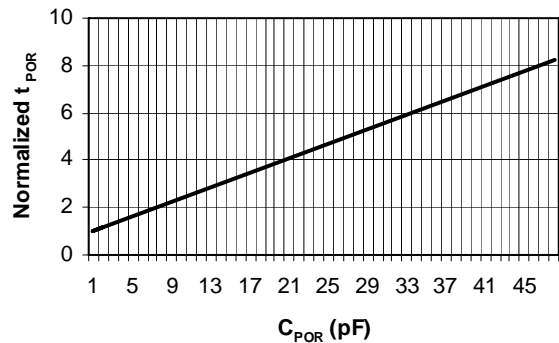

FIGURE 2. NORMALIZED t<sub>POR</sub> vs C<sub>POR</sub> GRAPH

**Manual Reset**

The manual reset input ( $\overline{MR}$ ) allows the user to trigger a reset by using a push-button switch or by signaling that pin low. The  $\overline{MR}$  input is an active low debounced input. By connecting a push-button directly from  $\overline{MR}$  to ground, the designer adds manual system reset capability. Reset is asserted if the  $\overline{MR}$  pin is pulled low to less than 100mV for 1 $\mu$ s or longer while the push-button is closed or a reset is signaled. After  $\overline{MR}$  is released, the reset outputs remain asserted for  $t_{POR}$ .  $\overline{MR}$  input has an internal 20k $\Omega$  pull up resistor provided.

Figure 3 illustrates a typical application diagram for either IC showing both reset outputs being used along with both a manual and signalled reset configuration. The  $V_{DD}$  and  $V2MON$  thresholds are preset whereas the  $V3MON$  is capable of UV (ISL88021) or OV (ISL88022) monitoring of a voltage greater than or less than 0.6V, respectively.

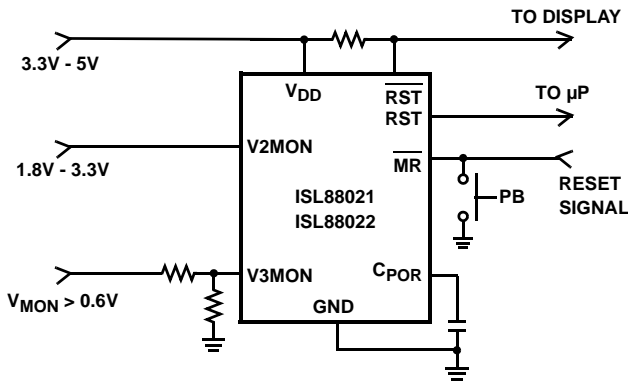

FIGURE 3. TYPICAL APPLICATION DIAGRAM

**Application Considerations**

Follow good decoupling practices to prevent transients from causing unwanted reset signaling due to switching noises and short duration droops.

When using the  $C_{POR}$  pin, reduce layout stray capacitance on this pin to minimize effect on  $t_{POR}$  timing. If no PCB  $C_{POR}$  pad is patterned, the  $t_{POR}$  can be 160ms.

**Using the ISL88021\_22EVAL1 Platform**

The ISL88021\_22EVAL1 board is designed to provide both immediate functional assessment and flexibility to the user. Both ICs are the 'HF' variant having a  $V_{DD}$   $V_{th}$  of 4.64V, a  $V2MON$   $V_{th}$  of 3.09V and  $V3MON$   $V_{th}$  of 0.6V. The top IC position is the ISL88021 and is configured to monitor for undervoltage (UV) compliance of a 5V, 3.3V and a 2.5V and signaling the RESET and  $\overline{RESET}$  outputs. The bottom position is the ISL88022 variant, which is configured to measure a 3.3V overvoltage (OV) in addition to UV on both the 5V and 3.3V supplies. RESET and  $\overline{RESET}$  is asserted for at least  $t_{POR}$  when these voltage go out of range. In both cases  $V3MON$  interfaces with the monitored supply via a simple resistor divider for comparison to the internal 0.6V reference. A Manual Reset ( $\overline{MR}$ ) input is provided on both ICs and is invoked by pulling this input LOW.

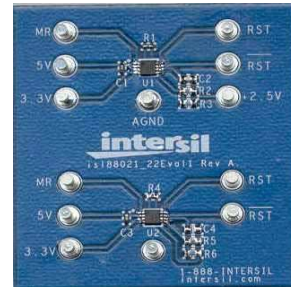
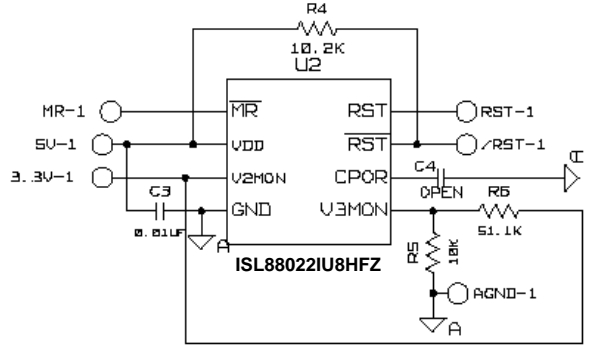
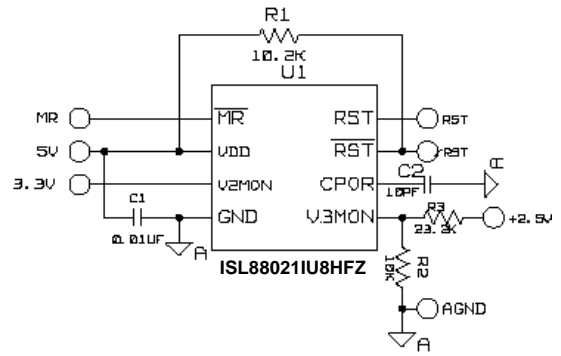

FIGURE 4. ISL88021\_22EVAL1 SCHEMATIC AND PHOTO

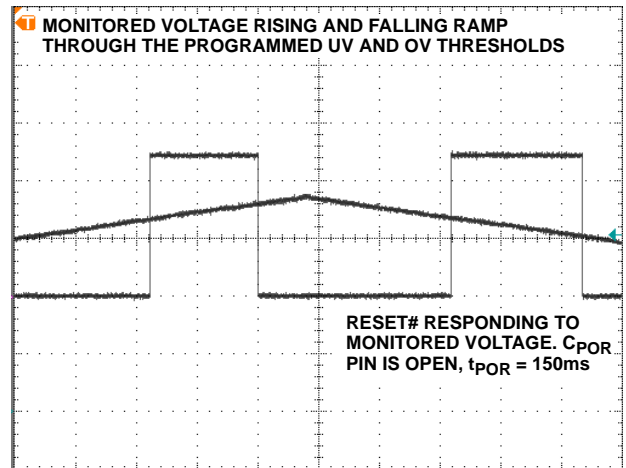

FIGURE 5. ISL88022EVAL1 3.3V UV AND OV DETECTION

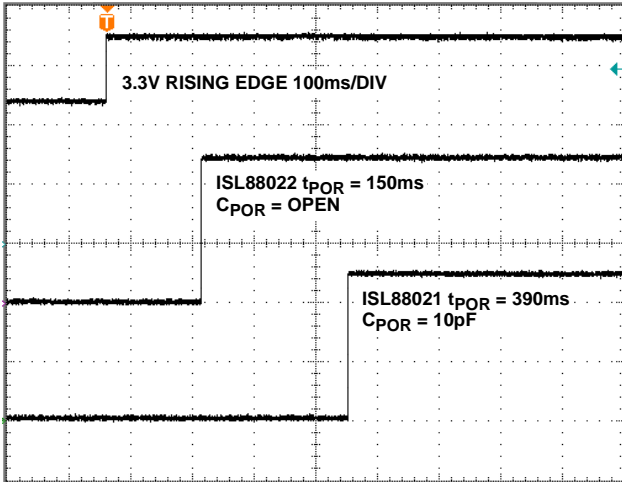

FIGURE 6. ISL88021\_22EVAL1  $t_{POR}$  COMPARISON

**Operational Timing Diagrams**

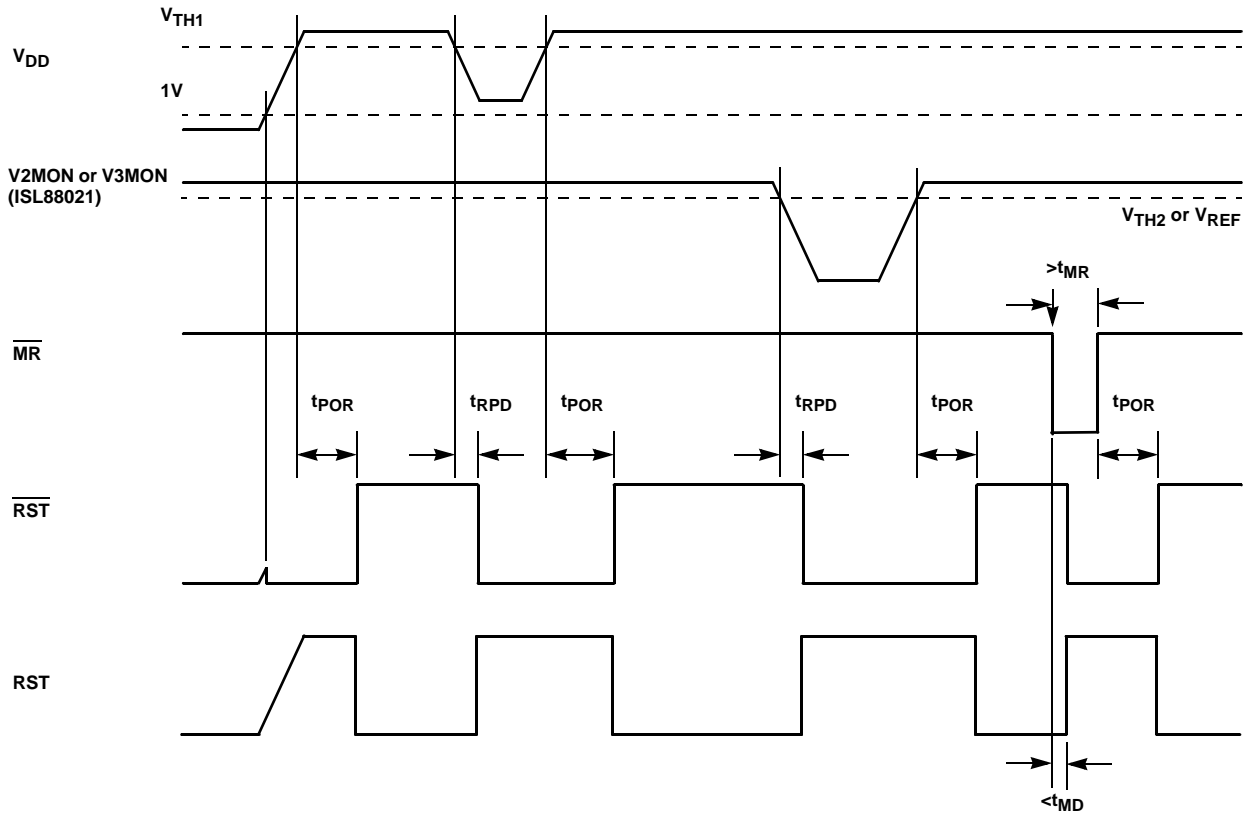
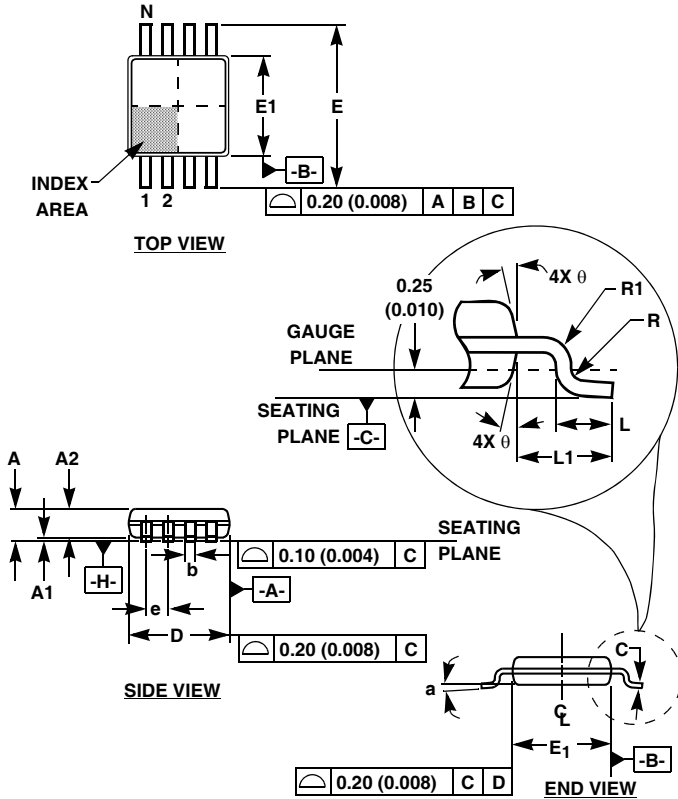

FIGURE 7. ISL88021 AND ISL88022 TIMING DIAGRAM

Mini Small Outline Plastic Packages (MSOP)



M8.118 (JEDEC MO-187AA)  
8 LEAD MINI SMALL OUTLINE PLASTIC PACKAGE

SYMBOL	INCHES		MILLIMETERS		NOTES
	MIN	MAX	MIN	MAX	
A	0.037	0.043	0.94	1.10	-
A1	0.002	0.006	0.05	0.15	-
A2	0.030	0.037	0.75	0.95	-
b	0.010	0.014	0.25	0.36	9
c	0.004	0.008	0.09	0.20	-
D	0.116	0.120	2.95	3.05	3
E1	0.116	0.120	2.95	3.05	4
e	0.026 BSC		0.65 BSC		-
E	0.187	0.199	4.75	5.05	-
L	0.016	0.028	0.40	0.70	6
L1	0.037 REF		0.95 REF		-
N	8		8		7
R	0.003	-	0.07	-	-
R1	0.003	-	0.07	-	-
$\theta$	5°	15°	5°	15°	-
$\alpha$	0°	6°	0°	6°	-

Rev. 2 01/03

NOTES:

- These package dimensions are within allowable dimensions of JEDEC MO-187BA.
- Dimensioning and tolerancing per ANSI Y14.5M-1994.
- Dimension "D" does not include mold flash, protrusions or gate burrs and are measured at Datum Plane. Mold flash, protrusion and gate burrs shall not exceed 0.15mm (0.006 inch) per side.
- Dimension "E1" does not include interlead flash or protrusions and are measured at Datum Plane.  $-H-$  Interlead flash and protrusions shall not exceed 0.15mm (0.006 inch) per side.
- Formed leads shall be planar with respect to one another within 0.10mm (0.004) at seating Plane.
- "L" is the length of terminal for soldering to a substrate.
- "N" is the number of terminal positions.
- Terminal numbers are shown for reference only.
- Dimension "b" does not include dambar protrusion. Allowable dambar protrusion shall be 0.08mm (0.003 inch) total in excess of "b" dimension at maximum material condition. Minimum space between protrusion and adjacent lead is 0.07mm (0.0027 inch).
- Datums  $-A-$  and  $-B-$  to be determined at Datum plane  $-H-$ .
- Controlling dimension: MILLIMETER. Converted inch dimensions are for reference only.

All Intersil U.S. products are manufactured, assembled and tested utilizing ISO9000 quality systems.  
Intersil Corporation's quality certifications can be viewed at [www.intersil.com/design/quality](http://www.intersil.com/design/quality)

*Intersil products are sold by description only. Intersil Corporation reserves the right to make changes in circuit design, software and/or specifications at any time without notice. Accordingly, the reader is cautioned to verify that data sheets are current before placing orders. Information furnished by Intersil is believed to be accurate and reliable. However, no responsibility is assumed by Intersil or its subsidiaries for its use; nor for any infringements of patents or other rights of third parties which may result from its use. No license is granted by implication or otherwise under any patent or patent rights of Intersil or its subsidiaries.*

For information regarding Intersil Corporation and its products, see [www.intersil.com](http://www.intersil.com)