

**Single Digitally-Controlled (XDCP™) Potentiometer**

The X9110 integrates a single digitally controlled potentiometer (XDCP) on a monolithic CMOS integrated circuit.

The digital controlled potentiometer is implemented using 1023 resistive elements in a series array. Between each element are tap points connected to the wiper terminal through switches. The position of the wiper on the array is controlled by the user through the SPI bus interface. The potentiometer has associated with it a volatile Wiper Counter Register (WCR) and four non-volatile Data Registers that can be directly written to and read by the user. The contents of the WCR controls the position of the wiper on the resistor array through the switches. Power-up recalls the contents of the default data register (DR0) to the WCR.

The XDCP can be used as a three-terminal potentiometer or as a two terminal variable resistor in a wide variety of applications including control, parameter adjustments, and signal processing.

**Features**

- 1024 Resistor Taps – 10-Bit Resolution
- SPI Serial Interface for write,read, and transfer operations of the potentiometer
- Wiper Resistance, 40Ω Typical @ 5V
- Four Non-Volatile Data Registers
- Non-Volatile Storage of Multiple Wiper Positions
- Power-on Recall. Loads Saved Wiper Position on Power-up
- Standby Current < 3μA Max
- System V<sub>CC</sub>: 2.7V to 5.5V Operation
- Analog V<sub>+</sub>/V<sub>-</sub>: -5V to +5V
- 100kΩ End to End Resistance
- 100 yr. Data Retention
- Endurance: 100, 000 Data Changes Per Bit Per Register
- 14 Ld TSSOP
- Dual Supply Version of the X9111
- Low Power CMOS
- Pb-Free Available (RoHS Compliant)

**Pinout**

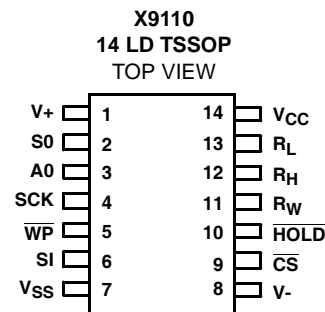

**Functional Diagram**

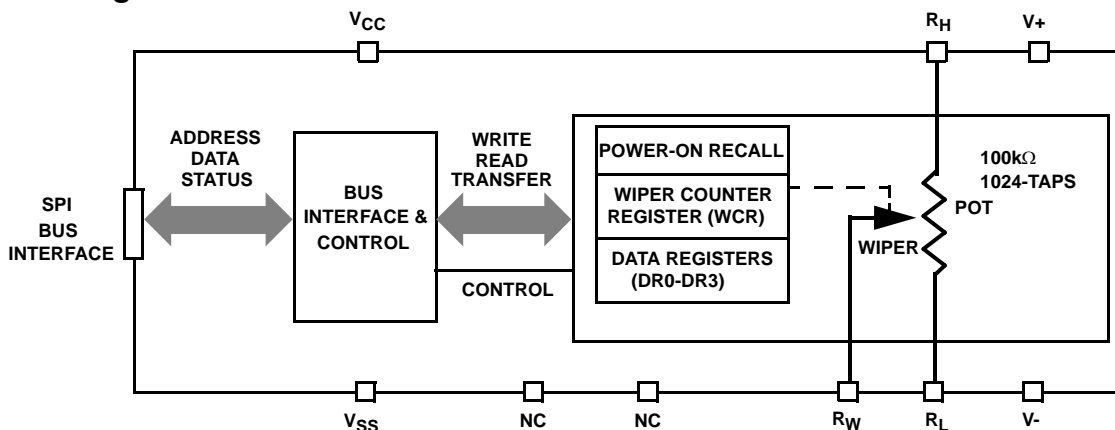

**Ordering Information**

PART NUMBER	PART MARKING	VCC LIMITS (V)	POTENTIOMETER RANGE (kΩ)	TEMP RANGE (°C)	PACKAGE	PKG. DWG. #
X9110TV14	X9110TV	5 ±10	100	0 to +70	14 Ld TSSOP	M14.173
X9110TV14Z* (Note)	X9110TV Z			0 to +70	14 Ld TSSOP (Pb-free)	M14.173
X9110TV14I	X9110TV I			-40 to +85	14 Ld TSSOP	M14.173
X9110TV14IZ (Note)	X9110TV Z I			-40 to +85	14 Ld TSSOP (Pb-free)	M14.173
X9110TV14-2.7	X9110TV F	2.7 to 5.5		0 to +70	14 Ld TSSOP	M14.173
X9110TV14Z-2.7 (Note)	X9110TV Z F			0 to +70	14 Ld TSSOP (Pb-free)	M14.173
X9110TV14I-2.7	X9110TV G			-40 to +85	14 Ld TSSOP	M14.173
X9110TV14IZ-2.7* (Note)	X9110TV Z G			-40 to +85	14 Ld TSSOP (Pb-free)	M14.173

\*Please refer to TB347 for details on reel specifications.

NOTE: These Intersil Pb-free plastic packaged products employ special Pb-free material sets; molding compounds/die attach materials and 100% matte tin plate PLUS ANNEAL - e3 termination finish, which is RoHS compliant and compatible with both SnPb and Pb-free soldering operations. Intersil Pb-free products are MSL classified at Pb-free peak reflow temperatures that meet or exceed the Pb-free requirements of IPC/JEDEC J STD-020.

**Detailed Functional Diagram**

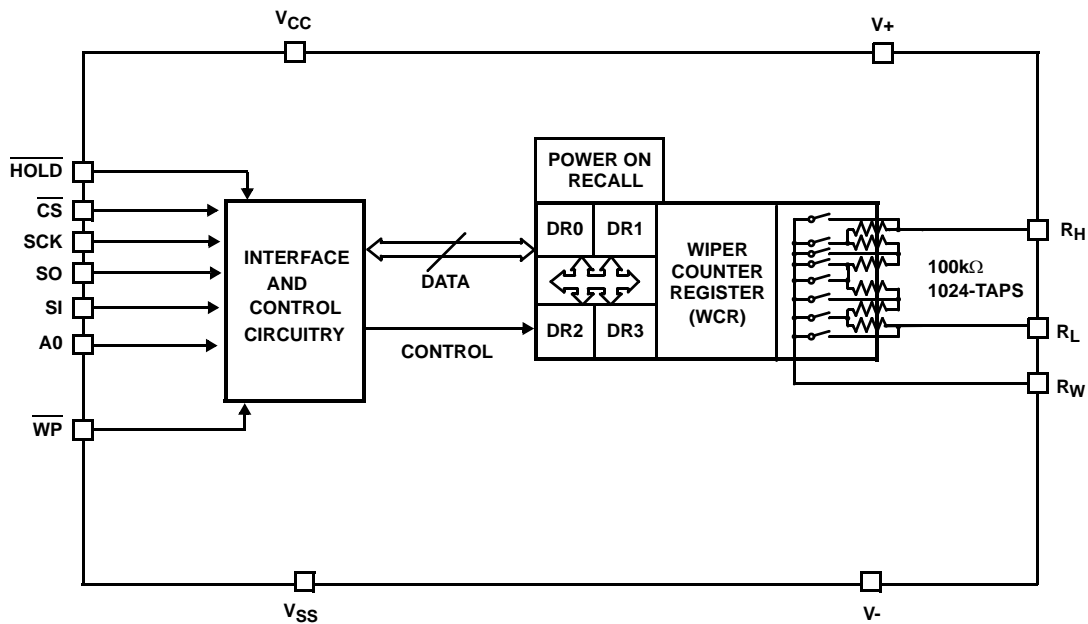

## Circuit Level Applications

- Vary the gain of a voltage amplifier
- Provide programmable dc reference voltages for comparators and detectors
- Control the volume in audio circuits
- Trim out the offset voltage error in a voltage amplifier circuit
- Set the output voltage of a voltage regulator
- Trim the resistance in Wheatstone bridge circuits
- Control the gain, characteristic frequency and Q-factor in filter circuits
- Set the scale factor and zero point in sensor signal conditioning circuits
- Vary the frequency and duty cycle of timer ICs
- Vary the dc biasing of a pin diode attenuator in RF circuits
- Provide a control variable (I, V, or R) in feedback circuits

## System Level Applications

- Adjust the contrast in LCD displays
- Control the power level of LED transmitters in communication systems
- Set and regulate the DC biasing point in an RF power amplifier in wireless systems
- Control the gain in audio and home entertainment systems
- Provide the variable DC bias for tuners in RF wireless systems
- Set the operating points in temperature control systems
- Control the operating point for sensors in industrial systems
- Trim offset and gain errors in artificial intelligent systems

## Pin Descriptions

PIN (TSSOP)	SYMBOL	FUNCTION
1	V+	Analog Supply Voltage
2	SO	Serial Data Output
3	A0	Device Address
4	SCK	Serial Clock
5	$\overline{\text{WP}}$	Hardware Write Protect
6	SI	Serial Data Input
7	V <sub>SS</sub>	System Ground
8	V-	Analog Supply Voltage
9	$\overline{\text{CS}}$	Chip Select
10	$\overline{\text{HOLD}}$	Device Select. Pause the Serial Bus

## Pin Descriptions (Continued)

PIN (TSSOP)	SYMBOL	FUNCTION
11	R <sub>W</sub>	Wiper Terminal of the Potentiometer
12	R <sub>H</sub>	High Terminal of the Potentiometer
13	R <sub>L</sub>	Low Terminal of the Potentiometer
14	V <sub>CC</sub>	System Supply Voltage

### Bus Interface Pins

#### SERIAL OUTPUT (SO)

SO is a serial data output pin. During a read cycle, data is shifted out on this pin. Data is clocked out on the falling edge of the serial clock.

#### SERIAL INPUT (SI)

SI is the serial data input pin. All opcodes, byte addresses and data to be written to the pots and pot registers are input on this pin. Data is latched by the rising edge of the serial clock.

#### SERIAL CLOCK (SCK)

The SCK input is used to clock data into and out of the X9110.

#### HOLD ( $\overline{\text{HOLD}}$ )

$\overline{\text{HOLD}}$  is used in conjunction with the  $\overline{\text{CS}}$  pin to select the device. Once the part is selected and a serial sequence is underway,  $\overline{\text{HOLD}}$  may be used to pause the serial communication with the controller without resetting the serial sequence. To pause,  $\overline{\text{HOLD}}$  must be brought LOW while SCK is LOW. To resume communication,  $\overline{\text{HOLD}}$  is brought HIGH, again while SCK is LOW. If the pause feature is not used,  $\overline{\text{HOLD}}$  should be held HIGH at all times.

#### DEVICE ADDRESS (A0)

The address input is used to set the 8-bit slave address. A match in the slave address serial data stream A0 must be made with the address input (A0) in order to initiate communication with the X9110.

#### CHIP SELECT ( $\overline{\text{CS}}$ )

When  $\overline{\text{CS}}$  is HIGH, the X9110 is deselected and the SO pin is at high impedance, and (unless an internal write cycle is underway) the device will be in the standby state.  $\overline{\text{CS}}$  LOW enables the X9110, placing it in the active power mode. It should be noted that after a power-up, a HIGH to LOW transition on  $\overline{\text{CS}}$  is required prior to the start of any operation.

#### HARDWARE WRITE PROTECT INPUT ( $\overline{\text{WP}}$ )

The  $\overline{\text{WP}}$  pin when LOW prevents nonvolatile writes to the Data Registers.

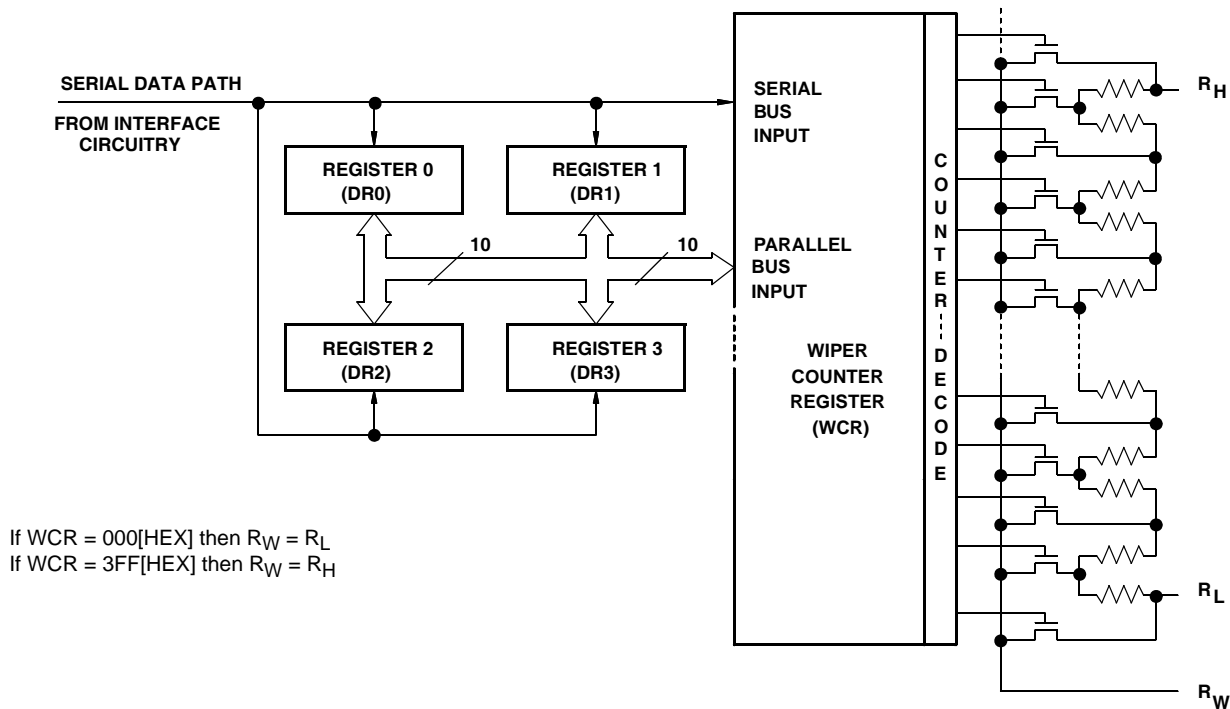

FIGURE 1. DETAILED POTENTIOMETER BLOCK DIAGRAM

### Potentiometer Pins

#### $R_H$ , $R_L$

The  $R_H$  and  $R_L$  pins are equivalent to the terminal connections on a mechanical potentiometer.

#### $R_W$

The wiper pin are equivalent to the wiper terminal of a mechanical potentiometer.

### Bias Supply Pins

#### SYSTEM SUPPLY VOLTAGE ( $V_{CC}$ ) AND SUPPLY GROUND ( $V_{SS}$ )

The  $V_{CC}$  pin is the system supply voltage. The  $V_{SS}$  pin is the system ground.

#### ANALOG SUPPLY VOLTAGES ( $V+$ AND $V-$ )

These supplies are the analog voltage supplies for the potentiometer. The  $V+$  supply is tied to the wiper switches while the  $V-$  supply is used to bias the switches and the internal P+ substrate of the integrated circuit. Both of these supplies set the voltage limits of the potentiometer.

## Principles Of Operation

### Device Description

#### SERIAL INTERFACE

The X9110 supports the SPI interface hardware conventions. The device is accessed via the SI input with data clocked-in

on the rising SCK.  $\overline{CS}$  must be LOW and the  $\overline{HOLD}$  and  $\overline{WP}$  pins must be HIGH during the entire operation.

The SO and SI pins can be connected together, since they have three state outputs. This can help to reduce system pin count.

### ARRAY DESCRIPTION

The X9110 is comprised of a resistor array (Figure 1). The array contains the equivalent of 1023 discrete resistive segments that are connected in series. The physical ends of each array are equivalent to the fixed terminals of a mechanical potentiometer ( $R_H$  and  $R_L$  inputs).

At both ends of each array and between each resistor segment is a CMOS switch connected to the wiper ( $R_W$ ) output. Within the individual array only one switch may be turned on at a time.

These switches are controlled by a Wiper Counter Register (WCR). The 10-bits of the WCR (WCR[9:0]) are decoded to select, and enable, one of 1024 switches.

#### WIPER COUNTER REGISTER (WCR)

The X9110 contains a Wiper Counter Register (see Table 1) for the XDCP potentiometer. The WCR is equivalent to a serial-in, parallel-out register/counter with its outputs decoded to select one of 1024 switches along its resistor array. The contents of the WCR can be altered in one of three ways: (1) it may be written directly by the host via the write Wiper Counter Register instruction (serial load); (2) it

may be written indirectly by transferring the contents of one of four associated Data Registers via the XFR Data Register; (3) it is loaded with the contents of its data register zero (DR0) upon power-up.

The Wiper Counter Register is a volatile register; that is, its contents are lost when the X9110 is powered-down. Although the register is automatically loaded with the value in DR0 upon power-up, this may be different from the value present at power-down. Power-up guidelines are recommended to ensure proper loadings of the DR0 value into the WCR.

**DATA REGISTERS (DR)**

The potentiometer has four 10-bit non-volatile Data Registers. These can be read or written directly by the host. Data can also be transferred between any of the four Data Registers and the Wiper Counter Register. All operations changing data in one of the Data Registers is a nonvolatile operation and will take a maximum of 10ms.

If the application does not require storage of multiple settings for the potentiometer, the Data Registers can be used as regular memory locations for system parameters or user preference data.

DR[9:0] is used to store one of the 1024 wiper position (0~1023) (see Table 2).

**STATUS REGISTER (SR)**

This 1-bit status register is used to store the system status (see Table 3).

WIP: Write In Progress status bit, read only.

- When WIP = 1, indicates that high-voltage write cycle is in progress.
- When WIP=0, indicates that no high-voltage write cycle is in progress.

**TABLE 1. WIPER CONTROL REGISTER, WCR (10-BIT), WCR9–WCR0:** Used To Store The Current Wiper Position (Volatile, V)

WCR9	WCR8	WCR7	WCR6	WCR5	WCR4	WCR3	WCR2	WCR1	WCR0
V	V	V	V	V	V	V	V	V	V
(MSB)									(LSB)

**TABLE 2. DATA REGISTER, DR (10-BIT), BIT 9–BIT 0:** Used to store wiper positions or data (Non-Volatile, NV)

BIT 9	BIT 8	BIT 7	BIT 6	BIT 5	BIT 4	BIT 3	BIT 2	BIT 1	BIT 0
NV	NV	NV	NV	NV	NV	NV	NV	NV	NV
MSB									LSB

**TABLE 3. STATUS REGISTER, SR (1-BIT)**

WIP
(LSB)

TABLE 4. IDENTIFICATION BYTE FORMAT

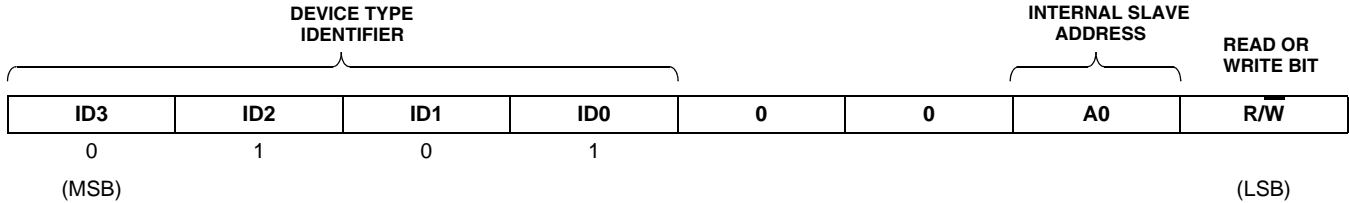
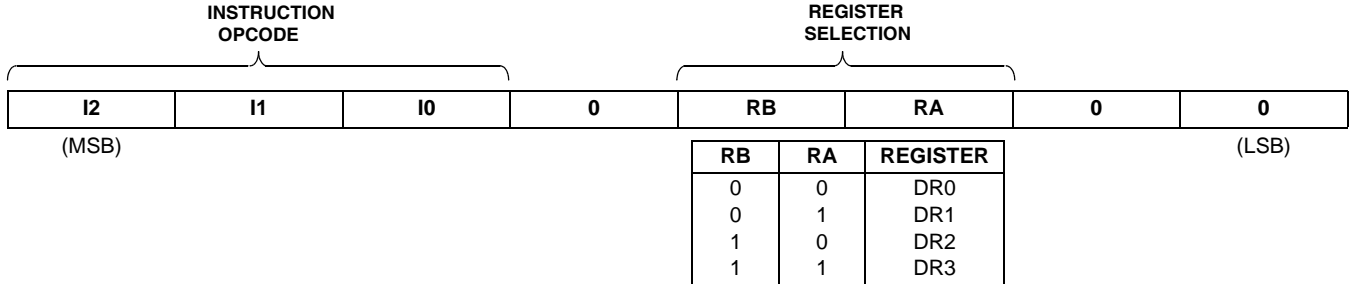

TABLE 5. INSTRUCTION BYTE FORMAT



**Device Instructions**

**Identification Byte (ID and A)**

The first byte sent to the X9110 from the host, following a  $\overline{CS}$  going HIGH to LOW, is called the Identification Byte. The most significant four bits of the slave address are a device type identifier. The ID[3:0] bits is the device ID for the X9110; this is fixed as 0101[B] (refer to Table 4).

The A0 bit in the ID byte is the internal slave address. The physical device address is defined by the state of the A0 input pin. The slave address is externally specified by the user. The X9110 compares the serial data stream with the address input state; a successful compare of the address bit is required for the X9110 to successfully continue the command sequence. Only the device whose slave address matches the incoming device address sent by the master executes the instruction. The A0 input can be actively driven by CMOS input signals or tied to  $V_{CC}$  or  $V_{SS}$ . The  $R/\overline{W}$  bit is used to set the device to either read or write mode.

**Instruction Byte and Register Selection**

The next byte sent to the X9110 contains the instruction and register pointer information. The three most significant bits are used provide the instruction opcode (I[2:0]). The RB and RA bits point to one of the four registers. The format is shown in Table 5.

Five of the seven instructions are four bytes in length. These instructions are:

- **Read Wiper Counter Register** – read the current wiper position of the selected pot
- **Write Wiper Counter Register** – change current wiper position of the selected pot
- **Read Data Register** – read the contents of the selected data register

- **Write Data Register** – write a new value to the selected data register
- **Read Status** – This command returns the contents of the WIP bit which indicates if the internal write cycle is in progress

The basic sequence of the four byte instructions is illustrated in Figure 3. These four-byte instructions exchange data between the WCR and one of the Data Registers. A transfer from a Data Register to a WCR is essentially a write to a static RAM, with the static RAM controlling the wiper position. The response of the wiper to this action will be delayed by  $t_{WRL}$ . A transfer from the WCR (current wiper position), to a Data Register is a write to nonvolatile memory and takes a minimum of  $t_{WR}$  to complete. The transfer can occur between the potentiometer and one of its associated registers. The Read Status Register instruction is the only unique format (see Figure 4).

Two instructions require a two-byte sequence to complete (See Figure 2). These instructions transfer data between the host and the X9110; either between the host and one of the Data Registers or directly between the host and the Wiper Counter Register. These instructions are:

- **XFR Data Register to Wiper Counter Register** – This transfers the contents of one specified Data Register to the associated Wiper Counter Register
- **XFR Wiper Counter Register to Data Register** – This transfers the contents of the specified Wiper Counter Register to the specified associated Data Register

See Instruction format for more details.

**Write in Process (WIP bit)**

The contents of the Data Registers are saved to nonvolatile memory when the  $\overline{CS}$  pin goes from LOW to HIGH after a complete write sequence is received by the device. The progress of this internal write operation can be monitored by a Write In Process bit (WIP). The WIP bit is read with a Read Status command (See Figure 4).

**Power-up and Down Requirements**

At all times, the  $V+$  voltage must be greater than or equal to the voltage at  $R_H$  or  $R_L$ , and the voltage at  $R_H$  or  $R_L$  must be greater than or equal to the voltage at  $V-$ . During power-up and power-down,  $V_{CC}$ ,  $V+$ , and  $V-$  must reach their final values within 1msec of each other.

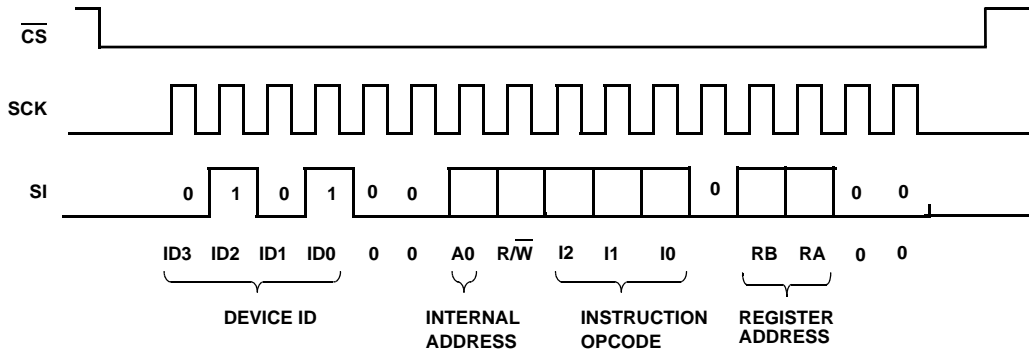

FIGURE 2. TWO-BYTE INSTRUCTION SEQUENCE

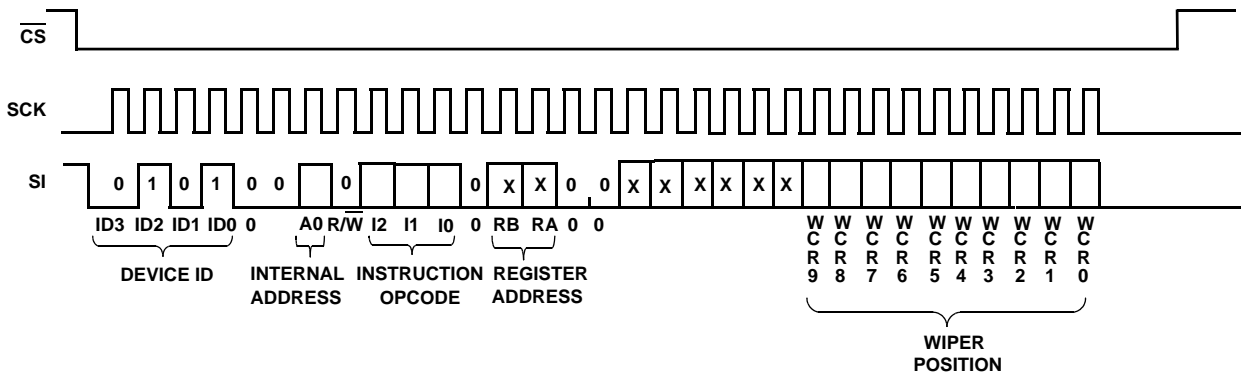

FIGURE 3. FOUR-BYTE INSTRUCTION SEQUENCE (WRITE OR READ FOR WCR OR DATA REGISTERS)

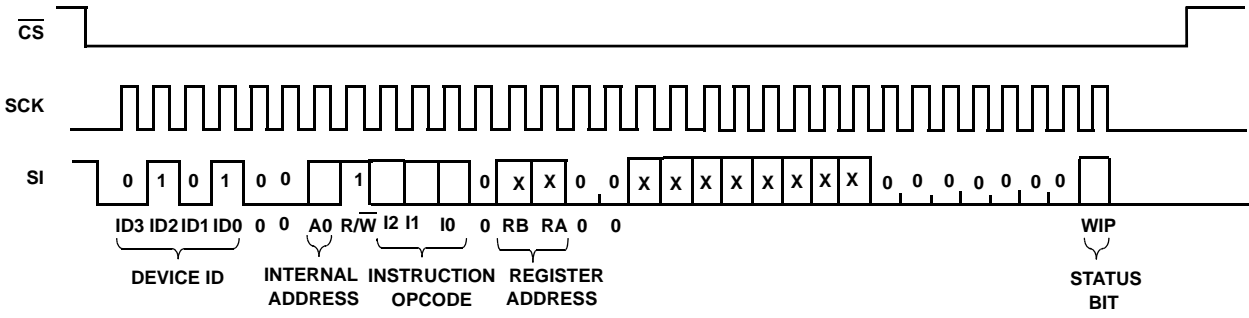

FIGURE 4. FOUR-BYTE INSTRUCTION SEQUENCE (READ STATUS REGISTERS)

TABLE 6. INSTRUCTION SET

INSTRUCTION	INSTRUCTION SET									OPERATION	
	R/W	I <sub>2</sub>	I <sub>1</sub>	I <sub>0</sub>	0	RB	RA	0	0		
Read Wiper Counter Register	1	1	0	0	0	0	0	0	0	0	Read the contents of the Wiper Counter Register
Write Wiper Counter Register	0	1	0	1	0	0	0	0	0	0	Write new value to the Wiper Counter Register
Read Data Register	1	1	0	1	0	1/0	1/0	0	0	0	Read the contents of the Data Register pointed to RB-RA
Write Data Register	0	1	1	0	0	1/0	1/0	0	0	0	Write new value to the Data Register pointed to RB-RA
XFR Data Register to Wiper Counter Register	1	1	1	0	0	1/0	1/0	0	0	0	Transfer the contents of the Data Register pointed to by RB-RA to the Wiper Counter Register
XFR Wiper Counter Register to Data Register	0	1	1	1	0	1/0	1/0	0	0	0	Transfer the contents of the Wiper Counter Register to the Data Register pointed to by RB-RA
Read Status (WIP bit)	1	0	1	0	0	0	0	0	0	1	Read the status of the internal write cycle, by checking the WIP bit (read status register).

NOTE: 1/0 = data is one or zero

**Instruction Format**

**Read Wiper Counter Register (WCR)**

CS Falling Edge	Device Type Identifier		Device Addresses		Instruction Opcode		Register Addresses		Wiper Position (Sent by X9110 on SO)						Wiper Position (sent by X9110 on SO)						CS Rising Edge												
	0	1	0	1	0	0	A0	R/W = 1	1	0	0	0	0	0	0	0	X	X	X	X		X	X	WCR9	WCR8	WCR7	WCR6	WCR5	WCR4	WCR3	WCR2	WCR1	WCR0
	0	1	0	1	0	0	A0	R/W = 1	1	0	0	0	0	0	0	0	X	X	X	X	X	X	WCR9	WCR8	WCR7	WCR6	WCR5	WCR4	WCR3	WCR2	WCR1	WCR0	

**Write Wiper Counter Register (WCR)**

CS Falling Edge	Device Type Identifier		Device Addresses		Instruction Opcode		Register Addresses		Wiper Position (Sent by Master on SI)						Wiper Position (Sent by Master on SI)						CS Rising Edge												
	0	1	0	1	0	0	A0	R/W = 0	1	0	1	0	0	0	0	0	X	X	X	X		X	X	WCR9	WCR8	WCR7	WCR6	WCR5	WCR4	WCR3	WCR2	WCR1	WCR0
	0	1	0	1	0	0	A0	R/W = 0	1	0	1	0	0	0	0	0	X	X	X	X	X	X	WCR9	WCR8	WCR7	WCR6	WCR5	WCR4	WCR3	WCR2	WCR1	WCR0	

**Read Data Register (DR)**

CS Falling Edge	Device Type Identifier		Device Addresses		Instruction Opcode		Register Addresses		Wiper Position (Sent by X9110 on SO)						Wiper Position (sent by X9110 on SO)						CS Rising Edge												
	0	1	0	1	0	0	A0	R/W = 1	1	0	1	0	RB	RA	0	0	X	X	X	X		X	X	WCR9	WCR8	WCR7	WCR6	WCR5	WCR4	WCR3	WCR2	WCR1	WCR0
	0	1	0	1	0	0	A0	R/W = 1	1	0	1	0	RB	RA	0	0	X	X	X	X	X	X	WCR9	WCR8	WCR7	WCR6	WCR5	WCR4	WCR3	WCR2	WCR1	WCR0	

**Write Data Register (DR)**

$\overline{\text{CS}}$ Falling Edge	Device Type Identifier		Device Addresses		Instruction Opcode				Register Address				Wiper Position or Data (Sent by Master on SI)					Wiper Position or Data (Sent by Master on SI)					$\overline{\text{CS}}$ Rising Edge	HIGH-VOLTAGE WRITE CYCLE										
	0	1	0	1	0	0	A0	R/W = 0	1	1	0	0	RB	RA	0	0	X	X	X	X	X	X			WCR9	WCR8	WCR7	WCR6	WCR5	WCR4	WCR3	WCR2	WCR1	WCR0
	0	1	0	1	0	0	A0	R/W = 0	1	1	0	0	RB	RA	0	0	X	X	X	X	X	X	WCR9	WCR8	WCR7	WCR6	WCR5	WCR4	WCR3	WCR2	WCR1	WCR0		

**Transfer Data Register (DR) to Wiper Counter Register (WCR)**

$\overline{\text{CS}}$ Falling Edge	Device Type Identifier		Device Addresses		Instruction Opcode				Register Address				$\overline{\text{CS}}$ Rising Edge				
	0	1	0	1	0	0	A0	R/W = 1	1	1	0	0		RB	RA	0	0
	0	1	0	1	0	0	A0	R/W = 1	1	1	0	0	RB	RA	0	0	

**Transfer Wiper Counter Register (WCR) to Data Register (DR)**

$\overline{\text{CS}}$ Falling Edge	Device Type Identifier		Device Addresses		Instruction Opcode				Register Address				$\overline{\text{CS}}$ Rising Edge	HIGH-VOLTAGE WRITE CYCLE				
	0	1	0	1	0	0	A0	R/W = 0	1	1	1	0			RB	RA	0	0
	0	1	0	1	0	0	A0	R/W = 0	1	1	1	0	RB	RA	0	0		

**Read Status Register (SR)**

$\overline{\text{CS}}$ Falling Edge	Device Type Identifier		Device Addresses		Instruction Opcode				Register Addresses				Status Data (Sent by Slave on SO)					Status Data (Sent by Slave on SO)					$\overline{\text{CS}}$ Rising Edge												
	0	1	0	1	0	0	A0	R/W = 1	0	1	0	X	0	0	0	1	X	X	X	X	X	X		X	X	X	0	0	0	0	0	0	0	WIP	
	0	1	0	1	0	0	A0	R/W = 1	0	1	0	X	0	0	0	1	X	X	X	X	X	X	X	X	X	X	0	0	0	0	0	0	0	WIP	

NOTES:

1. "A0": stands for the device address sent by the master.
2. WCRx refers to wiper position data in the Wiper Counter Register
3. "X": Don't Care.

**Absolute Maximum Ratings**

Voltage on SCK any Address Input with Respect to V <sub>SS</sub> . . . . .	-1V to +7V
Voltage on V+ (referenced to V <sub>SS</sub> ) (Note 8) . . . . .	10V
Voltage on V- (referenced to V <sub>SS</sub> ) (Note 8) . . . . .	-10V
(V+) - (V-) . . . . .	12V
Any Voltage on R <sub>H</sub> /R <sub>L</sub> . . . . .	V+
Any Voltage on R <sub>L</sub> /R <sub>H</sub> . . . . .	V-
I <sub>W</sub> (10s) . . . . .	±6mA

**Thermal Information**

Thermal Resistance (Typical, Note 4)	θ <sub>JA</sub> (°C/W)
14 Lead TSSOP . . . . .	90
Temperature Under Bias . . . . .	-65°C to +135°C
Storage Temperature . . . . .	-65°C to +150°C
Pb-Free Reflow Profile . . . . .	see link below
<a href="http://www.intersil.com/pbfree/Pb-FreeReflow.asp">http://www.intersil.com/pbfree/Pb-FreeReflow.asp</a>	

**Recommended Operating Conditions**

Temperature Range	
Commercial . . . . .	0°C to +70°C
Industrial . . . . .	-40°C to +85°C
Supply Voltage (V <sub>CC</sub> ) Limits (Note 8)	
X9110 . . . . .	5V ± 10%
X9110-2.7 . . . . .	2.7V to 5.5V

CAUTION: Do not operate at or near the maximum ratings listed for extended periods of time. Exposure to such conditions may adversely impact product reliability and result in failures not covered by warranty.

NOTE:

- θ<sub>JA</sub> is measured with the component mounted on a high effective thermal conductivity test board in free air. See Tech Brief TB379 for details.

**Analog Specifications** *Over recommended industrial (2.7V) operation conditions unless otherwise stated.*

SYMBOL	PARAMETER	TEST CONDITIONS	MIN (Note 13)	TYP	MAX (Note 13)	UNITS
R <sub>TOTAL</sub>	End to End Resistance			100		kΩ
	End to End Resistance Tolerance				±20	%
	Power Rating	+25°C, each potentiometer			50	mW
I <sub>W</sub>	Wiper Current				±3	mA
R <sub>W</sub>	Wiper Resistance	Wiper Current = ±3mA, V <sub>CC</sub> = 3V		150	500	Ω
R <sub>W</sub>	Wiper Resistance	I <sub>W</sub> = ±3mA, V <sub>CC</sub> = 5V			100	Ω
V <sub>v+</sub>	Voltage on V+ Pin	X9110 (Note 8)	+4.5		+5.5	V
		X9110-2.7 (Note 8)	+2.7		+5.5	V
V <sub>v-</sub>	Voltage on V- Pin	X9110 (Note 8)	-5.5		-4.5	V
		X9110-2.7 (Note 8)	-5.5		-2.7	V
V <sub>TERM</sub>	Voltage on any R <sub>H</sub> or R <sub>L</sub> Pin	V <sub>SS</sub> = 0V	V-		V+	V
	Noise	Ref: 1V		-120		dBV
	Resolution			0.1		%
	Absolute Linearity (Note 5)	R <sub>w(n)(actual)</sub> - R <sub>w(n)(expected)</sub> , where n = 8 to 1006			±1	MI (Note 7)
		R <sub>w(n)(actual)</sub> - R <sub>w(n)(expected)</sub> (Note 9)			±1.5	MI (Note 7)
	Relative Linearity (Note 6)	R <sub>w(m+1)</sub> - [R <sub>w(m)</sub> + MI], where m = 8 to 1006			±0.5	MI (Note 7)
		R <sub>w(m+1)</sub> - [R <sub>w(m)</sub> + MI] (Note 9)			±1	MI (Note 7)
	Temperature Coefficient of R <sub>TOTAL</sub>			±300		ppm/°C
	Ratiometric Temp. Coefficient				20	ppm/°C
C <sub>H</sub> /C <sub>L</sub> /C <sub>W</sub>	Potentiometer Capacitancies	See macro model		10/10/25		pF

NOTES:

- Absolute linearity is utilized to determine actual wiper voltage versus expected voltage as determined by wiper position when used as a potentiometer.
- Relative linearity is utilized to determine the actual change in voltage between two successive tap positions when used as a potentiometer. It is a measure of the error in step size.
- MI = RTOT/1023 or (R<sub>H</sub> - R<sub>L</sub>)/1023, single pot
- V<sub>CC</sub>, V+, V- must reach their final values within 1ms of each other.
- n = 0, 1, 2, ..., 1023; m = 0, 1, 2, ..., 1022.

**D.C. Operating Specifications** *Over the recommended operating conditions unless otherwise specified.*

SYMBOL	PARAMETER	TEST CONDITIONS	MIN (Note 13)	TYP	MAX (Note 13)	UNITS
I <sub>CC1</sub>	V <sub>CC</sub> Supply Current (active)	f <sub>SCK</sub> = 2.5 MHz, SO = Open, V <sub>CC</sub> = 5.5V Other Inputs = V <sub>SS</sub>			400	μA
I <sub>CC2</sub>	V <sub>CC</sub> Supply Current (nonvolatile write)	f <sub>SCK</sub> = 2.5MHz, SO = Open, V <sub>CC</sub> = 5.5V Other Inputs = V <sub>SS</sub>		1	5	mA
I <sub>SB</sub>	V <sub>CC</sub> Current (standby)	SCK = SI = V <sub>SS</sub> , Addr. = V <sub>SS</sub> , CS = V <sub>CC</sub> = 5.5V			3	μA
I <sub>LI</sub>	Input Leakage Current	V <sub>IN</sub> = V <sub>SS</sub> to V <sub>CC</sub>			10	μA
I <sub>LO</sub>	Output Leakage Current	V <sub>OUT</sub> = V <sub>SS</sub> to V <sub>CC</sub>			10	μA
V <sub>IH</sub>	Input HIGH Voltage		V <sub>CC</sub> x 0.7		V <sub>CC</sub> + 1	V
V <sub>IL</sub>	Input LOW Voltage		-1		V <sub>CC</sub> x 0.3	V
V <sub>OL</sub>	Output LOW Voltage	I <sub>OL</sub> = 3mA			0.4	V
V <sub>OH</sub>	Output HIGH Voltage	I <sub>OH</sub> = -1mA, V <sub>CC</sub> ≥ +3V	V <sub>CC</sub> - 0.8			V
V <sub>OH</sub>	Output HIGH Voltage	I <sub>OH</sub> = -0.4mA, V <sub>CC</sub> ≤ +3V	V <sub>CC</sub> - 0.4			V

**Endurance and Data Retention**

PARAMETER	MIN	UNITS
Minimum Endurance	100,000	Data changes per bit per register
Data Retention	100	years

**Capacitance**

SYMBOL	TEST	TEST CONDITIONS	MAX	UNITS
C <sub>IN/OUT</sub> (Notes 8, 10)	Input/Output Capacitance (SI)	V <sub>OUT</sub> = 0V	8	pF
C <sub>OUT</sub> (Note 10)	Output Capacitance (SO)	V <sub>OUT</sub> = 0V	8	pF
C <sub>IN</sub> (Note 10)	Input Capacitance (A0, CS, WP, HOLD, and SCK)	V <sub>IN</sub> = 0V	6	pF

**Power-up Timing**

SYMBOL	PARAMETER	MIN	MAX	UNITS
t <sub>r</sub> V <sub>CC</sub> (Note 10)	V <sub>CC</sub> Power-up Rate	0.2	50	V/ms
t <sub>PUR</sub> (Notes 10, 11)	Power-up to Initiation of Read Operation		1	ms
t <sub>PURW</sub> (Note 11)	Power-up to Initiation of Write Operation		50	ms

NOTES:

10. Limits established by characterization and are not production tested.
11. t<sub>PUR</sub> and t<sub>PURW</sub> are the delays required from the time the (last) power supply (V<sub>CC</sub>-) is stable until the specific instruction can be issued.
12. ESD Rating on R<sub>H</sub>, R<sub>L</sub>, R<sub>W</sub> pins is 1.5kV (HBM, 1.0μA leakage maximum), ESD rating on all other pins is 2.0kV.
13. Parts are 100% tested at +25°C. Over-temperature limits established by characterization and are not production tested.

**A.C. Test Conditions**

Input Pulse Levels	V <sub>CC</sub> x 0.1 to V <sub>CC</sub> x 0.9
Input Rise and Fall Times	10ns
Input and Output Timing Level	V <sub>CC</sub> x 0.5

Equivalent A.C. Load Circuit

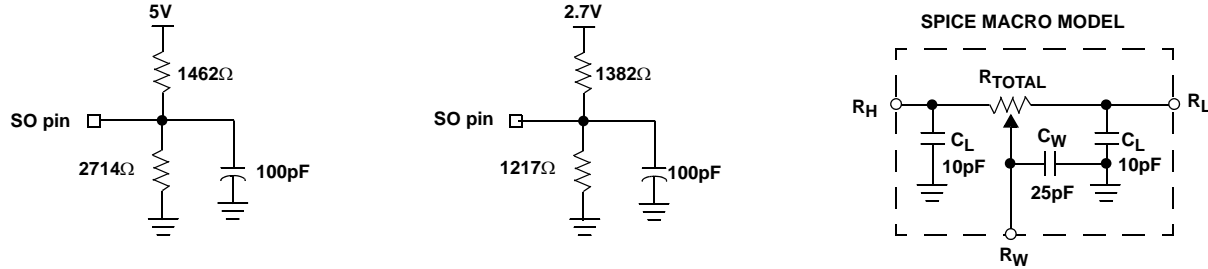

AC Timing

SYMBOL	PARAMETER	MIN	MAX	UNITS
f <sub>SCK</sub>	SSI/SPI Clock Frequency		2.0	MHz
t <sub>CYC</sub>	SSI/SPI Clock Cycle Time	400		ns
t <sub>WH</sub>	SSI/SPI Clock High Time	150		ns
t <sub>WL</sub>	SSI/SPI Clock Low Time	150		ns
t <sub>LEAD</sub>	Lead Time	150		ns
t <sub>LAG</sub>	Lag Time	150		ns
t <sub>SU</sub>	SI, SCK, $\overline{\text{HOLD}}$ and $\overline{\text{CS}}$ Input Setup Time	50		ns
t <sub>H</sub>	SI, SCK, $\overline{\text{HOLD}}$ and $\overline{\text{CS}}$ Input Hold Time	50		ns
t <sub>RI</sub>	SI, SCK, $\overline{\text{HOLD}}$ and $\overline{\text{CS}}$ Input Rise Time		50	ns
t <sub>FI</sub>	SI, SCK, $\overline{\text{HOLD}}$ and $\overline{\text{CS}}$ Input Fall Time		50	ns
t <sub>DIS</sub>	SO Output Disable Time	0	500	ns
t <sub>V</sub>	SO Output Valid Time		100	ns
t <sub>HO</sub>	SO Output Hold Time	0		ns
t <sub>RO</sub>	SO Output Rise Time		50	ns
t <sub>FO</sub>	SO Output Fall Time		50	ns
t <sub>HOLD</sub>	$\overline{\text{HOLD}}$ Time	400		ns
t <sub>HSU</sub>	$\overline{\text{HOLD}}$ Setup Time	50		ns
t <sub>HH</sub>	$\overline{\text{HOLD}}$ Hold Time	50		ns
t <sub>HZ</sub>	$\overline{\text{HOLD}}$ Low to Output in High Z		100	ns
t <sub>LZ</sub>	$\overline{\text{HOLD}}$ High to Output in Low Z		100	ns
T <sub>I</sub>	Noise Suppression Time Constant at SI, SCK, $\overline{\text{HOLD}}$ and $\overline{\text{CS}}$ Inputs		20	ns
t <sub>CS</sub>	$\overline{\text{CS}}$ Deselect Time	100		ns
t <sub>WPASU</sub>	$\overline{\text{WP}}$ , A0 Setup Time	0		ns
t <sub>WPAH</sub>	$\overline{\text{WP}}$ , A0 Hold Time	0		ns





**High-Voltage Write Cycle Timing**

SYMBOL	PARAMETER	TYP	MAX	UNITS
$t_{WR}$	High-Voltage Write Cycle Time (store instructions)	5	10	ms

**XDCP Timing**

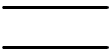
SYMBOL	PARAMETER	MIN	MAX	UNITS
$t_{WRPO}$	Wiper Response Time After the Third (last) Power Supply is Stable	5	10	$\mu$ s
$t_{WRL}$	Wiper Response Time After Instruction Issued (all load instructions)	5	10	$\mu$ s

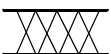
**Symbol Table**

WAVEFORM	INPUTS	OUTPUTS
	Must be steady	Will be steady
	May change from Low to High	Will change from Low to High
	May change from High to Low	Will change from High to Low
	Don't Care: Changes Allowed	Changing: State Not Known
	N/A	Center Line is High Impedance

## Timing Diagrams

### Input Timing

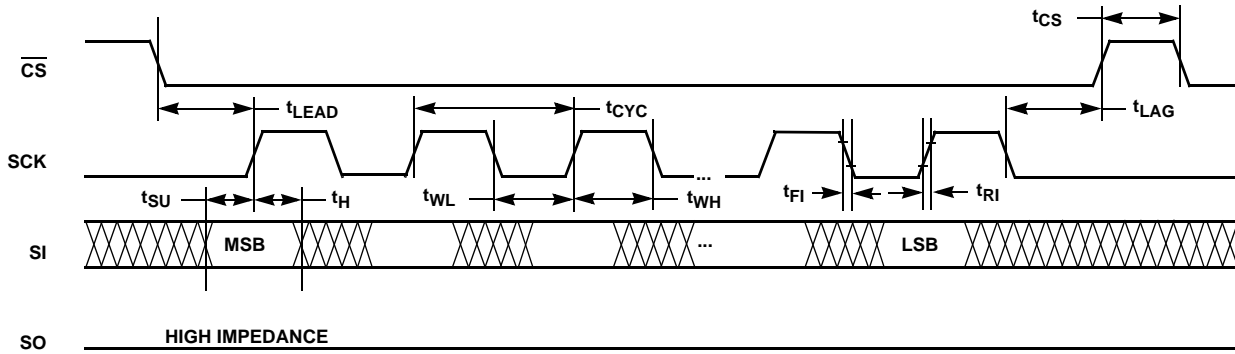

### Output Timing

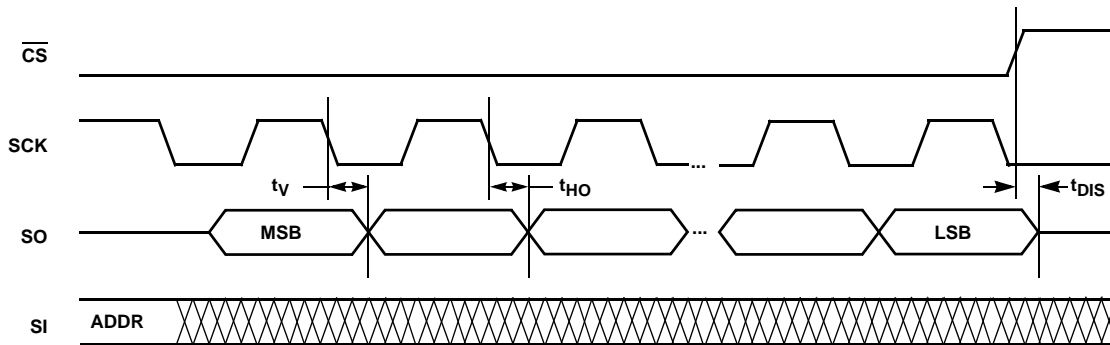

### Hold Timing

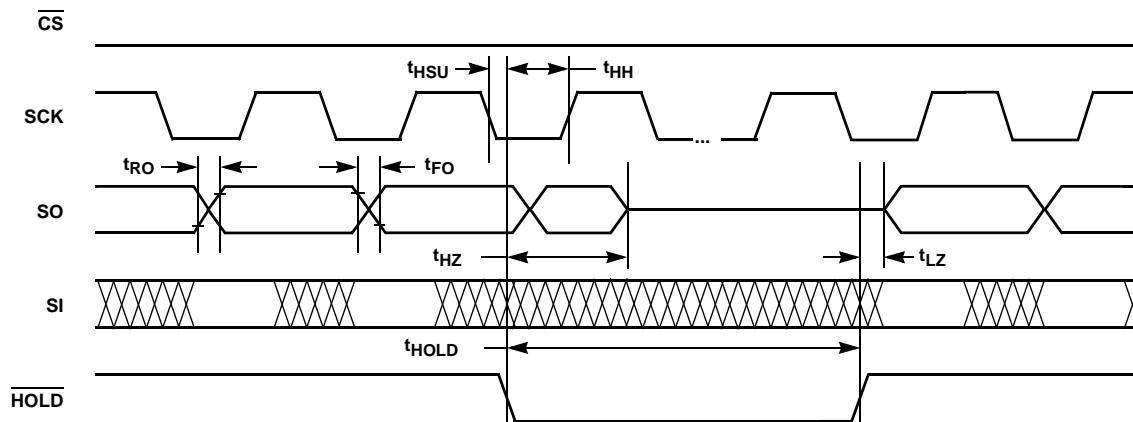

**XDCP Timing (For All Load Instructions)**

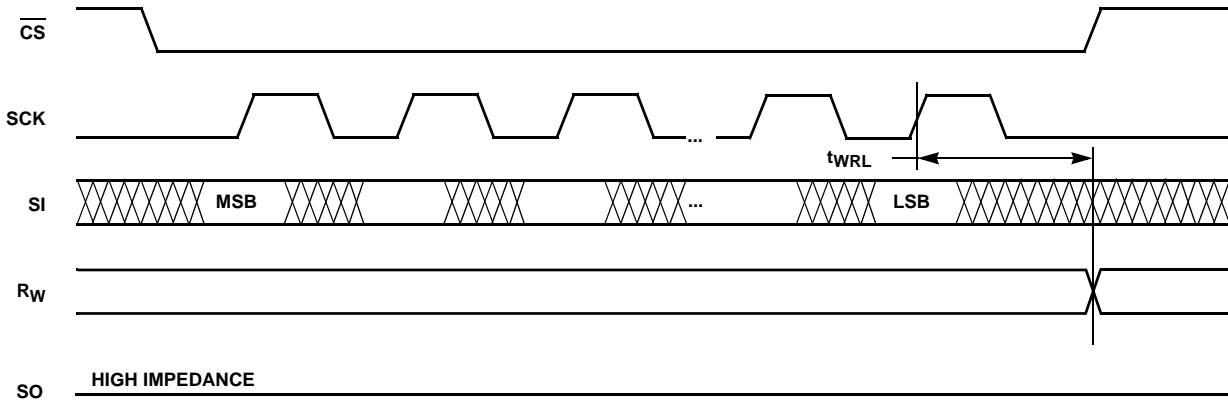

**Write Protect And Device Address Pins Timing**

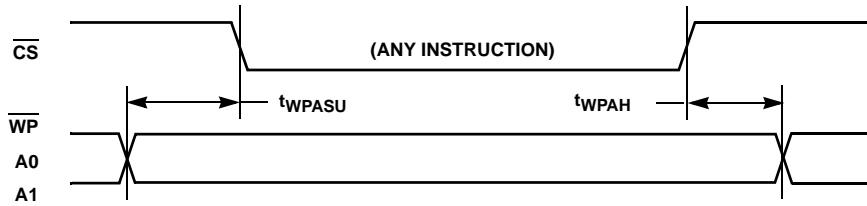

**Applications information**

**Basic Configurations Of Electronic Potentiometers**

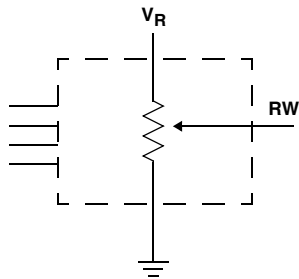

Three terminal Potentiometer;  
Variable voltage divider

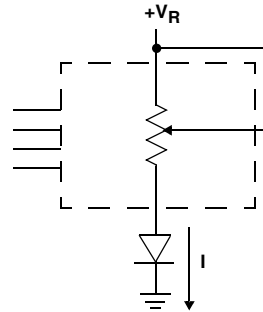

Two terminal Variable Resistor;  
Variable current

Application Circuits

NONINVERTING AMPLIFIER

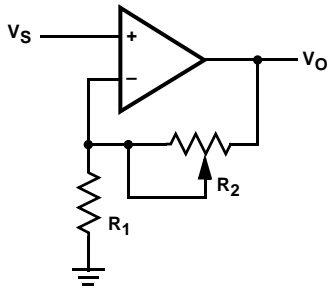

$$V_O = (1 + R_2/R_1)V_S$$

VOLTAGE REGULATOR

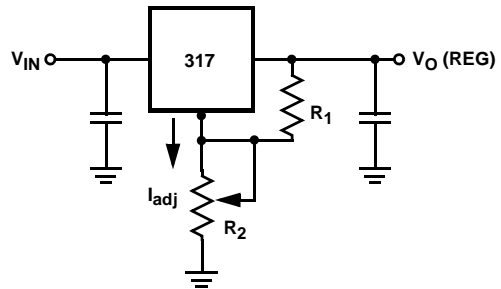

$$V_O (\text{REG}) = 1.25V (1 + R_2/R_1) + I_{\text{adj}} R_2$$

OFFSET VOLTAGE ADJUSTMENT

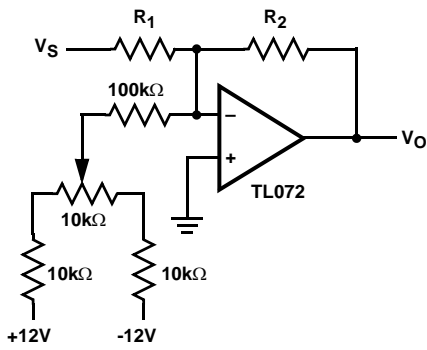

COMPARATOR WITH HYSTERESIS

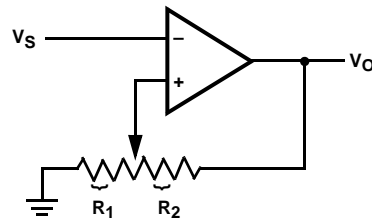

$$V_{UL} = \{R_1/(R_1+R_2)\} V_O(\text{max})$$

$$V_{LL} = \{R_1/(R_1+R_2)\} V_O(\text{min})$$

Application Circuits (continued)

ATTENUATOR

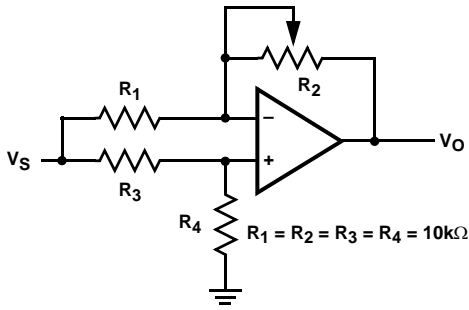

$$V_O = G V_S$$

$$-1/2 \leq G \leq +1/2$$

FILTER

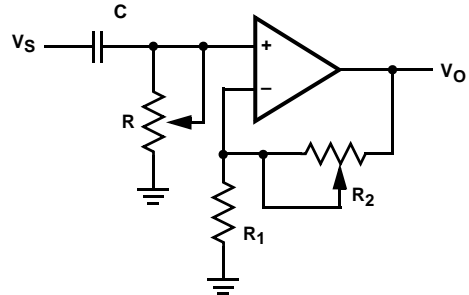

$$G_O = 1 + R_2/R_1$$

$$f_c = 1/(2\pi RC)$$

INVERTING AMPLIFIER

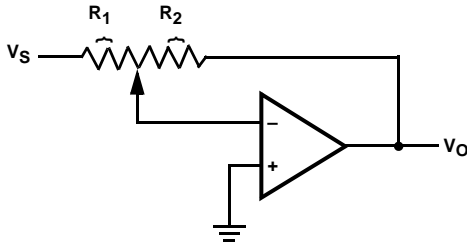

$$V_O = G V_S$$

$$G = -R_2/R_1$$

EQUIVALENT L-R CIRCUIT

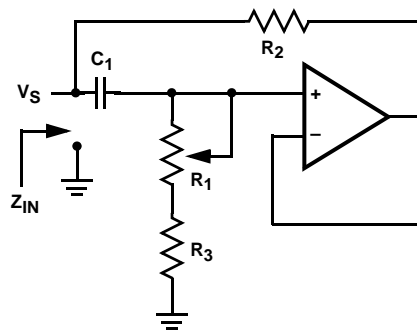

$$Z_{IN} = R_2 + s R_2 (R_1 + R_3) \quad C_1 = R_2 + s L_{eq}$$

$$(R_1 + R_3) \gg R_2$$

FUNCTION GENERATOR

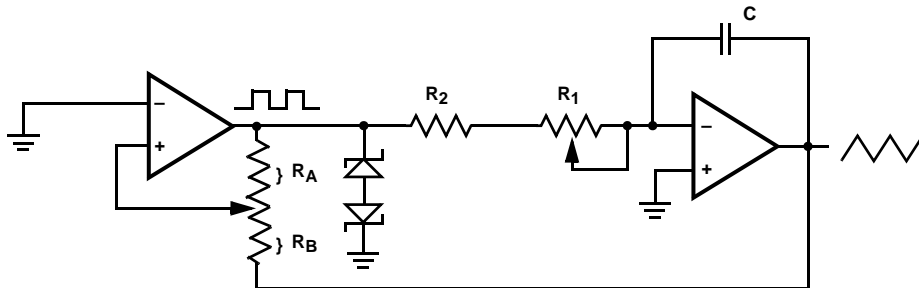

frequency  $\propto R_1, R_2, C$   
 amplitude  $\propto R_A, R_B$

**Thin Shrink Small Outline Plastic Packages (TSSOP)**

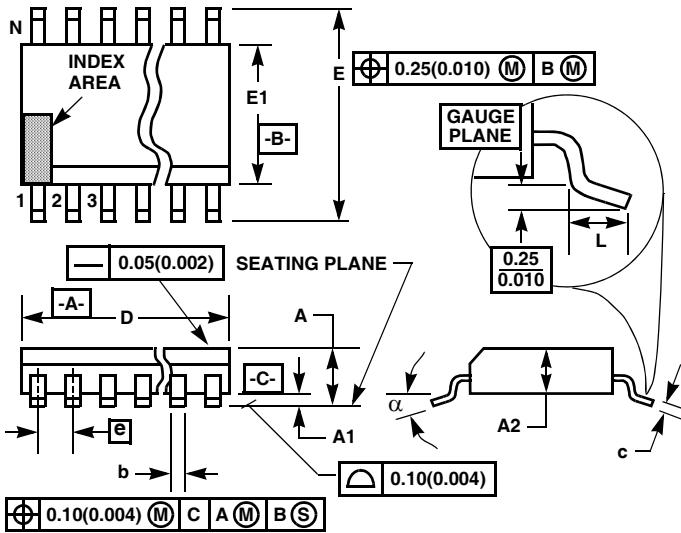

**M14.173**  
**14 LEAD THIN SHRINK SMALL OUTLINE PLASTIC PACKAGE**

SYMBOL	INCHES		MILLIMETERS		NOTES
	MIN	MAX	MIN	MAX	
A	-	0.047	-	1.20	-
A1	0.002	0.006	0.05	0.15	-
A2	0.031	0.041	0.80	1.05	-
b	0.0075	0.0118	0.19	0.30	9
c	0.0035	0.0079	0.09	0.20	-
D	0.195	0.199	4.95	5.05	3
E1	0.169	0.177	4.30	4.50	4
e	0.026 BSC		0.65 BSC		-
E	0.246	0.256	6.25	6.50	-
L	0.0177	0.0295	0.45	0.75	6
N	14		14		7
$\alpha$	0°	8°	0°	8°	-

Rev. 2 4/06

**NOTES:**

- These package dimensions are within allowable dimensions of JEDEC MO-153-AC, Issue E.
- Dimensioning and tolerancing per ANSI Y14.5M-1982.
- Dimension "D" does not include mold flash, protrusions or gate burrs. Mold flash, protrusion and gate burrs shall not exceed 0.15mm (0.006 inch) per side.
- Dimension "E1" does not include interlead flash or protrusions. Interlead flash and protrusions shall not exceed 0.15mm (0.006 inch) per side.
- The chamfer on the body is optional. If it is not present, a visual index feature must be located within the crosshatched area.
- "L" is the length of terminal for soldering to a substrate.
- "N" is the number of terminal positions.
- Terminal numbers are shown for reference only.
- Dimension "b" does not include dambar protrusion. Allowable dambar protrusion shall be 0.08mm (0.003 inch) total in excess of "b" dimension at maximum material condition. Minimum space between protrusion and adjacent lead is 0.07mm (0.0027 inch).
- Controlling dimension: MILLIMETER. Converted inch dimensions are not necessarily exact. (Angles in degrees)

All Intersil U.S. products are manufactured, assembled and tested utilizing ISO9000 quality systems. Intersil Corporation's quality certifications can be viewed at [www.intersil.com/design/quality](http://www.intersil.com/design/quality)

*Intersil products are sold by description only. Intersil Corporation reserves the right to make changes in circuit design, software and/or specifications at any time without notice. Accordingly, the reader is cautioned to verify that data sheets are current before placing orders. Information furnished by Intersil is believed to be accurate and reliable. However, no responsibility is assumed by Intersil or its subsidiaries for its use; nor for any infringements of patents or other rights of third parties which may result from its use. No license is granted by implication or otherwise under any patent or patent rights of Intersil or its subsidiaries.*

For information regarding Intersil Corporation and its products, see [www.intersil.com](http://www.intersil.com)