

TOSHIBA MOS DIGITAL INTEGRATED CIRCUIT SILICON GATE CMOS

**2 GBIT (256M × 8 BIT) CMOS NAND E<sup>2</sup>PROM****DESCRIPTION**

The TC58NVG1S3E is a single 3.3V 2 Gbit (2,214,592,512 bits) NAND Electrically Erasable and Programmable Read-Only Memory (NAND E<sup>2</sup>PROM) organized as (2048 + 64) bytes × 64 pages × 2048 blocks.

The device has two 2112-byte static registers which allow program and read data to be transferred between the register and the memory cell array in 2112-byte increments. The Erase operation is implemented in a single block unit (128 Kbytes + 4 Kbytes: 2112 bytes × 64 pages).

The TC58NVG1S3E is a serial-type memory device which utilizes the I/O pins for both address and data input/output as well as for command inputs. The Erase and Program operations are automatically executed making the device most suitable for applications such as solid-state file storage, voice recording, image file memory for still cameras and other systems which require high-density non-volatile memory data storage.

**FEATURES**

- Organization

|                   |                   |
|-------------------|-------------------|
|                   | x8                |
| Memory cell array | 2112 × 128K × 8   |
| Register          | 2112 × 8          |
| Page size         | 2112 bytes        |
| Block size        | (128K + 4K) bytes |
  
- Modes
  - Read, Reset, Auto Page Program, Auto Block Erase, Status Read, Page Copy, Multi Page Program, Multi Block Erase, Multi Page Copy, Multi Page Read
  
- Mode control
  - Serial input/output
  - Command control
  
- Number of valid blocks
  - Min 2008 blocks
  - Max 2048 blocks
  
- Power supply
  - V<sub>CC</sub> = 2.7V to 3.6V
  
- Access time

|                        |                      |
|------------------------|----------------------|
| Cell array to register | 25 μs max            |
| Serial Read Cycle      | 25 ns min (CL=100pF) |
  
- Program/Erase time

|                   |                   |
|-------------------|-------------------|
| Auto Page Program | 300 μs/page typ.  |
| Auto Block Erase  | 2.5 ms/block typ. |
  
- Operating current

|                    |            |
|--------------------|------------|
| Read (25 ns cycle) | 30 mA max. |
| Program (avg.)     | 30 mA max  |
| Erase (avg.)       | 30 mA max  |
| Standby            | 50 μA max  |
  
- Package
  - P-TFBGA63-1013-0.80AZ (Weight: 0.18 g typ.)

## PIN ASSIGNMENT (TOP VIEW)

|   |    |    |                 |                 |                 |                 |                 |                     |    |    |
|---|----|----|-----------------|-----------------|-----------------|-----------------|-----------------|---------------------|----|----|
|   | 1  | 2  | 3               | 4               | 5               | 6               | 7               | 8                   | 9  | 10 |
| A | NC | NC |                 |                 |                 |                 |                 |                     | NC | NC |
| B | NC |    |                 |                 |                 |                 |                 |                     | NC | NC |
| C |    |    | $\overline{WP}$ | ALE             | V <sub>SS</sub> | $\overline{CE}$ | $\overline{WE}$ | RY/ $\overline{BY}$ |    |    |
| D |    |    | NC              | $\overline{RE}$ | CLE             | NC              | NC              | NC                  |    |    |
| E |    |    | NC              | NC              | NC              | NC              | NC              | NC                  |    |    |
| F |    |    | NC              | NC              | NC              | NC              | NC              | NC                  |    |    |
| G |    |    | NC              | NC              | NC              | NC              | NC              | NC                  |    |    |
| H |    |    | NC              | I/O1            | NC              | NC              | NC              | V <sub>CC</sub>     |    |    |
| J |    |    | NC              | I/O2            | NC              | V <sub>CC</sub> | I/O6            | I/O8                |    |    |
| K |    |    | V <sub>SS</sub> | I/O3            | I/O4            | I/O5            | I/O7            | V <sub>SS</sub>     |    |    |
| L | NC | NC |                 |                 |                 |                 |                 |                     | NC | NC |
| M | NC | NC |                 |                 |                 |                 |                 |                     | NC | NC |

## PIN NAMES

|                     |                      |
|---------------------|----------------------|
| I/O1 to I/O8        | I/O port             |
| $\overline{CE}$     | Chip enable          |
| $\overline{WE}$     | Write enable         |
| $\overline{RE}$     | Read enable          |
| CLE                 | Command latch enable |
| ALE                 | Address latch enable |
| $\overline{WP}$     | Write protect        |
| RY/ $\overline{BY}$ | Ready/Busy           |
| V <sub>CC</sub>     | Power supply         |
| V <sub>SS</sub>     | Ground               |

## BLOCK DIAGRAM

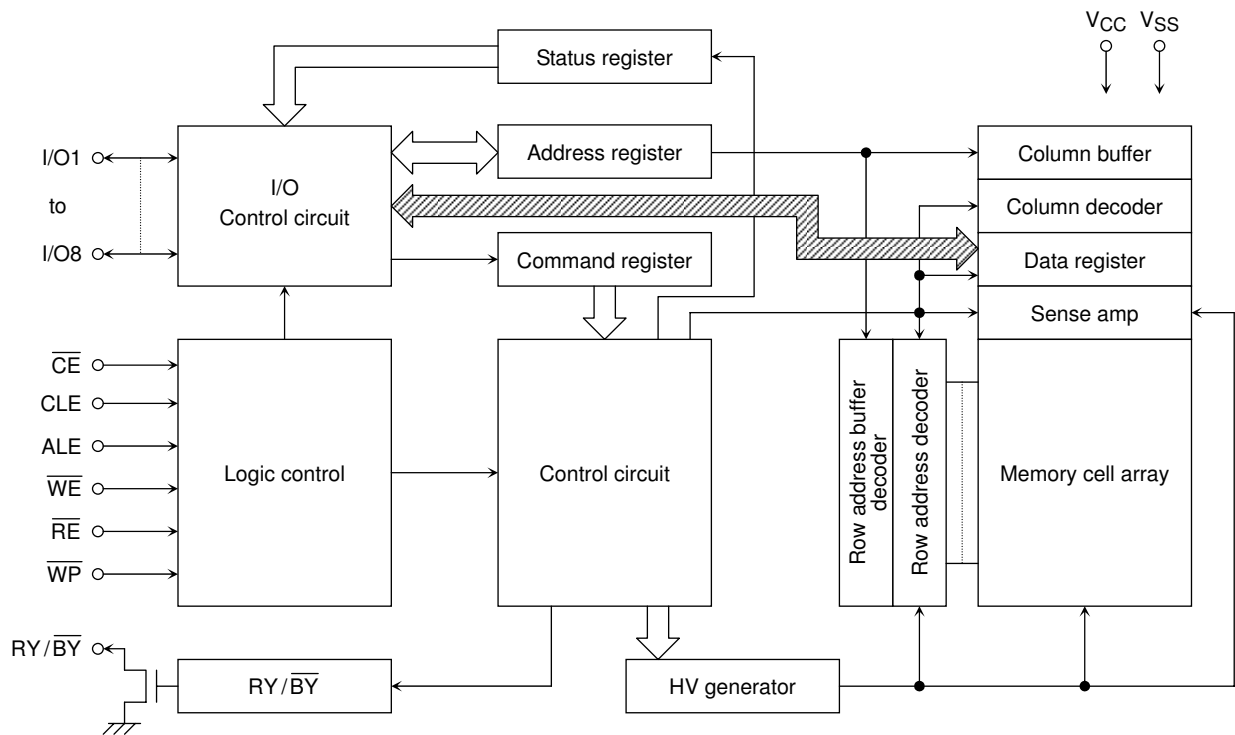

## ABSOLUTE MAXIMUM RATINGS

| SYMBOL              | RATING                       | VALUE                                   | UNIT |
|---------------------|------------------------------|---|------|
| V <sub>CC</sub>     | Power Supply Voltage         | -0.6 to 4.6                             | V    |
| V <sub>IN</sub>     | Input Voltage                | -0.6 to 4.6                             | V    |
| V <sub>I/O</sub>    | Input /Output Voltage        | -0.6 to V <sub>CC</sub> + 0.3 (≤ 4.6 V) | V    |
| P <sub>D</sub>      | Power Dissipation            | 0.3                                     | W    |
| T <sub>SOLDER</sub> | Soldering Temperature (10 s) | 260                                     | °C   |
| T <sub>STG</sub>    | Storage Temperature          | -55 to 125                              | °C   |
| T <sub>OPR</sub>    | Operating Temperature        | -40 to 85                               | °C   |

## CAPACITANCE \*(Ta = 25°C, f = 1 MHz)

| SYMBOL           | PARAMETER | CONDITION              | MIN | MAX | UNIT |
|------------------|-----------|------------------------|-----|-----|------|
| C <sub>IN</sub>  | Input     | V <sub>IN</sub> = 0 V  | —   | 10  | pF   |
| C <sub>OUT</sub> | Output    | V <sub>OUT</sub> = 0 V | —   | 10  | pF   |

\* This parameter is periodically sampled and is not tested for every device.