

## General Description

The AAT3158 is a low noise, constant frequency charge pump DC/DC converter that uses a tri-mode load switch (1X), fractional (1.5X), and doubling (2X) conversion to maximize efficiency for white LED applications. The AAT3158 is capable of driving up to four LED channels at 20mA per channel from a 2.7V to 5.5V input. The current sinks may be operated individually or in parallel for driving higher current LEDs. A low external parts count (two 1μF flying capacitors and two small 1μF capacitors at  $V_{IN}$  and  $V_{OUT}$ ) make this part ideally suited for small, battery-powered applications.

AnalogicTech's S<sup>2</sup>Cwire™ (Simple Serial Control™) serial digital input is used to enable, disable, and set current for each LED with 16 settings down to 50μA. The low current mode supply current can be as low as 50μA to save power.

Each output of the AAT3158 is equipped with built-in protection for  $V_{OUT}$  short circuit and auto disable for load short-circuit conditions. Built-in soft-start circuitry prevents excessive inrush current during start-up. A low current shutdown feature disconnects the load from  $V_{IN}$  and reduces quiescent current to less than 1μA.

The AAT3158 is available in a Pb-free, space-saving 2.85x3.0mm TSOPJW-12 package.

## Features

- $V_{IN}$  Range: 2.7V to 5.5V
- Fully Programmable Current with Single Wire
  - 16 Current Levels
  - Four Low Current Settings Down to 50μA
- Low  $I_Q$  (50μA) for Low Current Mode
- Tri-Mode 1X, 1.5X, and 2X Charge Pump for Maximum Efficiency and  $V_F$  Coverage
- Drives Up to Four LED Channels
- No Inductors, Low Noise Operation
- 1MHz Constant Switching Frequency
- Small Application Circuit
- Built-In Thermal Protection
- Automatic Soft-Start
- $I_Q < 1\mu A$  in Shutdown
- 2.85x3mm TSOPJW-12 Package

## Applications

- Color (RGB) Lighting
- Programmable Current Sinks
- White LED Backlighting
- White Photo Flash for Digital Still Cameras

## Typical Application

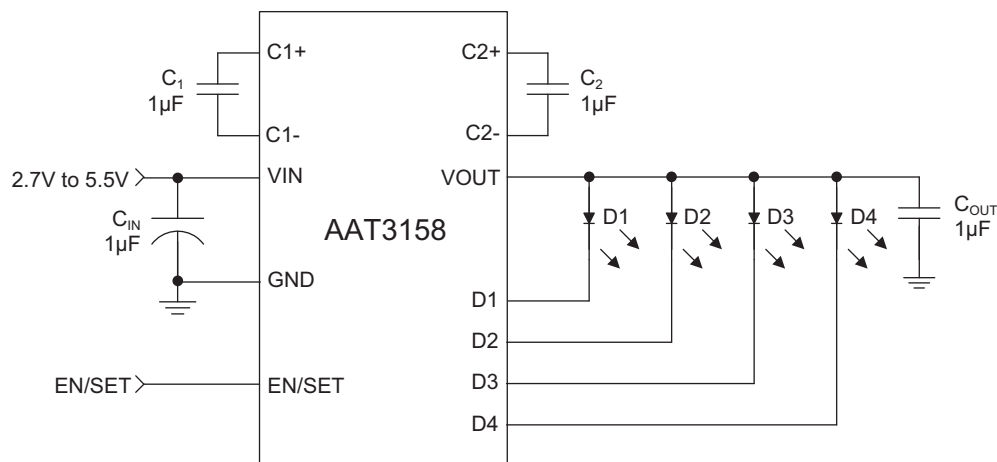

## Pin Descriptions

Pin #	Symbol	Function
1	D4	Current sink input #4.
2	EN/SET	S <sup>2</sup> Cwire serial interface control pin.
3	C1+	Flying capacitor 1 positive terminal. Connect a 1μF capacitor between C1+ and C1-.
4	C1-	Flying capacitor 1 negative terminal.
5	VOUT	Charge pump output to drive load circuit. Requires 1μF capacitor connected between this pin and ground.
6	C2+	Flying capacitor 2 positive terminal. Connect a 1μF capacitor between C2+ and C2-.
7	C2-	Flying capacitor 2 negative terminal.
8	VIN	Input power supply. Requires 1μF capacitor connected between this pin and ground.
9	GND	Ground.
10	D3	Current sink input #3.
11	D2	Current sink input #2.
12	D1	Current sink input #1.

## Pin Configuration

**TSOPJW-12  
(Top View)**

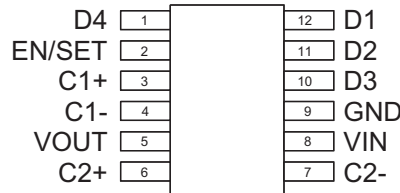

### Absolute Maximum Ratings<sup>1</sup>

Symbol	Description	Value	Units
$V_{IN}$	Input Voltage	-0.3 to 6	V
$V_{EN/SET}$	EN/SET to GND Voltage	-0.3 to $V_{IN} + 0.3$	V
$I_{OUT}^2$	Maximum DC Output Current	150	mA
$T_J$	Operating Junction Temperature Range	-40 to 150	°C
$T_{LEAD}$	Maximum Soldering Temperature (at leads, 10 sec.)	300	°C

### Thermal Information<sup>3</sup>

Symbol	Description	Value	Units
$P_D$	Maximum Power Dissipation <sup>4</sup>	0.625	W
$\theta_{JA}$	Maximum Thermal Resistance	160	°C/W

1. Stresses above those listed in Absolute Maximum Ratings may cause permanent damage to the device. Functional operation at conditions other than the operating conditions specified is not implied. Only one Absolute Maximum Rating should be applied at any one time.

2. Based on long-term current density limitation.

3. Mounted on an FR4 board.

4. Derate 6.25mW/°C above 25°C.

**ChargePump™ High Efficiency 1X/1.5X/2X Charge Pump for White LED Applications**
**Electrical Characteristics<sup>1</sup>**
 $C_{IN} = C_{OUT} = C_1 = C_2 = 1.0\mu\text{F}$ ;  $T_A = -40^\circ\text{C}$  to  $+85^\circ\text{C}$ , unless otherwise noted. Typical values are  $T_A = 25^\circ\text{C}$ ,  $V_{IN} = 3.6\text{V}$ .

Symbol	Description	Conditions	Min	Typ	Max	Units
<b>Input Power Supply</b>						
$V_{IN}$	Operation Range		2.7		5.5	V
$I_{CC}$	Operating Current	1X Mode, $3.0 \leq V_{IN} \leq 5.5$ , Active, No Load Current		0.3	1	mA
		1.5X Mode, $3.0 \leq V_{IN} \leq 5.5$ , Active, No Load Current		1	3	
		2X Mode, $3.0 \leq V_{IN} \leq 5.5$ , Active, No Load Current			1	
		50 $\mu\text{A}$ Setting, 1X Mode		50		$\mu\text{A}$
$I_{SHDN}$	Shutdown Current	EN/SET = 0			1	$\mu\text{A}$
$I_{DX}$	$I_{SINK}$ Average Current Accuracy		18	20	22	mA
$I_{(D-Match)}$	Current Matching <sup>2</sup>	VF:D1:D4 = 3.6V		0.5	1	%
$V_{TH}$	1X to 1.5X or 1.5X to 2X Transition Threshold at Any $I_{SINK}$ Pin			150		mV
<b>Charge Pump Section</b>						
$T_{SS}$	Soft-Start Time			100		$\mu\text{s}$
$F_{CLK}$	Clock Frequency			1000		kHz
<b>EN/ SET</b>						
$V_{EN(L)}$	Enable Threshold Low	$V_{IN} = 2.7\text{V}$			0.4	V
$V_{EN(H)}$	Enable Threshold High	$V_{IN} = 5.5\text{V}$	1.4			V
$T_{EN/SET LO}$	EN/SET Low Time		0.3		75	$\mu\text{s}$
$T_{EN/SET HI MIN}$	Minimum EN/SET High Time			50		ns
$T_{EN/SET HI MAX}$	Maximum EN/SET High Time				75	$\mu\text{s}$
$T_{OFF}$	EN/SET Off Timeout				500	$\mu\text{s}$
$T_{LAT}$	EN/SET Latch Timeout				500	$\mu\text{s}$
$I_{EN/SET}$	EN/SET Input Leakage		-1		1	$\mu\text{A}$

1. The AAT3158 is guaranteed to meet performance specifications over the  $-40^\circ\text{C}$  to  $+85^\circ\text{C}$  operating temperature range and is assured by design, characterization, and correlation with statistical process controls.

2. Current matching is defined as the deviation of any sink current from the average of all active channels.

Typical Characteristics

Efficiency vs. Supply Voltage

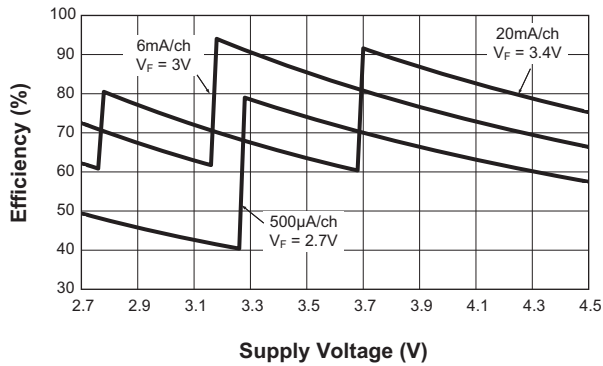

Turn-On to 1X Mode  
(VIN = 4.2V; 20mA/ch Load)

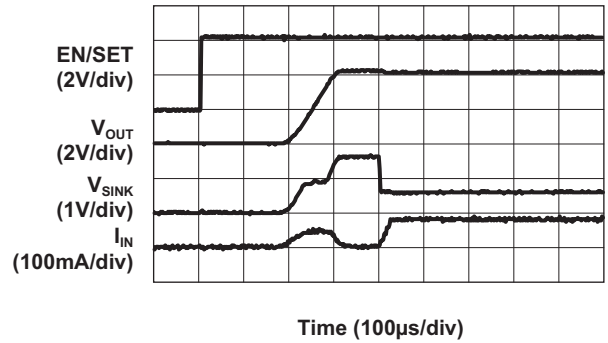

Turn-On to 1.5X Mode  
(VIN = 3.5V; 20mA/ch Load)

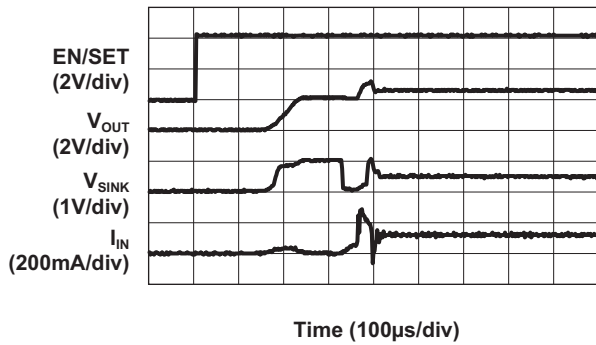

Turn-On to 2X Mode  
(VIN = 2.8V; 20mA/ch Load)

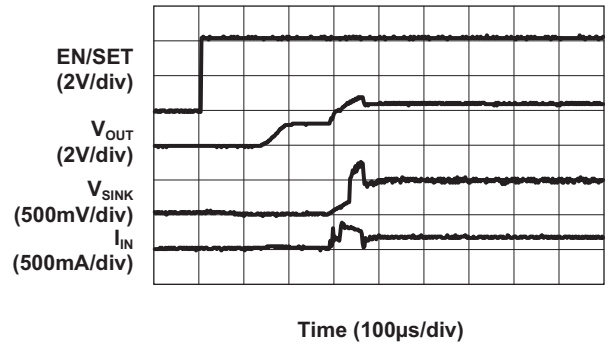

Turn-Off from 1.5X Mode  
(VIN = 3.5V; 20mA/ch Load)

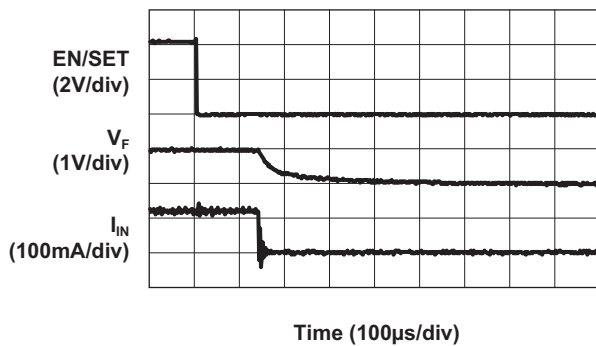

Diode Current vs. Temperature  
(20mA/channel)

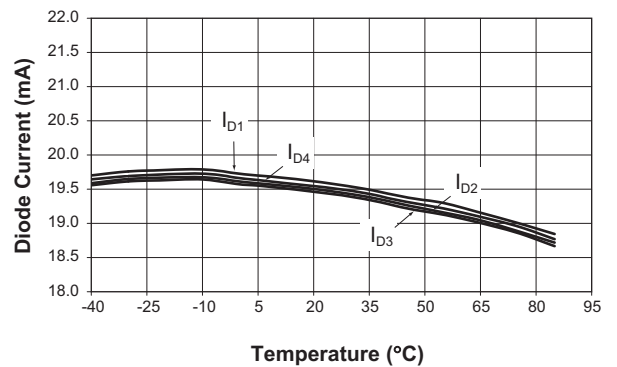

## Typical Characteristics

**Load Characteristics**  
( $V_{IN} = 3.7V$ ; 1.5X Mode; 20mA/ch Load)

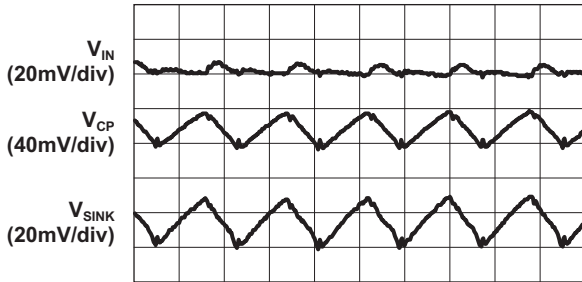

Time (500ns/div)

**Load Characteristics**  
( $V_{IN} = 3.5V$ ; 1.5X Mode; 14mA/ch Load)

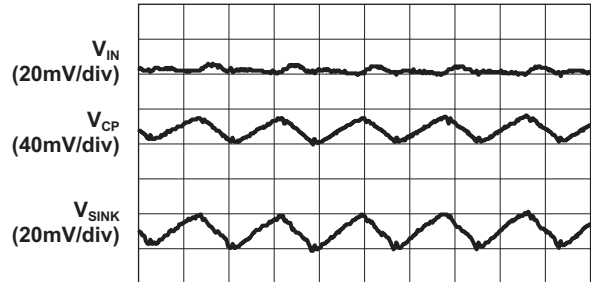

Time (500ns/div)

**Load Characteristics**  
( $V_{IN} = 2.9V$ ; 2X Mode; 20mA/ch Load)

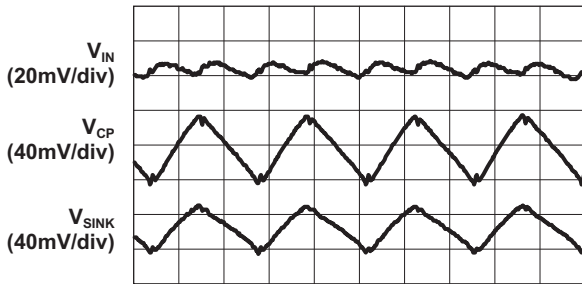

Time (500ns/div)

**Load Characteristics**  
( $V_{IN} = 2.9V$ ; 2X Mode; 14mA/ch Load)

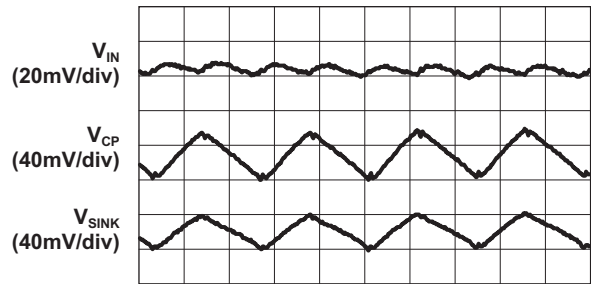

Time (500ns/div)

### Input Ripple vs. Input Voltage

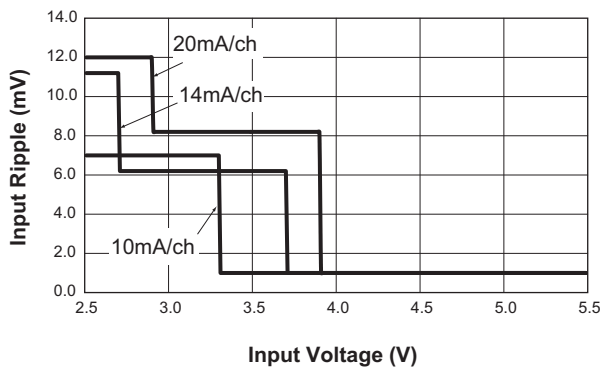

## Typical Characteristics

EN/SET Latch Timeout vs. Input Voltage

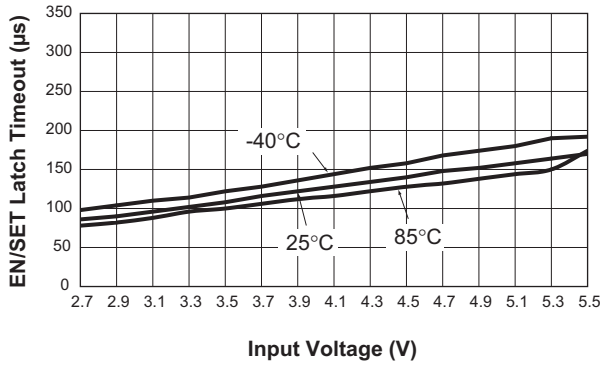

EN/SET Off Timeout vs. Input Voltage

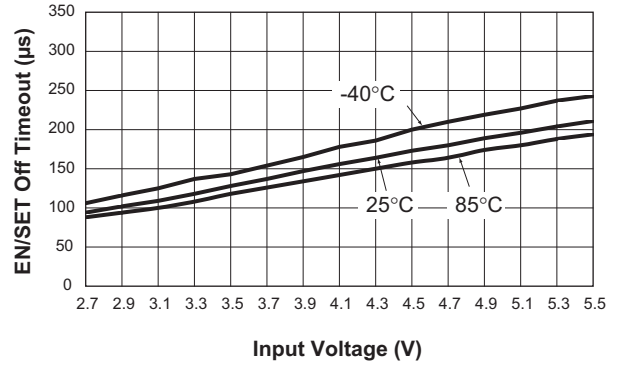

Enable Threshold High vs. Input Voltage

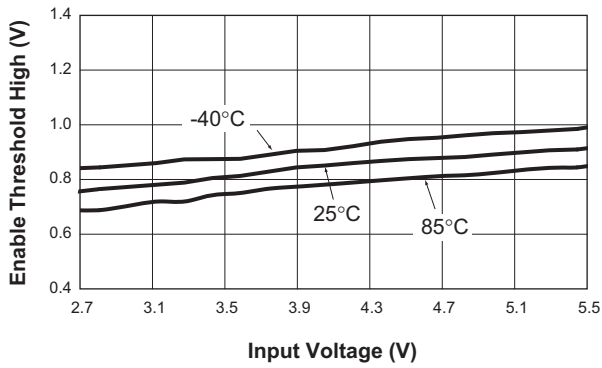

Enable Threshold Low vs. Input Voltage

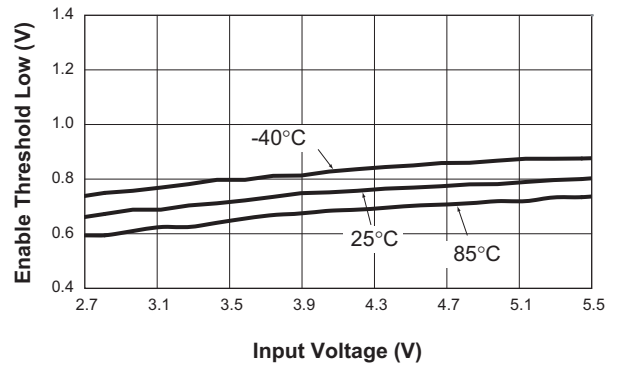

## Functional Block Diagram

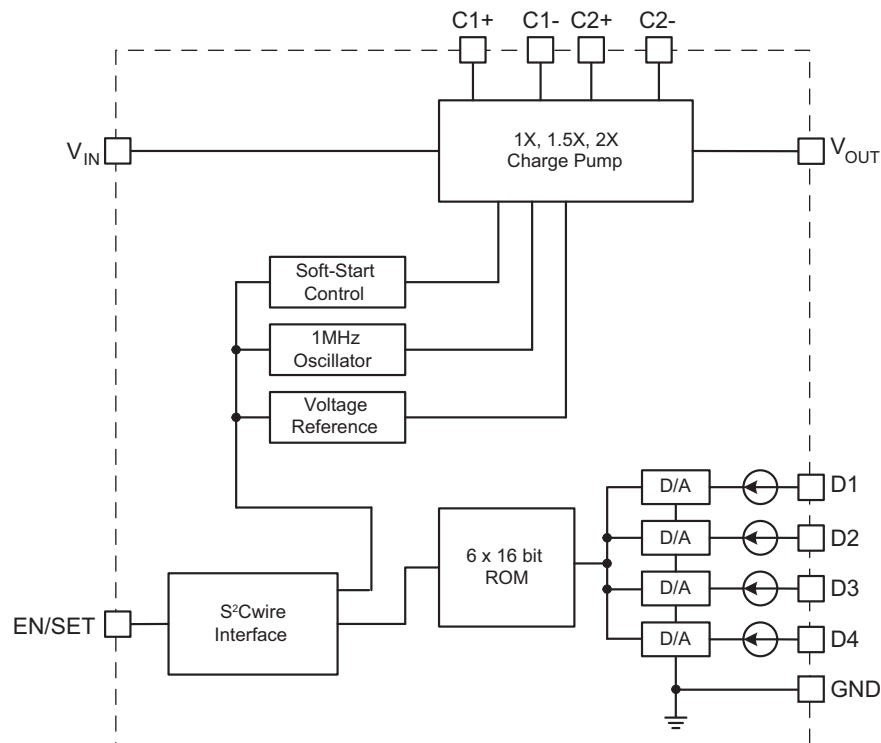

## Functional Description

The AAT3158 is a tri-mode load switch (1X) and high efficiency (1.5X or 2X) charge pump device intended for white LED backlight applications. To maximize power conversion efficiency, an internal sensing circuit monitors the voltage required on each constant current sink input and sets the load switch and charge pump modes based on the input battery voltage and the current sink input voltage. As the battery discharges over time, the AAT3158 charge pump is enabled when any of the four current sink inputs nears dropout. The charge pump initially starts in 1.5X mode. If the charge pump output droops enough for any current source output to become close to dropout, the charge pump will automatically transition to 2X mode. The AAT3158 requires only four external components: two  $1\mu\text{F}$  ceramic capacitors for the charge pump flying capacitors ( $C_1$  and  $C_2$ ), one  $1\mu\text{F}$  ceramic input capacitor ( $C_{IN}$ ), and one  $0.33\mu\text{F}$  to  $1\mu\text{F}$  ceramic charge pump output capacitor ( $C_{OUT}$ ).

The four constant current sink inputs (D1 to D4) can drive four individual LEDs with a maximum current of 20mA each. The unused sink inputs must be connected to  $V_{OUT}$ ; otherwise, the part will operate only in 2X charge pump mode. The S<sup>2</sup>Cwire serial interface enables the AAT3158 and sets the current sink magnitudes.

## Constant Current Output Level Settings

The constant current sink levels for D1 to D4 are set via the serial interface according to a logarithmic scale for the first 12 codes, and a separate low current scale for the last 4 codes. For the first 12 codes, each code is approximately 1.5dB lower than the previous code. In this manner, LED brightness appears linear with each increasing code count. Because the inputs D1 to D4 are true independent constant current sinks, the voltage observed on any single given input will be determined by the actual forward voltage ( $V_F$ ) for the LED being driven.

## ChargePump™ High Efficiency 1X/1.5X/2X Charge Pump for White LED Applications

Since the input current sinks of the AAT3158 are programmable, no PWM (pulse width modulation) or additional control circuitry is needed to control LED brightness. This feature greatly reduces the burden on a microcontroller or system IC to manage LED or display brightness, allowing the user to “set it and forget it.” With its high-speed serial interface (1MHz data rate), the input sink current of the AAT3158 can be changed successively to brighten or dim LEDs in smooth transitions (e.g., to fade-out) or in abrupt steps, giving the user complete programmability and real-time control of LED brightness.

### S<sup>2</sup>Cwire Serial Interface

The current level magnitude is controlled by AnalogicTech’s Simple Serial Control (S<sup>2</sup>Cwire) serial interface. The interface records rising edges of the EN/SET pin and decodes them into 16 different states. The 16 current level settings available are indicated in Table 1.

Data	Output (mA/ Ch)	Data	Output (mA/ Ch)
1	20	9	6
2	18	10	4
3	16	11	3
4	14	12	2
5	12.5	13	1
6	11	14	0.5
7	9.5	15	0.1
8	8	16	0.05

Table 1: Current Level Settings.

The S<sup>2</sup>Cwire serial interface has flexible timing. Data can be clocked-in at speeds greater than 1MHz, or much slower, such as 15kHz. After data is submitted, EN/SET is held high to latch the data. Once EN/SET has been held in the logic high state for time  $T_{LAT}$ , the programmed current becomes active and the internal data register is reset to zero. For subsequent current level programming, the number of rising edges corresponding to the desired code must be entered on the EN/SET pin.

When EN/SET is held low for an amount of time greater than  $T_{OFF}$ , the AAT3158 enters into shutdown mode and draws less than 1µA from  $V_{IN}$ . The internal data register is reset to zero during shutdown.

### Auto-Disable Feature

The AAT3158 is equipped with an auto-disable feature for each LED channel. After the IC is enabled and started up, a test current of 100µA (typical) is forced through each sink channel. The channel will be disabled if the voltage of that particular SINK pin does not drop to certain threshold. This feature is very convenient for disabling an unused channel or during an LED fail short event.

### Thermal Protection

The AAT3158 has built-in thermal protection circuit that will shut down the charge pump if the die temperature rises above the thermal limit, as is the case during a short circuit of the  $V_{OUT}$  pin.

### S<sup>2</sup>Cwire Serial Interface Timing

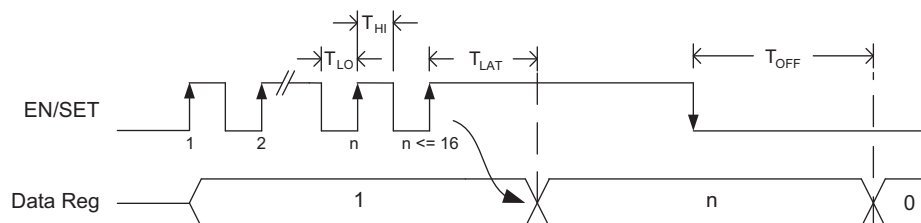

## Applications Information

### LED Selection

Although AAT3158 is specifically intended for driving white LEDs, the device can also be used to drive most types of LEDs with forward voltage specifications ranging from 2.0V to 4.7V. LED applications may include main and sub-LCD display backlighting, camera photo-flash applications, color (RGB) LEDs, infrared (IR) diodes for remotes, and other loads benefiting from a controlled output current generated from a varying input voltage. Since the D1 to D4 input current sinks are matched with negligible voltage dependence, the LED brightness will be matched regardless of the specific LED forward voltage ( $V_f$ ) levels. In some instances (e.g., in high-luminous-output applications such as photo flash), it may be necessary to drive high- $V_f$  type LEDs. The low dropout current sinks in the AAT3158 make it capable of driving LEDs with forward voltages as high as 4.7V at full current from an input supply as low as 3.0V. Outputs can be paralleled to drive high-current LEDs without complication.

### Device Switching Noise Performance

The AAT3158 operates at a fixed frequency of approximately 1MHz to control noise and limit harmonics that can interfere with the RF operation of cellular telephone handsets or other communication devices. Back-injected noise appearing on the input pin of the charge pump is 20mV peak-to-peak, typically ten times less than inductor-based DC/DC boost converter white LED backlight solutions. The AAT3158 soft-start feature prevents noise transient effects associated with inrush currents during start-up of the charge pump circuit.

### Capacitor Selection

Careful selection of the four external capacitors ( $C_{IN}$ ,  $C_1$ ,  $C_2$ ,  $C_{OUT}$ ) is important because they will affect turn-on time, output ripple, and transient performance. Optimum performance will be obtained when low equivalent series resistance (ESR) ceramic capacitors are used; in general, low ESR may be defined as less than 100m $\Omega$ . A value of 1 $\mu$ F for all four capacitors is a good starting point when

choosing capacitors. If the LED current sources are only programmed for light current levels, then the capacitor size may be decreased.

### Capacitor Characteristics

Ceramic composition capacitors are highly recommended over all other types of capacitors for use with the AAT3158. Ceramic capacitors offer many advantages over their tantalum and aluminum electrolytic counterparts. A ceramic capacitor typically has very low ESR, is lowest cost, has a smaller PCB footprint, and is non-polarized. Low ESR ceramic capacitors help maximize charge pump transient response. Since ceramic capacitors are non-polarized, they are not prone to incorrect connection damage.

### Equivalent Series Resistance

ESR is an important characteristic to consider when selecting a capacitor. ESR is a resistance internal to a capacitor that is caused by the leads, internal connections, size or area, material composition, and ambient temperature. Capacitor ESR is typically measured in milliohms for ceramic capacitors and can range to more than several ohms for tantalum or aluminum electrolytic capacitors.

### Ceramic Capacitor Materials

Ceramic capacitors less than 0.1 $\mu$ F are typically made from NPO or COG materials. NPO and COG materials typically have tight tolerance and are stable over temperature. Larger capacitor values are typically composed of X7R, X5R, Z5U, or Y5V dielectric materials. Large ceramic capacitors, typically greater than 2.2 $\mu$ F, are often available in low-cost Y5V and Z5U dielectrics, but capacitors greater than 1 $\mu$ F are typically not required for AAT3158 applications. Capacitor area is another contributor to ESR. Capacitors that are physically large will have a lower ESR when compared to an equivalent material smaller capacitor. These larger devices can improve circuit transient response when compared to an equal value capacitor in a smaller package size.

## ChargePump™ High Efficiency 1X/1.5X/2X Charge Pump for White LED Applications

### Ordering Information

Package	Marking <sup>1</sup>	Part Number (Tape and Reel) <sup>2</sup>
TSOPJW-12	RHXYY	AAT3158ITP-T1



All AnalogicTech products are offered in Pb-free packaging. The term “Pb-free” means semiconductor products that are in compliance with current RoHS standards, including the requirement that lead not exceed 0.1% by weight in homogeneous materials. For more information, please visit our website at <http://www.analogictech.com/aboutus/quality.php>.

### Package Information

TSOPJW -12

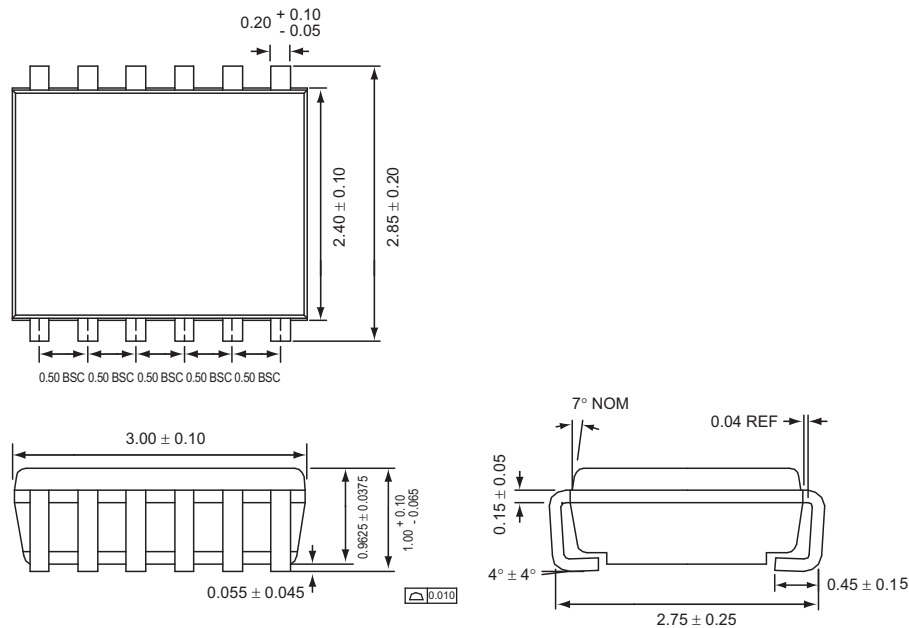

All dimensions in millimeters.

1. XYY = assembly and date code.
2. Sample stock is generally held on part numbers listed in **BOLD**.

**Advanced Analogic Technologies, Inc.**  
 3230 Scott Boulevard, Santa Clara, CA 95054  
 Phone (408) 737-4600  
 Fax (408) 737-4611



© Advanced Analogic Technologies, Inc. AnalogicTech cannot assume responsibility for use of any circuitry other than circuitry entirely embodied in an AnalogicTech product. No circuit patent licenses, copyrights, mask work rights, or other intellectual property rights are implied. AnalogicTech reserves the right to make changes to their products or specifications or to discontinue any product or service without notice. Except as provided in AnalogicTech's terms and conditions of sale, AnalogicTech assumes no liability whatsoever, and AnalogicTech disclaims any express or implied warranty relating to the sale and/or use of AnalogicTech products including liability or warranties relating to fitness for a particular purpose, merchantability, or infringement of any patent, copyright or other intellectual property right. In order to minimize risks associated with the customer's applications, adequate design and operating safeguards must be provided by the customer to minimize inherent or procedural hazards. Testing and other quality control techniques are utilized to the extent AnalogicTech deems necessary to support this warranty. Specific testing of all parameters of each device is not necessarily performed. AnalogicTech and the AnalogicTech logo are trademarks of Advanced Analogic Technologies Incorporated. All other brand and product names appearing in this document are registered trademarks or trademarks of their respective holders.