

TOSHIBA Bi-CMOS Integrated Circuit Silicon Monolithic

TB9068FG

3phase DC Brushless Motor Driver with LIN Driver and 5V Regulator

TB9068FG is a Small size 3-Phase DC Brushless Motor Controller LSI for Automotive which use ether external HALL sensor or HALL IC for Motor position detection and can directly drive a Motor. For external MCU the TB9068FG build-in 5V Regulator, Watchdog Timer and a LIN Bus transceiver. TB9068FG provide 2 type operation Modes. one mode is to control Motor by Built-in LOGIC controller for 120deg, Square operation The other mode is to control Motor by external MCU which can achieve complicated Motor control.

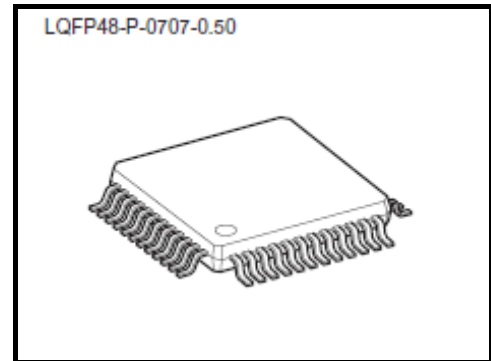

Weight: 0.189 g (Typ.)

Features

- MOTOR Drive
 - 120deg. Square wave operation by internal LOGIC controller (MODE0)
 - : Motor drive signal is made by internal LOGIC.
 - Rotation control (CCW/CW), PWM (L-side) INPUT, BRAKE control INPUT
 - MCU controlled Operation (MODE1)
 - : MOTOR control signal by 6 INPUT and PWM by MCU.

- Half Bridge Driver: 3ch Built-in

- Various Abnormal Detection circuits and Diagnostics output.
 - : Over Current Detection / Over Temp. Detection / Over Voltage Detection

- On-chip 5V regulator
 - Output Voltage 5.05V (typ.)
 - Current Limiter : Limit current is adjusted by external resistor
 - RESET Function: Under Voltage Detection for 5V / Power On RESET / Watch Dog Timer

- LIN Transceiver: Ver. 1.3 based

- Operating Voltage range: 7~18V

- Operating TEMP. range: -40°C~125°C

- Built-in CR Oscillator (4MHz)

- Package: LQFP-48pin (0.5mm pitch)

INTERNAL BLOCK DIAGRAM AND PIN LAYOUT

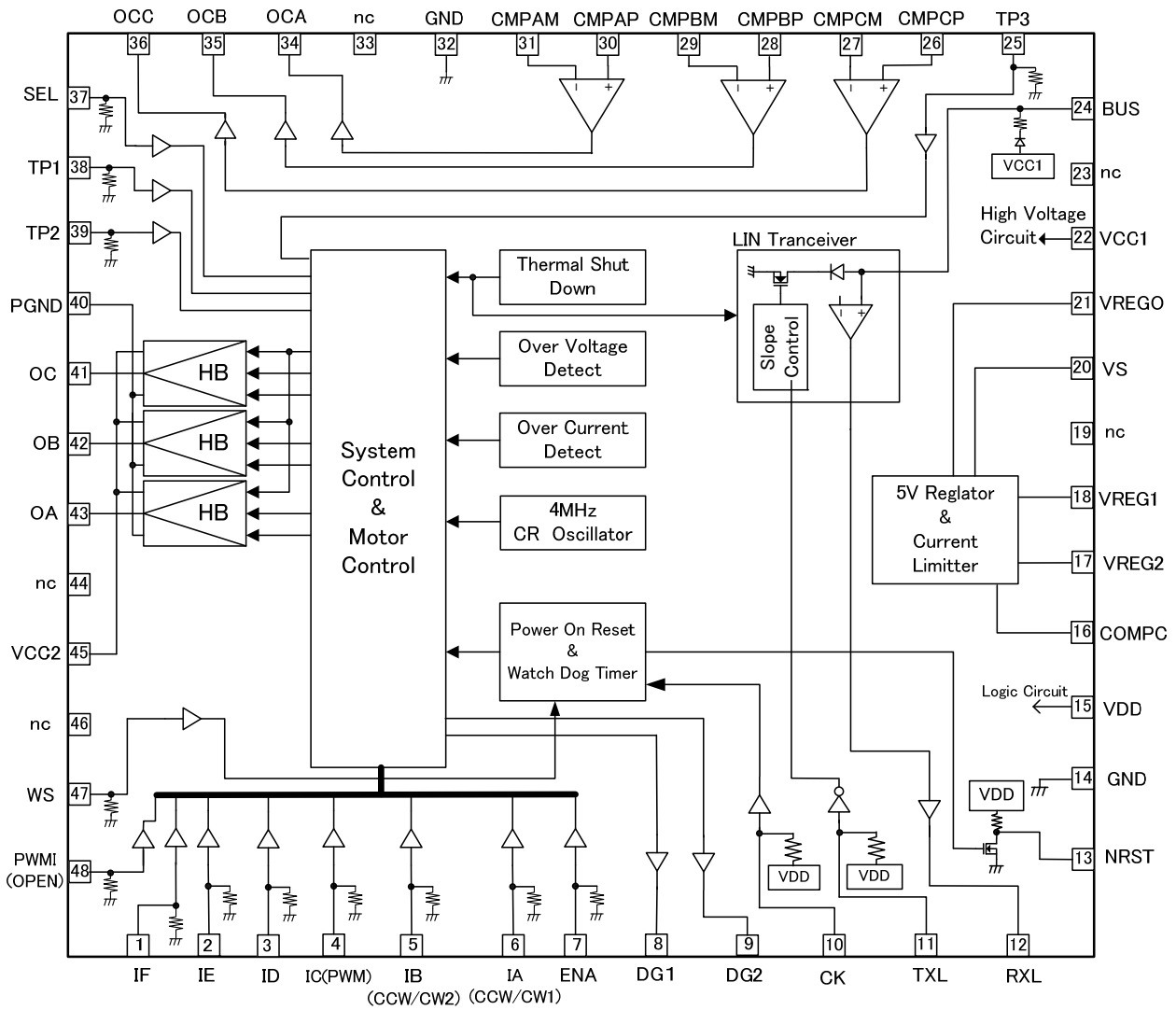

- HB: Half Bridge Driver
- nc: No internal connection PIN (open in CHIP)
- PWMI (open): External PWM Input for MODE1. Keep open in MODE0
- IC(PWM): External PWM Input in MODE0. Motor control Input signal in MODE1
- IA(CCW/CW1): Motor rotation direction control in MODE0. Motor control Input signal in MODE1
- IB(CCW/CW2): Motor rotation direction control in MODE0. Motor control Input signal in MODE1
- Slope Control: Slope control circuit for LIN driver to keep LIN ver.1.3 Slope Spec.

【CAUTION】 Some of the functional blocks,circuit,or constants in the block diagram may be omitted or simplified for explanatory purpose.

PIN CONNECTION

PIN No	PIN NAME	DEFINITION	IN / OUT	CIRCUIT	NOTES
1	IF (SC)*	MOTOR control signal input (SC HALL sensor signal input)*	IN	CMOS	120kΩ Pull Down
2	IE (SB)*	MOTOR control signal input (SB HALL sensor signal input)*	IN	CMOS	120kΩ Pull Down
3	ID (SA)*	MOTOR control signal input (SA HALL sensor signal input)*	IN	CMOS	120kΩ Pull Down
4	IC (PWM)*	MOTOR control signal input (PWM control signal input)*	IN	CMOS	120kΩ Pull Down
5	IB (CCW/CW2)*	MOTOR control signal input (MOTOR rotation control input2)*	IN	CMOS	120kΩ Pull Down
6	IA (CCW/CW1)*	MOTOR control signal input (MOTOR rotation control input1)*	IN	CMOS	120kΩ Pull Down
7	ENA (NBRAKE)*	MOTOR control signal enable input(BRAKE control signal input)*	IN	CMOS	50kΩ Pull Down
8	DG1	Diagnostic signal output 1	OUT	CMOS	
9	DG2	Diagnostic signal output 2	OUT	CMOS	
10	CK	Input signal to detect WATCH DOG error	IN	CMOS	50kΩ Pull Up
11	TXL	LIN input signal from MCU	IN	CMOS	50kΩ Pull Up
12	RXL	LIN output signal to MCU	OUT	CMOS	
13	NRST	RESET output signal	OUT	NMOS	10kΩ Pull Up
14	GND	Ground			Ground
15	VDD	Power input for CMOS LOGIC			
16	COMPC	Terminal of Capacitor for phase compensation	OUT	Bip	
17	VREG2	5V monitor input	IN	Bip	connected VREG1 and VREG2 in CHIP
18	VREG1	5V monitor input	IN	Bip	connected VREG1 and VREG2 in CHIP
19	nc				keep open
20	VS	Monitor input terminal for current of 5V Regulator.	IN	Bip	70kΩ(VS-VREGO)
21	VREGO	Outside PNP Tr. control output signal	OUT	Bip	
22	VCC1	Power input for ANALOG			
23	nc				keep open
24	BUS	LIN BUS terminal	IN/ OUT	Bip/ HVC MOS	30kΩ Pull Up

* “()” pin description in brackets are in MODE0, in case they are different from MODE 1.

PIN CONNECTION (cont.)

PIN No	PIN NAME	DEFINITION	IN / OUT	CIRCUIT	NOTES
25	TP3	TEST enable input	IN	CMOS	50kΩ Pull Down keep open
26	CMPCP	C comparater input signal (+)	IN	Bip	operation at 5V
27	CMPCM	C comparater input signal (-)	IN	Bip	
28	CMPBP	B comparater input signal (+)	IN	Bip	
29	CMPBM	B conparater input signal (-)	IN	Bip	
30	CMPAP	A comparater input signal (+)	IN	Bip	
31	CMPAM	A comparater input signal (-)	IN	Bip	
32	GND	Ground			ground
33	nc				keep open
34	OCA	A comparater output signal	OUT	CMOS	operation at 5V
35	OCB	B comparater output signal	OUT	CMOS	
36	OCC	C comparater output signal	OUT	CMOS	
37	SEL	MODE select input	IN	CMOS	50kΩ Pull Down
38	TP1	TEST input	IN	CMOS	50kΩ Pull Down keep open
39	TP2	TEST input	IN	CMOS	50kΩ Pull Down keep open
40	PGND	MOTOR drive Ground			
41	OC	MOTOR drive output signal C	OUT	Bip /HVMOS	RonH = 1Ω (Typ.) RonL = 1Ω (Typ.)
42	OB	MOTOR drive output signal B	OUT	Bip /HVMOS	
43	OA	MOTOR drive output signal A	OUT	Bip /HVMOS	
44	nc				keep open
45	VCC2	Battery power input terminal			
46	nc				keep open
47	WS	WATCH DOG TIMER enable input signal	IN	CMOS	50kΩ Pull Down
48	PWMI (open)	PWM signal input in MODE1 keep open in MODE0	IN	CMOS	120kΩ Pull Down keep open in MODE0

HVMS: Pch, Nch MOS work at VCC2

CMOS: Pch, Nch MOS work at 5V

FUNCTIONAL DESCRIPTION

(1) 5V Regulator Circuit and Current Limiter Circuit

The on-chip linear 5V regulator is designed to operate an external series PNP power transistor to grant thermal stability over a wide range of car battery voltages. The phase compensation capacitor is placed between PIN "COMPC" and collector of the external PNP Tr. A wide range of output currents can be realized by choosing an appropriate external PNP transistor. The maximum base current output is about 1 mA.

The current is controlled via sense resistor between "VS" and "VCC1". When voltage across the sense resistor exceed VLIMIT then the terminal "VREGO" is OFF and cut the current to keep the constant output voltage of 5V regulator. It keeps the output alive but limiting to the maximum allowed current trying to keep an external MCU alive even if there is a problem with over current. It is possible to disable the over current detection by connecting "VS" and "VCC1" directly.

Detected Current: $i = (VCC1 - VLIMIT) / R$ VLIMIT: VCC1-0.4V~VCC1-0.15V

【CAUTION】

- Make sure driver output "VREGO" is correctly connected to the Base of external PNP. In case this terminal is for example connected to GND the LSI can not work properly and in worst case may be destroyed.
When the terminal BASE of this Tr. is connected or shorted to VCC1, outside PNP Tr. Is OFF and output voltage of Regulator is OFF.
- Connecting PIN "VS" to VCC1, VCC2 or GND will make damage the LSI.
- In case the PIN "COMPC" is shorted to VCC1, it will cause LSI damage. And when it is shorted to GND the 5V Regulator cannot work properly.
- When PIN "VREG1", "VREG2" are open, outside PNP Tr. cannot be controlled properly and output Voltage of PIN "VREG" can exceed 5V. And in worst case destroying the 5V LOGIC. When power is supplied to LSI, please double-check if the collector of outside PNP Tr. is connected to PIN "VREG" properly.

(2) RESET Circuit (see the following timing charts)

1. 5V Low Voltage Detection (Power On RESET)

This function detects if Output voltage of 5V Regulator has dropped below certain threshold level using the internal BAND GAP as reference.

For system stability a hysteresis voltage was set-up between the RESET detection voltage (VRSTL) and RESET cancelation voltage (VRSTH).

Even when using an external voltage regulator it's 5V output is controlled by comparing to the internal high quality BAND GAP reference.

2. Power On RESET Timer and WATCH DOG TIMER (at internal OSC 4MHz)

Output Pin “NRST” will output “L” 25ms (typ) after power ON or during WATCH DOG Timer released RESET signal.

And after RESET is canceled, PIN “NRST” outputs H which is thru internal Pull Up Resistor (10KΩ). After Power ON RESET (PIN ”WS”=L) is canceled, system changes to WATCH DOG TIMER MODE and waits for an input signal from PIN ”CK” for 50ms.(=TWD Typ.).

If the signal from PIN “CK” did not occur during TWD, PIN “NRST” changes output to L for about 5ms (TRST).

3. WATCH DOG TIMER (at internal OSC 4MHz)

TB9068FG has a built-in WATCH DOG TIMER (WDT). This function can be enabled/disabled by PIN “WS”.

WS = L: WDT enable

WS = H: WDT disable (but Power ON RESET work independently)

When WDT is enabled (WS=L), it waits for an activity signal from the MCU at the input PIN “CK”. When this signal does not change during 50ms (Typ.), PIN “NRST” outputs L for 5ms (Typ.). After that WDT restarts to count the time.

(PIN “NRST” circuit configuration and diagram)

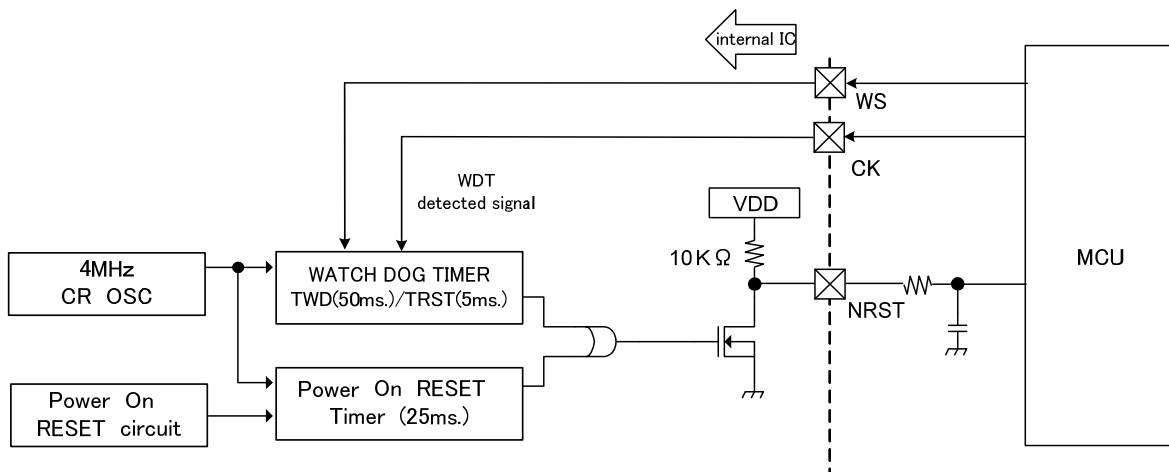

(WDT Timing chart)

(WDT enable: WS=L)

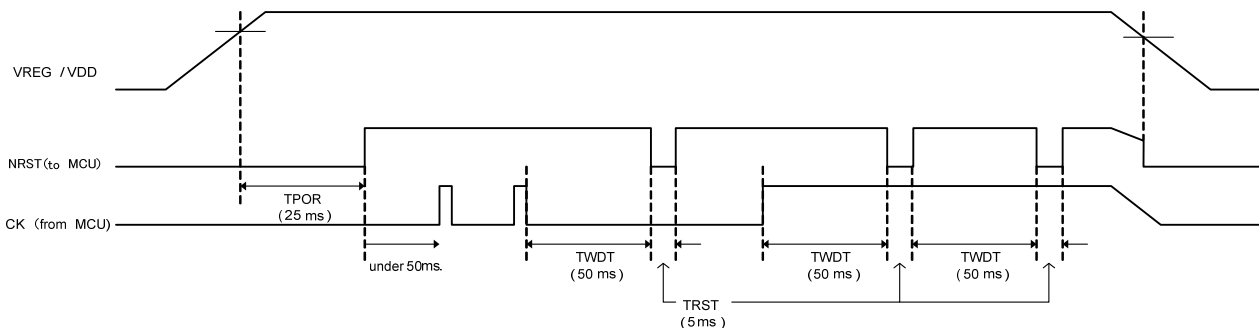

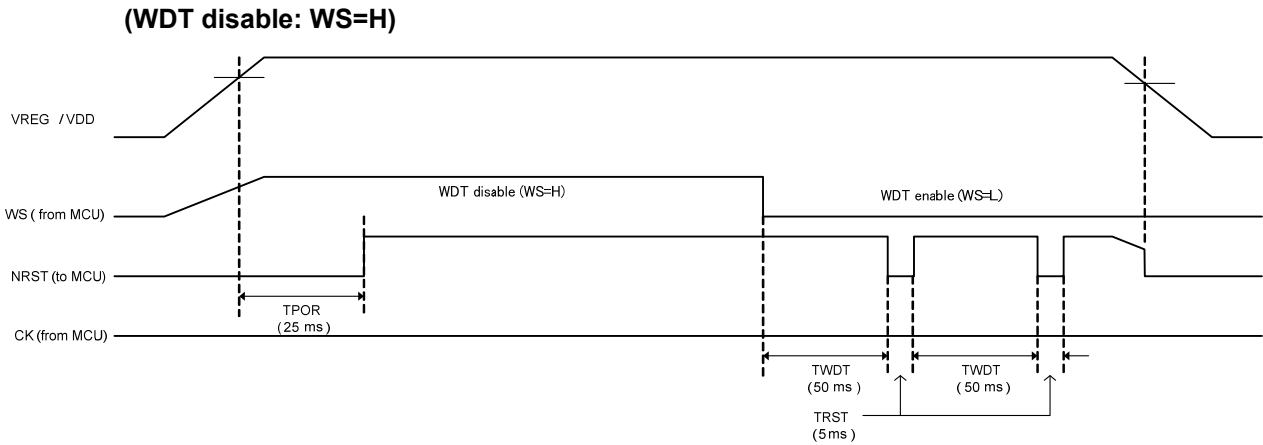

(3) 4MHz INTERNAL CR OSCILLATOR

TB9068FG has a built-in 4MHz CR Oscillator which is operated from the internal stable 5V voltage. This clock is used for all internal timing purposes.

(4) DIAGNOSTIC CIRCUIT (DG1,DG2)

TB9068FG has the Over Current / Over Voltage / Over Temperature Detection Circuit with a diagnostic monitor output “DG1” and “DG2”. Each failure detected can be noticed by output pins “DG1” and “DG2” change to H as follows. When respective condition has come to an end (return to normal), each output pin return to L (Normal).

PIN “DG1”	PIN “DG2”	Detected abnormal
L	L	normal
H	—	detect Over Current
—	H	detect Over Temperature or Over Voltage
H	H	detect Over Current, Over Temperature or Over Voltage

“—” : no relation

1. OVER VOLTAGE DETECTION (VCC1)

When VCC1 is over 27V(Typ.), MOTOR Drivers are stopped (OFF, Hi-Z) and PIN “DG2” outputs H. As soon as VCC1 drops under 27V(Typ.) MOTOR Driver returns to normal output and PIN “DG2” outputs L.

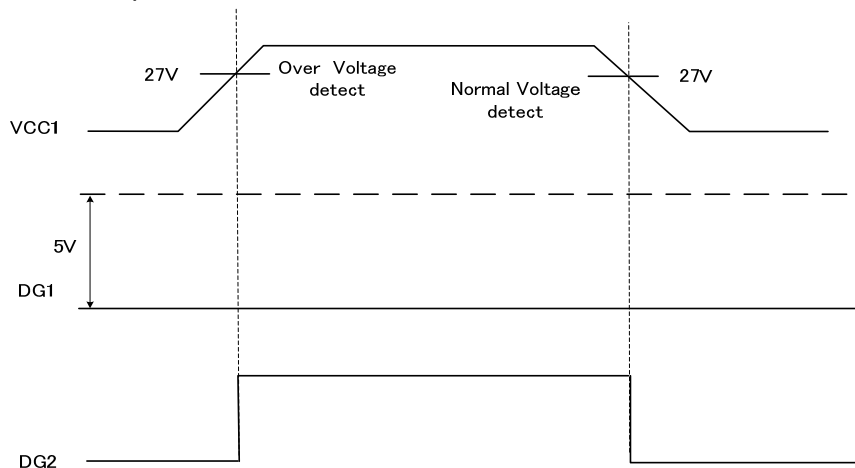

* The above is the case to detect only Over Voltage (DG1=L,DG2=H)

[CAUTION] This Over Voltage Detection is not to clamp Battery Voltage for TB9068FG. Thus, the system should keep lower operation voltage than the Max. rating Spec.

2. OVER TEMPERATURE DETECTION

When the junction temperature exceeds 150°C(min.), the MOTOR drivers are OFF (Hi-Z), LIN driver is OFF (Hi-Z) and PIN “DG1” output is H. When the temperature of the CHIP drops under 140°C(min.), MOTOR driver return to normal and PIN “DG2” outputs L.

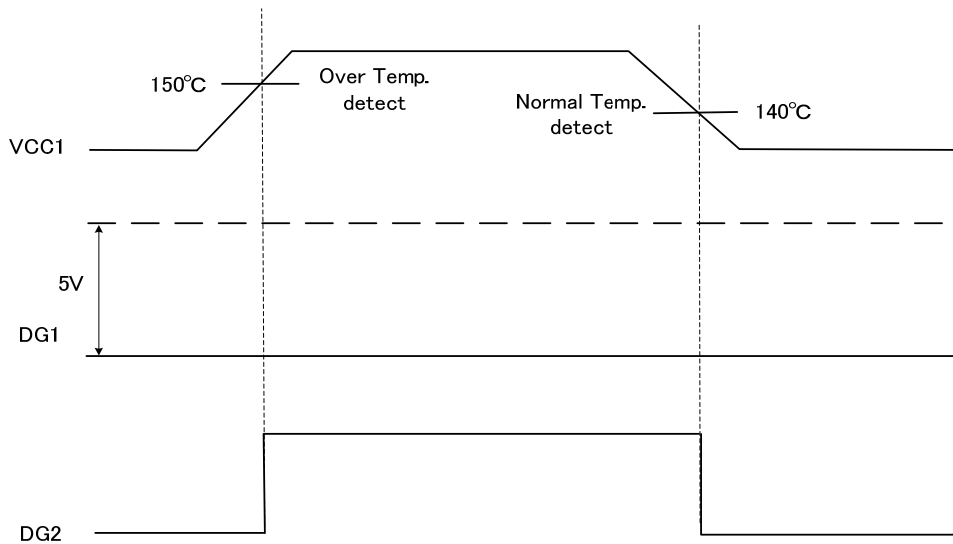

The above is the case to detect only Over Temperature (DG1=L,DG2=H)

[CAUTION] The Absolute maximum Temperature of TB9068FG is 150deg. This Over Temperature Detection function does not intend to limit the CHIP temperature. Thus, the above Absolute Maximum Temperature never is over to use TB9068FG. If any of these rating would be exceeded during operation, the device electrical characteristics may be irreparably altered and the reliability and lifetime of the device can no longer be guaranteed. Moreover, these operations with exceeded ratings may cause break down, damage and/or degradation to any other equipment. Applications using the device should be designed such that each maximum rating will never be exceeded in any operating conditions. Before using, creating and/or producing designs, refer to and comply with the precautions and conditions set forth in this documents.

This Over Temp. Detection is worded over the Max. Rating Temperature and shipping test does not perform at the Max. Rating Temp.

3. OVER CURRENT DETECTION

When MOTOR driver current exceeds $\pm 1.5A$ (min.), the MOTOR drivers are OFF (Hi-Z) and PIN “DG1” outputs H. Over current detection is not reset even when current falls to uncritical value and PIN “DG1” remains at H-level. To reset the Over Current condition a LOW pulse at PIN “ENA(NBLAKE)” is needed. Over current reset actually happens during rising edge of the reset pulse and motor drivers are turned ON and PIN “DG1” returns to L. If however during reset pulse still over current ($> \pm 1.5A$) is detected the over current will remain and not be reset.

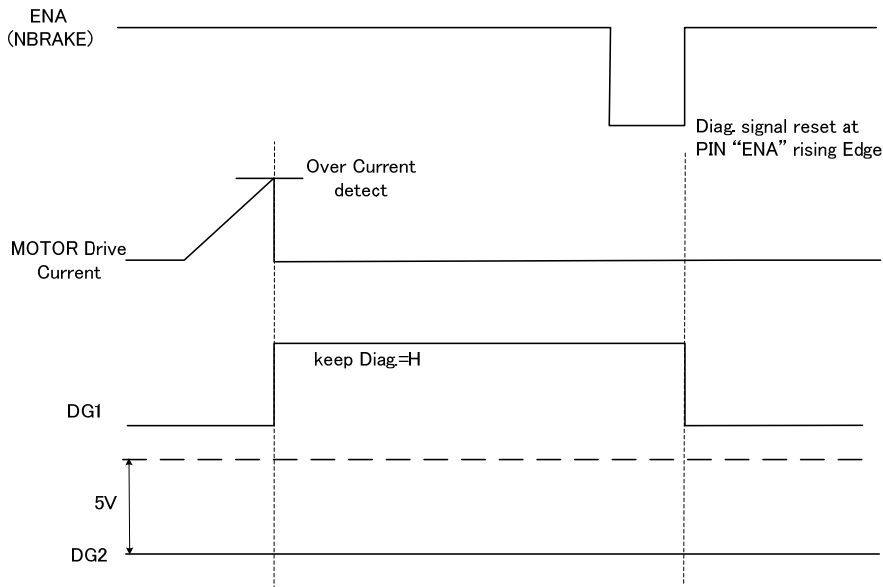

The above is the case to detect only Over Current (DG1=H,DG2=L)

[CAUTION] Over current detection $\pm 1.5A$ (min.) is based on overall motor current:

**Detected Current = the output current of PIN “OA”
 + the output current of PIN “OB”
 + the output current of PIN “OC”**

[CAUTION] In MODE0, Motor Driver off(Hi-Z) by Abnormal Detection is higher priority than brake function by PIN”ENA(NBRAKE)” or PIN”IA(CCW/CW1)” .

(5) MODE SELECTION for MOTOR CONTROL

TB9068FG has 2 modes for MOTOR control which are selected by PIN "SEL" as follows

1. MODE0 (SEL=L or open)

(for 3PHASE BRUSHLESS MOTOR 120deg. Square wave operation with HALL sensor)

The sensor signals which is input at PINs "ID(SA)", "IE(SB)" and "IF(SC)" are processed by the internal LOGIC and corresponding MOTOR control outputs are available at PINs "OA", "OB", "OC". PWM (L-side) MOTOR speed control is available by applying low frequency PWM at the input PIN "IC (PWM)".

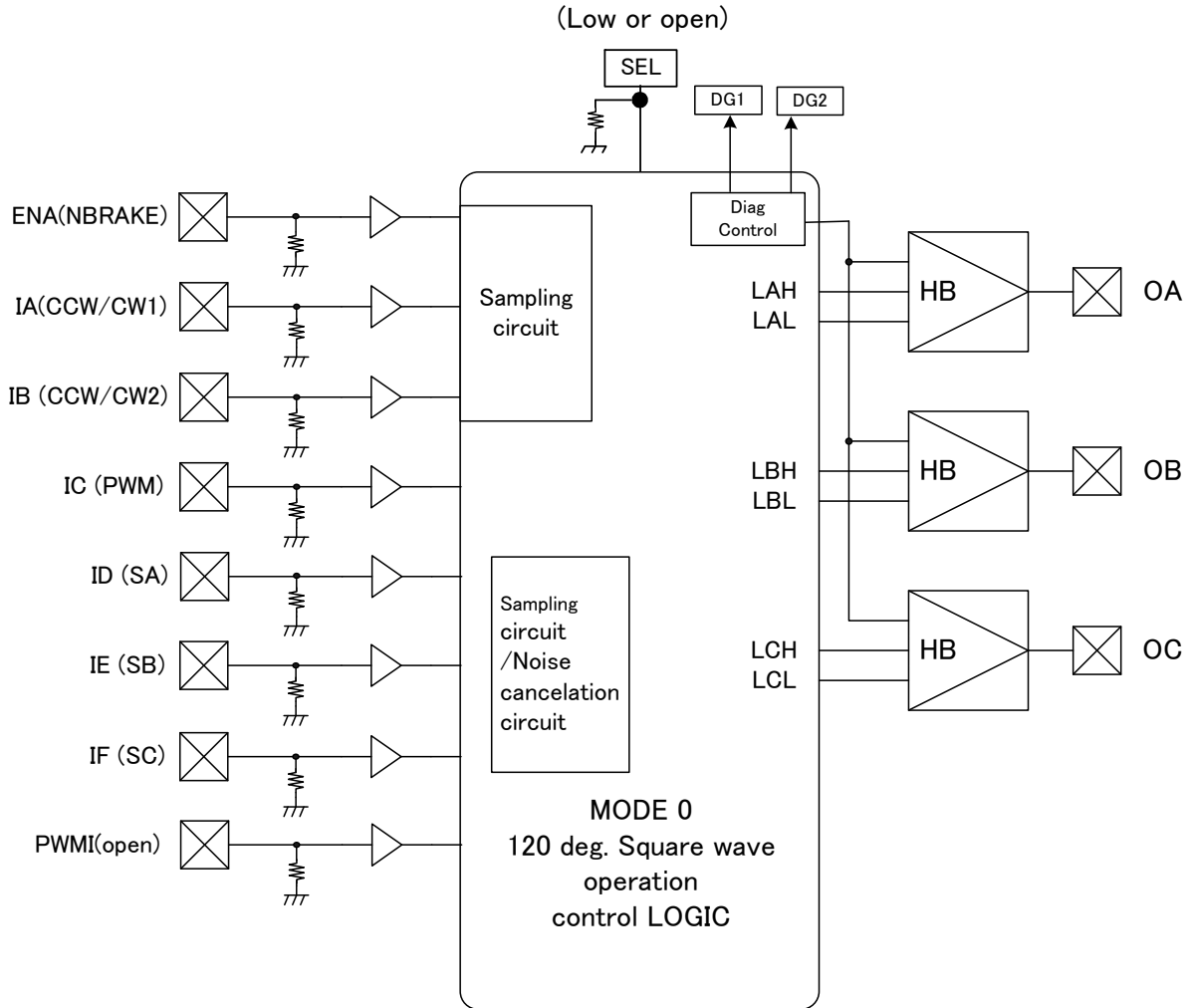

In MODE0, PIN "IB", "PWMI" need to be kept OPEN

(The equivalent circuit of MOTOR driver)

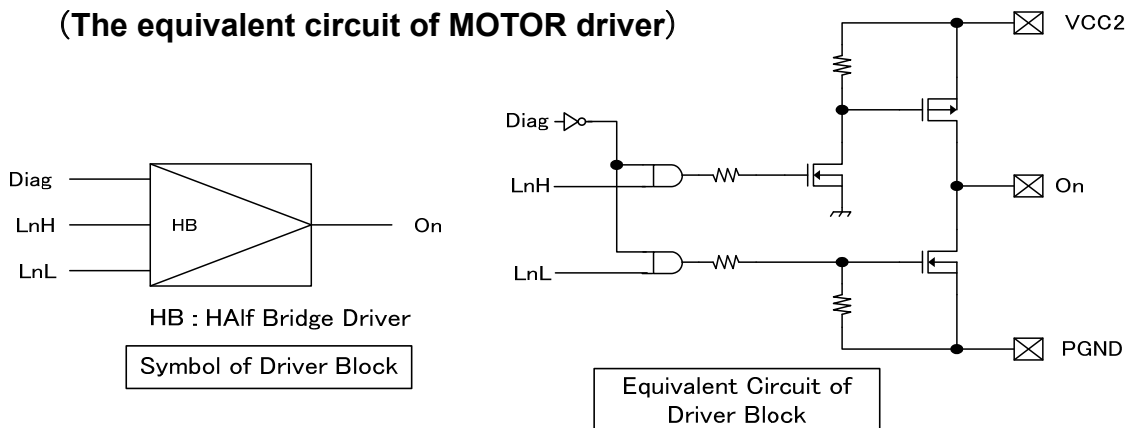

(DRIVER TIMING CHART)

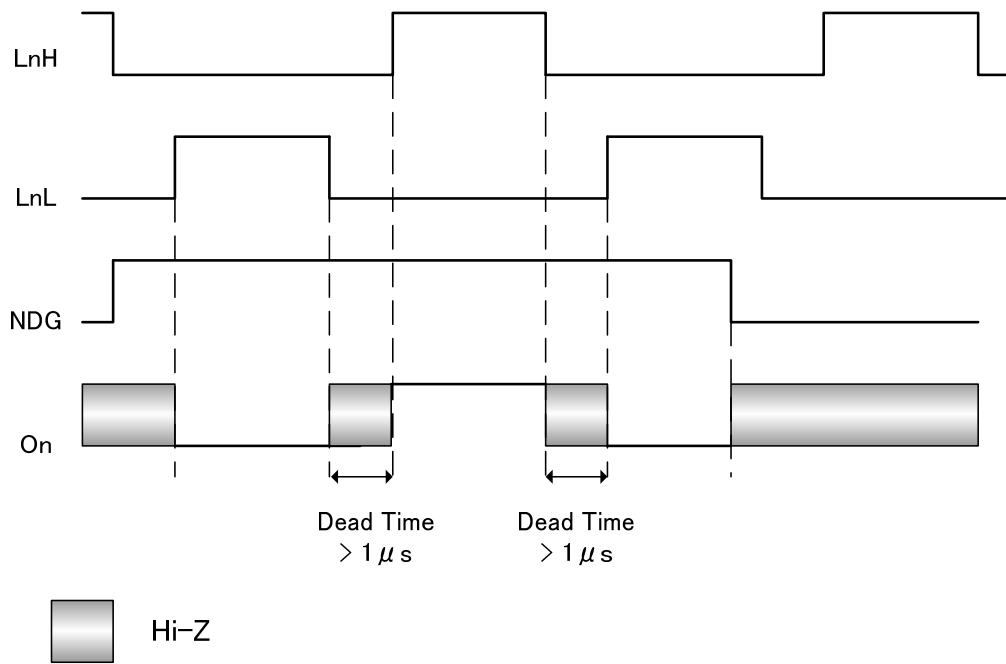

(DRIVER TIMING CHART at PWM CONTROL)

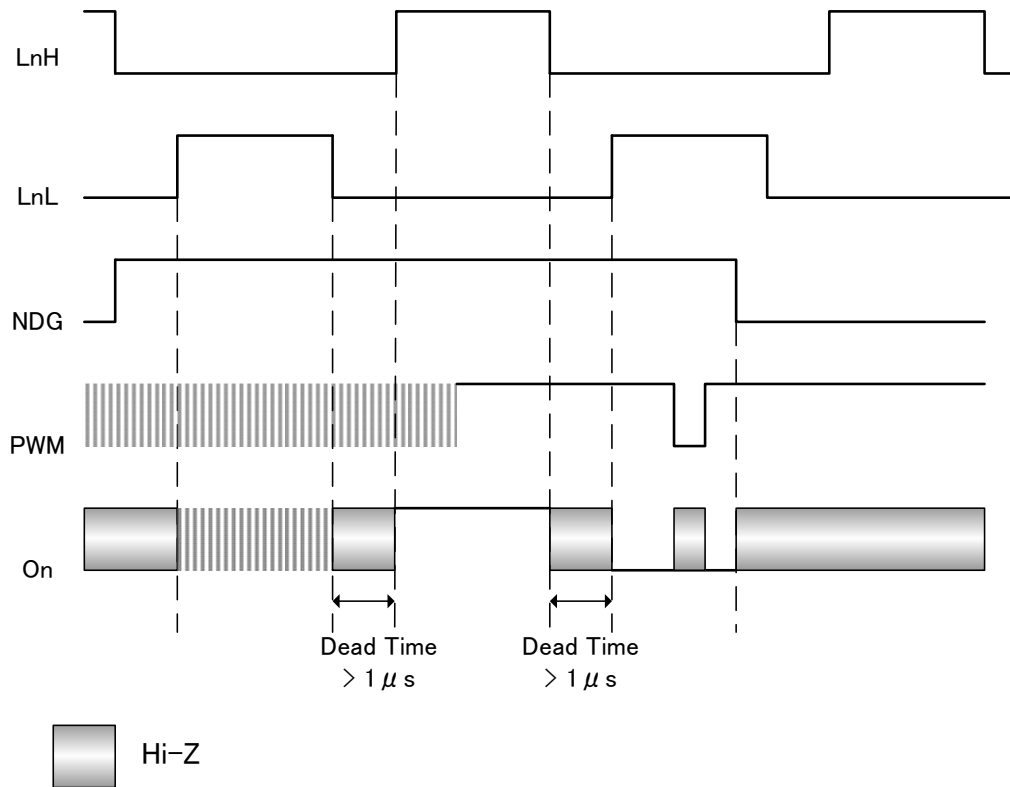

(120deg. Square wave Operation Motor control at 4MHz)

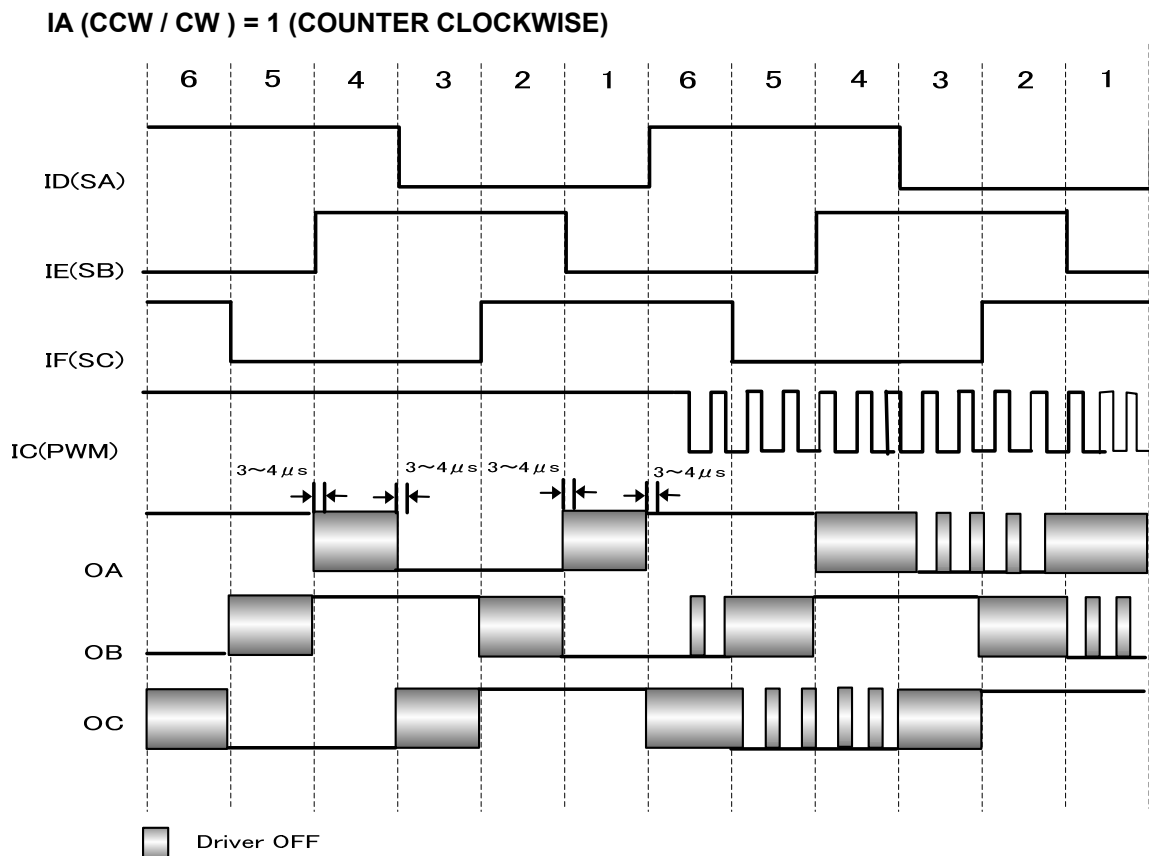
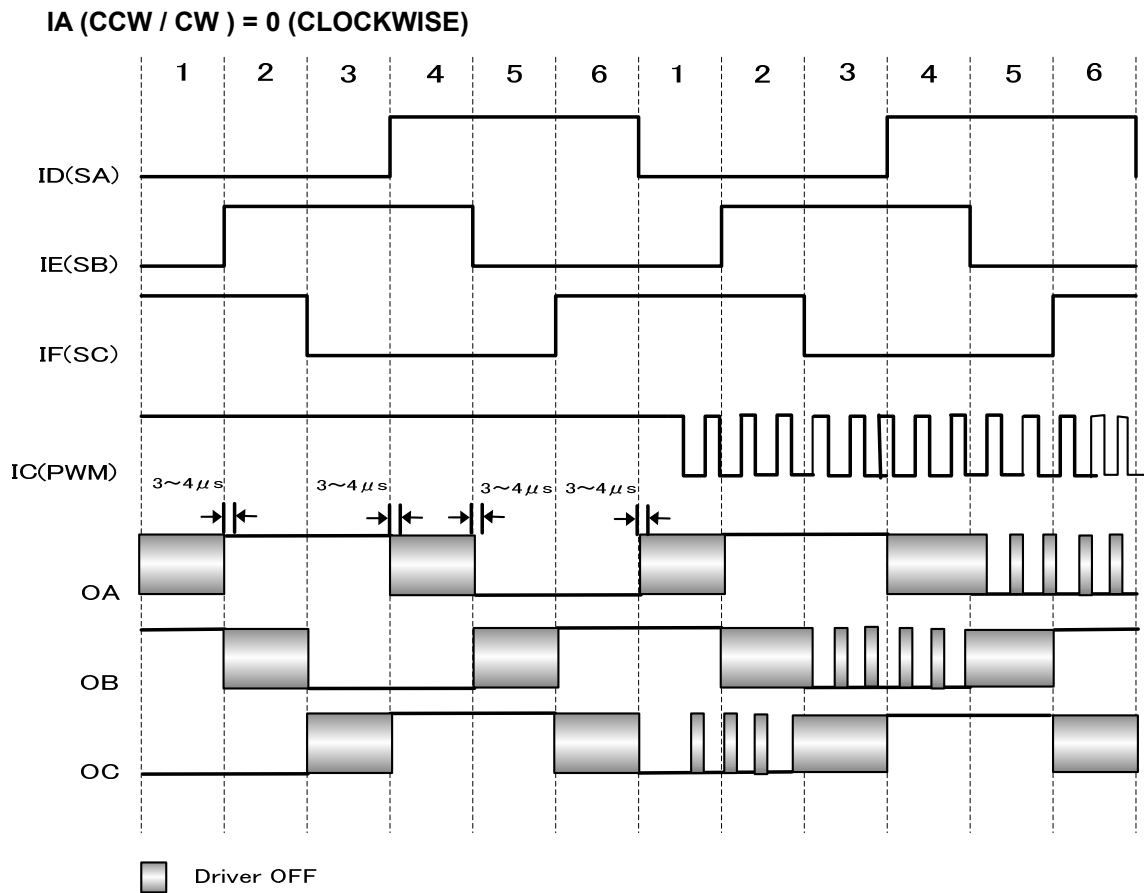

The HALL sensor signals are processed by the internal LOGIC to detect the rotor position. Internal Noise Canceler ignores sensor signals shorter than 2-3μs(Typ. at OSC 4MHz). This delay between the input of sensor and output of Motor driver include driver transistor switching delay. In MODE0 which provide 120deg. Square wave operation does not set DEAD TIME to protect short current between Pch and Nch simultaneous ON. In normal sequence of 120deg. Square wave operation, there is no direct switching of Motor driver between H and L. Only in case of Motor driver ON/OFF by Input "ENA(NBRAKE)", the Hi-Z status of Motor driver for 1us is set.

(Changing rotation direction by PIN "IA(CCW/CW1)" and "IB(CCW/CW2)" in MODE 0)

The Motor rotation direction is controlled by the inputs "CCW/CW1" and "CCW/CW2" in MODE0, as follows.

PIN "IA(CCW/CW1)"	PIN "IB(CCW/CW2)"	OPERATION
L	L	BRAKE (L-side ON)
H	L	CCW (Reverse)
L	H	CW (Forward)
H	H	Free (H/L-side OFF)

When the MOTOR rotation direction is changed by the input "CCW/CW1" and "CCW/CW2", firstly a braking operation (input "CCW/CW1"="CCW/CW2"= L) is required. At each edge of "CCW/CW1" and "CCW/CW2" Motor driver outputs are OFF(Hi-Z) for 1us.(Typ. at OSC 4MHz). (see the follows)
 If the input "ENA(NBRAKE)" is L when driver outputs return to normal by "IA"=H or "IB"=H, driver outputs wait until input "EAN(NBRAKE)" become H.

(CCW/CW1=CCW/CW2=L: Braking OA=OB=OC=L)

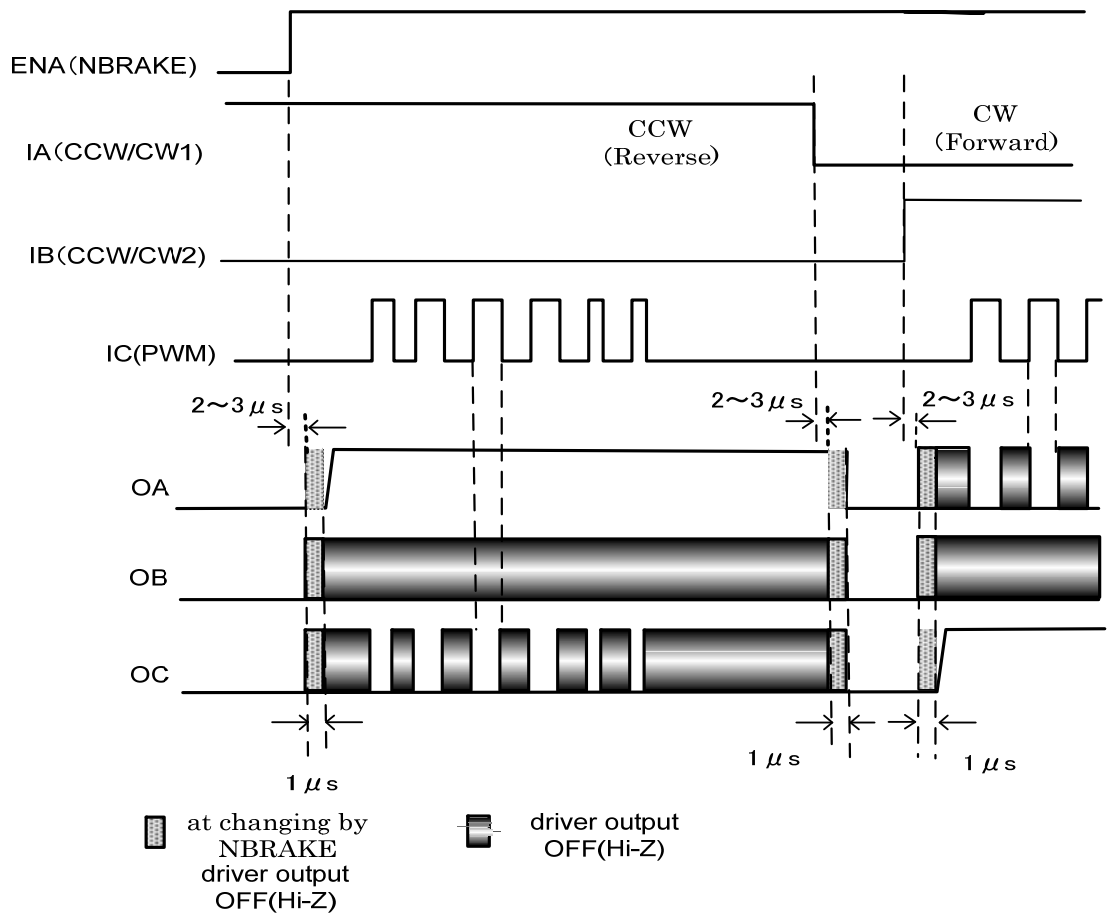

(CCW/CW1=CCW/CW2=H: Free OA=OB=OC=Hi-Z)

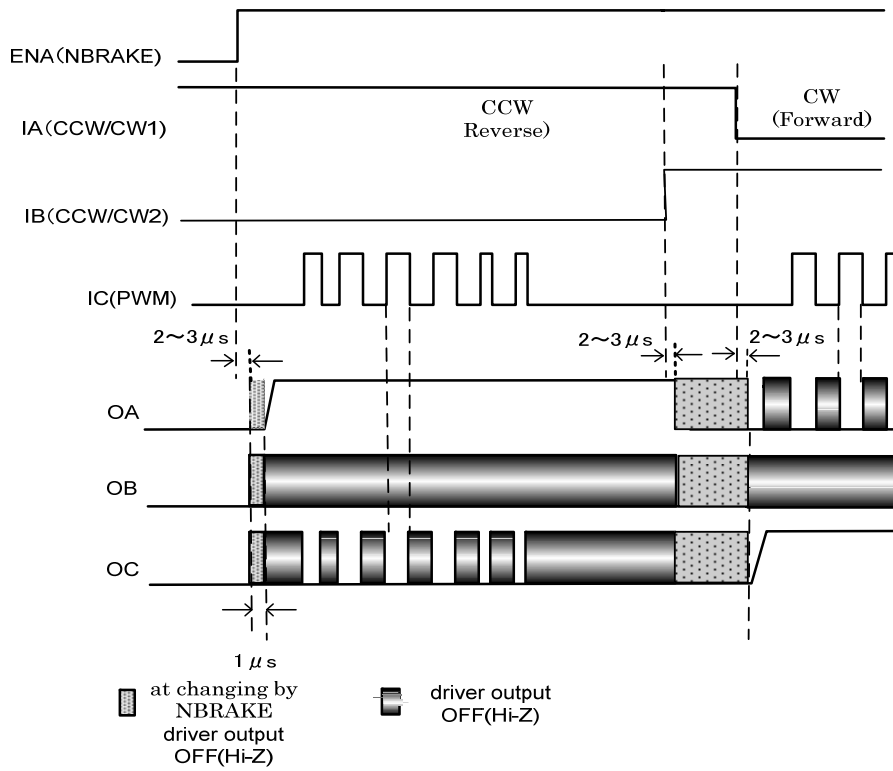

When "CCW/CW1"="CCW/CW2"=H, each motor driver outputs are OFF(Hi-Z). And after detecting CCW/CW1=L or CCW/CW2=L, each driver output the signal according to CCW/CW1 and CCW/CW2.

(Rotation change at "ENA(BRAKE)=L)

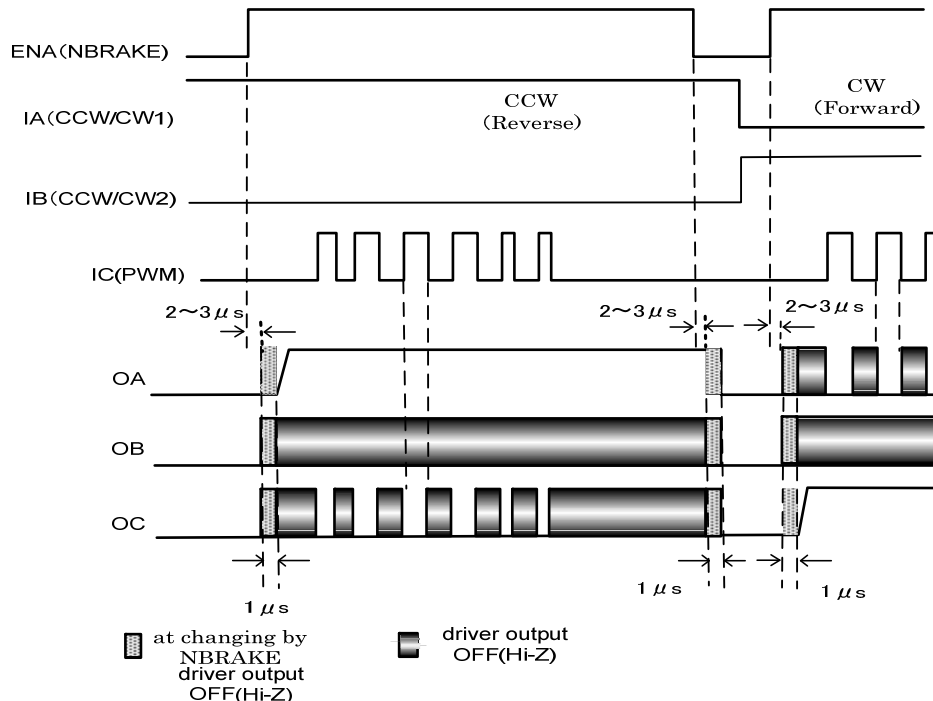

Before Motor rotation direction is changed, once being Brake by PIN"PWMI"=0 and "ENA(NBRAKE)"=0 is recommendation. When "ENA(NBRAKE)" is changed, Motor Driver is off(Hi-Z) during 1µs(at 4MHz)

2. MODE1 (SEL=1) (for 3PHASE BRUSHLESS MOTOR control by MCU)

The MOTOR driver output signal is controlled by outside MCU. When the PWM speed control is required, MCU needs to generate and output the MOTOR control signals with PWM pattern. or independently input PWM signal from input terminal "PWMI" In MODE1, TB9068FG does not generate the DEAD TIME. Therefore, MCU needs to control that short circuit current thru the driver Pch and Nch can not happen(avoid simultaneous occurrence of IA>ID=H, IB=IE=H, IC=IF=H).

Each Motor driver output OA,OB,OC has the delay around 0.2 - 1.0us against each input signal IA - IF.

High Side cont. Input	Low Side cont. Input	output
IA	ID	OA
IB	IE	OB
IC	IF	OC

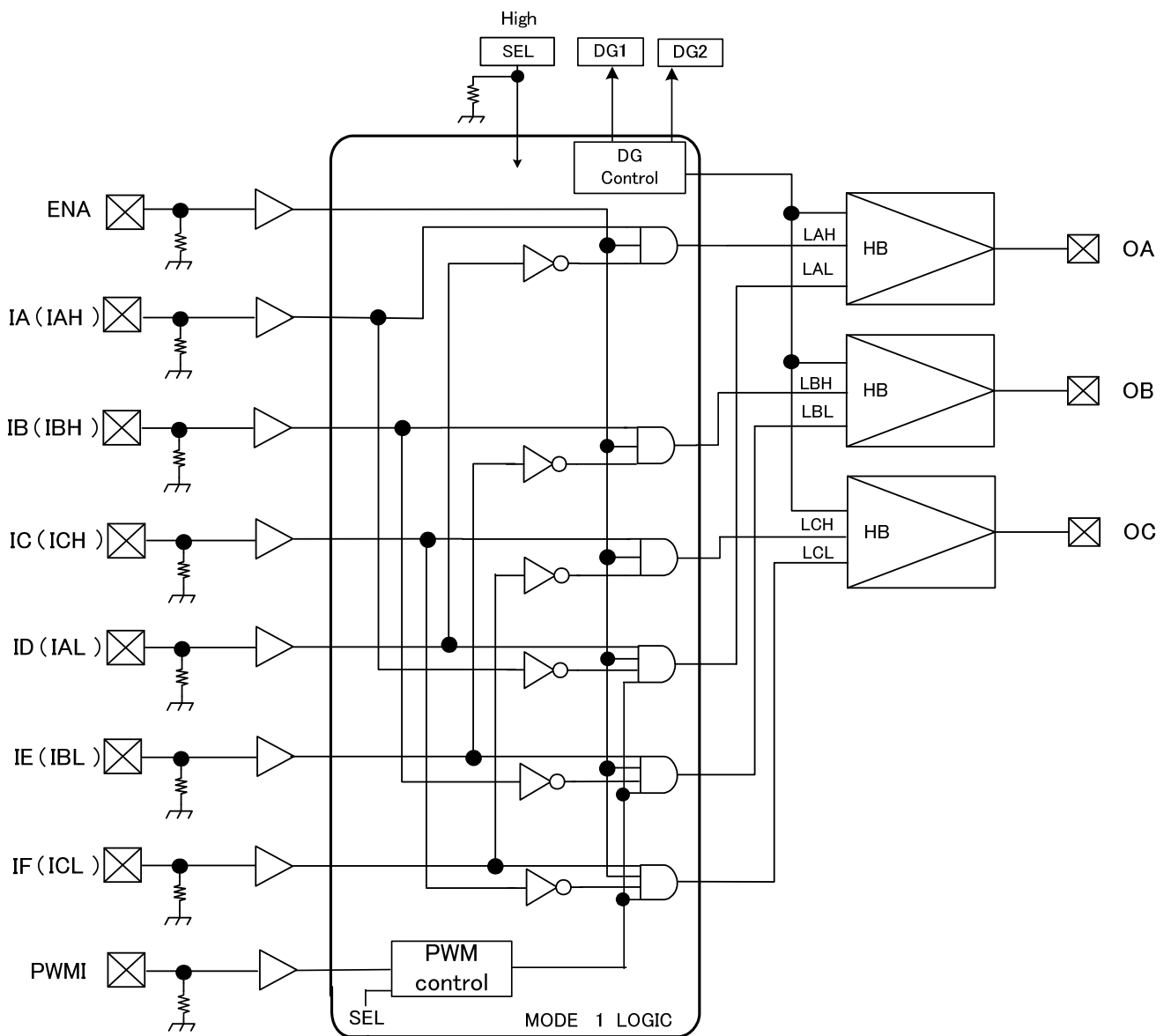

(TIMING CHART of MOTOR DRIVE OUTPUT SIGNAL in MODE1)

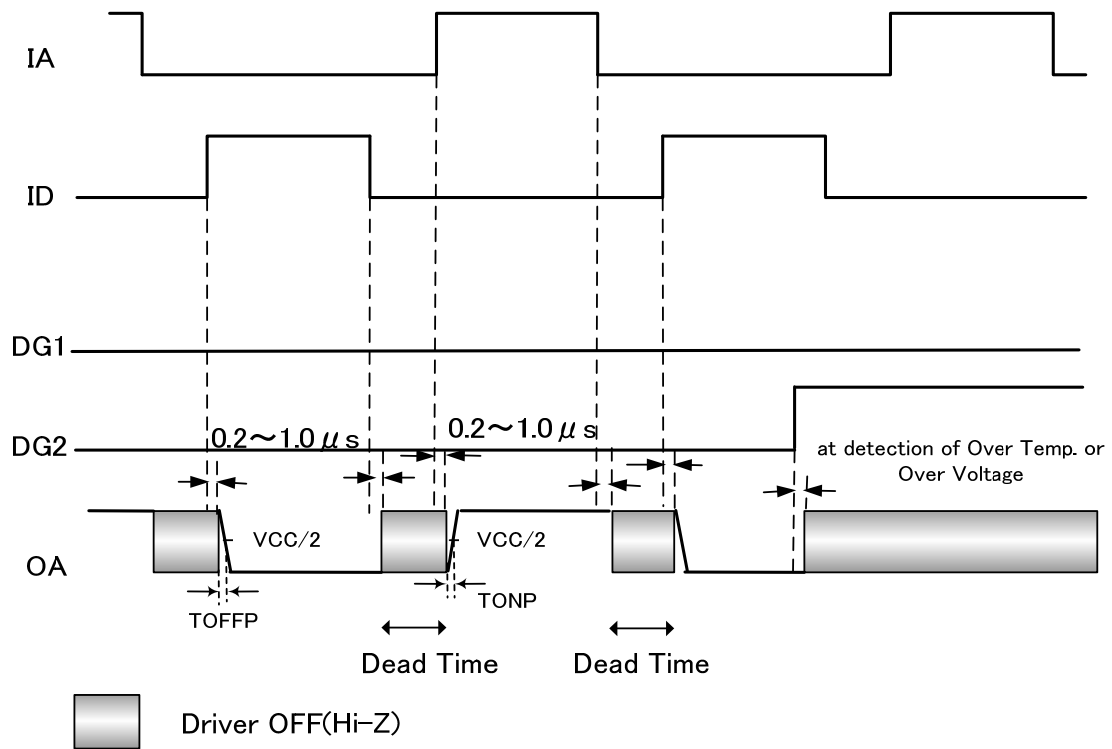

(MOTOR CONTROL SIGNAL and MOTOR DRIVE SIGNAL in MODE1)

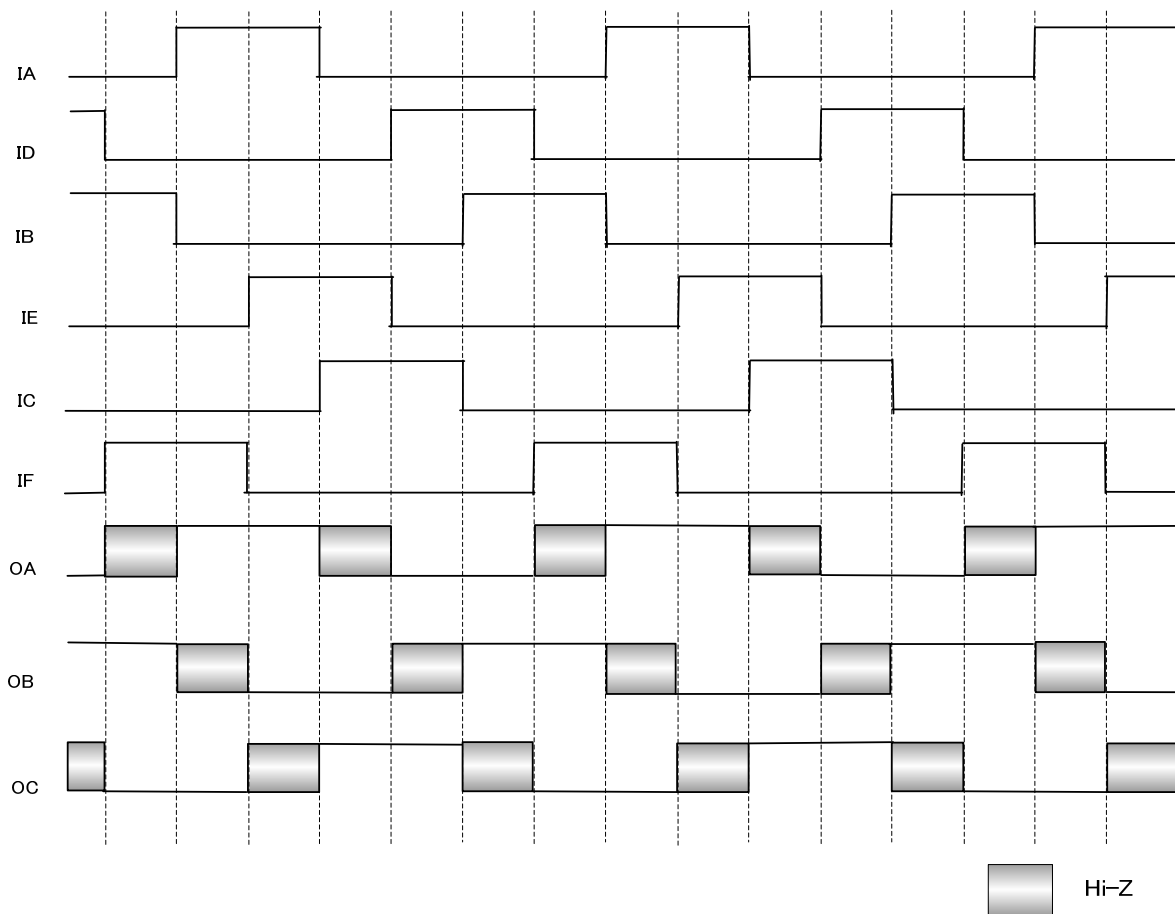

(6) INTEGRATED ANALOG COMPARATOR for HALL SENSOR

TB9068FG has integrated Analog Comparators for HALL Sensors to detect the MOTOR position. These Analog Comparators convert the analog HALL Sensor output signals into Digital signal pulses. In MODE0, once 3 HALL Sensor signals are input to PINs "CMPAP", "CMPAM", "CMPBP", "CMPBM", "CMPCP" and "CMPCM" they are converted into Digital and output from PINs "OCA", "OCB" and "OCC". Those 3 output signals are input into TB9068FG again through PINs "ID", "IE" and "IF" for further processing by the commutation LOGIC. All of Comparator outputs are at CMOS level signal (5V) for easy interfacing with outside MCU.

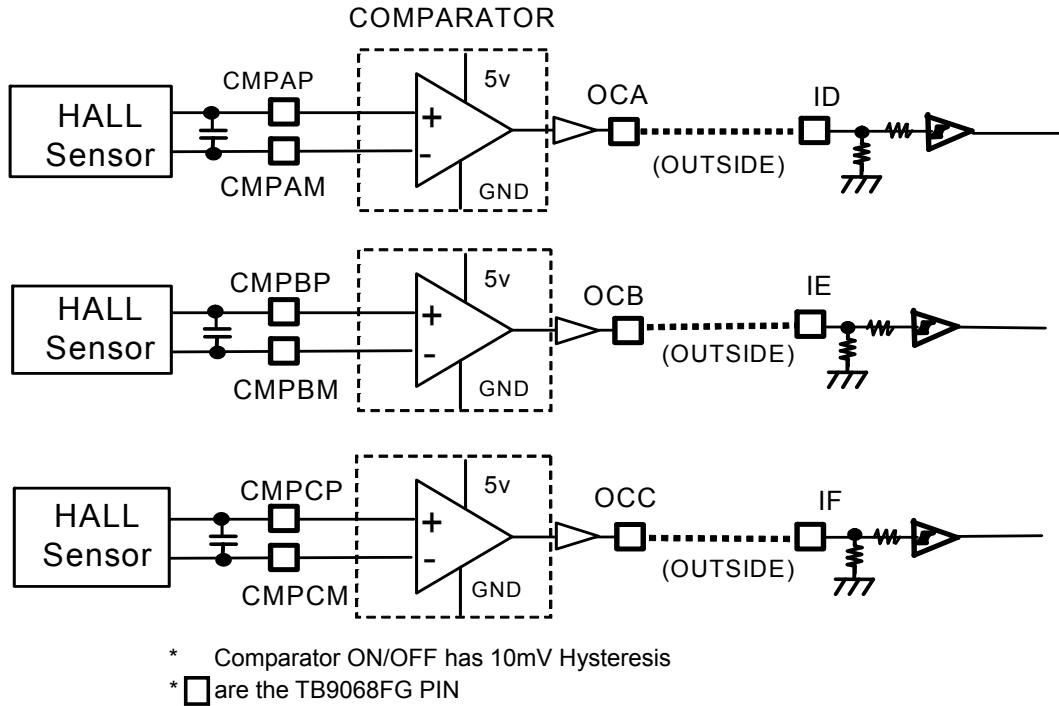

(ANALOG COMPARATOR TIMING CHART)

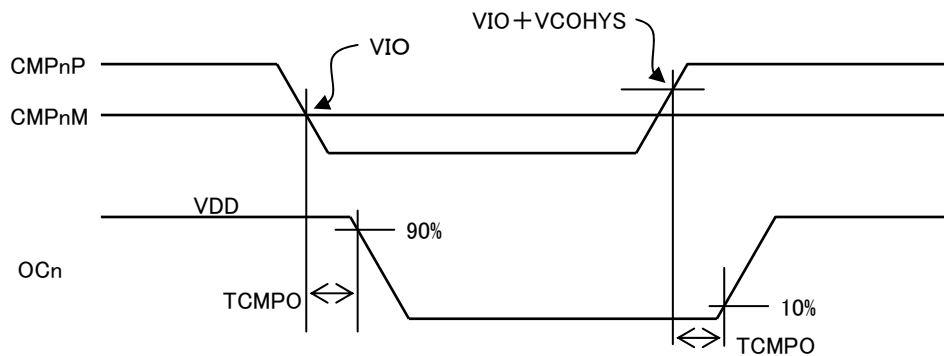

[CAUTION]

In case the integrated OP-AMPs are not used, the vacant input PINs should be connected as shown in right hand diagram. When setting up Pull Up resistors and CR filters at HALL-sensor outputs or PINs "OCA", "OCB" and "OCC" their values should be chosen in accordance with the internal Resistors (min. 62.5kΩ) as Resistor Divider.

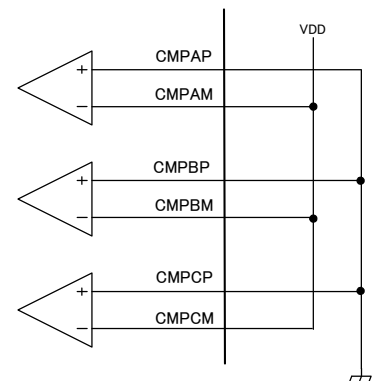

(7) INTEGRATED LIN TRANSCEIVER

(AC CHARACTERISTIC of LIN DRIVER)

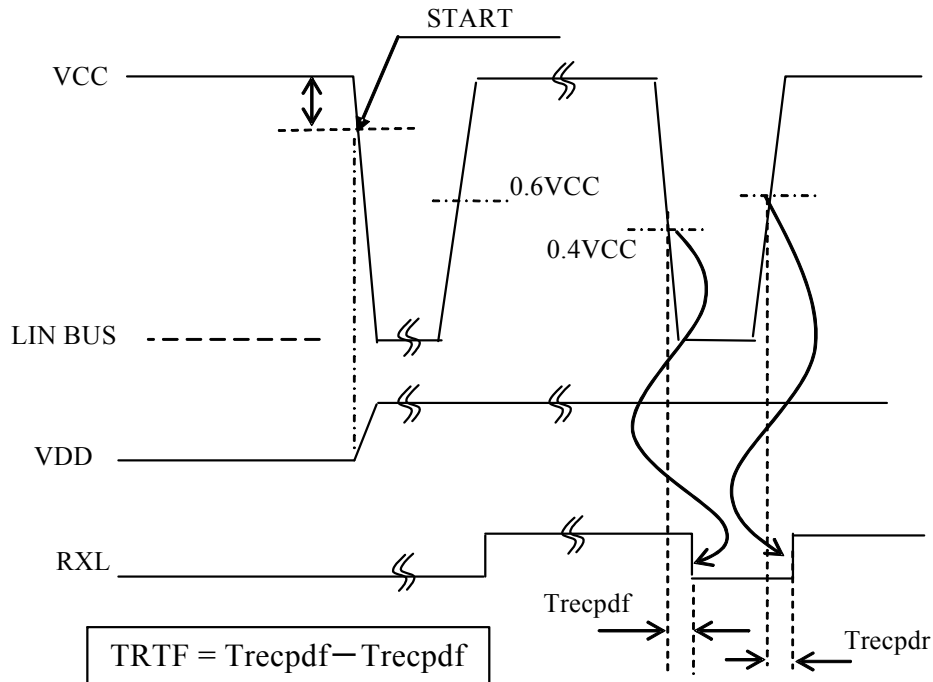

(AC CHARACTERISTICS CONDITION of LIN DRIVER)

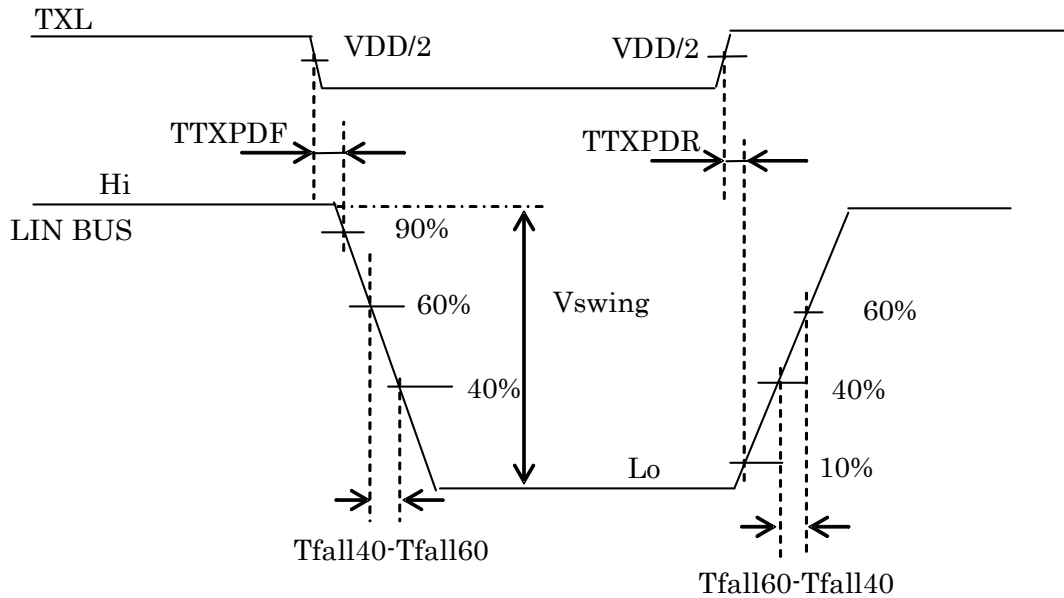

- $VTF/S = 0.2V_{swing} / (T_{fall40} - T_{fall60})$
- $VTR/S = 0.2V_{swing} / (T_{rise60} - T_{rise40})$

(AC CHARACTERISTICS CONDITION of LIN DRIVER) (cont.)

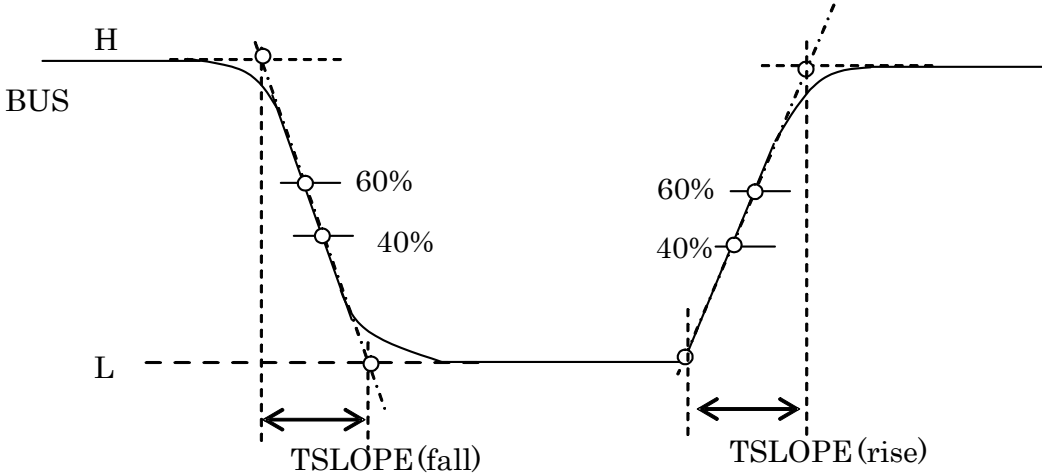

<ul style="list-style-type: none">· $TSLOPE(fall) = (T_{fall40} - T_{fall60}) / 0.2$· $TSLOPE(rise) = (T_{rise60} - T_{rise40}) / 0.2$

ABSOLUTE MAXIMUM RATINGS

CHARACTERISTIC	SYMBOL	PIN	CONDITION	VALUE	UNIT
Supply Voltage	VCC	VCC, VCC2	DC voltage	-0.3~+40	V
	VDD	VDD	DC voltage	-0.3~+6	
Protection DIODE Current	I _{diode}	BUS,I/O(except MOTOR drive output)	-	±10	mA
Output Current	IOUT	BUS	-	200	A
		OA,OB,OC	at Short Detection	±1.5	A
		RXL,NDG, OCA,OCB,OCC	-	±10	mA
		NRST	-	10	
Input/Output Current	VIN, VOUT	TP1,TP2,TP3 OA,OB,OC	-	-0.3~VCC+0.3	V
		CK, NRST, NDG, RXL, TXL, ENA, IA, IB, IC, ID, IE, IF, SEL, PWMI, WS, CMPAP, CMPAM, CMPBP, CMPBM, CMPCP, CMPCM, AMPP,AMPM, AMPO	-	-0.3~VDD+0.3	
		VREG	-	6.0	
		BUS	-	GND+30, VCC-30	
			VCC=GND=0V	±30	
Storage Temperature	T _{stg}		-	-55~+150	°C
Soldering Temperature	T _{sol}		Manual soldering	260 (10s)	
Maximum Power Dissipation	PD		PCB (50×50×1.6mm Cu36%) Ta=25°C	1.62	W

● LQFP48-P-0707-0.50 THERMAL RESISTANCE DATA (for reference only)

CHARACTERISTIC	Symbol	Value	Condition	Unit
Thermal Resistance	R _{θj-a}	266	IC	°C/W
	R _{θj-a}	77	PCBN (50×50×1.6mm Cu36%)	°C/W

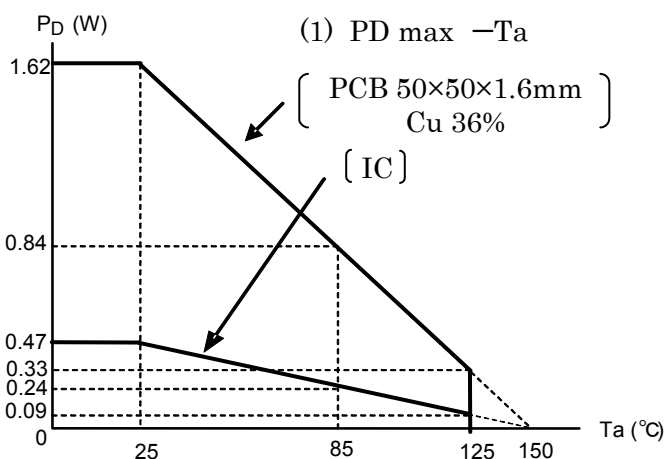

$$P_D = (150 - T_a) / R_{\theta j-a}$$

Max. Power Dissipation of IC (no PCB) at 25°C
 $(150 - 25) / 266 = 0.47 \text{ (W)}$

Max. Power Dissipation of IC on PCB
 (50×50×1.6mm Cu 36%) at 25°C
 $(150 - 25) / 77 = 1.62 \text{ (W)}$

[CAUTION] The absolute maximum ratings of a semiconductor device are a set of specified parameter values, which must not be exceeded during operation, even for an instant. If any of these rating would be exceeded during operation, the device electrical characteristics may be irreparably altered and the reliability and lifetime of the device can no longer be guaranteed. Moreover, these operations with exceeded ratings may cause break down, damage and/or degradation to any other equipment. Applications using the device should be designed such that each maximum rating will never be exceeded in any operating conditions. Before using, creating and/or producing designs, refer to and comply with the precautions and conditions set forth in these documents.

STATIC ELECTRICAL CHARACTERISTICS

Operating Range

CHARACTERISTIC	SYMBOL	VALUE	UNIT	NOTES
Supply Voltage	VCC	7~18	V	Supply Voltage for LOGIC
	VDD	4~5.5		
Operating Temperature	Topr	-40~125	°C	

IC Characteristics

The follows are under condition VCC=7~18V Ta =-40~125°C unless otherwise follows.

CHARACTERISTIC	SYMBOL	PIN	CONDITION	MIN.	TYP>.	MAX.	UNIT
Current Consumption (VCC)	ICC	VCC1,VCC2	VCC=14V	-	-	20	mA
Current Consumption(VDD)	IDD	VDD	VDD=5V	-	5	10	
Output Current "H" Level	IOH1	RXL, NDG OCA,OCB,OCC	VDD=5V VOH=4.5V	-	-5	-2	mA
Output Current "L" Level	IOL1	RXL, NDG, NRST OCA,OCB,OCC	VDD=5V VOL=0.5V	2	5	-	mA
Output Current of NRST "OFF"	ILO	NRST	VDD=5V,VOUT=0V	-1	-0.5	-0.2	mA
Input Current "L" Level	IIL1	TXL, CK	VDD=5V VIN=0V	-200	-100	-50	μA
	IIL2	ENA,WS, SEL,PWMI		-10	-	10	
	IIL3	IA,IB,IC,ID,IE,IF	VCC=12V, VIN=0V				
	IIL4	TP1,TP2,TP3					
Input Current "H" Level	IIH1	TXL, CK	VDD=5V VIN=5V	-10	-	10	μA
	IIH2	ENA,WS, SEL,PWMI		50	100	200	
	IIH3	IA,IB,IC,ID,IE,IF	20	40	80		
	IIH4	TP1,TP2,TP3	VCC=VIN=12V	-	240	480	
Input Voltage1 "L" Level	VIL1	TXL, CK SEL,PWMI, IA,IB,IC,ID,IE,IF		0	-	0.3VDD	V
Input Voltage1 "H" Level	VIH1			0.7VDD	-	VDD	
Hysteresis of Voltage1	VHYS1			-	0.4	-	

STATIC ELECTRICAL CHARACTERISTICS (cont.)

5V Regulator, RESET, Watch Dog Timer

The follows are under condition VCC=7~18V Ta =-40~125°C unless otherwise the follows.

CHARACTERISTICS	SYMBOL	PIN	CONDITION	MIN.	TYP.	MAX.	UNIT
Output Voltage of 5V Regulator	VREG	VREG1 VREG2	with Outside PNP Tr ILOAD 0mA~40mA	4.90	5.05	5.20	V
LINE Regulation	VLIN			-	0.1	0.5	%
LOAD Regulation	VLOAD			-	0.2	1.0	
BASE Current of PNP Tr.	IREGBASE			-	-	-1	mA
Current Limiter detection Voltage	VLIMIT	VS	with Outside Register	VCC-0.4	VCC-0.3	VCC-0.15	V
RESET OFF Voltage (Low VREG OFF)	VRSTH	VREG1 VREG2		0.90VREG	0.93VREG	0.97VREG	V
RESET ON Voltage (Low VREG Detection)	VRSTL			0.88VREG	0.91VREG	0.93VREG	
RESET Hysteresis Voltage (ON/OFF)	VRSTHY			-	0.15	-	V
Power On RESET Time	TPOR	NRST	see Page 6	12.5	25	50	ms
Watch Dog Timer Detection Time	TWD			25	50	100	
RESET Time	TRST			2.5	5	10	
"CK" Input Pulse Width	TCK	CK	thru NOISE Canceller	64	-	-	μs

Comparator

The follows are under condition VCC=7~18V Ta =-40~125°C unless otherwise the follows

CHARACTERISTICS	SYMBOL	PIN	CONDITION	MIN.	TYP.	MAX.	UNIT	
Input Voltage	VINH	CMPAP, CMPAM, CMPBP, CMPBM, CMPCP, CMPCM		VREG-2	VREG-1.5	-	V	
	VINL			-0.3	-	0	V	
Input Bias Current	IIBIAS			-2	-0.2	-	μA	
Input Offset Current	IIOFST			-	0.02	0.3		
Input Offset Voltage	VIO				-10	-	10	mV
COMP. Hysteresis *	VCOHYS			CMPAM=CMPBM =CMPCM=2.5V	2	9	15	mV
COMP. Output Delay	TCMPO		AC characteristics based	-	0.5	1.5	μs	

*) **COMP. Hysteresis (VCOHYS) is not tested directly. It is judged by the following (ref. (6) INTEGRATED ANALOG COMPARATOR for HALL SENSOR)**

$$(VCOHYS) = (VIO + VCOHYS) - (VIO)$$

STATIC ELECTRICAL CHARACTERISTICS (cont.)

MOTOR Driver

The follows are under condition VCC=7~18V Ta = -40~125°C unless otherwise the follows

CHARACTERISTICS	SYMBOL	PIN	CONDITION	MIN.	TYP.	MAX.	UNIT
Output Voltage	VOH1	OA, OB, OC	VCC:12V, Output "H" IOUT=-0.2A	VCC-0.4	11.8	VCC-0.1	V
	VOL1		VCC:12V, Output "L" IOUT=0.2A	0.1	0.2	0.4	
Pch Output Impedance1	RHON1		IOUT=-0.2A, Ta=25°C	0.7	0.85	1.3	Ω
			IOUT=-0.2A, Ta=125°C	0.7	-	2	
			IOUT=-0.2A, Ta=-40°C	0.5	-	1.3	
Nch Output Impedance1	RLON1		IOUT=0.2A, Ta=25°C	0.7	0.9	1.3	
			IOUT=0.2A, Ta=125°C	0.7	-	2	
			IOUT=0.2A, Ta=-40°C	0.5	-	1.3	
Output OFF Leak Current	ILO		Output OFF, VOUT=0V	-10	-	10	μA
			Output OFF, VOUT=VCC				
Driver ON Time	TONP			-	1.5	3.2	μs
Driver OFF Time	TOFFP			-	0.5	1.5	
Short Circuit Detection Current at GND-Short	IOVERL		Ta=25°C	-2.3	-1.5	-1.3	A
			Ta=125°C	-2.0	-	-1.2	
			Ta=-40°C	-2.5	-	-1.4	
Short Circuit Detection Current at VDD-Short	IOVERH	Ta=25°C	1.3	1.5	2.3		
		Ta=125°C	1.2	-	2.0		
		Ta=-40°C	1.4	-	2.5		
Over Voltage Detection(VCC1)	VSD	VCC1		24	27	30	V

STATIC ELECTRICAL CHARACTERISTICS (cont.)

LIN Receiver

The follows are under condition VCC=7~18V Ta =-40~125°C unless otherwise the follows

CHARACTERISTICS	SYMBOL	PIN	CONDITION	MIN.	TYP.	MAX.	UNIT
BUS Current	IHRX	BUS	VIN=VCC	-10	-	10	μA
	IILRX		VCC=12,VIN=0V	-600	-	-255	
	IBUSPAS REC		Driver OFF, VCC=7.3~18V, VBUS=8~18V, VBUS>VCC	-	-	20	
	IBUS		VCC=0V VBUS=0~18V	-	-	100	
	IBUS NOGND		at GND/VCC Short VBUS=8~18V, VCC=12V	-1	-	1	mA
Input Voltage	VIHRX			0.4VCC	0.5VCC	0.6VCC	V
	VILRX			0.4VCC	0.5VCC	0.6VCC	
Input Hysteresis	VHYS			-	-	0.175VCC	
DOMINANT Voltage Range	VDOM			-8	-	0.4VCC	
RECESSIVE Voltage Range	VREC			0.6VCC	-	18	
Output Delay Time Symmetry	TRTF		Trecpdf- Trecpdr AC Characteristics based	-2	-	2	

CAUTION: TB9068FG integrate 30kΩ(Typ.) Pull Up Register as LIN SLAVE.

LIN Driver

The follows are under condition VCC=7~18V Ta =-40~125°C unless otherwise the follows

CHARACTERISTICS	SYMBOL	PIN	CONDITION	MIN.	TYP.	MAX.	UNIT		
Output Current	IOLIN	BUS	TXL=0V , VOUT=VCCx0.4	40	100	200	mA		
Constant Slew Rate Transceiver	VTF/S		AC CONDITION	VCC=18V	1	1.6	3	V/μs	
	VTR/S			VCC=7.3	0.5	0.8	3		
Output Delay Time	TTXPDF					-	1	4	μs
	TTXPDR								
Constant Slope Time Transceiver	TSYS				VCC=18V	-5	-	5	
	TSLOPE				VCC=7.3V	-4	-	4	
Output Delay Time Symmetry	TRTF					3.5	-	22.5	
	TRXPD					-2	-	2	
Driver Dominant Voltage	VOLBUS				VCC=7.3V,LOAD=600Ω	-	-	1.2	V
					VCC=18V,LOAD=600Ω	-	-	2.0	
					VCC=7.3V,LOAD=1kΩ	0.6	-	-	
					VCC=18V,LOAD=1kΩ	0.8	-	-	
Output OFF Leak Current	ITXOFF1				VOUT=VCC *2	-	-	10	μA
	ITXOFF2				VCC=0V,VOUT=-12V	-1	-0.6	-	mA
Short Circuit detection Current	IOSHORT			*1	40	100	200	mA	

*1 SHORT DETECTION CIRCUIT does not provide the time to recover.

*2 The value of the LIN Receiver Input Current include the Output OFF Leak Current.

CIRCUIT DIAGRAM

MODE 0 (120deg. rotation, with HALL Sensor)

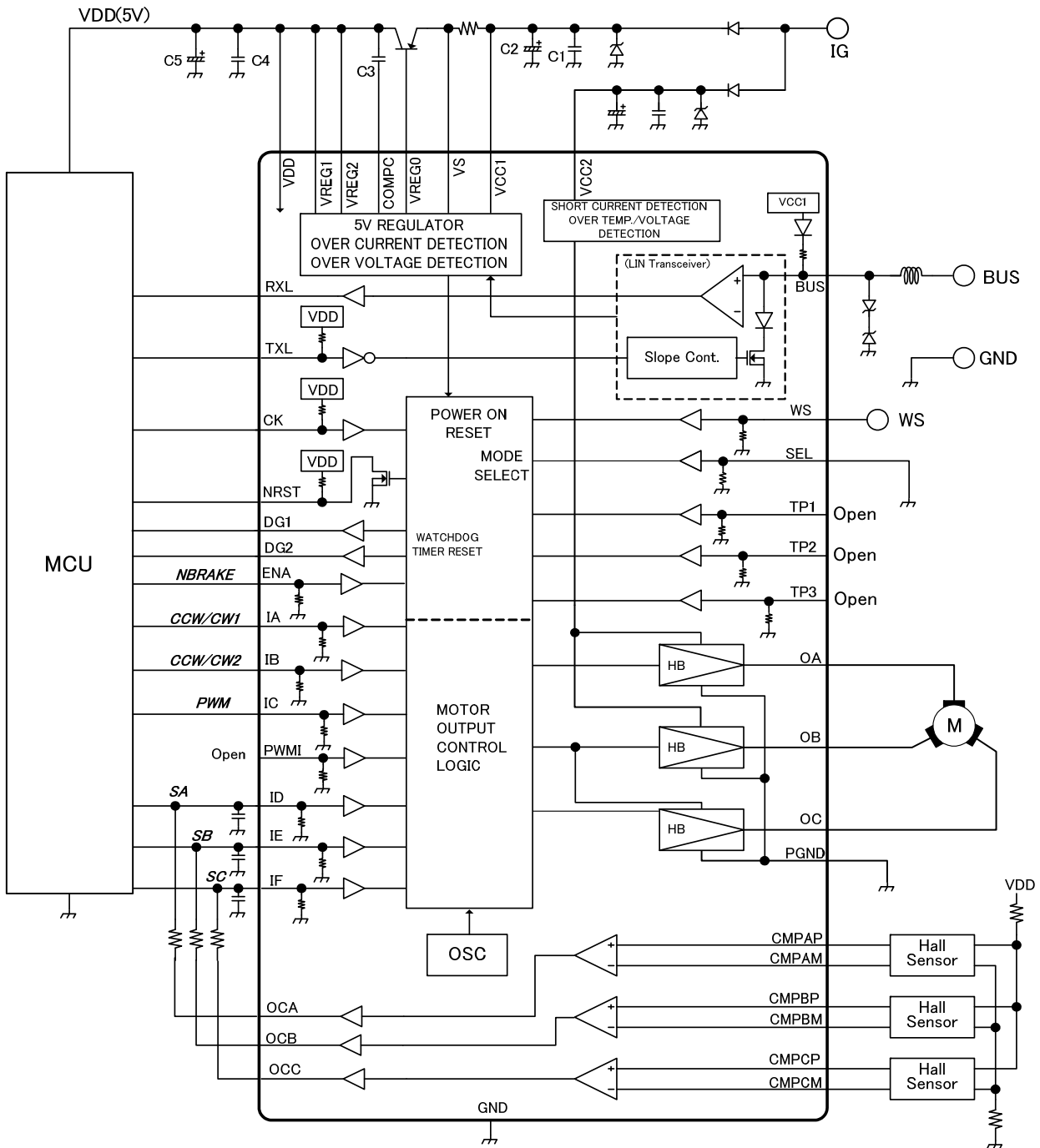

CAUTION.

- *1 C1, C2, C4, C5 is for NOISE reduction. It should be set near IC
- *2 C3 is for PHASE COMPENSATION. It should be set near IC.
- *3 Some of the functional blocks, circuit, or constants in the block diagram may be omitted or simplified for explanatory purpose.
- *4 Install the product correctly. Otherwise, it may result in break down, damage and/or deterioration to the product or equipment.
- *5 The application circuits shown in this document are provided for reference purposes only. Especially, a thorough evaluation is required on the phase of mass production design. Toshiba dose not grant the use of any industrial property rights with these examples of application circuits.

PACKAGE

LQFP48-P-0707-0.50

Unit: mm

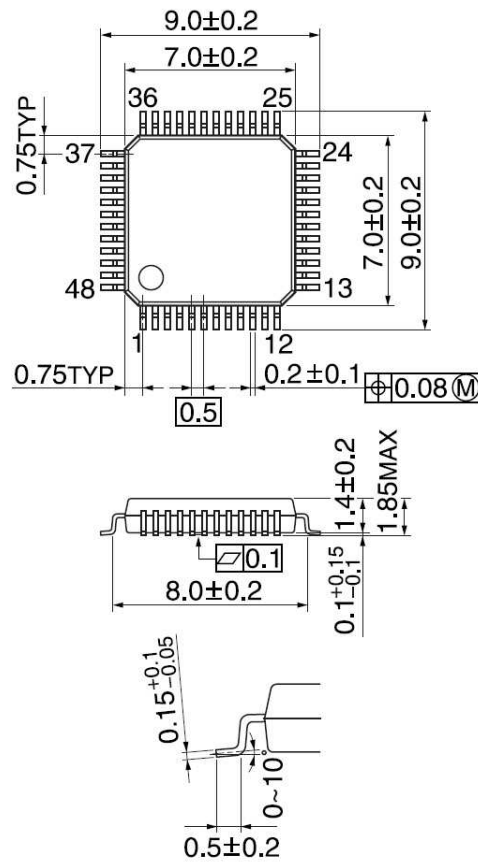

Weight: 0.189 g (Typ.)

About solder ability, it is checking on condition that following.

●Solder ability

(1)Use of Sn-37Pb solder Bath

- solder bath temperature= 230°C
- dipping time=5seconds
- the number of times =once
- use of R-type flux

(2)Use of Sn-3.0Ag-0.5Cu solder Bath

- solder bath temperature= 245°C
- dipping time=5seconds
- the number of times =once
- use of R-type flux

[CAUTION]

- Some of the functional blocks, circuits, or constants in the block diagram may be omitted or simplified for explanatory purpose.
- The equivalent circuit diagrams may be simplified or some parts of them may be omitted for explanatory purpose.
- Timing charts may be simplified for explanatory purpose.
- The absolute maximum ratings of a semiconductor device are a set of specified parameter values, which must not be exceeded during operation, even for an instant. If any of these ratings would be exceeded during operation, the device electrical characteristics may be irreparably altered and the reliability and lifetime of the device can no longer be guaranteed. Moreover, these operations with exceeded ratings may cause break down, damage and/or degradation to any other equipment. Applications using the device should be designed such that each maximum rating will never be exceeded in any operating conditions. Before using, creating and/or producing designs, refer to and comply with the precautions and conditions set forth in this documents.
- Ensure that the IC is mounted correctly. Failing to do so may result in the IC or target equipment being damaged.

RESTRICTIONS ON PRODUCT USE

- Toshiba Corporation, and its subsidiaries and affiliates (collectively "TOSHIBA"), reserve the right to make changes to the information in this document, and related hardware, software and systems (collectively "Product") without notice.
- This document and any information herein may not be reproduced without prior written permission from TOSHIBA. Even with TOSHIBA's written permission, reproduction is permissible only if reproduction is without alteration/omission.
- Though TOSHIBA works continually to improve Product's quality and reliability, Product can malfunction or fail. Customers are responsible for complying with safety standards and for providing adequate designs and safeguards for their hardware, software and systems which minimize risk and avoid situations in which a malfunction or failure of Product could cause loss of human life, bodily injury or damage to property, including data loss or corruption. Before customers use the Product, create designs including the Product, or incorporate the Product into their own applications, customers must also refer to and comply with (a) the latest versions of all relevant TOSHIBA information, including without limitation, this document, the specifications, the data sheets and application notes for Product and the precautions and conditions set forth in the "TOSHIBA Semiconductor Reliability Handbook" and (b) the instructions for the application with which the Product will be used with or for. Customers are solely responsible for all aspects of their own product design or applications, including but not limited to (a) determining the appropriateness of the use of this Product in such design or applications; (b) evaluating and determining the applicability of any information contained in this document, or in charts, diagrams, programs, algorithms, sample application circuits, or any other referenced documents; and (c) validating all operating parameters for such designs and applications. **TOSHIBA ASSUMES NO LIABILITY FOR CUSTOMERS' PRODUCT DESIGN OR APPLICATIONS.**
- Product is intended for use in general electronics applications (e.g., computers, personal equipment, office equipment, measuring equipment, industrial robots and home electronics appliances) or for specific applications as expressly stated in this document. Product is neither intended nor warranted for use in equipment or systems that require extraordinarily high levels of quality and/or reliability and/or a malfunction or failure of which may cause loss of human life, bodily injury, serious property damage or serious public impact ("Unintended Use"). Unintended Use includes, without limitation, equipment used in nuclear facilities, equipment used in the aerospace industry, medical equipment, equipment used for automobiles, trains, ships and other transportation, traffic signaling equipment, equipment used to control combustions or explosions, safety devices, elevators and escalators, devices related to electric power, and equipment used in finance-related fields. Do not use Product for Unintended Use unless specifically permitted in this document.
- Do not disassemble, analyze, reverse-engineer, alter, modify, translate or copy Product, whether in whole or in part.
- Product shall not be used for or incorporated into any products or systems whose manufacture, use, or sale is prohibited under any applicable laws or regulations.
- The information contained herein is presented only as guidance for Product use. No responsibility is assumed by TOSHIBA for any infringement of patents or any other intellectual property rights of third parties that may result from the use of Product. No license to any intellectual property right is granted by this document, whether express or implied, by estoppel or otherwise.
- **ABSENT A WRITTEN SIGNED AGREEMENT, EXCEPT AS PROVIDED IN THE RELEVANT TERMS AND CONDITIONS OF SALE FOR PRODUCT, AND TO THE MAXIMUM EXTENT ALLOWABLE BY LAW, TOSHIBA (1) ASSUMES NO LIABILITY WHATSOEVER, INCLUDING WITHOUT LIMITATION, INDIRECT, CONSEQUENTIAL, SPECIAL, OR INCIDENTAL DAMAGES OR LOSS, INCLUDING WITHOUT LIMITATION, LOSS OF PROFITS, LOSS OF OPPORTUNITIES, BUSINESS INTERRUPTION AND LOSS OF DATA, AND (2) DISCLAIMS ANY AND ALL EXPRESS OR IMPLIED WARRANTIES AND CONDITIONS RELATED TO SALE, USE OF PRODUCT, OR INFORMATION, INCLUDING WARRANTIES OR CONDITIONS OF MERCHANTABILITY, FITNESS FOR A PARTICULAR PURPOSE, ACCURACY OF INFORMATION, OR NONINFRINGEMENT.**
- Do not use or otherwise make available Product or related software or technology for any military purposes, including without limitation, for the design, development, use, stockpiling or manufacturing of nuclear, chemical, or biological weapons or missile technology products (mass destruction weapons). Product and related software and technology may be controlled under the Japanese Foreign Exchange and Foreign Trade Law and the U.S. Export Administration Regulations. Export and re-export of Product or related software or technology are strictly prohibited except in compliance with all applicable export laws and regulations.
- Please contact your TOSHIBA sales representative for details as to environmental matters such as the RoHS compatibility of Product. Please use Product in compliance with all applicable laws and regulations that regulate the inclusion or use of controlled substances, including without limitation, the EU RoHS Directive. TOSHIBA assumes no liability for damages or losses occurring as a result of noncompliance with applicable laws and regulations.