

TB9060FNG

3-Phase Full-Wave Sensorless Controller for Brushless DC Motors

The TB9060FNG is a 3-phase full-wave sensorless controller for brushless DC motors in automobiles. This product enables voltage to be controlled by PWM signal input. It can be used for a wide range of motors when combined with the appropriate drive circuits.

Features

- 3-phase full-wave sensorless drive
- PWM control (PWM signal is applied externally)
- Turn-on signal output current: 20 mA
- Overcurrent detection function
- Forward/reverse modes
- Lead-angle control function (0°, 7.5°, 15° and 30°)
- Lap turn-on function
- Two types of PWM output: upper PWM and upper/lower alternate PWM
- Rotational speed-sensing function
- Pb free

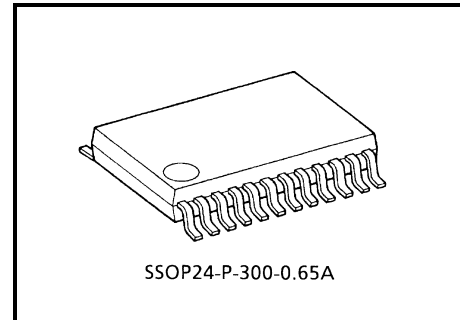

Weight: 0.13 g (typ.)

Regarding solderability, the following conditions have been confirmed:

- Solderability
 - (1) Use of Sn-63Pb solder bath
 - solder bath temperature = 230°C
 - dipping time = 5 seconds
 - the number of times = once
 - use of R-type flux
 - (2) Use of Sn-3.0Ag-0.5Cu solder bath
 - solder bath temperature = 245°C
 - dipping time = 5 seconds
 - the number of times = once
 - use of R-type flux

Block Diagram

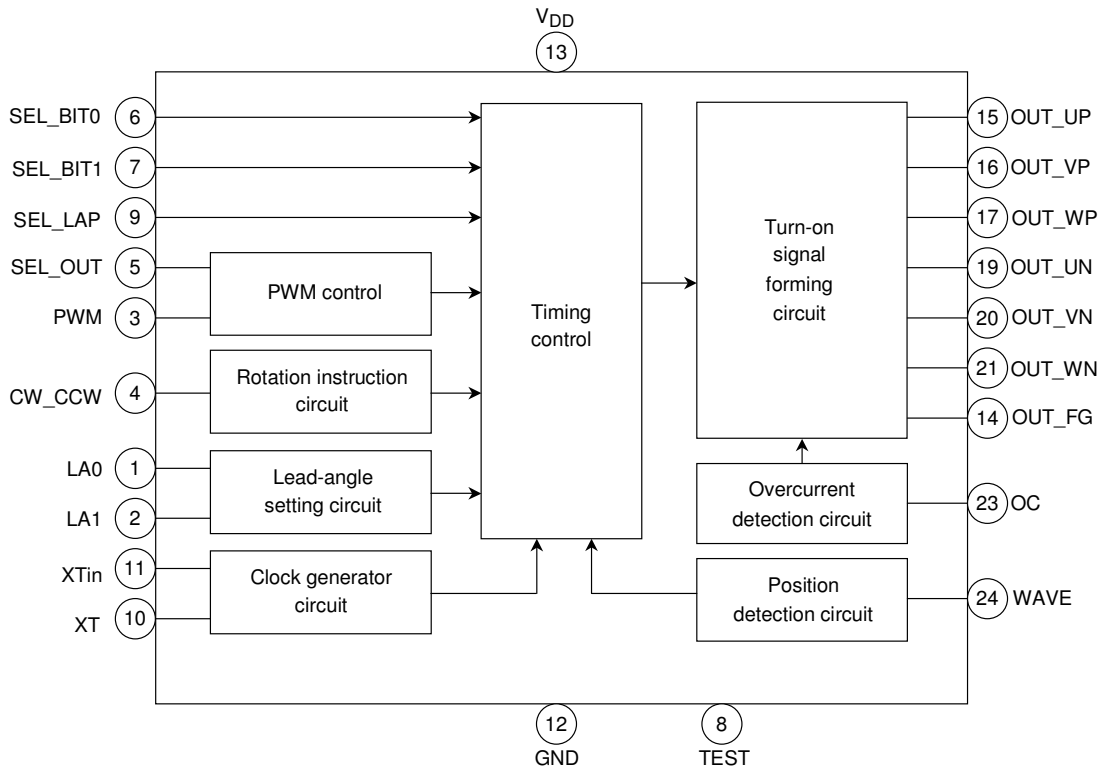

Note: Some functional blocks, circuits, or constants are omitted or simplified in the block diagram to clarify the descriptions of the relevant features.

Pin Assignment

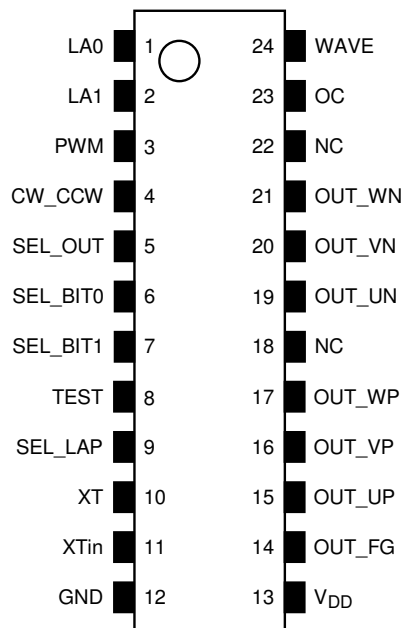

Pin Description

Pin No.	Symbol	I/O	Description
1	LA0	I	Lead-angle setting signal input pin · LA0 = Low, LA1 = Low: Lead angle 0° · LA0 = High, LA1 = Low: Lead angle 7.5° · LA0 = Low, LA1 = High: Lead angle 15° · LA0 = High, LA1 = High: Lead angle 30° · Built-in pull-down resistor (100 kΩ)
2	LA1	I	
3	PWM	I	PWM signal input pin · Applies active low PWM signal · Built-in pull-up resistor (100 kΩ) · Disables input of duty-100% (low) signal High for 250 ns or longer is required.
4	CW_CCW	I	Rotation direction signal input pin · High: Reverse (U → W → V) · Low, Open: Forward (U → V → W) · Built-in pull-down resistor (100 kΩ)
5	SEL_OUT	I	Pin to select the synthesis method for the turn-on signal and PWM signal · Low: Upper PWM · High: Upper/Lower alternate PWM · Built-in pull-down resistor (100 kΩ)
6	SEL_BIT0	I	Selection pin for the number of internal counter bits The forced-commutation frequency at the time of startup is determined by the resonator frequency and the number of counter bits. · SEL_BIT0 = High, SEL_BIT1 = High: 16 bits · SEL_BIT0 = Low, SEL_BIT1 = High: 14 bits · SEL_BIT0 = High, SEL_BIT1 = Low: 12 bits · SEL_BIT0: Built-in pull-down resistor (100 kΩ), SEL_BIT1: Built-in pull-up resistor (100 kΩ)
7	SEL_BIT1	I	
8	TEST	I	Test pin · Built-in pull down resistor (10 kΩ) Please connect this pin to GND in your application.
9	SEL_LAP	I	Lap turn-on select pin · Low: Lap turn-on · High: 120° turn-on · Built-in pull-up resistor (100 kΩ)
10	XT	—	Resonator connecting pin · Selects the startup commutation frequency. Startup commutation frequency $f_{st} = \text{Resonator frequency } f_{xt} / (6 \times 2^{(\text{BIT} + 3)})$ BIT: The number of counter bits determined by SEL_BIT0 and SEL_BIT1.
11	XTin	—	
12	GND	—	Connected to ground.

Pin No.	Symbol	I/O	Description
13	V _{DD}	—	Connected to 5-V power supply.
14	OUT_FG	O	Rotation signal output pin <ul style="list-style-type: none"> · Motor is stopped or starting: Low · Motor is in operation: The level is changed by the electrical frequency of the motor.
15	OUT_UP	O	U-phase upper turn-on signal output pin <ul style="list-style-type: none"> · U-phase winding wire positive ON/OFF switching pin · ON: Low, OFF: High
16	OUT_VP	O	V-phase upper turn-on signal output pin <ul style="list-style-type: none"> · V-phase winding wire positive ON/OFF switching pin · ON: Low, OFF: High
17	OUT_WP	O	W-phase upper turn-on signal output pin <ul style="list-style-type: none"> · W-phase winding wire positive ON/OFF switching pin · ON: Low, OFF: High
18	NC	—	Not connected
19	OUT_UN	O	U-phase lower turn-on signal output pin <ul style="list-style-type: none"> · U-phase winding wire negative ON/OFF switching pin · ON: High, OFF: Low
20	OUT_VN	O	V-phase lower turn-on signal output pin <ul style="list-style-type: none"> · V-phase winding wire negative ON/OFF switching pin · ON: High, OFF: Low
21	OUT_WN	O	W-phase lower turn-on signal output pin <ul style="list-style-type: none"> · W-phase winding wire negative ON/OFF switching pin · ON: High, OFF: Low
22	NC	—	Not connected
23	OC	I	Overcurrent signal input pin <ul style="list-style-type: none"> · High on this pin can put constraints on the turn-on signal that is performing PWM control. · Built-in pull-up resistor (100 kΩ)
24	WAVE	I	Position signal input pin <ul style="list-style-type: none"> · Applies the majority logic synthesis signals of the three-phase pin voltage. · Built-in pull-up resistor (100 kΩ)

Functional Description**1. Sensorless Drive**

On receipt of the PWM signal start instruction, the turn-on signal for forced commutation (commutation irrespective of the motor's rotor position) is applied to pins 15 to 17 and pins 19 to 21, and the motor starts to rotate. The rotation of the motor causes induced voltage on the winding wire pin for each phase.

When signals indicating positive or negative for pin voltage (including induced voltage) for each phase are applied to the respective position signal input pin, the turn-on signal for forced commutation is automatically switched to the turn-on signal for the position signal (induced voltage).

Thereafter, the turn-on signal is formed according to the induced voltage contained in the pin voltage so as to drive the brushless DC motor.

Sensorless drive timing charts (lead angles: 0°, 7.5°, 15° and 30°) are shown on the following pages.

Note: Timing charts may be simplified to clarify the descriptions of features and operations.

Figure 1. Sensorless drive timing chart (lead angle: 0°)

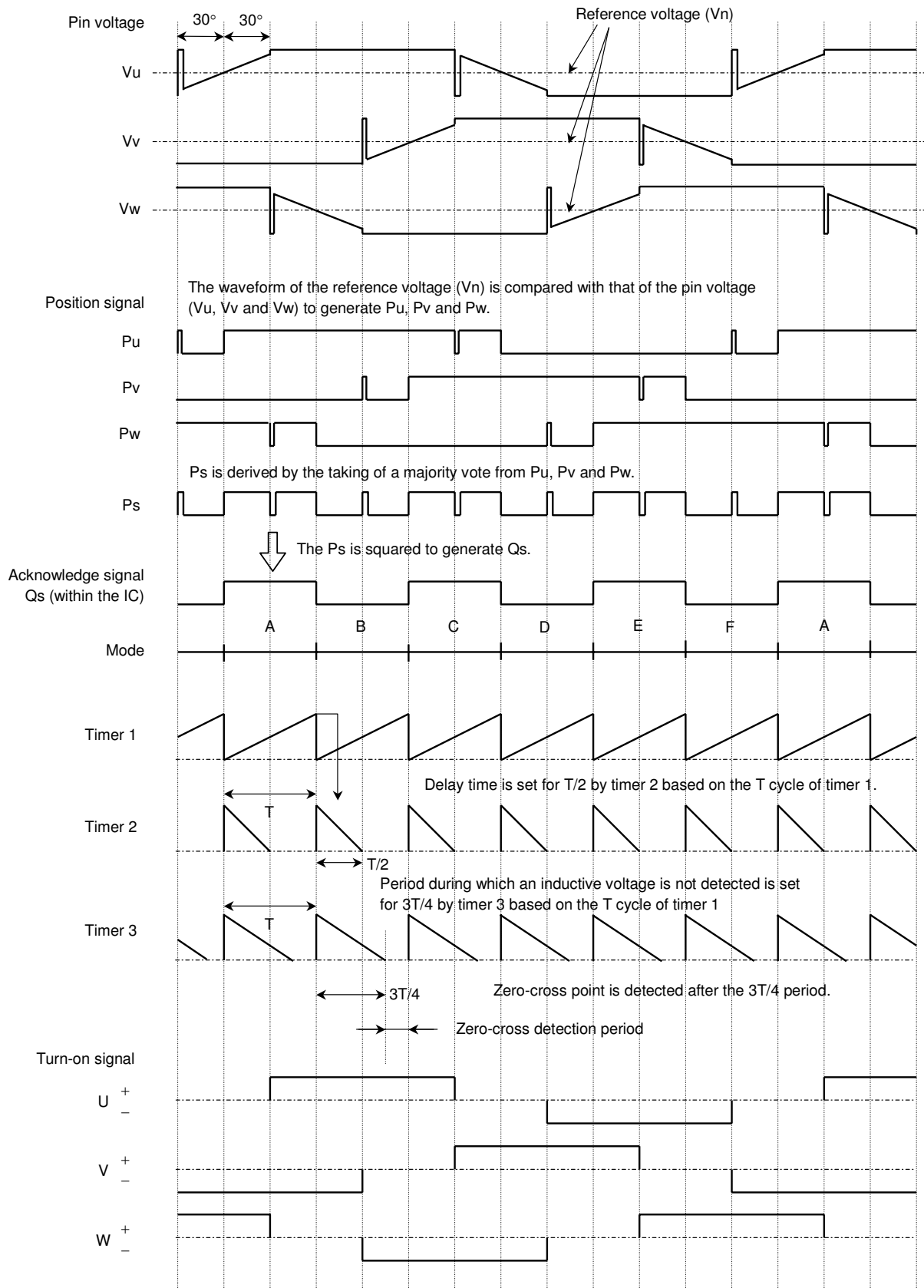

Figure 2. Sensorless drive timing chart (lead angle: 7.5°)

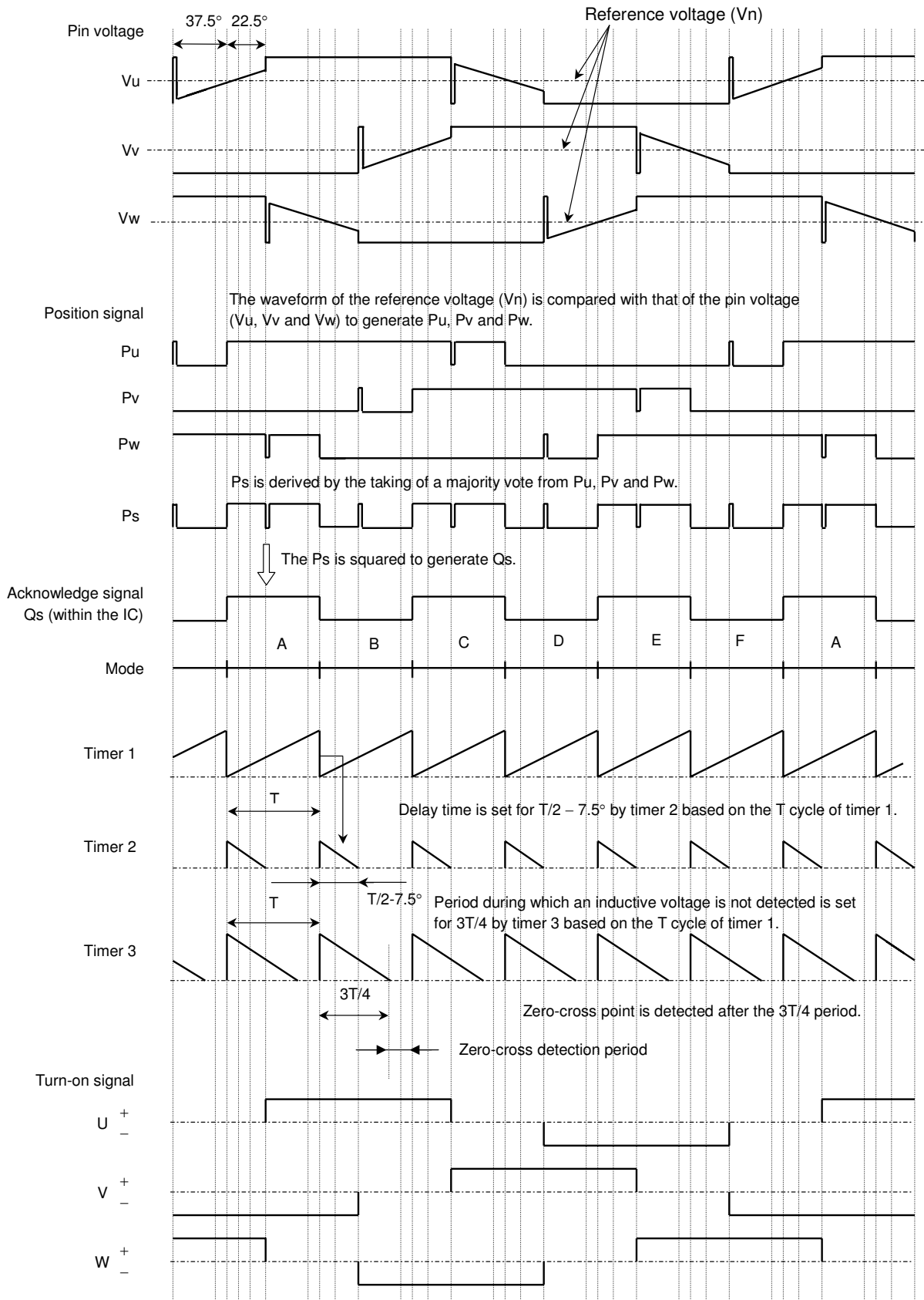

Figure 3. Sensorless drive timing chart (lead angle: 15°)

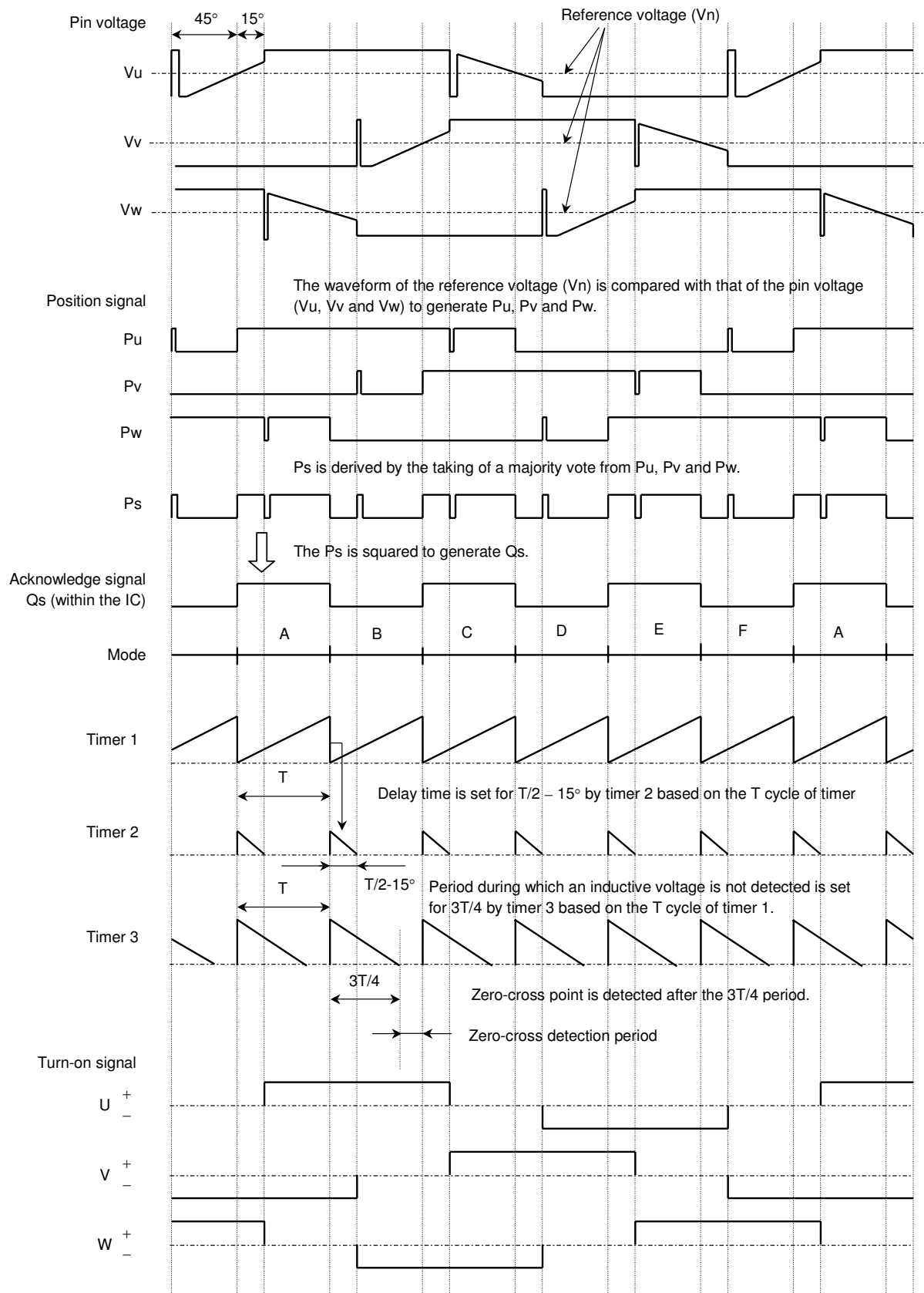
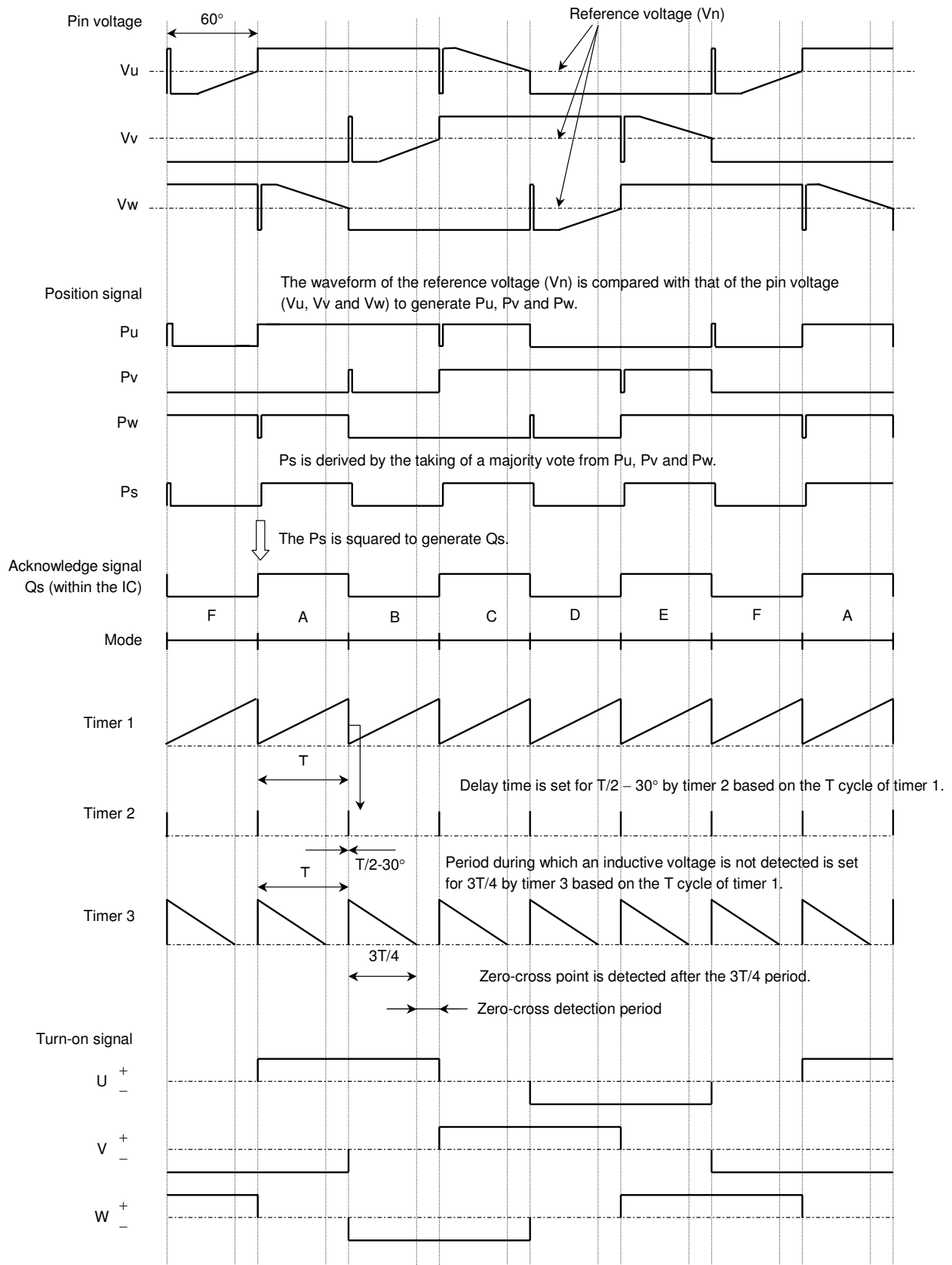

Figure 4 Sensorless drive timing chart (lead angle: 30°)



2. Startup commutation frequency (resonator pin and counter bit select pin)

The forced-commutation frequency at the time of startup is determined by the frequency of the resonator and the number of counter bits (within the IC).

SEL_BIT0 = High, SEL_BIT1 = High: Bit = 16

SEL_BIT0 = Low, SEL_BIT1 = High: Bit = 14

SEL_BIT0 = High, SEL_BIT1 = Low: Bit = 12

Startup commutation frequency $f_{st} = \text{Resonator frequency } f_{xt} / (6 \times 2^{(\text{BIT} + 3)})$

(BIT: The number of counter bits determined by SEL_BIT0 and SEL_BIT1.)

The forced-commutation frequency at the time of startup can be adjusted using the inertia of the motor and load.

- The forced-commutation frequency should be set higher as the number of magnetic poles increases.
- The forced-commutation frequency should be set lower as the inertia of the load increases.

2.1 Forced-commutation pattern

Forced commutation is performed at the timings shown below according to the state of CW_CCW. The commutation pattern immediately after the motor starts is always the same.

- (1) Forward rotation (CW_CCW = Low)

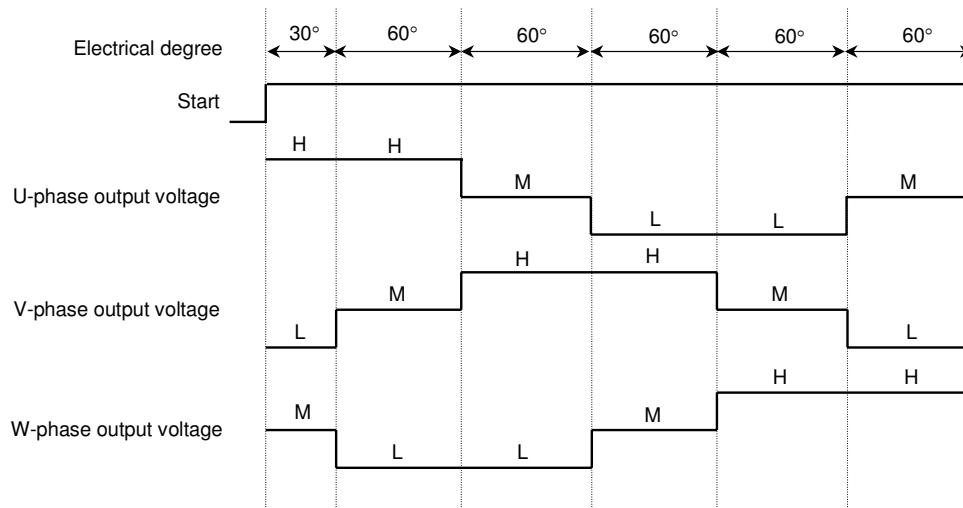

- (2) Reverse rotation (CW_CCW = High)

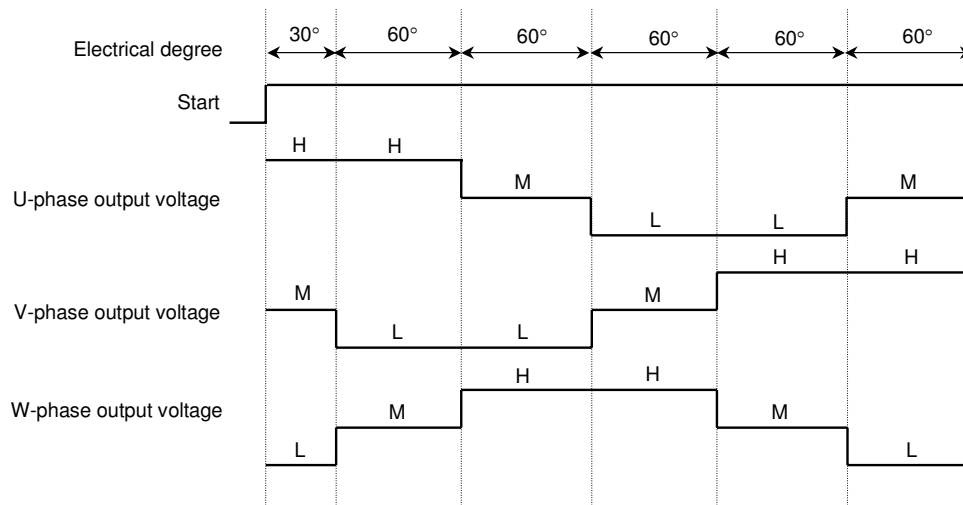

3. PWM Control

The PWM signal can be reflected in the turn-on signal by applying the PWM signal externally.

The frequency of the PWM signal should be set sufficiently high in relation to the electrical frequency of the motor and in accordance with the switching characteristics of the drive circuit.

Because positional detection is performed on the falling edges of the PWM signal, positional detection cannot be performed with 0% duty or 100% duty.

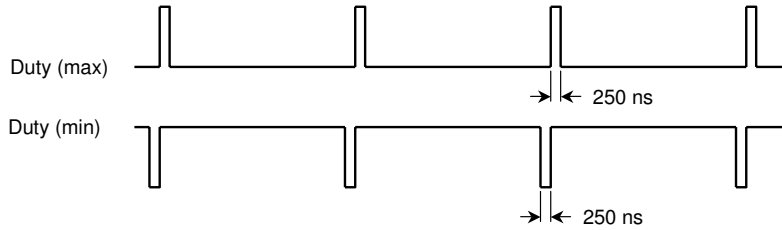

Even if the duty is 99%, the voltage applied to the motor is 100% duty owing to the storage time of the drive circuit.

4. Selecting PWM Output Form

The PWM output form can be selected using SEL_OUT.

SEL_OUT = Low

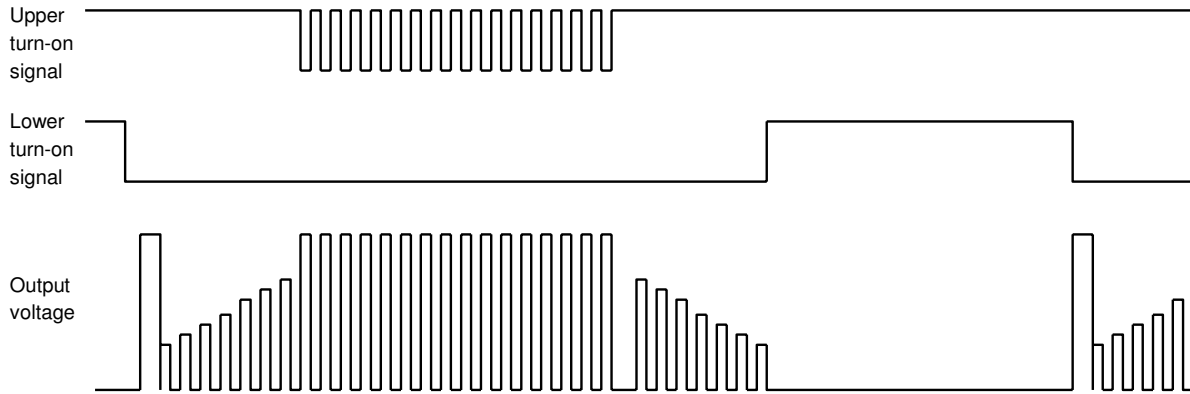

SEL_OUT = High

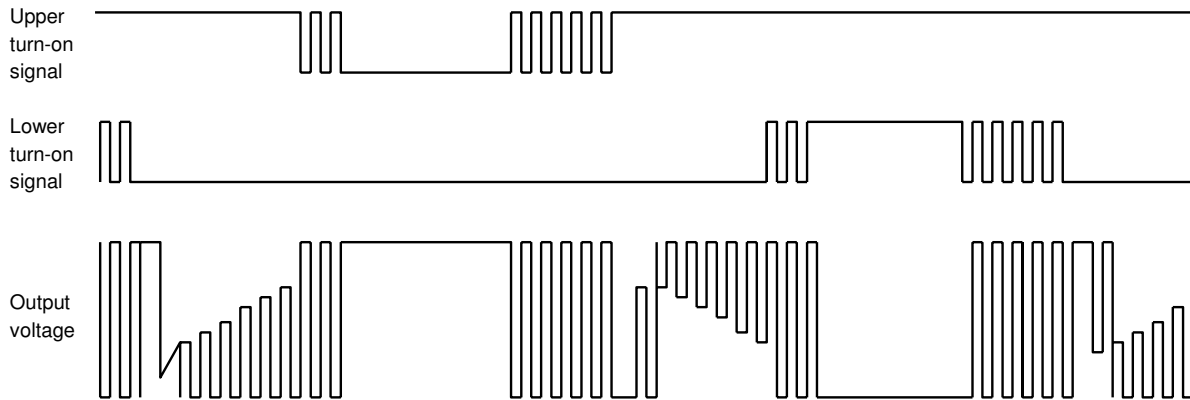

5. Positional Variation

Since positional detection is performed in synchronization with PWM signals, positional variation occurs in connection with the frequency of the PWM signal. For this reason, exercise special care when using the IC for high-speed motors.

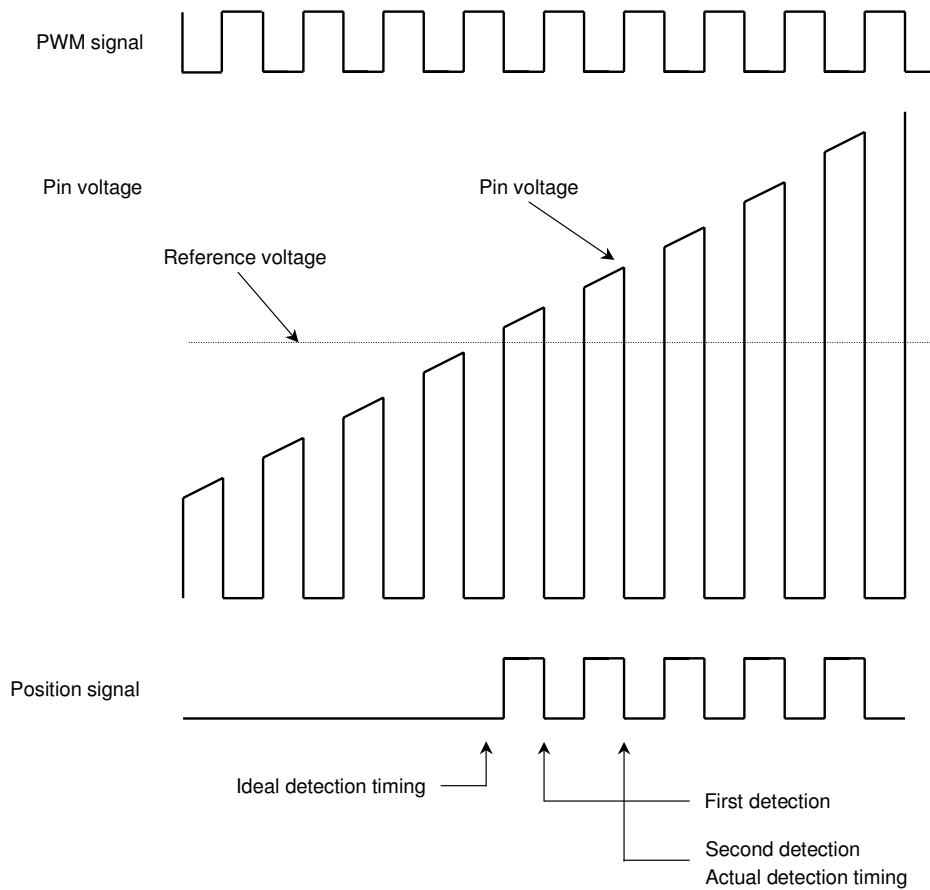

Variation is calculated by detecting at two consecutive rising edges of the PWM signal.
 $1/f_p < \text{Detection time variation} < 2/f_p$ f_p : PWM frequency

6. Lead-Angle Control

The lead angle is 0° during the startup forced commutation and automatically changes to the lead angle set using LA0 and LA1 when normal commutation begins. However, if both LA0 and LA1 are set High, the lead angle is 30° both in startup forced commutation and in normal commutation.

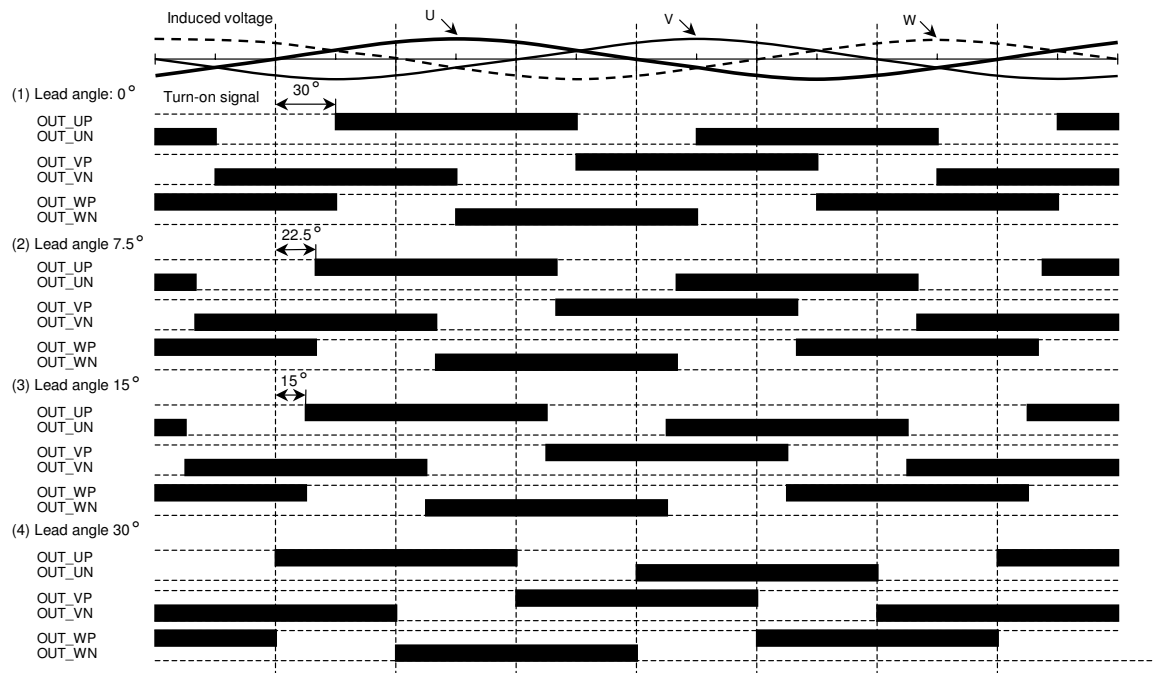

7. Lap Turn-on Control

When SEL_LAP = High, the turn-on degree is 120°. When SEL_LAP = Low, Lap Turn-on Mode starts.

In Lap Turn-on Mode, the time between the zero-cross point and the 120° turn-on timing becomes longer (see the shaded area in the chart below) so as to create some overlap when switching turn-on signals. The lap time varies depending on the lead-angle setting.

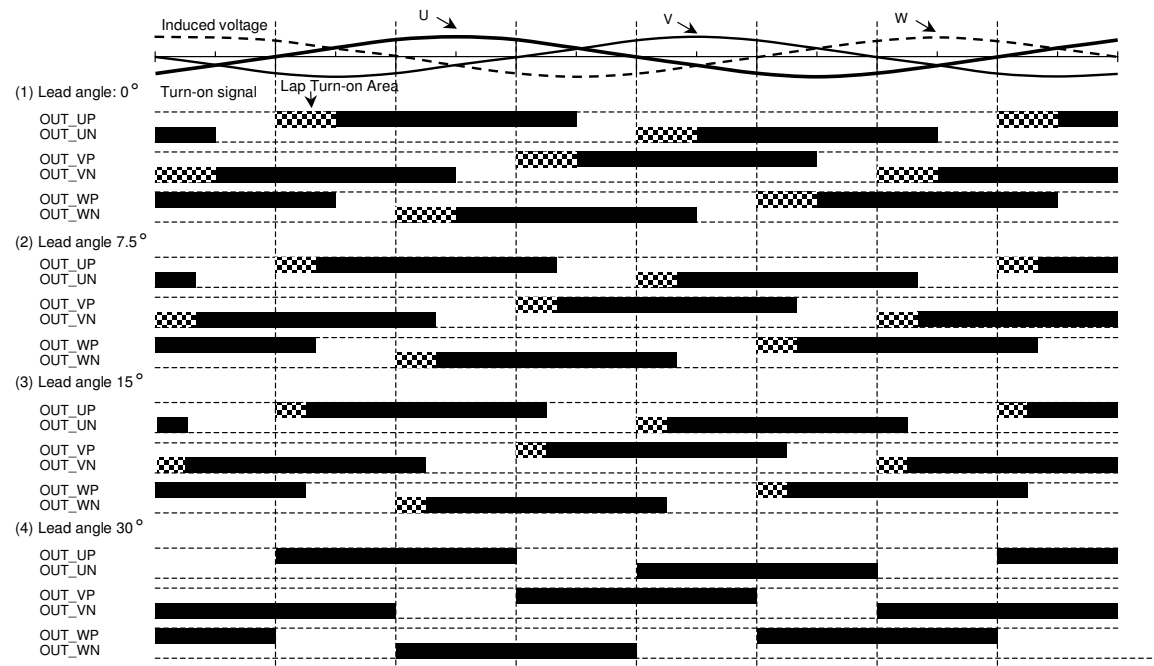

8. Start/Stop Control

Start/Stop is controlled using the PWM signal input pin.

A stop is acknowledged when the PWM signal duty is 0, and a start is acknowledged when an ON signal of a frequency two times the resonator frequency or more is applied successively.

Timing chart

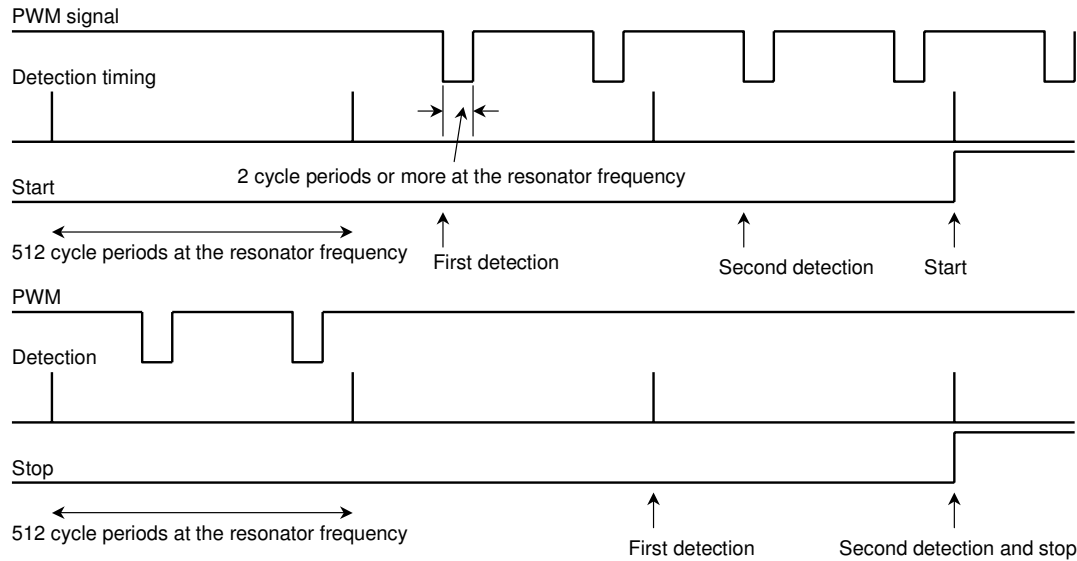

Note: Take sufficient care regarding noise on the PWM signal input pin.

9. Rotation-Signal Monitor Function

The rotation signal that senses rotational speed and indicates errors including motor lock is applied to the OUT_FG pin. Low voltage is applied to the pin at forced commutation for starting and stopping the motor. After normal commutation (position signal is detected) is performed for 480 electrical degrees, the rotation signal in synchronization with the U-phase position detection result is applied to the pin. If motor lock occurs due to overload during rotation, the forced commutation for starting the motor is performed and low voltage is applied to the pin.

It is possible to identify any error from the relation between the duty cycle of the PWM signal and the rotation frequency.

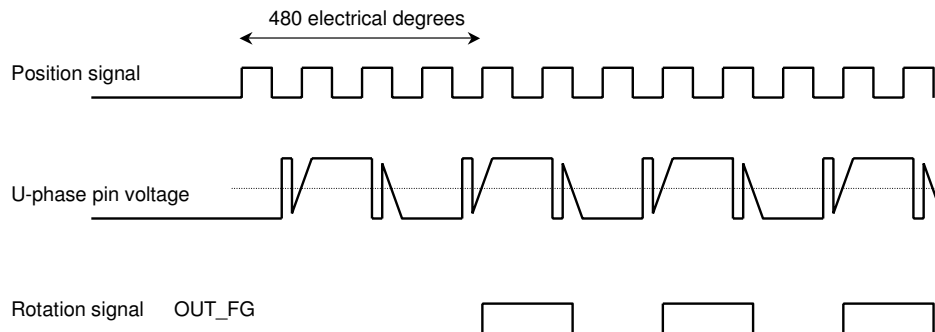

10. Pull-out of Synchronism

If the OUT_FG output is not received at the specified frequency during monitoring of the rotation signal (OUT_FG output), restart the TB9060FNG.

Maximum Ratings (Ta = 25 °C)

Characteristic	Symbol	Rating	Unit
Power supply voltage	V _{DD}	6.0	V
Input voltage	V _{IN}	-0.2~V _{DD}	V
Turn-on signal output current	I _{OUT}	20	mA
Power dissipation	P _D	850	mW
Operating temperature	T _{opr}	-40~125	°C
Storage temperature	T _{stg}	-55~150	°C

Note: The absolute maximum ratings of a semiconductor device are a set of specified parameter values that must not be exceeded during operation, even for an instant.

If any of these levels is exceeded during operation, the electrical characteristics of the device may be irreparably altered and the reliability and lifetime of the device can no longer be guaranteed, possibly causing damage to any other equipment with which it is used. Applications using the device should be designed so that the maximum ratings will never be exceeded in any operating conditions.

Ensuring that the parameter values remain within these specified ranges during device operation will help to ensure that the integrity of the device is not compromised.

Operating Conditions (Ta = -40~125 °C)

Characteristic	Symbol	Test Condition	Min	Typ.	Max	Unit
Power supply voltage	V _{DD}	—	4.5	5.0	5.5	V
Input voltage	V _{IN}	—	-0.2	—	V _{DD}	V
PWM frequency	f _{PWM}	—	—	16	—	kHz
Oscillation frequency	f _{osc}	—	1.0	—	10	MHz

Electrical Characteristics (V_{DD} = 5 V, Ta = -40 to 125°C)

Characteristic	Symbol	Test Circuit	Test Condition	Min	Typ.	Max	Unit
Static power supply current	I _{DD}	—	PWM = H, XTin = H	—	0.1	0.3	mA
Dynamic power supply current	I _{DD (opr)}	—	PWM = 50% Duty, XTin = 4 MHz	—	1	3	mA
Input current	I _{IN-1 (H)}	—	V _{IN} = 5 V, PWM, OC, WAVE SEL_LAP, SEL_BIT1	—	0	1	μA
	I _{IN-1 (L)}	—	V _{IN} = 0 V, PWM, OC, WAVE SEL_LAP, SEL_BIT1	-100	-50	—	
	I _{IN-2 (H)}	—	V _{IN} = 5 V, CW_CCW, LA0, LA1, SEL_OUT, SEL_BIT0	—	50	100	
	I _{IN-2 (L)}	—	V _{IN} = 0 V, CW_CCW, LA0, LA1, SEL_OUT, SEL_BIT0	-1	0	—	
Input voltage	V _{IN (H)}	—	PWM, OC, SEL_LAP CW_CCW, WAVE, LA0 LA1, SEL_OUT SEL_BIT0, SEL_BIT1	4.0	—	V _{DD}	V
	V _{IN (L)}	—		GND	—	1.0	
Input hysteresis voltage	V _H	—	—	—	0.6	—	V
Output voltage	V _{O-1 (H)}	—	I _{OH} = -1 mA OUT_UP, OUT_VP, OUT_WP	4.0	—	V _{DD}	V
	V _{O-1 (L)}	—	I _{OL} = 20 mA OUT_UP, OUT_VP, OUT_WP	GND	—	0.7	
	V _{O-2 (H)}	—	I _{OH} = -20 mA OUT_UN, OUT_VN, OUT_WN	3.8	—	V _{DD}	
	V _{O-2 (L)}	—	I _{OL} = 1 mA OUT_UN, OUT_VN, OUT_WN	GND	—	0.7	
	V _{O-3 (H)}	—	I _{OH} = -1 mA, OUT_FG	4.0	—	V _{DD}	V
	V _{O-3 (L)}	—	I _{OL} = 1 mA, OUT_FG	GND	—	0.7	
Output leak current	I _{L (H)}	—	V _{DD} = 5.5 V, V _{OUT} = 0 V OUT_UP, OUT_VP, OUT_WP OUT_UN, OUT_VN, OUT_WN OUT_FG	—	0	15	μA
	I _{L (L)}	—	V _{DD} = 5.5 V, V _{OUT} = 5.5 V OUT_UP, OUT_VP, OUT_WP OUT_UN, OUT_VN, OUT_WN OUT_FG	—	0	15	
Output delay time	t _{pLH}	—	PWM – Output	—	0.5	1	μS
	t _{pHL}	—		—	0.5	1	

Note: Output delay time test waveforms

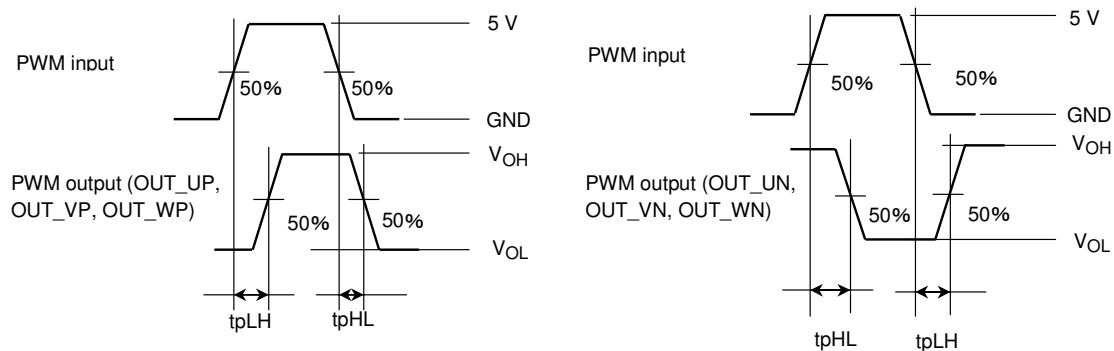

Example Application Circuit

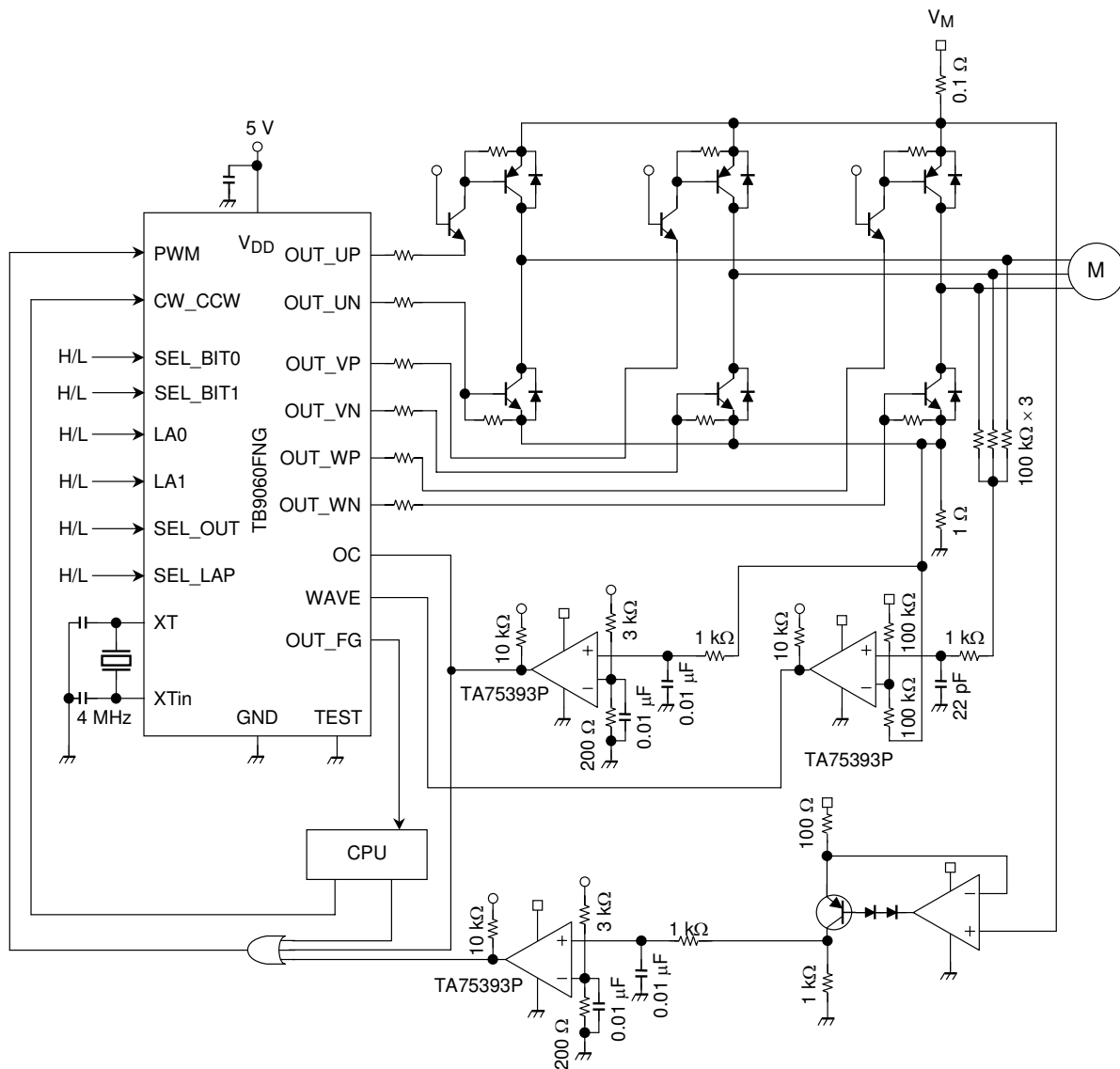

Note 1: Exercise due care in designing output V_{DD} lines and ground lines to avoid short circuits between outputs, V_{DD} faults or ground faults, which may cause the IC to break down.

Note 2: The above application circuit and constants mentioned are examples intended for reference purposes only. Since these constants may vary depending on the motor to be used, the appropriate values should be determined through experiment before use of the device.

Note 3: The TEST pin is for use only in factory testing and should be connected to the ground in any application circuit.

Note 4: Ensure that the IC is mounted correctly. Incorrect installation may damage the IC or target equipment.

Note 5: The application circuit shown above is not intended to guarantee mass production. Any application circuit for mass production requires thorough evaluation at the design stage.

Package Dimensions

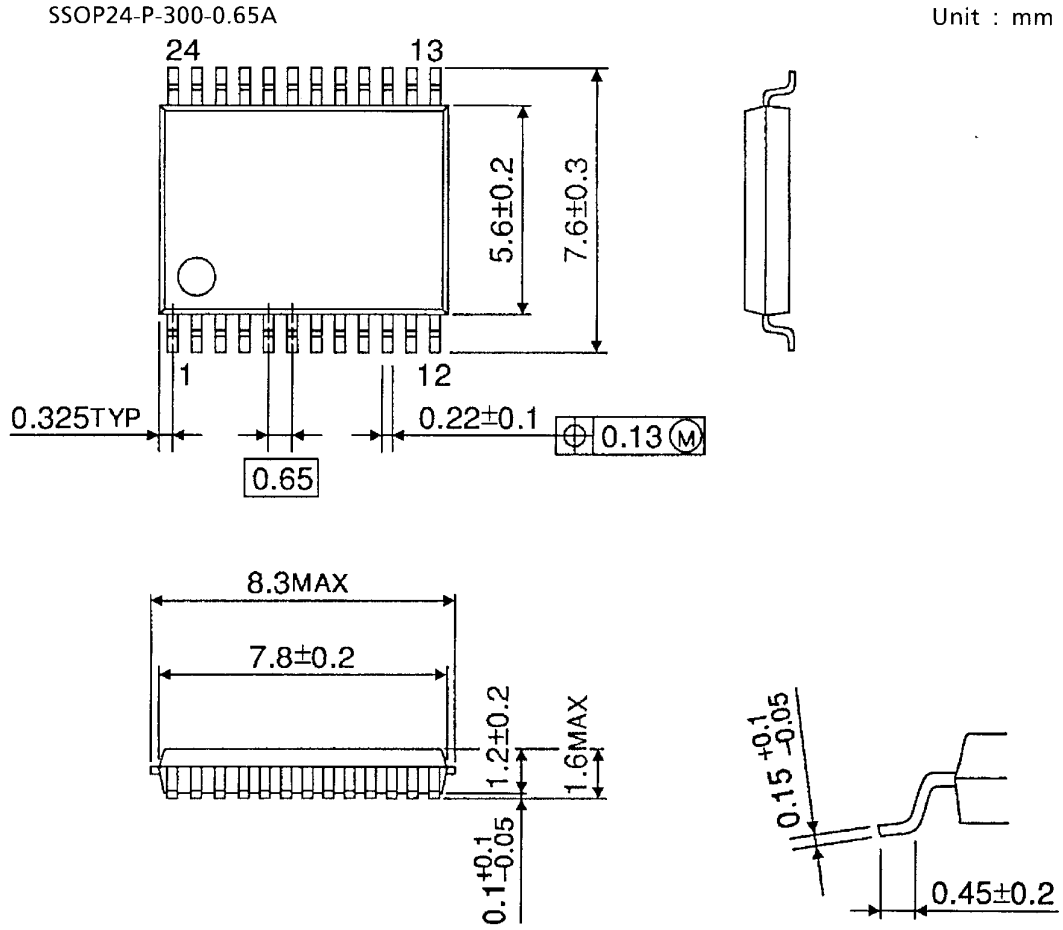

Weight: 0.13 g (typ.)

RESTRICTIONS ON PRODUCT USE

030619EBA

- The information contained herein is subject to change without notice.
- The information contained herein is presented only as a guide for the applications of our products. No responsibility is assumed by TOSHIBA for any infringements of patents or other rights of the third parties which may result from its use. No license is granted by implication or otherwise under any patent or patent rights of TOSHIBA or others.
- TOSHIBA is continually working to improve the quality and reliability of its products. Nevertheless, semiconductor devices in general can malfunction or fail due to their inherent electrical sensitivity and vulnerability to physical stress. It is the responsibility of the buyer, when utilizing TOSHIBA products, to comply with the standards of safety in making a safe design for the entire system, and to avoid situations in which a malfunction or failure of such TOSHIBA products could cause loss of human life, bodily injury or damage to property.
In developing your designs, please ensure that TOSHIBA products are used within specified operating ranges as set forth in the most recent TOSHIBA products specifications. Also, please keep in mind the precautions and conditions set forth in the "Handling Guide for Semiconductor Devices," or "TOSHIBA Semiconductor Reliability Handbook" etc..
- The TOSHIBA products listed in this document are intended for usage in general electronics applications (computer, personal equipment, office equipment, measuring equipment, industrial robotics, domestic appliances, etc.). These TOSHIBA products are neither intended nor warranted for usage in equipment that requires extraordinarily high quality and/or reliability or a malfunction or failure of which may cause loss of human life or bodily injury ("Unintended Usage"). Unintended Usage include atomic energy control instruments, airplane or spaceship instruments, transportation instruments, traffic signal instruments, combustion control instruments, medical instruments, all types of safety devices, etc.. Unintended Usage of TOSHIBA products listed in this document shall be made at the customer's own risk.
- The products described in this document are subject to the foreign exchange and foreign trade laws.
- TOSHIBA products should not be embedded to the downstream products which are prohibited to be produced and sold, under any law and regulations.