

TOSHIBA BiCMOS Integrated Circuit Silicon Monolithic

# TB9004FNG

## 5 V and 3.3/2.5/1.5 V Dual-Voltage Regulator with Watchdog Timer

The TB9004FNG is a system regulator IC for automotive applications, specially designed for 3.3/2.5/1.5V microcomputer systems. It incorporates two constant-voltage power outputs and various system reset functions.

One of the power outputs, VCC1, supplies 3.4, 2.5, or 1.5 V, as selected according to the application. This output uses an external output transistor. Any desired current limiter value can be set using an external adjusting resistor.

The other power output, VCC2, supplies 5.0 V and also uses an external output transistor. Any desired current limiter value can be set using an external adjusting resistor.

For a system reset, both power outputs have a low-voltage monitor, power-on reset, and watchdog timer.

With the both power outputs turned off, the TB9004FNG consumes 0  $\mu$ A.

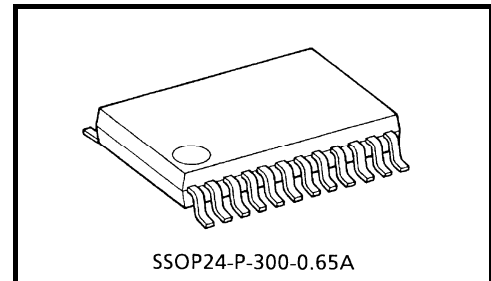

SSOP24-P-300-0.65A  
Weight: 0.14 g (typ.)

### Features

- Power output VCC1
  - Output voltage: 3.4 V  $\pm$  0.10 V/2.55 V  $\pm$  0.10 V/1.55 V  $\pm$  0.07 V (selectable)
  - Output current: 600 mA (with external transistor)
  - Current limiter: Variable using external adjusting resistor
- Power output VCC2
  - Output voltage: 5.0 V  $\pm$  0.12 V
  - Output current: 600 mA (with external transistor)
  - Current limiter: Variable using external adjusting resistor
- Reset functions: Low-voltage monitor, power-on reset, and watchdog timer
- Low current consumption: Active (VCC1/VCC2 = ON): 300  $\mu$ A (typ.)  
Standby (VCC1 = ON, VCC2 = OFF): 150  $\mu$ A (typ.)  
Stop (VCC1/VCC2 = OFF): 0  $\mu$ A (typ.)
- W/D stop control: Control start/stop of watchdog timer
- Operating temperature range: -40 to 125°C
- Small flat package: 24-pin SSOP (0.65-mm pitch)
- The product(s) is/are compatible with RoHS regulations (EU directive 2002 / 95 / EC) as indicated, if any, on the packaging label ("[[G]]/RoHS COMPATIBLE", "[[G]]/RoHS [[Chemical symbol(s) of controlled substance(s)]]", "RoHS COMPATIBLE" or "RoHS COMPATIBLE, [[Chemical symbol(s) of controlled substance(s)]]>MCV").

### About Solderability, following conditions were confirmed

- Solderability
  - (1) Use of Sn-37Pb solder Bath
    - solder bath temperature = 230°C
    - dipping time = 5 seconds
    - the number of times = once
    - use of R-type flux
  - (2) Use of Sn-3.0Ag-0.5Cu solder Bath
    - solder bath temperature = 245°C
    - dipping time = 5 seconds
    - the number of times = once
    - use of R-type flux

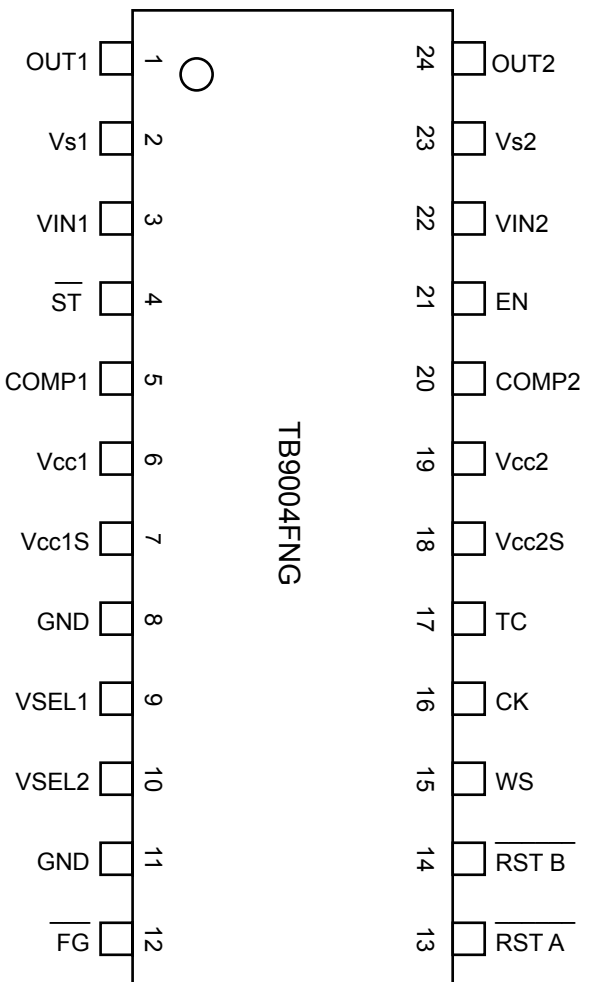

**Pin Layout**

## Pin Description

Pin No.	Symbol	Description
1	OUT1	External transistor control pin. Connect the base of the external PNP transistor to this pin.
2	VS1	Detection pin for the V <sub>CC1</sub> current limiter. A voltage drop occurring in the external resistor Rs1 between VIN1 and VS1 is monitored. The current limiter is actuated when the voltage drop exceeds 0.3 V.
3	VIN1	Power supply input pin for V <sub>CC1</sub> .
4	$\overline{ST}$	Enable pin for ON/OFF control of the V <sub>CC1</sub> /V <sub>CC2</sub> constant-voltage power outputs. Driving ST high turns the outputs on while driving it low turns them off. When both outputs are turned off, the TB9004FNG consumes a current of 0 $\mu$ A (typ.). It contains a 250 k $\Omega$ pull-down resistor.
5	COMP1	Phase compensating pin for V <sub>CC1</sub> . Connect a phase compensating capacitor between V <sub>CC1</sub> and this pin.
6	V <sub>CC1</sub>	Voltage detection output pin for V <sub>CC1</sub> . Connect the collector of the external PNP transistor to this pin. This pin provides a 3.3, 2.5, or 1.5 V constant-voltage feedback.
7	V <sub>CC1S</sub>	Pin for detecting whether the V <sub>CC1</sub> pin is open. If there is a voltage difference between V <sub>CC1</sub> and V <sub>CC1S</sub> , the TB9004FNG lowers the V <sub>CC1</sub> output voltage.
8	GND	Ground pin
9	V <sub>SEL1</sub>	Pin for selecting the V <sub>CC1</sub> output voltage from among 3.3, 2.5, and 1.5 V. The voltage is selected using a combination of V <sub>SEL1</sub> and V <sub>SEL2</sub> . This pin incorporates a pull-down resistor.
10	V <sub>SEL2</sub>	
11	GND	Ground pin
12	$\overline{FG}$	Flag output when V <sub>CC1</sub> or V <sub>CC2</sub> is detected to be open. The pin is usually high but driven low when either pin is detected to be open. N-ch MOS drain output with a 10 k $\Omega$ pull-up resistor connected to V <sub>CC2</sub> .
13	$\overline{RST A}$	V <sub>CC1</sub> /V <sub>CC2</sub> low-voltage monitor output and power-on reset/watchdog timer reset output pin <ul style="list-style-type: none"> <li>· Generates a reset signal when a low voltage is detected for V<sub>CC1</sub> or V<sub>CC2</sub>.</li> <li>· Generates a reset signal which is determined by the capacitor CT connected to the TC pin.</li> <li>· Intermittently generates reset pulses if no clock is supplied to the CK pin.</li> </ul> N-ch MOS drain output with a 10 k $\Omega$ pull-up resistor connected to V <sub>CC2</sub> .
14	$\overline{RST B}$	Low-voltage monitor output pin for V <sub>CC1</sub> and V <sub>CC2</sub> . Generates a reset signal when a low voltage is detected for V <sub>CC1</sub> or V <sub>CC2</sub> . Linked with a power-on reset but not linked with the watchdog timer.
15	WS	Enable pin for ON/OFF control of the watchdog timer. Driving WS low turns the timer on while driving it high turns the timer off. Use this pin when the watchdog timer is not necessary or to stop it temporarily. It contains a 250 k $\Omega$ pull-down resistor to GND.
16	CK	Clock input pin for the watchdog timer. It contains a 250 k $\Omega$ pull-down resistor connected to GND.
17	TC	Pin for setting a time for the power-on reset timer and watchdog timer when V <sub>CC1</sub> and V <sub>CC2</sub> rise. It connects to a capacitor CT which is grounded. It contains a 10 $\mu$ A pull-up constant current.
18	V <sub>CC2S</sub>	Pin for detecting whether the V <sub>CC2</sub> pin is open. If there is a voltage difference between V <sub>CC2</sub> and V <sub>CC2S</sub> , the TB9004FNG lowers the V <sub>CC2</sub> output voltage.
19	V <sub>CC2</sub>	Voltage detection pin for the 5 V constant-voltage power supply, V <sub>CC2</sub> . It also supplies power to the reset timer block.
20	COMP2	Phase compensating pin for V <sub>CC2</sub> . Connect a phase compensating capacitor between V <sub>CC2</sub> and this pin.
21	EN	Enable pin for ON/OFF control of the V <sub>CC2</sub> constant-voltage power output. Driving EN high turns the 5 V output on while driving it low turns the output off. It contains a 250 k $\Omega$ pull-down resistor.
22	VIN2	Power supply input pin.
23	VS2	Detection pin for the V <sub>CC2</sub> current limiter. A voltage drop occurring in the external resistor Rs2 between VIN2 and VS2 is monitored. The current limiter is actuated when the voltage drop exceeds 0.3 V.
24	OUT2	External transistor control pin. Connect the base of the external PNP transistor to this pin.

**Internal Circuits of Input/Output Pins**

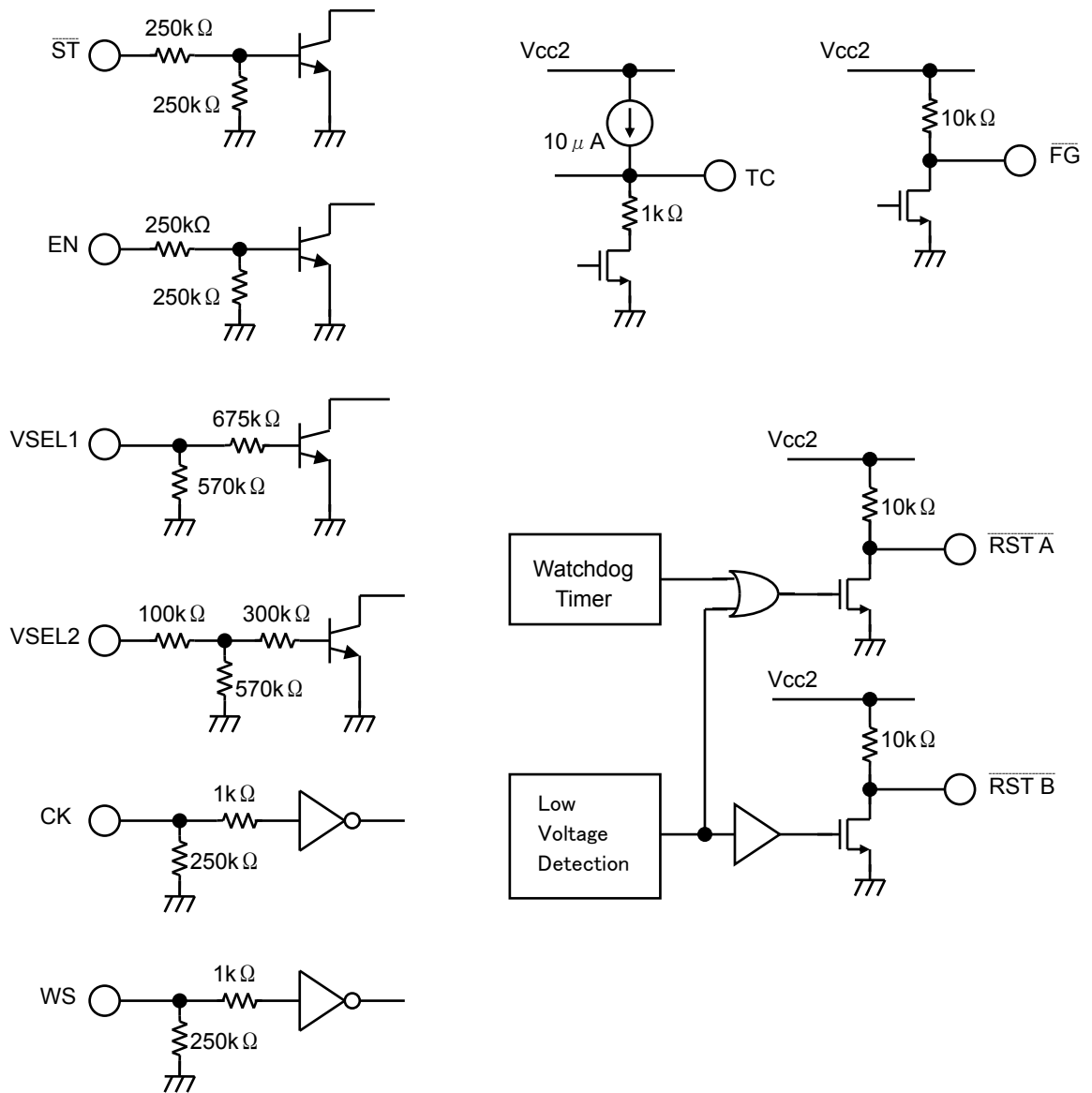

Note: The internal circuit diagrams are intended as an aid for describing circuits; they may be shown in abbreviated or simplified format.

**Timing Charts**

**Timing (1)**

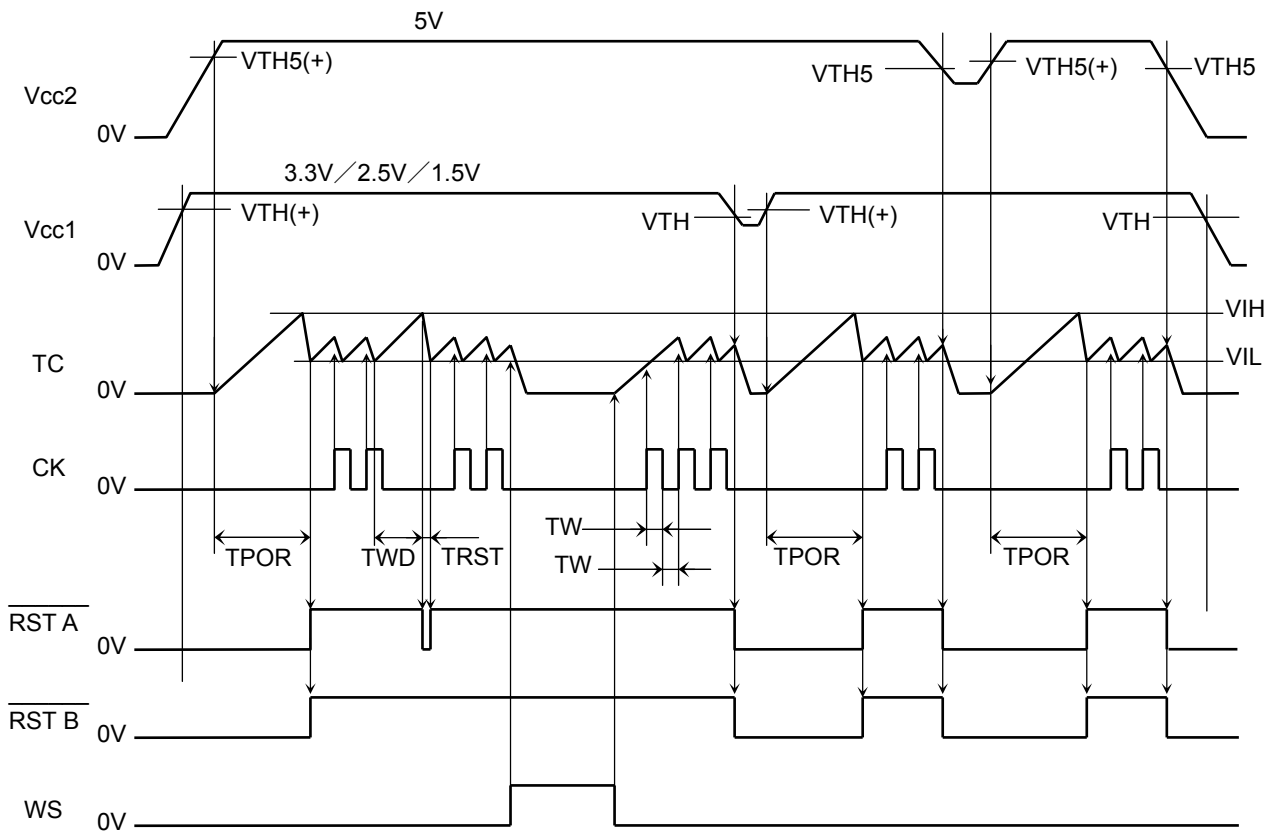

**Timing (2)**

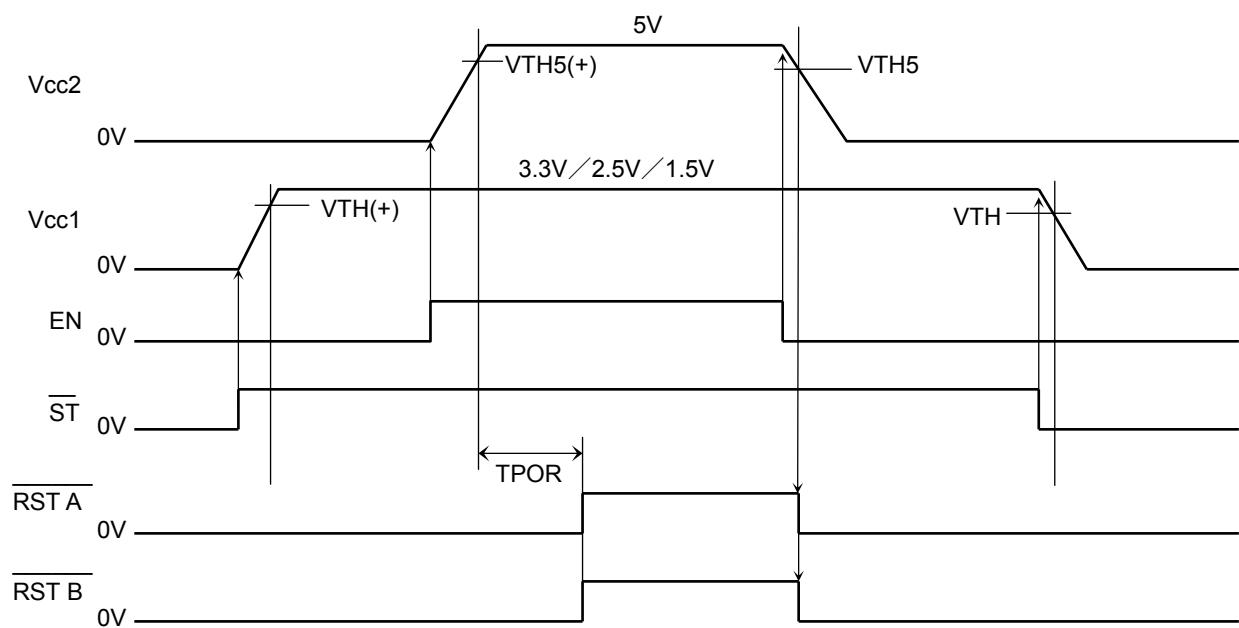

Note1: See Electrical Characteristics about symbols in timing charts.

Note2: Timing charts may be simplified to clarify the descriptions of features and operations.

## Absolute Maximum Ratings (Ta = 25°C)

Characteristics	Symbol	Pins	Rating	Unit
Input voltage	VIN-1	VIN1, VIN2	45 (1 s)	V
	VIN-2	EN, ST, VSEL1, VSEL2	VIN2	
	VIN-3	CK, TC, WS	Vcc2	
	VIN-4	VIN1, VIN2	40	
Output current	IOUT1	RST A , RST B	10	mA
	IOUT2	FG	10	
Operating temperature	T <sub>opr</sub>	–	–40 to 125	°C
Storage temperature	T <sub>stg</sub>	–	–55 to 150	°C

Note: The absolute maximum ratings of a semiconductor device are a set of specified parameter values that must not be exceeded during operation, even for an instant.

If any of these levels is exceeded during operation, the electrical characteristics may be irreparably altered and the reliability and lifetime of the device can no longer be guaranteed, possibly causing damage to any other equipment with which it is used. Applications using the device should be designed so that the absolute maximum ratings will never be exceeded in any operating conditions.

Ensuring that the parameter values remain within these specified ranges during device operation will help to ensure that the integrity of the device is not compromised.

## Electrical Characteristics (unless otherwise specified, VIN = 6 to 16 V, ILOAD-1 = 10 mA, ILOAD-2 = 10 mA, Ta = -40 to 125°C)

Characteristics	Symbol	Applicable Pins	Test Conditions	Min	Typ.	Max	Unit
<b>DC characteristics</b>							
Supply current	I <sub>CC</sub>	VIN1 + VIN2	$\overline{ST} = EN = H$	–	300	500	μA
Standby current	I <sub>CC-stb</sub>		$\overline{ST} = H, EN = L$	–	150	250	
Stop current	I <sub>CC-off</sub>		$\overline{ST} = L$	–	0	10	
<b>Regulator</b>							
Output voltage	V <sub>REG3.3</sub>	V <sub>CC1</sub>	V <sub>SEL1</sub> = H, V <sub>SEL2</sub> = H	3.3	3.4	3.5	V
	V <sub>REG2.5</sub>	V <sub>CC1</sub>	V <sub>SEL1</sub> = H, V <sub>SEL2</sub> = L	2.45	2.55	2.65	
	V <sub>REG1.5</sub>	V <sub>CC1</sub>	V <sub>SEL1</sub> = L, V <sub>SEL2</sub> = L	1.48	1.55	1.62	
	V <sub>REG5.0</sub>	V <sub>CC2</sub>	–	4.88	5.0	5.12	
Output current	I <sub>OUT</sub>	OUT1, OUT2	–	10	–	–	mA
Line regulation	V <sub>LINE1</sub> (1)	V <sub>CC1</sub>	VIN1 = 6 to 40 V	–	0.1	0.5	%
	V <sub>LINE2</sub> (1)	V <sub>CC2</sub>	VIN2 = 6 to 40 V	–	0.1	0.5	
	V <sub>LINE1</sub> (2)	V <sub>CC1</sub>	VIN1 = 4 to 5.15 V	–	0.02	0.1	
Load regulation	V <sub>LOAD1</sub>	V <sub>CC1</sub>	I <sub>LOAD</sub> = 1 to 200 mA	–	0.2	1.0	%
	V <sub>LOAD2</sub>	V <sub>CC2</sub>	I <sub>LOAD</sub> = 1 to 300 mA	–	0.2	1.0	
Temperature coefficient	–	V <sub>CC1</sub> , V <sub>CC2</sub>	–	–	0.01	–	%/°C
Current limiter detection	V <sub>LIMIT</sub>	V <sub>CC1</sub> -V <sub>S1</sub> , V <sub>CC2</sub> -V <sub>S2</sub>	–	0.225	0.300	0.375	V
<b>Mode Select</b>							
Input current	I <sub>IN</sub>	$\overline{ST}$	VIN (ST) = 14 V	25	50	100	μA
Input voltage	V <sub>IH</sub>		–	2	–	–	V
	V <sub>IL</sub>		–	–	–	0.5	
Input current	I <sub>IN</sub>	EN	VIN (EN) = 14 V	25	50	100	μA
Input voltage	V <sub>IH</sub>		–	2	–	–	V
	V <sub>IL</sub>		–	–	–	0.5	
Input current	I <sub>IN</sub>	V <sub>SEL1</sub> V <sub>SEL2</sub>	VIN (V <sub>SEL</sub> ) = 3.4 V	5	10	20	μA
Input voltage	V <sub>IH</sub>		–	1.0	–	–	V
	V <sub>IL</sub>		–	–	–	0.3	
Input voltage difference	ΔV <sub>TH-SEL</sub>	V <sub>SEL1</sub> V <sub>SEL2</sub>	V <sub>TH</sub> (V <sub>SEL2</sub> ) – V <sub>TH</sub> (V <sub>SEL1</sub> )	0.05	0.1	0.15	V

Note: The specification value for supply current is the value measured when I<sub>LOAD</sub> = 0 mA.

## Electrical Characteristics (unless otherwise specified, $V_{IN} = 6$ to $18$ V, $I_{LOAD-1} = 10$ mA, $I_{LOAD-2} = 10$ mA, $T_a = 40$ to $125^\circ\text{C}$ )

Characteristics	Symbol	Applicable Pins	Test Conditions	Min	Typ.	Max	Unit
<b>Reset timer DC characteristics</b>							
Output voltage	VOL	$\overline{\text{RST A}}, \overline{\text{RST B}}$	$I_{OL} = 2$ mA	–	–	0.3	V
Output leakage current	ILEAK		$V_{IN}(\text{RST}) = V_{CC2}$	–	–	5	$\mu\text{A}$
Output voltage	VOL	$\overline{\text{FG}}$	$I_{OL} = 2$ mA	–	–	0.3	V
Output leakage current	ILEAK		$V_{IN}(\text{FG}) = V_{CC2}$	–	–	5	$\mu\text{A}$
Input current	IIN	TC	–	-13	-10	-7	$\mu\text{A}$
Threshold voltage	VIH	TC	–	3.75	4	4.25	V
	VIL		–	1.8	2	2.2	
Input current	IIH	CK	$V_{IN}(\text{CK}) = 5$ V	10	20	40	$\mu\text{A}$
	IIL		$V_{IN}(\text{CK}) = 0$ V	–	–	10	
Input voltage	VIH	CK	–	$0.8 \times V_{CC2}$	–	–	V
	VIL		–	–	–	$0.2 \times V_{CC2}$	
Input current	IIH	WS	$V_{IN}(\text{WS}) = 5$ V	10	20	40	$\mu\text{A}$
	IIL		$V_{IN}(\text{WS}) = 0$ V	–	–	10	
Input voltage	VIH	WS	–	$0.8 \times V_{CC2}$	–	–	V
	VIL		–	–	–	$0.2 \times V_{CC2}$	
Reset threshold voltage	VTH3.3	$V_{CC1}$	VREG3.3	3.0	3.15	3.3	V
	$\Delta V_{TH3.3}$		$V_{REG3.3} - V_{TH3.3}$	0.20	0.25	0.30	
	Vhys3.3		$V_{TH3.3(+)} - V_{TH3.3}$	–	0.05	–	
	VTH2.5	$V_{CC1}$	VREG2.5	2.3	2.4	2.5	V
	$\Delta V_{TH2.5}$		$V_{REG2.5} - V_{TH2.5}$	0.10	0.15	0.20	
	Vhys2.5		$V_{TH2.5(+)} - V_{TH2.5}$	–	0.04	–	
	VTH1.5	$V_{CC1}$	VREG1.5	1.35	1.41	1.47	V
	$\Delta V_{TH1.5}$		$V_{REG1.5} - V_{TH1.5}$	0.10	0.14	0.18	
	Vhys1.5		$V_{TH1.5(+)} - V_{TH1.5}$	–	0.03	–	
	VTH5	$V_{CC2}$	–	4.5	4.7	4.9	V
	$\Delta V_{TH5}$		$V_{REG5.0} - V_{TH5}$	0.25	0.30	0.35	
	Vhys5		$V_{TH5(+)} - V_{TH5}$	–	0.10	–	
"L" Hold voltage of reset output	VRLo	$V_{CC2}$	*see note3	–	–	1.5	V
<b>Reset timer AC characteristics</b>							
Power-on reset	TPOR	$\overline{\text{RST A}}, \overline{\text{RST B}}$	–	$280 \times \text{CT}$	$400 \times \text{CT}$	$520 \times \text{CT}$	ms
Watchdog timer	TWD	$\overline{\text{RST A}}$	–	$140 \times \text{CT}$	$200 \times \text{CT}$	$260 \times \text{CT}$	ms
Reset timer	TRST		–	$0.3 \times \text{CT}$	$0.7 \times \text{CT}$	$1.5 \times \text{CT}$	
Clock pulse width	TW	CK	–	3	–	–	$\mu\text{s}$

Note 1: The units for CT are  $\mu\text{F}$ .

Note 2: The specification values for power-on reset, watchdog timer and reset timer above are intended to guarantee only for this IC. Note that the fluctuations of the CT value should be taken into consideration for practical use of the IC.

Note 3: VCC2 threshold voltage which  $\overline{\text{RST A}}$  or  $\overline{\text{RST B}}$  can output "L"-level when  $V_{\text{CC2}}$  level rises or falls.

Reference Characteristics

Current limiter detection voltage characteristics  
 $V_{CC1}$

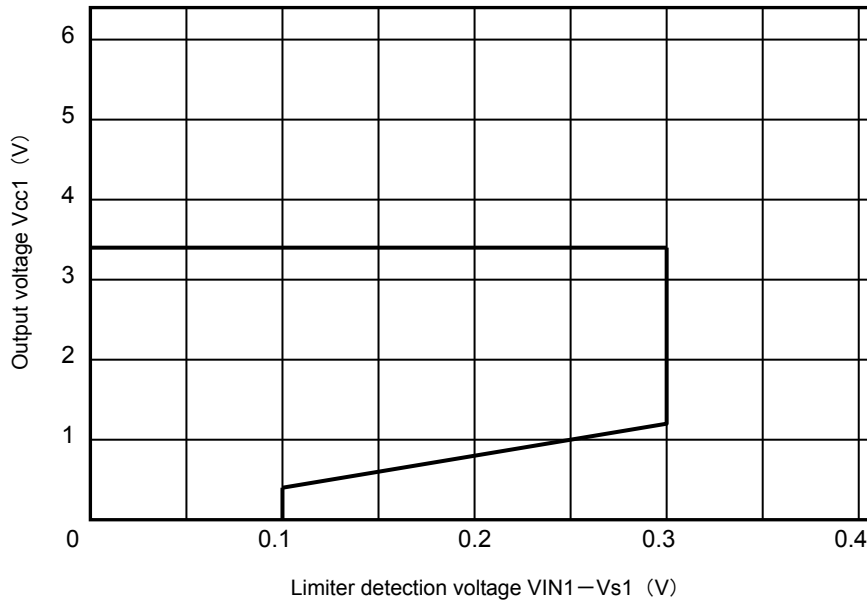

Current limiter detection voltage characteristics  
 $V_{CC2}$

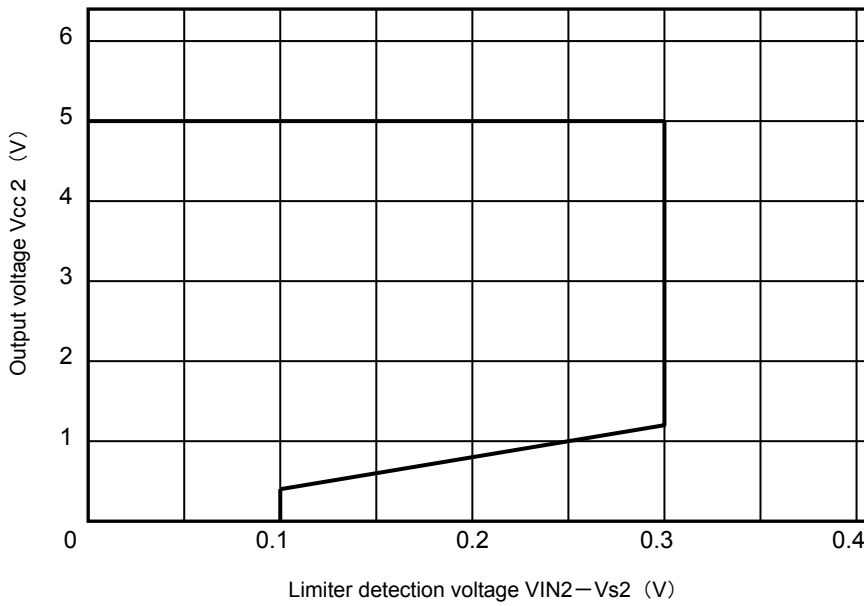

**Table of Truth Value(1)**

Input				Output		Mode
$\overline{ST}$	EN	VSEL1	VSEL2	V <sub>CC1</sub>	V <sub>CC2</sub>	
H	H	L	L	1.5 V	5 V	Active
H	H	H	L	2.5 V	5 V	
H	H	H	H	3.4 V	5 V	
H	L	L	L	1.5 V	0 V (OFF)	Standby
H	L	H	L	2.5 V	0 V (OFF)	
H	L	H	H	3.4 V	0 V (OFF)	
L	Don't Care	Don't Care	Don't Care	0 V (OFF)	0 V (OFF)	Stop

**Table of Truth Value(2) (V<sub>CC1</sub> states during normal operation and when V<sub>SEL1/2</sub> is open)**

Normal Operation			Pin is Open	
VSEL1	VSEL2	V <sub>CC1</sub>	Open Pin	V <sub>CC1</sub>
L	L	1.5 V	VSEL1	1.5 V
			VSEL2	1.5 V
H	L	2.5 V	VSEL1	1.5 V
			VSEL2	2.5 V
H	H	3.4 V	VSEL1	1.5 V
			VSEL2	2.5 V

## Test Mode

Driving VSEL1 low and VSEL2 high causes the TB9004FNG to enter test mode for evaluating and inspecting the IC.

This function must not be used in an actual application.

The input V<sub>TH</sub> for VSEL1 is 0.1 V (typ.) lower than that for VSEL2. The difference is specified as  $\Delta V_{TH-SEL}$  in the electrical characteristics. If voltage is applied with VSEL1 and VSEL2 short-circuited, the VSEL1/2 states can only become L/L, H/L or H/H, thus preventing the IC from entering test mode. When set VSEL1 or VSEL2 to L, please connect to GND.

**Examples of Application Circuit**

Example (1) 5V/1.5 V constant-voltage output power supply, 5V/1.5V parallel connection.

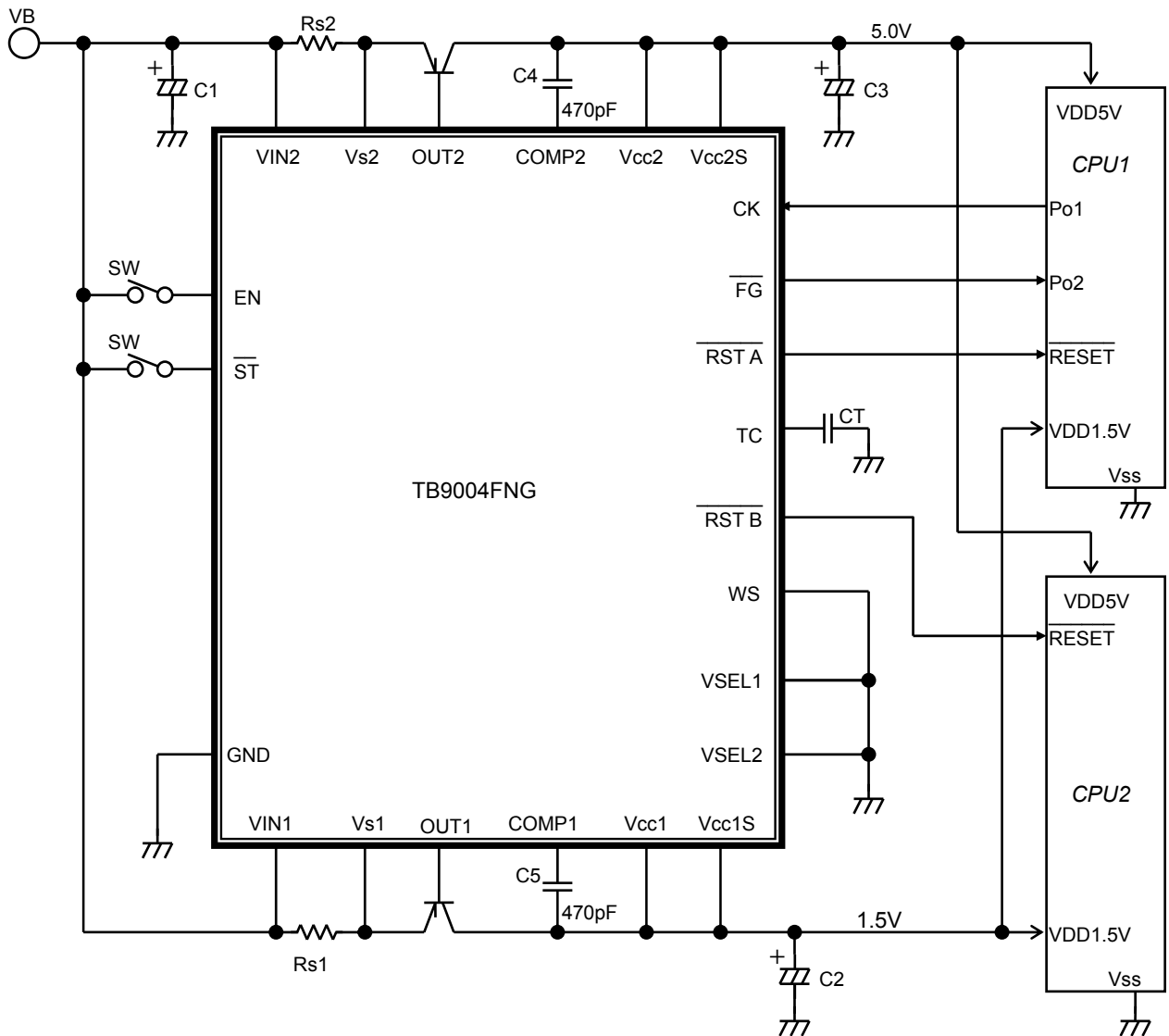

Example (2) 5V/3.4 V constant-voltage output power supply, 5V/3.4V parallel connection.

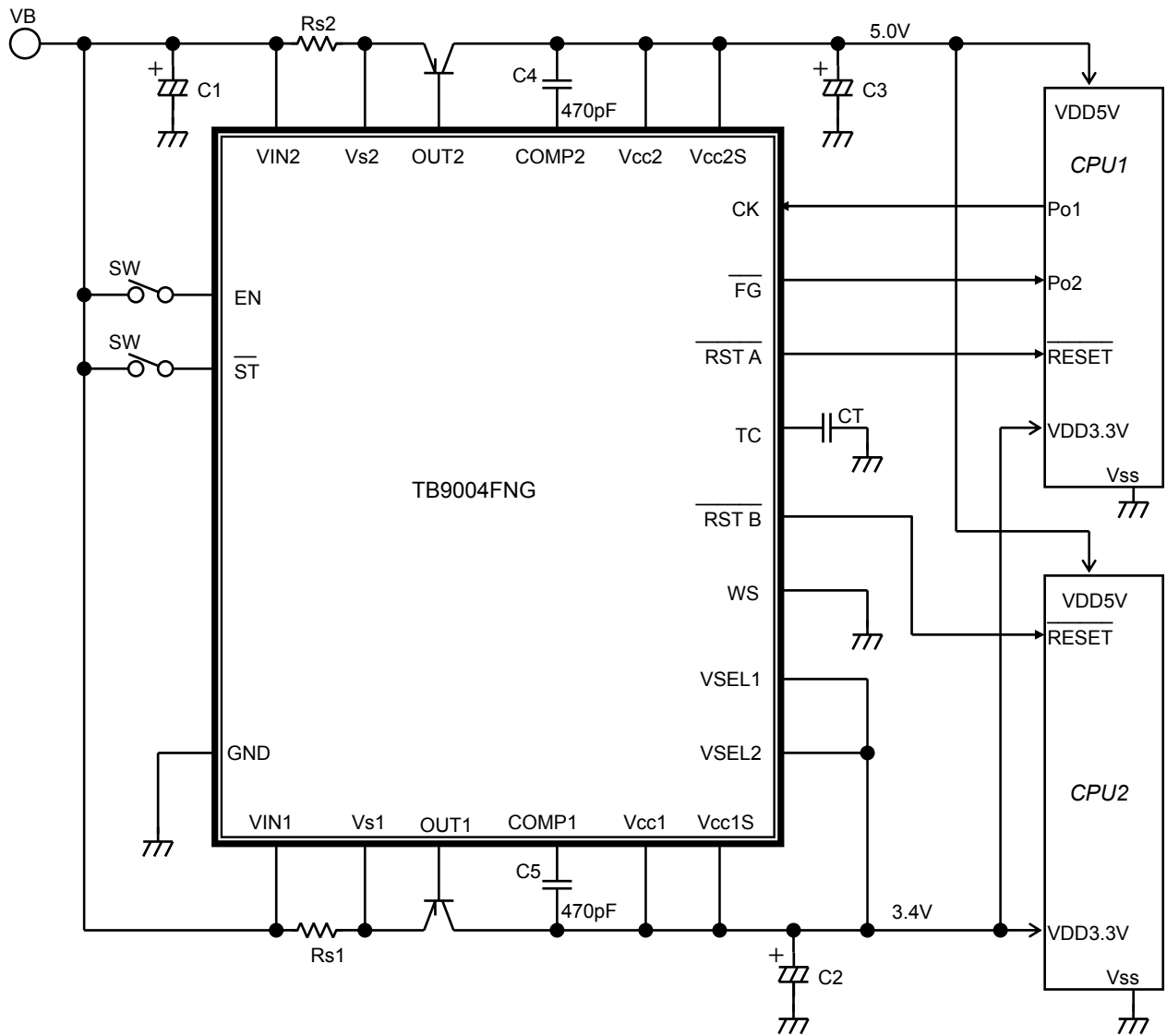

Example (3) 5V/1.5 V constant-voltage output power supply, 5V/1.5V series connection.

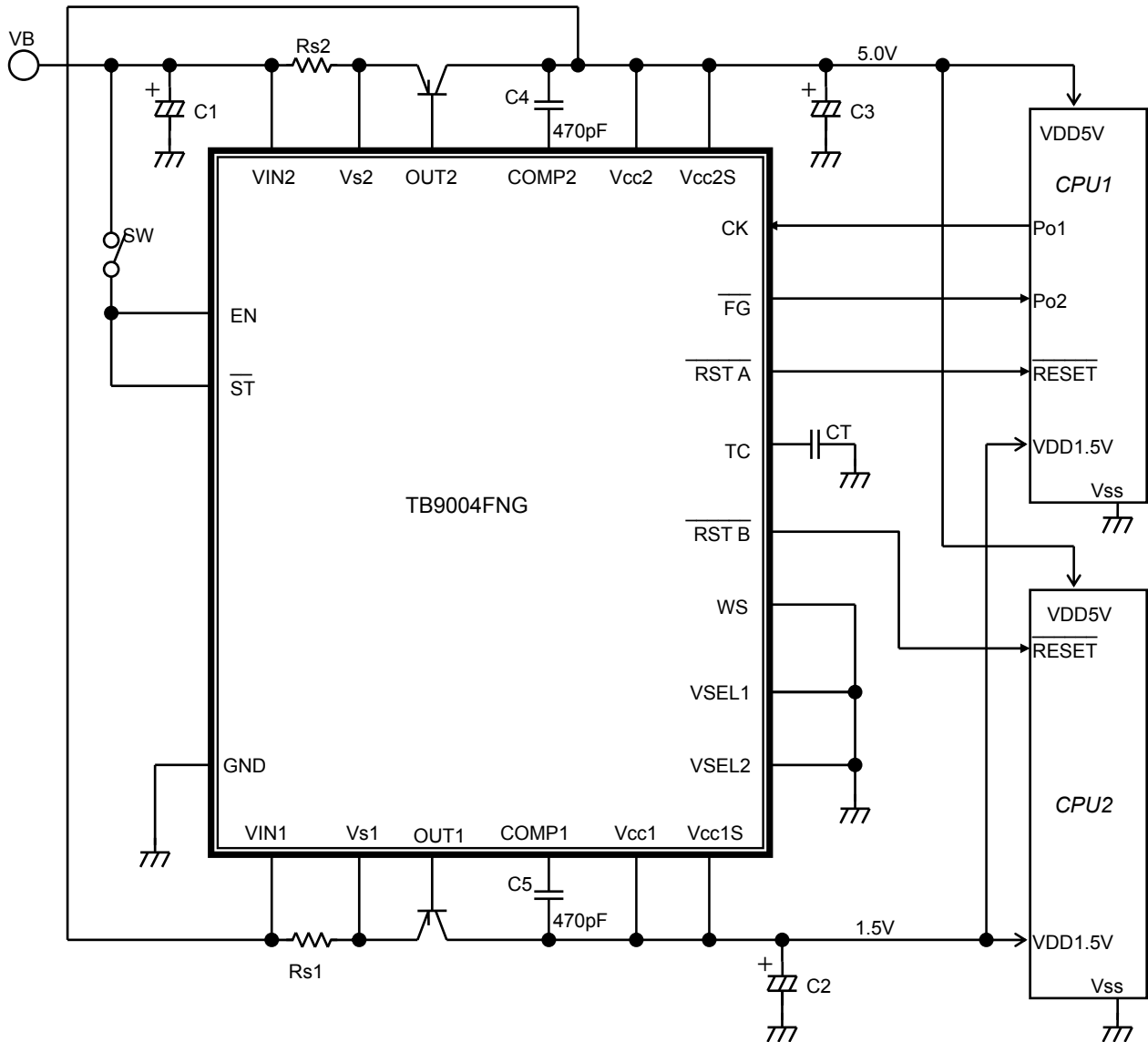

Note 1: Caution for wiring

C1, C2 and C3 are capacitors for absorbing disturbance noise, etc. Connect them as close to the IC as possible. C4 and C5 are capacitors for phase compensation. Connect them as close to the IC as possible.

Note 2: Ensure that the IC is mounted correctly as specified. Failing to observe the correct mounting procedure or requirements may result in the IC or target equipment being damaged.

Note 3: The example application circuit is not guaranteed for mass production. Additional thorough evaluation is required if the device is used in an application intended for mass production.

**Recommended Conditions**

Part Name	Min	Max	Unit
CT	0.01	10	μF

**Package Dimensions**

Unit : mm

SSOP24-P-300-0.65A

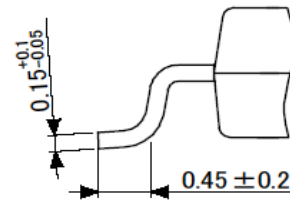
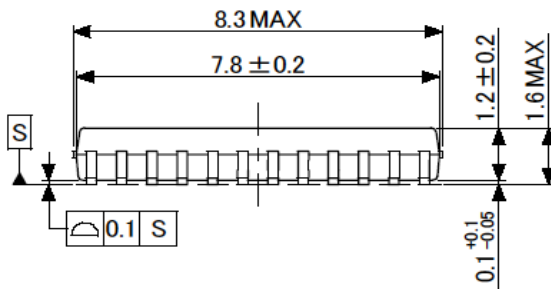
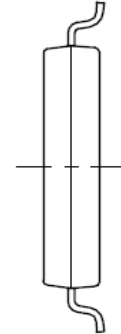
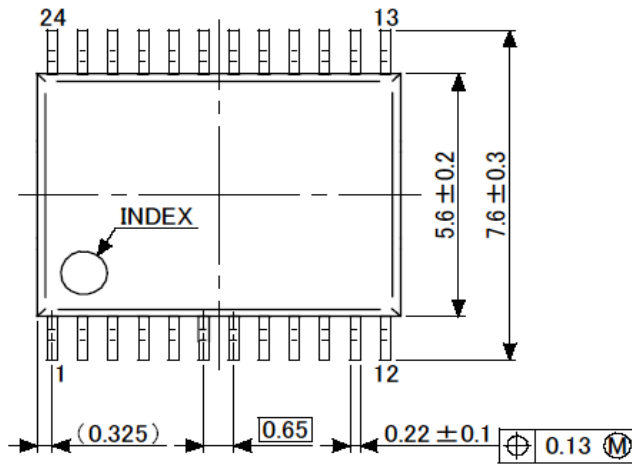

Weight: 0.14 g (typ.)

## RESTRICTIONS ON PRODUCT USE

- Toshiba Corporation, and its subsidiaries and affiliates (collectively "TOSHIBA"), reserve the right to make changes to the information in this document, and related hardware, software and systems (collectively "Product") without notice.
- This document and any information herein may not be reproduced without prior written permission from TOSHIBA. Even with TOSHIBA's written permission, reproduction is permissible only if reproduction is without alteration/omission.
- Though TOSHIBA works continually to improve Product's quality and reliability, Product can malfunction or fail. Customers are responsible for complying with safety standards and for providing adequate designs and safeguards for their hardware, software and systems which minimize risk and avoid situations in which a malfunction or failure of Product could cause loss of human life, bodily injury or damage to property, including data loss or corruption. Before customers use the Product, create designs including the Product, or incorporate the Product into their own applications, customers must also refer to and comply with (a) the latest versions of all relevant TOSHIBA information, including without limitation, this document, the specifications, the data sheets and application notes for Product and the precautions and conditions set forth in the "TOSHIBA Semiconductor Reliability Handbook" and (b) the instructions for the application with which the Product will be used with or for. Customers are solely responsible for all aspects of their own product design or applications, including but not limited to (a) determining the appropriateness of the use of this Product in such design or applications; (b) evaluating and determining the applicability of any information contained in this document, or in charts, diagrams, programs, algorithms, sample application circuits, or any other referenced documents; and (c) validating all operating parameters for such designs and applications. **TOSHIBA ASSUMES NO LIABILITY FOR CUSTOMERS' PRODUCT DESIGN OR APPLICATIONS.**
- Product is intended for use in general electronics applications (e.g., computers, personal equipment, office equipment, measuring equipment, industrial robots and home electronics appliances) or for specific applications as expressly stated in this document. Product is neither intended nor warranted for use in equipment or systems that require extraordinarily high levels of quality and/or reliability and/or a malfunction or failure of which may cause loss of human life, bodily injury, serious property damage or serious public impact ("Unintended Use"). Unintended Use includes, without limitation, equipment used in nuclear facilities, equipment used in the aerospace industry, medical equipment, equipment used for automobiles, trains, ships and other transportation, traffic signaling equipment, equipment used to control combustions or explosions, safety devices, elevators and escalators, devices related to electric power, and equipment used in finance-related fields. Do not use Product for Unintended Use unless specifically permitted in this document.
- Do not disassemble, analyze, reverse-engineer, alter, modify, translate or copy Product, whether in whole or in part.
- Product shall not be used for or incorporated into any products or systems whose manufacture, use, or sale is prohibited under any applicable laws or regulations.
- The information contained herein is presented only as guidance for Product use. No responsibility is assumed by TOSHIBA for any infringement of patents or any other intellectual property rights of third parties that may result from the use of Product. No license to any intellectual property right is granted by this document, whether express or implied, by estoppel or otherwise.
- **ABSENT A WRITTEN SIGNED AGREEMENT, EXCEPT AS PROVIDED IN THE RELEVANT TERMS AND CONDITIONS OF SALE FOR PRODUCT, AND TO THE MAXIMUM EXTENT ALLOWABLE BY LAW, TOSHIBA (1) ASSUMES NO LIABILITY WHATSOEVER, INCLUDING WITHOUT LIMITATION, INDIRECT, CONSEQUENTIAL, SPECIAL, OR INCIDENTAL DAMAGES OR LOSS, INCLUDING WITHOUT LIMITATION, LOSS OF PROFITS, LOSS OF OPPORTUNITIES, BUSINESS INTERRUPTION AND LOSS OF DATA, AND (2) DISCLAIMS ANY AND ALL EXPRESS OR IMPLIED WARRANTIES AND CONDITIONS RELATED TO SALE, USE OF PRODUCT, OR INFORMATION, INCLUDING WARRANTIES OR CONDITIONS OF MERCHANTABILITY, FITNESS FOR A PARTICULAR PURPOSE, ACCURACY OF INFORMATION, OR NONINFRINGEMENT.**
- Do not use or otherwise make available Product or related software or technology for any military purposes, including without limitation, for the design, development, use, stockpiling or manufacturing of nuclear, chemical, or biological weapons or missile technology products (mass destruction weapons). Product and related software and technology may be controlled under the Japanese Foreign Exchange and Foreign Trade Law and the U.S. Export Administration Regulations. Export and re-export of Product or related software or technology are strictly prohibited except in compliance with all applicable export laws and regulations.
- Please contact your TOSHIBA sales representative for details as to environmental matters such as the RoHS compatibility of Product. Please use Product in compliance with all applicable laws and regulations that regulate the inclusion or use of controlled substances, including without limitation, the EU RoHS Directive. TOSHIBA assumes no liability for damages or losses occurring as a result of noncompliance with applicable laws and regulations.