

TOSHIBA BiCMOS INTEGRATED CIRCUIT SILICON MONOLITHIC FOR AUTOMOTIVE USE

# TB9001FNG

## 5 V Voltage Regulator with Watchdog Timer

The TB9001FNG is specially designed for microcomputer systems. The IC features low standby current, oscillator function for CPU sub-clock and various system reset functions.

With external power transistor, TB9001FNG can supply high output current. As a protective feature, current limiter function is incorporated. For system reset includes low voltage reset, power-on reset, and watchdog timer functions.

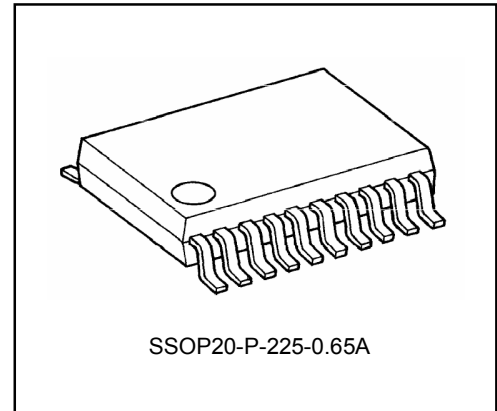

Weight : 0.1g(typ.)

### FEATURES

- Accurate output :  $5.0V \pm 0.15V$
- Low current consumption :  $95\mu A$  ( $V_{IN}=12V$ ,  $T_a=25^\circ C$ ) at 5V output + reset timer + 32kHz sub-clock
- Reset functions : Low voltage reset / power on reset / watchdog timer
- Current limiter : Adjustable with external resistor
- Operating temperature :  $-40\sim 125^\circ C$
- Small SMD package : SSOP-20pin

### About solderability, the following conditions were confirmed.

#### Solderability

##### (1) Use of Sn-37Pb solder Bath

- solder bath temperature =  $230^\circ C$
- dipping time = 5 seconds
- the number of times = once
- use of R-type flux

##### (2) Use of Sn-3.0Ag-0.5Cu solder Bath

- solder bath temperature =  $245^\circ C$
- dipping time = 5 seconds
- the number of times = once
- use of R-type flux

**BLOCK DIAGRAM AND PIN LAYOUT**

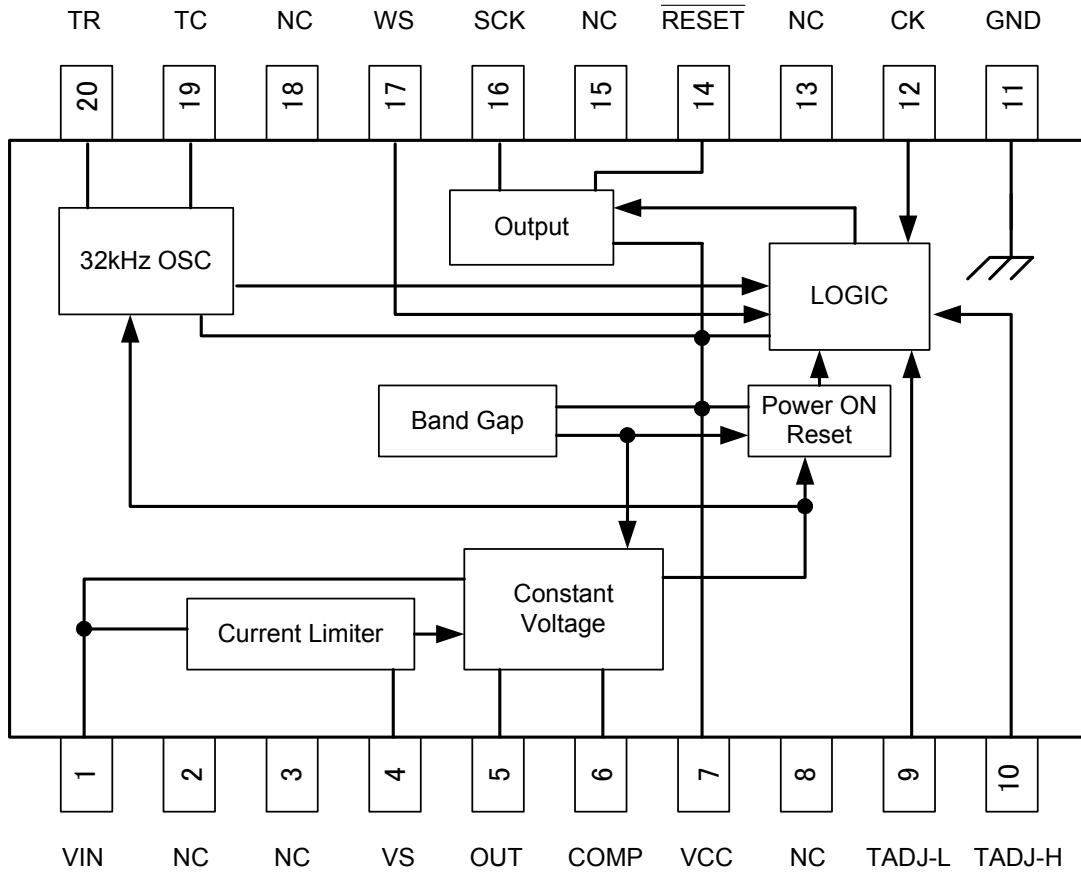

Note: Some of the functional blocks, circuits, or constants in the block diagram are omitted or simplified to clarify the descriptions of the relevant features.

## PIN DESCRIPTION

PIN No.	SYMBOL	DESCRIPTION
1	VIN	Power supply input pin. It contains current limiter and startup circuit.
4	Vs	Detection pin for the Vcc current limiter. This pin monitors any voltage drop occurring in the external resistor Rs between pins VIN and Vs, and the current limiter is actuated when the voltage drop exceeds 0.7 V. Ex.) When the current limiter need to be actuated at a load current of 250mA, $R_s = 0.7 \text{ V} / 250 \text{ mA} = 2.8 \Omega$
5	OUT	This pin is used to connect the base of an external PNP transistor. The output voltage is controlled by an internal op-amp to keep it stable at 5 V. Since the recommended current of Iout is 5 mA, an output current of 300mA can be run if the HFE of the external transistor is 60 or more.
6	COMP	Phase compensating pin for Vcc. Connect a phase compensating capacitor between pin Vcc and this pin.
7	Vcc	Voltage detection pin for the 5 V constant-voltage power supply, Vcc. This pin also supplies power to the reset timer circuit.
9	TADJ-L	Time setup pins for the reset and watchdog timers. For a 32 kHz sub-clock, the time is set by combinations of TADJ-L and TADJ-H. ( These pins must be connected to Vcc or 0V because of logic input.)
10	TADJ-H	<ul style="list-style-type: none"> <li>● TADJ-H = Vcc , TADJ-L = Vcc : TPOR = 50ms , TWD = 50ms , TRST = 5ms</li> <li>● TADJ-H = Vcc , TADJ-L = 0V : TPOR = 200ms , TWD = 100ms , TRST = 10ms</li> <li>● TADJ-H = 0V , TADJ-L = Vcc : TPOR = 50ms , TWD = 25ms , TRST = 2.5ms</li> <li>● TADJ-H = 0V , TADJ-L = 0V : TPOR = 100ms , TWD = 50ms , TRST = 5ms</li> </ul>
11	GND	Grounded
12	CK	Clock input pin for the watchdog timer. This pin detects rising edge of the input signal and does not require external coupling capacitor.
14	RESET	Reset output pin for power on reset and watchdog timer. <ul style="list-style-type: none"> <li>● Generates a reset signal that is determined by sub-clock and TADJ pins.</li> <li>● If no clock is fed to the CK input, this pin generates a reset pulse intermittently.</li> </ul> This is an N-MOS drain output with 100 kΩ pull-up resistor.
16	SCK	Sub-clock output pin for CPU.
17	WS	Watchdog timer function ON / OFF control pin. Set to "Low" for active mode and "High" for Inactive mode.
19	TC	Time setup pin for sub-clock. Connect capacitor CT to GND. The time is set using the internal constant current from TR pin.
20	TR	Time setup pin for sub-clock. Connect resistor RT between TC pin and TR pin.
2, 3, 8, 13, 15, 18	NC	Not connected. ( Electrically, these pins are completely open. )

## Functional Description

### · Sub-Clock Oscillation Circuit

This IC has a built-in sub-clock function the basic circuit configuration of which comprises a CR charge-discharge circuit and a detection circuit for oscillator abnormalities. The sub-clock is also used as the source oscillation frequency for the timer functions: power on reset, watchdog, and reset.

### Basic Operation

The resistor  $R_T$  which sets the charge-and-discharge current, is connected between TC and TR pins, and the capacitor  $C_T$  is connected between TC and GND pins. The TC pin is repeatedly charged and discharged between  $V_{CC04}$  and  $V_{CC06}$ . If TC pin or TR pin is shorted to  $V_{cc}$  or GND, the  $\overline{RESET}$  signal goes to LOW.

### External Resistor and Capacitor

$V_{CC06} : V_{cc} \times 0.6$

$V_{CC04} : V_{cc} \times 0.4$

$$f_{osc} (\text{Hz}) = 1 / ((t_1 + t_2) \times 2)$$

$$t_1 = R_T \times C_T \times \ln(V_{CC06} / V_{CC04})$$

$$t_2 = \text{Delay time of internal circuit} \approx 1\mu\text{s}$$

[ Example ]  $C_T = 75\text{pF}$  ,  $R_T = 480\text{k}\Omega$

$$t_1 = 480 \text{ k}\Omega \times 75 \text{ pF} \times \ln(3 \text{ V} / 2 \text{ V}) = 14.6 \mu\text{s}$$

$$f_{osc} = 1 / ((14.6 \mu\text{s} + 1 \mu\text{s}) \times 2) \approx 32.05 \text{ kHz}$$

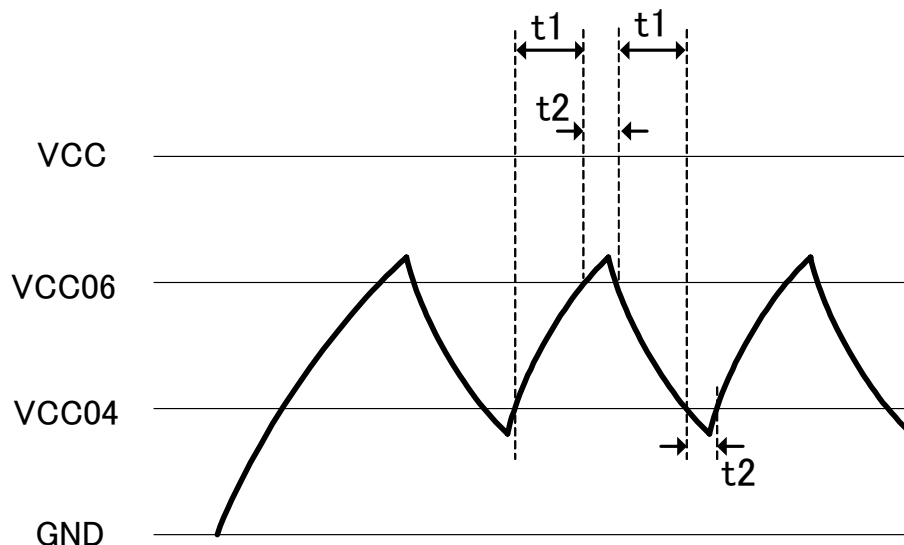

## TIMING CHART

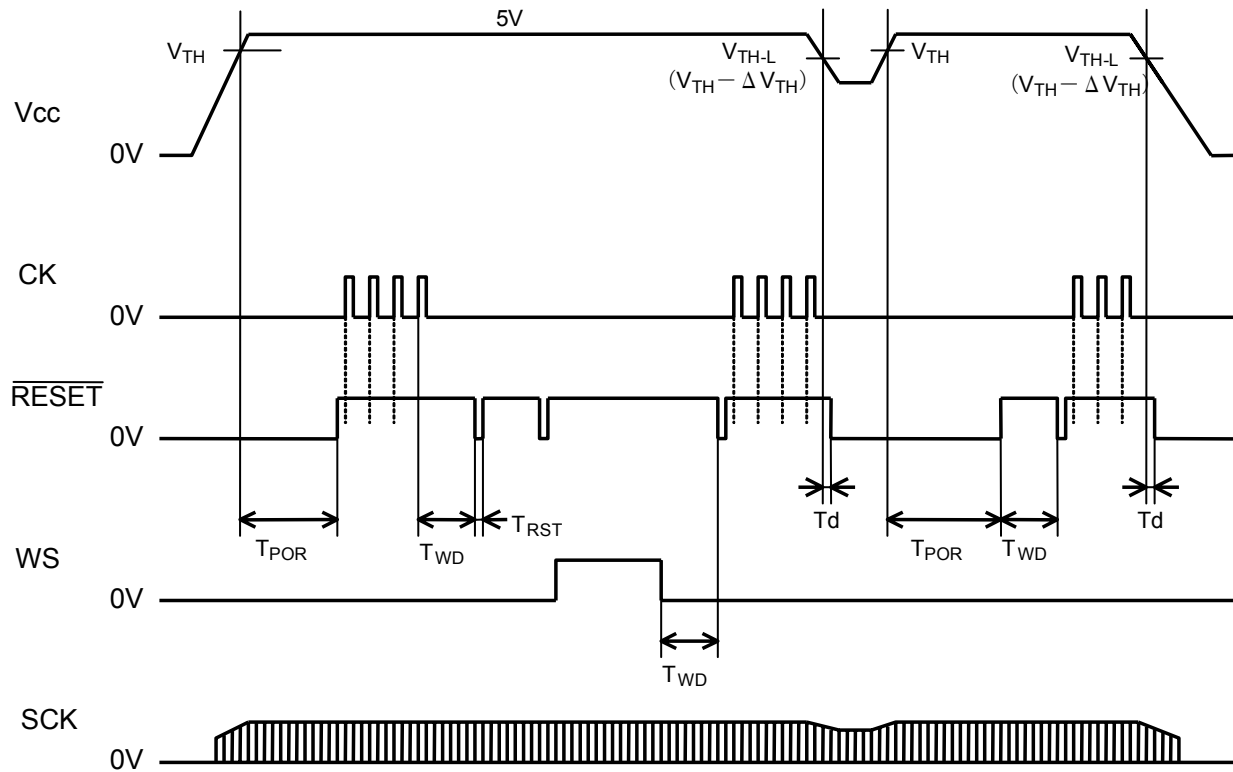

Note1: See ELECTRICAL CHARACTERISTICS about symbols in timing charts.

Note2: Timing charts may be simplified to clarify the descriptions of features and operations.

### ABSOLUTE MAXIMUM RATING (Ta=25°C)

CHARACTERISTIC	SYMBOL	PIN	RATING	UNIT
Input Voltage	V <sub>IN1</sub>	V <sub>IN</sub> , V <sub>S</sub>	45 (1s)	V
	V <sub>IN2</sub>	V <sub>CC</sub>	6.0	
	V <sub>IN3</sub>	CK, WS, TC, TADJ-H, TADJ-L	V <sub>CC</sub>	
Output Current	I <sub>OUT1</sub>	OUT	5	mA
	I <sub>OUT2</sub>	RESET	5	
	I <sub>OUT3</sub>	SCK	±1	
Output Voltage	V <sub>OUT1</sub>	OUT	45 (1s)	V
	V <sub>OUT2</sub>	RESET, SCK	V <sub>CC</sub>	
Operating Temperature	T <sub>opr</sub>	-	-40~125	°C
Storage Temperature	T <sub>stg</sub>	-	-55~150	°C

Note: The absolute maximum ratings of a semiconductor device are a set of specified parameter values that must not be exceeded during operation, even for an instant.

If any of these levels is exceeded during operation, the electrical characteristics may be irreparably altered and the reliability and lifetime of the device can no longer be guaranteed, possibly causing damage to any other equipment with which it is used. Applications using the device should be designed so that the absolute maximum ratings will never be exceeded in any operating conditions.

Ensuring that the parameter values remain within these specified ranges during device operation will help to ensure that the integrity of the device is not compromised.

## ELECTRICAL CHARACTERISTICS ( VIN=6~16V , ILOAD=10mA , Ta=-40~125°C )

CHARACTERISTIC	SYMBOL	PIN	TEST CONDITION	MIN.	TYP.	MAX.	UNIT
Output Voltage	VREG	Vcc	Ta=-40~105°C	4.85	5.0	5.15	V
			Ta=-40~125°C	4.82	5.0	5.15	
Line Regulation	VLINE	Vcc	VIN=6~40V	-	0.1	0.5	%
Load Regulation	VLOAD	Vcc	ILOAD=1~200mA	-	0.2	1.0	%
Temperature Coefficient	-	Vcc		-	0.01	-	%/°C
Output Voltage	VOL	RESET	IOL=2mA	-	-	0.3	V
Output Leakage Current	ILEAK	RESET	VIN(RESET)=Vcc	-	-	5	μA
Threshold Voltage	VIH	TC		-	Vcc X60%	-	V
	VIL			-	Vcc X40%	-	
Input Current	IIN	TADJ-H/L	VIN(TADJ-H/L)=0~Vcc	-5	-	5	μA
Input Voltage	VIH	TADJ-H/L		0.8Vcc	-	-	V
	VIL			-	-	0.2Vcc	
Input Current	IIN	CK	VIN(CK)=0~Vcc	-5	-	5	μA
Input Voltage	VIH	CK		0.8Vcc	-	-	V
	VIL			-	-	0.2Vcc	
Input Current	IIN	WS	VIN(WS)=0~Vcc	-5	-	5	μA
Input Voltage	VIH	WS		0.8Vcc	-	-	V
	VIL			-	-	0.2Vcc	
Output Voltage	VOH	SCK	IOH=-1mA	Vcc-0.5	-	-	V
	VOL		IOL=+1mA	-	-	0.5	
Current Limiter Detection	VLIMIT	Vcc		0.385	0.7	0.945-	V
Current Consumption	Icc	-	Ta=25°C ( VIN = 12V ) *1	-	95	140	μA
			Ta=-40~125°C ( VIN = 12V ) *1	-	95	150	
Reset Detection Voltage	VTH-L	Vcc		4.22	4.40	4.55	V
	ΔVTH			Hys	0.05	0.15	
Power On Reset	TPOR-HH	RESET	TADJ-H=Vcc, -L=Vcc	42.5	50.0	57.5	ms
	TPOR-HL		TADJ-H=Vcc, -L=0V	170	200	230	
	TPOR-LH		TADJ-H=0V, -L=Vcc	42.5	50.0	57.5	
	TPOR-LL		TADJ-H=0V, -L=0V	85	100	115	
Watchdog Timer	TWD-HH	RESET	TADJ-H=Vcc, -L=Vcc	42.5	50.0	57.5	ms
	TWD-HL		TADJ-H=Vcc, -L=0V	85	100	115	
	TWD-LH		TADJ-H=0V, -L=Vcc	21.25	25.00	28.75	
	TWD-LL		TADJ-H=0V, -L=0V	42.5	50.0	57.5	
Reset Timer	TRST-HH	RESET	TADJ-H=Vcc, -L=Vcc	4	5	6	ms
	TRST-HL		TADJ-H=Vcc, -L=0V	8	10	12	
	TRST-LH		TADJ-H=0V, -L=Vcc	2	2.5	3	
	TRST-LL		TADJ-H=0V, -L=0V	4	5	6	
Reset Delay Time	td	RESET		-	10	-	μs
Oscillator	fosc	SCK	*1	27.2	32.0	36.8	kHz
Clock Pulse Width	Tw	CK		3	-	-	μs

\*1 : RT=480kΩ , CT=75pF

The rated value for current consumption is the value that applies when the load current ILOAD=0mA.

\*2 : The rated oscillator frequency, power-on reset, watchdog timer and reset timer values are guaranteed only for the IC itself and do not include any variation caused by external CT and RT components. Such variation should be taken into account in the practical application of the IC.

## RECOMMENDED CONDITION

Part Name	CT(min) & RT(max)	CT(typ) & RT(typ)	CT(max) & RT(min)	Unit
CT	36	75	750	pF
RT	1000	480	48	kΩ

## EXAMPLE OF APPLICATION CIRCUIT

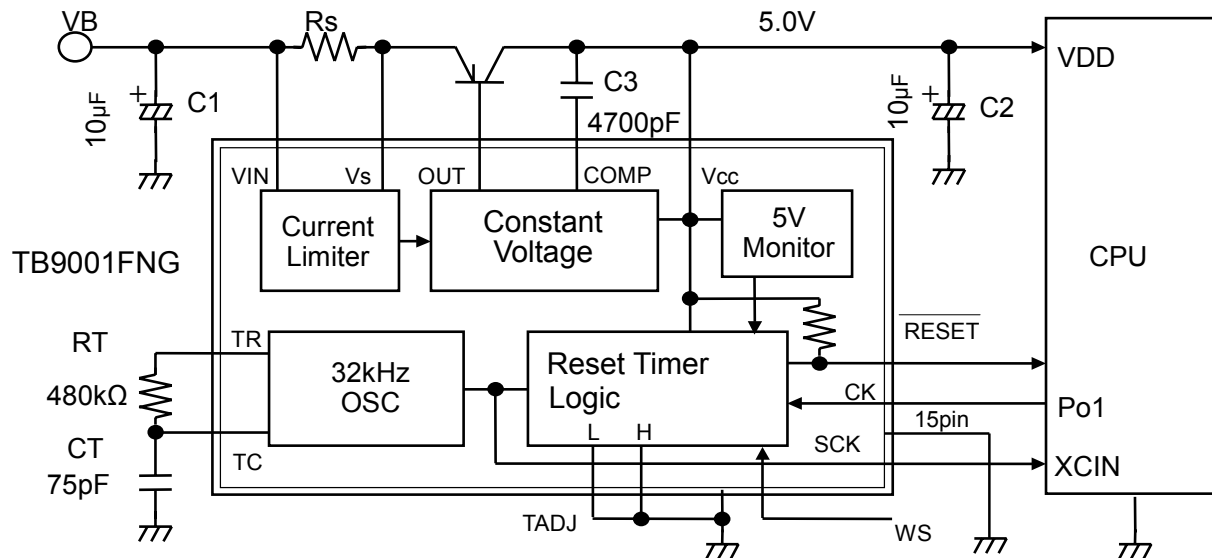

**Note1: Caution for Wiring**

C1 and C2 are for absorbing disturbance, noise, etc. Connect them as close to the IC as possible.  
 C3 is for phase compensation. As with C1 and C2 above, connect C3 as close to the IC as possible.  
 Connect 15-pin NC terminal to Gnd to minimize the influence from SCK pin on other pins.

**Note2:** Ensure that the IC is mounted correctly. Failing to do so may result in the IC or target equipment being damaged.

**Note3:** The application circuit shown above is not intended to guarantee mass production.

A thorough evaluation is required when designing an application circuit for mass production.

## PACKAGE DIMENSION

Unit : mm

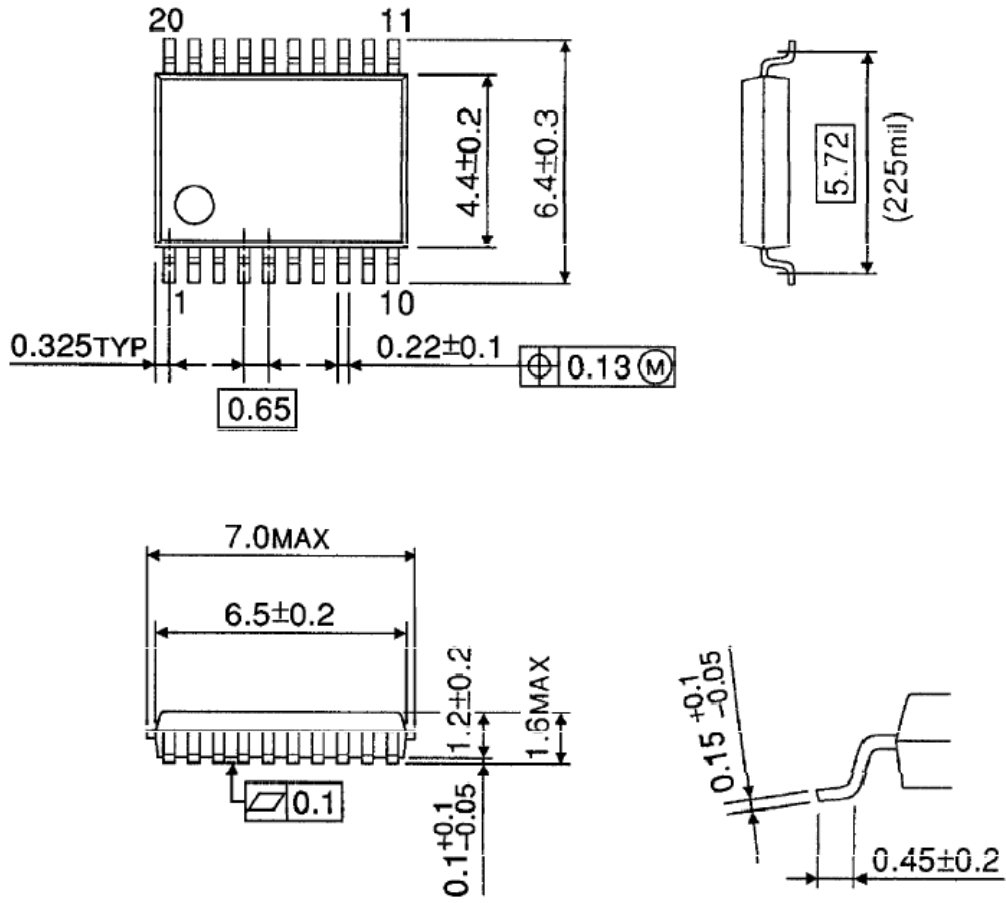

**RESTRICTIONS ON PRODUCT USE**

070313EBA\_S

- The information contained herein is subject to change without notice. 021023\_D
- TOSHIBA is continually working to improve the quality and reliability of its products. Nevertheless, semiconductor devices in general can malfunction or fail due to their inherent electrical sensitivity and vulnerability to physical stress. It is the responsibility of the buyer, when utilizing TOSHIBA products, to comply with the standards of safety in making a safe design for the entire system, and to avoid situations in which a malfunction or failure of such TOSHIBA products could cause loss of human life, bodily injury or damage to property.  
In developing your designs, please ensure that TOSHIBA products are used within specified operating ranges as set forth in the most recent TOSHIBA products specifications. Also, please keep in mind the precautions and conditions set forth in the "Handling Guide for Semiconductor Devices," or "TOSHIBA Semiconductor Reliability Handbook" etc. 021023\_A
- The TOSHIBA products listed in this document are designed and manufactured for usage in automotive electronic equipment. These TOSHIBA products are neither intended nor warranted for usage in equipment other than automotive electronic equipment that requires extraordinarily high quality and/or reliability or a malfunction or failure of which may cause loss of human life or bodily injury ("Unintended Usage"). Unintended Usage includes atomic energy control instruments, airplane or spaceship instruments, transportation instruments, traffic signal instruments, combustion control instruments, medical instruments, all types of safety devices, etc.. TOSHIBA products listed in this document shall not be used for other than automotive electronic equipment such as the applications listed above. 070313\_AG
- The products described in this document shall not be used or embedded to any downstream products of which manufacture, use and/or sale are prohibited under any applicable laws and regulations. 060106\_Q
- The information contained herein is presented only as a guide for the applications of our products. No responsibility is assumed by TOSHIBA for any infringements of patents or other rights of the third parties which may result from its use. No license is granted by implication or otherwise under any patents or other rights of TOSHIBA or the third parties. 070122\_C
- The products described in this document are subject to foreign exchange and foreign trade control laws. 060925\_E