

TOSHIBA BiCMOS Integrated Circuit Silicon Monolithic

# TB9000AFG

## 5 V Voltage Regulator with Watchdog Timer

The TB9000AFG is an IC specially designed for microcomputer systems in automobiles. It features low standby current and various system reset functions.

With an external pass Tr., the TB9000AFG can supply a high output current. A current limiter function is incorporated as a protective function.

System reset includes low-voltage reset, power-on reset, and watchdog timer functionality.

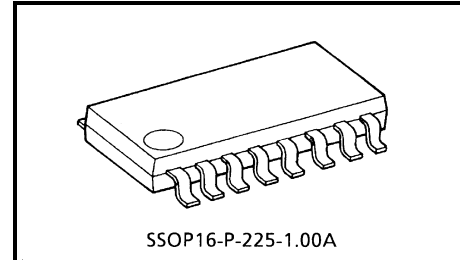

Weight: 0.14 g (typ.)

### Features

- Accurate output:  $5.0\text{ V} \pm 0.15\text{ V}$
- Low current consumption:  $120\ \mu\text{A}$  ( $V_{\text{IN}} = 12\text{ V}$ ,  $T_a = 25^\circ\text{C}$ ) at 5 V output + reset timer
- Reset functions: Low-voltage reset/power-on reset/watchdog timer
- Current limiter: Adjustable with external resistor
- Operating temperature:  $-40$  to  $125^\circ\text{C}$
- Small SMD package: SSOP-16-pin

### About solderability, the following conditions were confirmed.

#### Solderability

##### (1) Use of Sn-37Pb solder Bath

- solder bath temperature =  $230^\circ\text{C}$
- dipping time = 5 seconds
- the number of times = once
- use of R-type flux

##### (2) Use of Sn-3.0Ag-0.5Cu solder Bath

- solder bath temperature =  $245^\circ\text{C}$
- dipping time = 5 seconds
- the number of times = once
- use of R-type flux

**Block Diagram & Pin Layout**

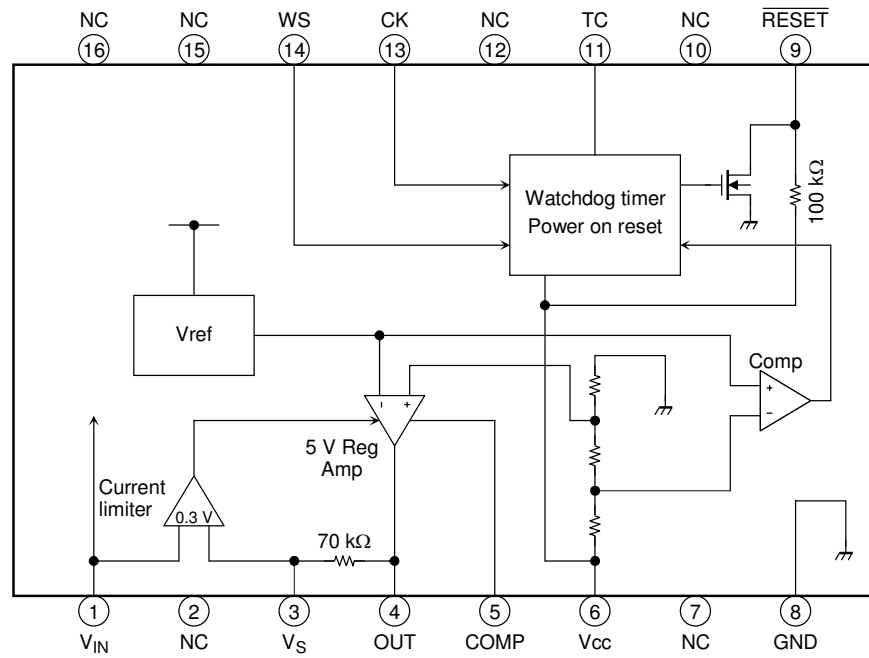

Note: Some functional blocks, circuits, or constants are omitted or simplified in the block diagram to clarify the descriptions of the relevant features.

**Pin Description**

Pin No.	Symbol	Description
1	V <sub>IN</sub>	Power supply input pin. It contains a current limiter and startup circuit.
3	V <sub>S</sub>	Detection pin for the V <sub>CC</sub> current limiter. Any voltage drop occurring in the external resistor R <sub>S</sub> between pins V <sub>IN</sub> and V <sub>S</sub> is monitored. The current limiter is actuated when the voltage drop exceeds 0.3 V. Ex.) When the current limiter need to be actuated at a load current of 600 mA: $R_S = 0.3 \text{ V} / 600 \text{ mA} = 0.5 \Omega$ .
4	OUT	This pin is used to connect the base of an external PNP transistor. The output voltage is controlled by an internal op-amp to maintain it stably at 5 V. Since the recommended I <sub>OUT</sub> current is 8 mA, an output current of 600 mA can be run if H <sub>FE</sub> of the external transistor is 80 or more.
5	COMP	Phase-compensating pin for V <sub>CC</sub> . Connect a phase-compensating capacitor between pin V <sub>CC</sub> and this pin.
6	V <sub>CC</sub>	Voltage detection pin for the 5 V constant-voltage power supply, V <sub>CC</sub> . It also supplies power to the reset timer circuit.
8	GND	Grounded
9	$\overline{\text{RESET}}$	Reset output pin for power-on reset and watchdog timer. Generates a reset signal that is determined by CT at the TC pin. If no clock is fed to the CK input, this pin generates a reset pulse intermittently. This is an N-MOS drain output with a 100 kΩ pull-up resistor to V <sub>CC</sub> .
11	TC	Time setup pin for the reset and watchdog timers. Connect capacitor CT to GND. The time is set up by internal constant current.
13	CK	Clock input pin for the watchdog timer. This pin detects the rising edge of the input signal and does not require external coupling capacitor.
14	WS	Watchdog timer function ON/OFF control pin. Set to LOW for active mode and HIGH for inactive mode.
2, 7, 10, 12, 15, 16	NC	Not connected. (Electrically, this pin is completely open.)

## Functional Description

The TB9000AFG incorporates a constant-voltage 5 V power supply function to feed stable power to the CPU, while the system reset and CPU monitor functions ensure stable operation of the CPU, etc. These functions are explained below.

### (1) Constant-Voltage 5 V Power Supply Function

This constant-voltage function has a reference voltage  $V_{ref}$  in the IC that is insusceptible to temperature changes and input voltage fluctuations. The power supply circuit is designed in such a way that this voltage is stepped up to 5 V by using an OP amp and a voltage-dividing resistor. The OP amp, dividing resistor and an output transistor connected to the OP amp output together configure a closed loop.

An overcurrent protection function is incorporated as a protective measure in case a fault such as shorting to GND occurs in the 5 V output. A current detecting resistor is inserted between the  $V_{IN}$  and the  $V_S$  pins, and a voltage drop across this resistor is detected by a comparator, thereby suppressing the operation of the OP amp to ensure that the voltage drop will not exceed 0.3 V. In this way, a current limiter function is actuated to prevent any more current from flowing.

### (2) System Reset Function (see Timing Charts)

- **Voltage monitoring function**

When powered on, the power-on reset timer starts counting the moment the voltage  $V_{CC}$  applied to the CPU exceeds  $V_{TH}$ . When powered off, this voltage monitoring function outputs a reset signal immediately when  $V_{CC}$  drops below  $V_{TH}$ . A reset signal is also output immediately when  $V_{CC}$  drops for some reason during normal operation. Then, when  $V_{CC}$  is restored to the normal voltage and exceeds  $V_{TH}$ , the power-on reset timer starts counting.

The reset signal is output from the  $\overline{RESET}$  pin.

- **Power-on reset timer function**

To allow the 5 V constant voltage to stabilize at power-on, as well as provide sufficient time for the clock oscillation in the CPU to stabilize, the device remains reset for a predetermined time before being released from the reset state. The duration of this time can be set as desired by choosing appropriate values for the external capacitor connected to the TC pin.

The system starts charging the capacitor when the  $V_{CC}$  voltage exceeds  $V_{TH}$ . When this charge voltage exceeds 4 V, the capacitor is discharged by the IC's internal transistor. When the capacitor is discharged down to 2 V, the reset signal is inverted to deactivate the reset.

- **Watchdog timer function**

Program your system to output a clock each time one program routine is finished in the CPU system software, and input this clock to the CK pin of the IC. The IC's TC pin is repeatedly charged and discharged between 2 V and 4 V. However, when a clock is input, it switches over and starts discharging in the middle of charging and then starts charging from 2 V again. Since the clock is generated at predetermined intervals when the CPU system is operating normally, the TC pin switches over and starts discharging before the charge voltage reaches 4 V. However, if no clock is input while being charged from 2 V to 4 V, the clock is assumed to have stopped, i.e., the CPU system has gone wild, so that a reset signal is output to reset the CPU system.

- **Watchdog timer stop function**

The watchdog timer can be switched ON or OFF by use of the WS pin. If the WS pin is fixed to LOW, the watchdog timer will be active. (See Timing Chart 1.) If the WS pin is fixed to HIGH, the watchdog timer will be inactive. (See Timing Chart 2.) When the WS pin is fixed to HIGH, no reset signal is output, in which case only the power-on reset timer is useful.

Note: The overcurrent protection feature is intended only to protect the IC from a temporary short circuit. A short circuit over an extended period of time may place excessive stress on the IC, possibly causing it to be damaged. The system must be configured so that any overcurrent condition will be eliminated as soon as possible.

**Timing Chart 1: WS = LOW**

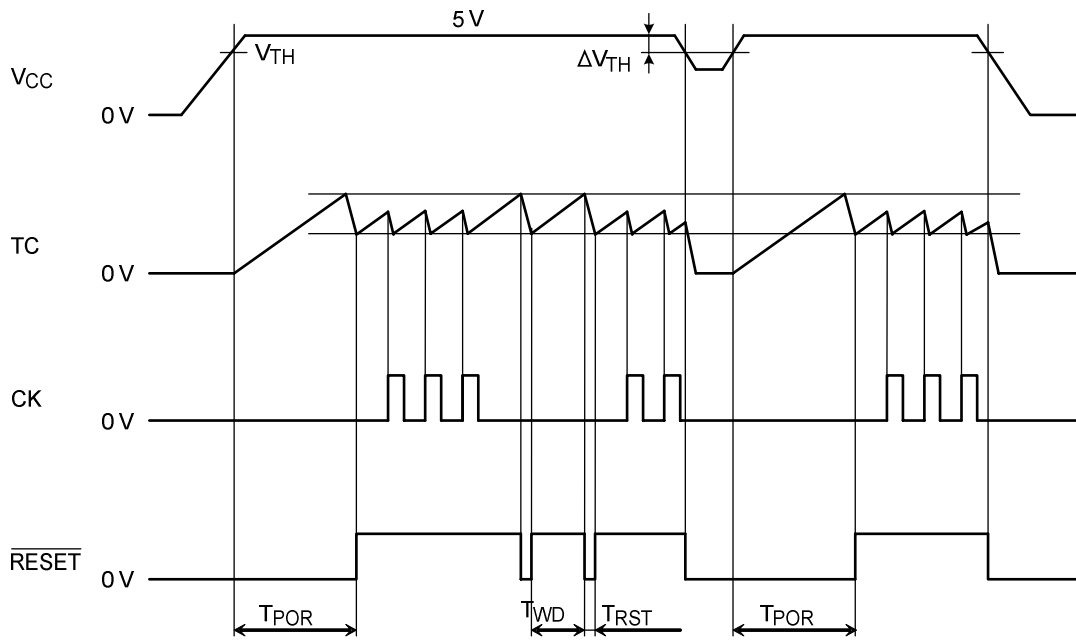

**Timing Chart 2: WS = HIGH**

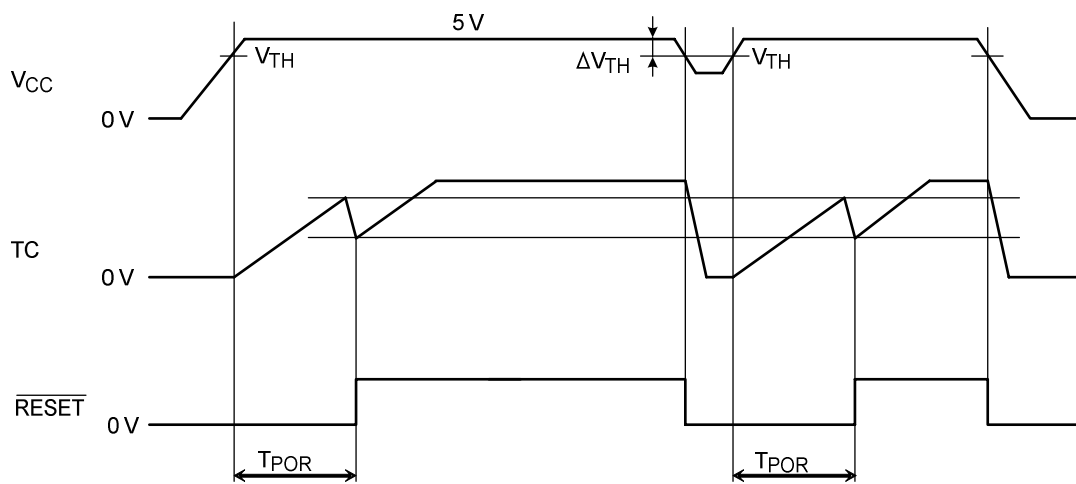

Note 1: Definitions of symbols used in this timing chart are provided in the Electrical Characteristics table.

Note 2: Timing charts may be simplified to clarify the descriptions of features and operations.

## Absolute Maximum Rating (Ta = 25°C)

Characteristics	Symbol	Pin	Rating	Unit
Input voltage	V <sub>IN1</sub>	V <sub>IN</sub> , V <sub>S</sub>	45 (1 s)	V
	V <sub>IN2</sub>	V <sub>CC</sub>	6.0	
	V <sub>IN3</sub>	CK, WS, TC	V <sub>CC</sub>	
Output current	I <sub>OUT1</sub>	OUT	10	mA
	I <sub>OUT2</sub>	$\overline{\text{RESET}}$	5	
Output voltage	V <sub>OUT1</sub>	OUT	45 (1 s)	V
	V <sub>OUT2</sub>	$\overline{\text{RESET}}$	V <sub>CC</sub>	
Operating temperature	T <sub>opr</sub>	–	–40 to 125	°C
Storage temperature	T <sub>stg</sub>	–	–55 to 150	°C

Note: The absolute maximum ratings of a semiconductor device are a set of specified parameter values that must not be exceeded during operation, even for an instant.

If any of these levels is exceeded during operation, the device's electrical characteristics may be irreparably altered and the reliability and lifetime of the device can no longer be guaranteed, possibly causing damage to any other equipment with which it is used. Applications using the device should be designed so that the absolute maximum ratings will never be exceeded in any operating conditions.

Ensuring that the parameter values remain within these specified ranges during device operation will help to ensure that the integrity of the device is not compromised.

## Electrical Characteristics

(Unless otherwise specified,  $V_{IN} = 6$  to  $16$  V,  $I_{LOAD} = 10$  mA,  $T_a = -40$  to  $125^\circ\text{C}$ )

Characteristics	Symbol	Pin	Test Circuit	Test Condition	Min	Typ.	Max	Unit
Output voltage	VREG	$V_{CC}$	-	$T_a = -40$ to $105^\circ\text{C}$	4.85	5.0	5.15	V
				$T_a = -40$ to $125^\circ\text{C}$	4.82	5.0	5.15	
Line regulation	VLINE	$V_{CC}$	-	$V_{IN} = 6$ to $40$ V	-	0.1	0.5	%
Load regulation	VLOAD	$V_{CC}$	-	$I_{LOAD} = 1$ to $300$ mA	-	0.2	1.0	%
Temperature coefficient	-	$V_{CC}$	-		-	0.01	-	%/ $^\circ\text{C}$
Output voltage	VOL	$\overline{\text{RESET}}$	-	$I_{OL} = 2$ mA	-	-	0.3	V
Output leakage current	ILEAK	$\overline{\text{RESET}}$	-	$V_{IN}(\overline{\text{RESET}}) = V_{CC}$	-	-	5	$\mu\text{A}$
Input current	IIN	TC	-	$V_{IN}(\text{TC}) = \text{GND}$	-	-10	-	$\mu\text{A}$
Input current	IIN	CK	-	$V_{IN}(\text{CK}) = 0$ to $V_{CC}$	-5	-	5	$\mu\text{A}$
Input current	IIN	WS	-	$V_{IN}(\text{WS}) = 0$ to $V_{CC}$	-5	-	5	$\mu\text{A}$
Input voltage	$V_{IH}$	CK	-		$0.8 V_{CC}$	-	-	V
	$V_{IL}$			-	-	$0.2 V_{CC}$		
Input voltage	$V_{IH}$	WS	-		$0.8 V_{CC}$	-	-	V
	$V_{IL}$			-	-	$0.2 V_{CC}$		
Current limiter detection	VLIMIT	$V_{IN}, V_S$	-		0.225	0.3	0.375	V
Current consumption	$I_{CC}$	-	-	$T_a = 25^\circ\text{C}, V_{IN} = 12$ V	-	120	170	$\mu\text{A}$
				$T_a = -40$ to $125^\circ\text{C}, V_{IN} = 12$ V	-	120	190	
Reset detection voltage	$V_{TH}$	$V_{CC}$	-		4.0	4.2	4.4	V
	$\Delta V_{TH}$			$V_{CC} - V_{TH}$	0.45	0.80	1.15	
Power-on reset	TPOR	$\overline{\text{RESET}}$	-		$280 \times \text{CT}$	$400 \times \text{CT}$	$520 \times \text{CT}$	ms
Watchdog timer	TWD	$\overline{\text{RESET}}$	-		$140 \times \text{CT}$	$200 \times \text{CT}$	$260 \times \text{CT}$	ms
Reset timer	TRST	$\overline{\text{RESET}}$	-		$4.0 \times \text{CT}$	$8.0 \times \text{CT}$	$12.0 \times \text{CT}$	ms
Clock pulse width	$T_w$	CK	-		3	-	-	$\mu\text{s}$

Note 1: CT is measured in units of  $\mu\text{F}$ .

Note 2: The specification values for power-on reset, watchdog timer and reset timer above are guaranteed only for the IC itself. Any practical application of the IC should take into account fluctuations in the CT value.

Note 3: For the above current consumption  $I_{CC}$ , it is specified that  $I_{LOAD} = 0$  mA.

## Operating Conditions

Part Name	Min	Typ.	Max	Unit
CT	0.01	0.25	10	$\mu\text{F}$

**Reference Characteristics**

Input – Output Characteristics

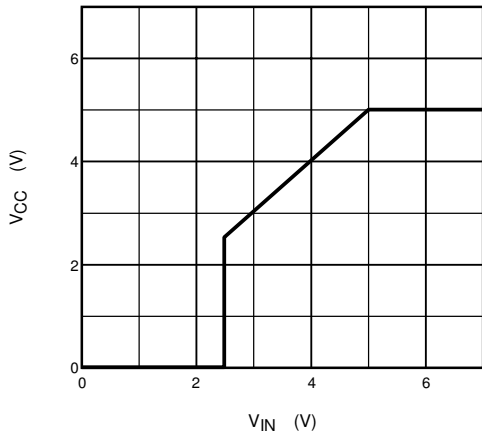

$\overline{RESET}$  Output Characteristics

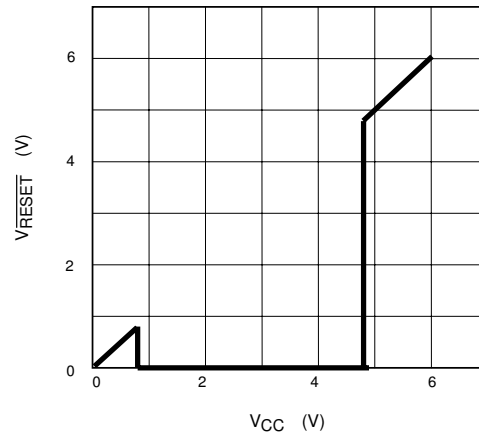

Current Limiter Characteristics

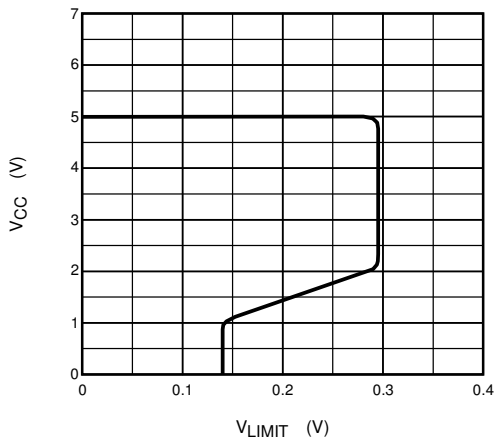

**Example of Application Circuit**

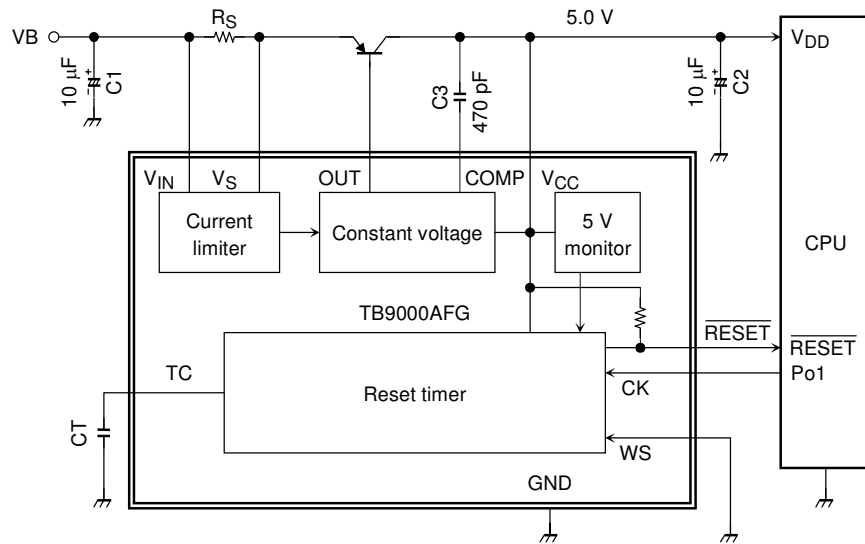

**Caution for Wiring**

- Note 1:  $C_1$  and  $C_2$  are for absorbing disturbances, noise, etc.  $C_3$  is for phase compensation. Connect each capacitor as close to the IC as possible.
- Note 2: Ensure that the IC is mounted correctly. Failure to do so may result in the IC or target equipment being damaged.
- Note 3: The application circuit shown above is not intended to guarantee mass production. A thorough evaluation is required when designing an application circuit for mass production.

## Package Dimensions

SSOP16-P-225-1.00A

Unit : mm

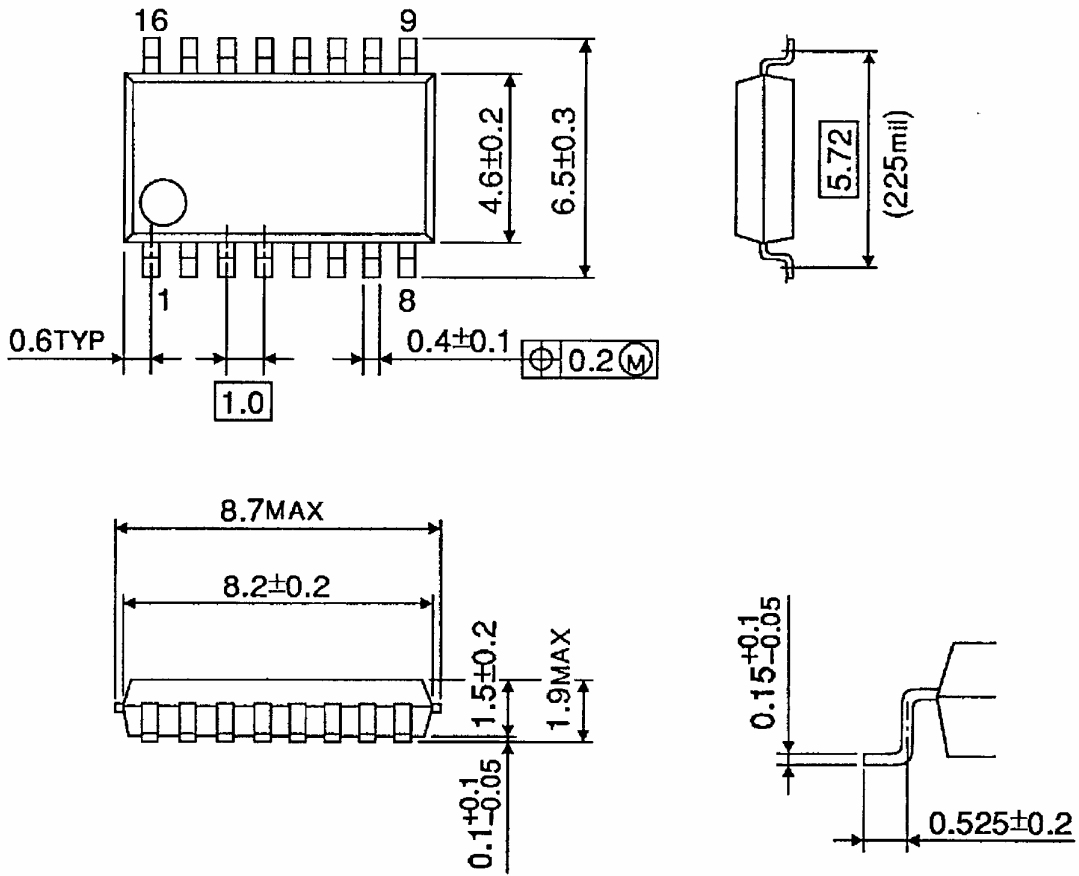

Weight: 0.14 g (typ.)

**RESTRICTIONS ON PRODUCT USE**

070313EBA\_S

- The information contained herein is subject to change without notice. 021023\_D
- TOSHIBA is continually working to improve the quality and reliability of its products. Nevertheless, semiconductor devices in general can malfunction or fail due to their inherent electrical sensitivity and vulnerability to physical stress. It is the responsibility of the buyer, when utilizing TOSHIBA products, to comply with the standards of safety in making a safe design for the entire system, and to avoid situations in which a malfunction or failure of such TOSHIBA products could cause loss of human life, bodily injury or damage to property.  
In developing your designs, please ensure that TOSHIBA products are used within specified operating ranges as set forth in the most recent TOSHIBA products specifications. Also, please keep in mind the precautions and conditions set forth in the "Handling Guide for Semiconductor Devices," or "TOSHIBA Semiconductor Reliability Handbook" etc. 021023\_A
- The TOSHIBA products listed in this document are designed and manufactured for usage in automotive electronic equipment. These TOSHIBA products are neither intended nor warranted for usage in equipment other than automotive electronic equipment that requires extraordinarily high quality and/or reliability or a malfunction or failure of which may cause loss of human life or bodily injury ("Unintended Usage"). Unintended Usage includes atomic energy control instruments, airplane or spaceship instruments, transportation instruments, traffic signal instruments, combustion control instruments, medical instruments, all types of safety devices, etc.. TOSHIBA products listed in this document shall not be used for other than automotive electronic equipment such as the applications listed above. 070313\_AG
- The products described in this document shall not be used or embedded to any downstream products of which manufacture, use and/or sale are prohibited under any applicable laws and regulations. 060106\_Q
- The information contained herein is presented only as a guide for the applications of our products. No responsibility is assumed by TOSHIBA for any infringements of patents or other rights of the third parties which may result from its use. No license is granted by implication or otherwise under any patents or other rights of TOSHIBA or the third parties. 070122\_C
- The products described in this document are subject to foreign exchange and foreign trade control laws. 060925\_E