

TOSHIBA Bipolar Linear Integrated Circuit Silicon Monolithic

## TA78M05F,TA78M06F,TA78M08F,TA78M09F,TA78M10F TA78M12F,TA78M15F,TA78M18F,TA78M20F,TA78M24F

Output Current of 0.5 A, Three-Terminal Positive Voltage Regulators  
5 V, 6 V, 8 V, 9 V, 10 V, 12 V, 15 V, 18 V, 20 V, 24 V

### Features

- Suitable for CMOS, TTL and the power supply of the other digital ICs
- Internal overheating protection.
- Internal overcurrent protection.
- Maximum output current of 0.5 A.
- Packaged in New PW-Mold (Surface-mount type).

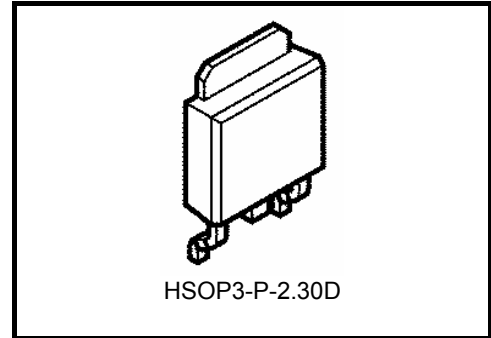

Weight  
HSOP3-P-2.30D: 0.36 g (typ.)

### Pin Assignment

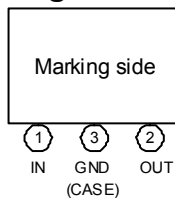

### Marking

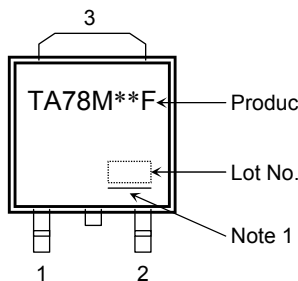

Note 1: A line under a Lot No. identifies the indication of product Labels.

Not underlined: [[Pb]]/INCLUDES > MCV

Underlined: [[G]]/RoHS COMPATIBLE or [[G]]/RoHS [[Pb]]

Please contact your TOSHIBA sales representative for details as to environmental matters such as the RoHS compatibility of Product. The RoHS is the Directive 2002/95/EC of the European Parliament and of the Council of 27 January 2003 on the restriction of the use of certain hazardous substances in electrical and electronic equipment.

Note 2: The “\*\*” part of each product number varies according to the output voltage of the product.

### Ordering Method

Product Name	Package (Lead Type)	Packing Form
TA78M**F (TE16L1, NQ)	New PW-Mold: Surface-mount	Tape (2000 pcs./reel)

Note: The “\*\*” in each pro-forma product name is replaced with the output voltage of each product.

The product(s) in this document (“Product”) contain functions intended to protect the Product from temporary small overloads such as minor short-term overcurrent or overheating. The protective functions do not necessarily protect Product under all circumstances. When incorporating Product into your system, please design the system (1) to avoid such overloads upon the Product, and (2) to shut down or otherwise relieve the Product of such overload conditions immediately upon occurrence. For details, please refer to the notes appearing below in this document and other documents referenced in this document.

## Equivalent Circuit

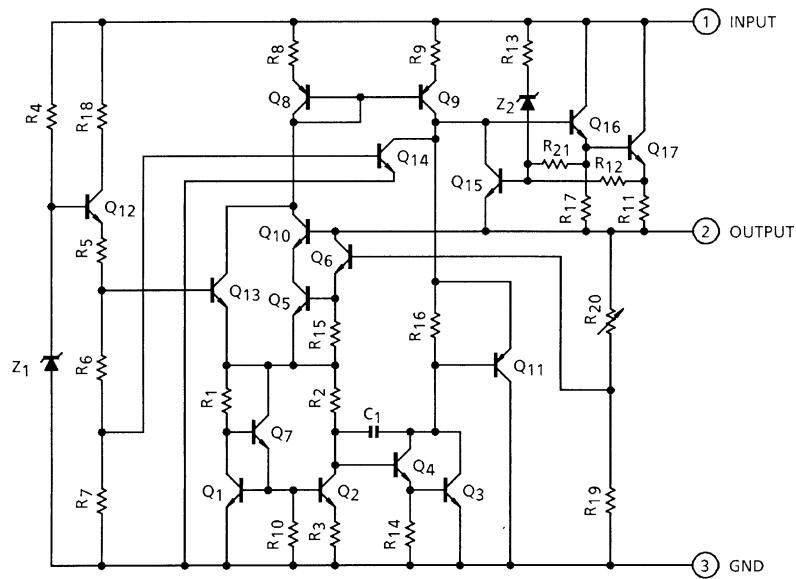

## Absolute Maximum Ratings (Ta = 25°C)

Characteristics		Symbol	Rating	Unit
Input voltage	TA78M05F	$V_{IN}$	35	V
	TA78M06F			
	TA78M08F			
	TA78M09F			
	TA78M10F			
	TA78M12F			
	TA78M15F			
	TA78M18F			
	TA78M20F		40	
	TA78M24F			
Output current		$I_{OUT}$	0.5	A
Power dissipation	(Ta = 25°C)	$P_D$	1	W
	(Tc = 25°C)		10	
Operating junction temperature		$T_{Jopr}$	-30 to 150	°C
Storage temperature		$T_{stg}$	-55 to 150	°C
Junction temperature		$T_j$	150	°C
Thermal resistance		$R_{th(j-c)}$	12.5	°C/W
		$R_{th(j-a)}$	125	

Note: Using continuously under heavy loads (e.g. the application of high temperature/current/voltage and the significant change in temperature, etc.) may cause this product to decrease in the reliability significantly even if the operating conditions (i.e. operating temperature/current/voltage, etc.) are within the absolute maximum ratings and the operating ranges.

Please design the appropriate reliability upon reviewing the Toshiba Semiconductor Reliability Handbook ("Handling Precautions"/"Derating Concept and Methods") and individual reliability data (i.e. reliability test report and estimated failure rate, etc).

## TA78M05F

### Electrical Characteristics

(Unless otherwise specified,  $V_{IN} = 10\text{ V}$ ,  $I_{OUT} = 350\text{ mA}$ ,  $0^\circ\text{C} \leq T_j \leq 125^\circ\text{C}$ ,  $C_{IN} = 0.33\ \mu\text{F}$ ,  $C_{OUT} = 0.1\ \mu\text{F}$ )

Characteristics	Symbol	Test Circuit	Test Condition	Min	Typ.	Max	Unit		
Output voltage	$V_{OUT}$	1	$T_j = 25^\circ\text{C}$	4.8	5.0	5.2	V		
Line regulation	Reg-line	1	$T_j = 25^\circ\text{C}$	$7\text{ V} \leq V_{IN} \leq 25\text{ V}$ , $I_{OUT} = 200\text{ mA}$	—	4	100	mV	
				$8\text{ V} \leq V_{IN} \leq 25\text{ V}$ , $I_{OUT} = 200\text{ mA}$	—	2	50		
Load regulation	Reg-load	1	$T_j = 25^\circ\text{C}$	$5\text{ mA} \leq I_{OUT} \leq 500\text{ mA}$	—	25	100	mV	
				$5\text{ mA} \leq I_{OUT} \leq 200\text{ mA}$	—	10	50		
Output voltage	$V_{OUT}$	1	$T_j = 25^\circ\text{C}$	$7\text{ V} \leq V_{IN} \leq 20\text{ V}$ , $5\text{ mA} \leq I_{OUT} \leq 350\text{ mA}$	4.75	—	5.25	V	
Quiescent current	$I_B$	1	$T_j = 25^\circ\text{C}$	—	4.5	8.0	mA		
Quiescent current change	Line	$\Delta I_B$	1	$T_j = 25^\circ\text{C}$	8.5 V $\leq$ $V_{IN}$ $\leq$ 25.5 V, $I_{OUT} = 200\text{ mA}$	—	—	0.8	mA
	Load	$\Delta I_{BO}$				1	5 mA $\leq$ $I_{OUT}$ $\leq$ 350 mA	—	
Output noise voltage	$V_{NO}$	2	$T_j = 25^\circ\text{C}$ , 10 Hz $\leq$ f $\leq$ 100 kHz	—	50	200	$\mu\text{V}_{\text{rms}}$		
Ripple rejection	R.R.	3	f = 120 Hz, $I_{OUT} = 100\text{ mA}$ , 8 V $\leq$ $V_{IN}$ $\leq$ 18 V, $T_j = 25^\circ\text{C}$	60	67	—	dB		
Short circuit current limit	$I_{SC}$	1	$T_j = 25^\circ\text{C}$	—	960	—	mA		
Dropout voltage	$V_D$	1	$T_j = 25^\circ\text{C}$	—	1.7	—	V		
Average temperature coefficient of output voltage	$T_{CVO}$	1	$I_{OUT} = 5\text{ mA}$	—	-0.6	—	mV/ $^\circ\text{C}$		

## TA78M06F

### Electrical Characteristics

(Unless otherwise specified,  $V_{IN} = 11\text{ V}$ ,  $I_{OUT} = 350\text{ mA}$ ,  $0^\circ\text{C} \leq T_j \leq 125^\circ\text{C}$ ,  $C_{IN} = 0.33\ \mu\text{F}$ ,  $C_{OUT} = 0.1\ \mu\text{F}$ )

Characteristics	Symbol	Test Circuit	Test Condition	Min	Typ.	Max	Unit	
Output voltage	$V_{OUT}$	1	$T_j = 25^\circ\text{C}$	5.75	6.0	6.25	V	
Line regulation	Reg-line	1	$T_j = 25^\circ\text{C}$	$8\text{ V} \leq V_{IN} \leq 25\text{ V}$ , $I_{OUT} = 200\text{ mA}$	—	4	100	mV
				$9\text{ V} \leq V_{IN} \leq 25\text{ V}$ , $I_{OUT} = 200\text{ mA}$	—	2	50	
Load regulation	Reg-load	1	$T_j = 25^\circ\text{C}$	$5\text{ mA} \leq I_{OUT} \leq 500\text{ mA}$	—	25	120	mV
				$5\text{ mA} \leq I_{OUT} \leq 200\text{ mA}$	—	10	60	
Output voltage	$V_{OUT}$	1	$T_j = 25^\circ\text{C}$	5.7	—	6.3	V	
Quiescent current	$I_B$	1	$T_j = 25^\circ\text{C}$	—	4.5	8.0	mA	
Quiescent current change	Line	$\Delta I_B$	$T_j = 25^\circ\text{C}$	$9.5\text{ V} \leq V_{IN} \leq 25.5\text{ V}$ , $I_{OUT} = 200\text{ mA}$	—	—	0.8	mA
	Load	$\Delta I_{BO}$			1	$5\text{ mA} \leq I_{OUT} \leq 350\text{ mA}$	—	
Output noise voltage	$V_{NO}$	2	$T_j = 25^\circ\text{C}$ , $10\text{ Hz} \leq f \leq 100\text{ kHz}$	—	55	220	$\mu\text{V}_{rms}$	
Ripple rejection	R.R.	3	$f = 120\text{ Hz}$ , $I_{OUT} = 100\text{ mA}$ , $9\text{ V} \leq V_{IN} \leq 19\text{ V}$ , $T_j = 25^\circ\text{C}$	58	65	—	dB	
Short circuit current limit	$I_{SC}$	1	$T_j = 25^\circ\text{C}$	—	960	—	mA	
Dropout voltage	$V_D$	1	$T_j = 25^\circ\text{C}$	—	1.7	—	V	
Average temperature coefficient of output voltage	$T_{CVO}$	1	$I_{OUT} = 5\text{ mA}$	—	-0.7	—	$\text{mV}/^\circ\text{C}$	

## TA78M08F

### Electrical Characteristics

(Unless otherwise specified,  $V_{IN} = 14\text{ V}$ ,  $I_{OUT} = 350\text{ mA}$ ,  $0^\circ\text{C} \leq T_j \leq 125^\circ\text{C}$ ,  $C_{IN} = 0.33\ \mu\text{F}$ ,  $C_{OUT} = 0.1\ \mu\text{F}$ )

Characteristics		Symbol	Test Circuit	Test Condition	Min	Typ.	Max	Unit	
Output voltage		$V_{OUT}$	1	$T_j = 25^\circ\text{C}$	7.7	8.0	8.3	V	
Line regulation		Reg-line	1	$T_j = 25^\circ\text{C}$	$10.5\text{ V} \leq V_{IN} \leq 25\text{ V}$ , $I_{OUT} = 200\text{ mA}$	—	5	100	mV
					$11\text{ V} \leq V_{IN} \leq 25\text{ V}$ , $I_{OUT} = 200\text{ mA}$	—	3	50	
Load regulation		Reg-load	1	$T_j = 25^\circ\text{C}$	$5\text{ mA} \leq I_{OUT} \leq 500\text{ mA}$	—	26	160	mV
					$5\text{ mA} \leq I_{OUT} \leq 200\text{ mA}$	—	10	80	
Output voltage		$V_{OUT}$	1	$T_j = 25^\circ\text{C}$	$10.5\text{ V} \leq V_{IN} \leq 23\text{ V}$ , $5\text{ mA} \leq I_{OUT} \leq 350\text{ mA}$	7.6	—	8.4	V
Quiescent current		$I_B$	1	$T_j = 25^\circ\text{C}$	—	4.6	8.0	mA	
Quiescent current change		Line	$\Delta I_{BI}$	1	$T_j = 25^\circ\text{C}$	—	—	0.8	mA
		Load	$\Delta I_{BO}$	1					
Output noise voltage		$V_{NO}$	2	$T_j = 25^\circ\text{C}$ , $10\text{ Hz} \leq f \leq 100\text{ kHz}$	—	60	250	$\mu\text{V}_{\text{rms}}$	
Ripple rejection		R.R.	3	$f = 120\text{ Hz}$ , $I_{OUT} = 100\text{ mA}$ , $11.5\text{ V} \leq V_{IN} \leq 21.5\text{ V}$ , $T_j = 25^\circ\text{C}$	55	62	—	dB	
Short circuit current limit		$I_{SC}$	1	$T_j = 25^\circ\text{C}$	—	960	—	mA	
Dropout voltage		$V_D$	1	$T_j = 25^\circ\text{C}$	—	1.7	—	V	
Average temperature coefficient of output voltage		$T_{CVO}$	1	$I_{OUT} = 5\text{ mA}$	—	-1.0	—	$\text{mV}/^\circ\text{C}$	

## TA78M09F

### Electrical Characteristics

(Unless otherwise specified,  $V_{IN} = 15\text{ V}$ ,  $I_{OUT} = 350\text{ mA}$ ,  $0^\circ\text{C} \leq T_j \leq 125^\circ\text{C}$ ,  $C_{IN} = 0.33\ \mu\text{F}$ ,  $C_{OUT} = 0.1\ \mu\text{F}$ )

Characteristics	Symbol	Test Circuit	Test Condition	Min	Typ.	Max	Unit		
Output voltage	$V_{OUT}$	1	$T_j = 25^\circ\text{C}$	8.64	9.0	9.36	V		
Line regulation	Reg-line	1	$T_j = 25^\circ\text{C}$	$11.5\text{ V} \leq V_{IN} \leq 26\text{ V}$ , $I_{OUT} = 200\text{ mA}$	—	5	100	mV	
				$13\text{ V} \leq V_{IN} \leq 26\text{ V}$ , $I_{OUT} = 200\text{ mA}$	—	3	50		
Load regulation	Reg-load	1	$T_j = 25^\circ\text{C}$	$5\text{ mA} \leq I_{OUT} \leq 500\text{ mA}$	—	26	180	mV	
				$5\text{ mA} \leq I_{OUT} \leq 200\text{ mA}$	—	10	90		
Output voltage	$V_{OUT}$	1	$T_j = 25^\circ\text{C}$	$11.5\text{ V} \leq V_{IN} \leq 24\text{ V}$ , $5\text{ mA} \leq I_{OUT} \leq 350\text{ mA}$	8.55	—	9.45	V	
Quiescent current	$I_B$	1	$T_j = 25^\circ\text{C}$	—	4.6	8.0	mA		
Quiescent current change	Line	$\Delta I_{BI}$	1	$T_j = 25^\circ\text{C}$	12 V $\leq$ $V_{IN}$ $\leq$ 26.5 V, $I_{OUT} = 200\text{ mA}$	—	—	0.8	mA
	Load	$\Delta I_{BO}$				1	5 mA $\leq$ $I_{OUT}$ $\leq$ 350 mA	—	
Output noise voltage	$V_{NO}$	2	$T_j = 25^\circ\text{C}$ , 10 Hz $\leq$ f $\leq$ 100 kHz	—	60	270	$\mu\text{V}_{\text{rms}}$		
Ripple rejection	R.R.	3	f = 120 Hz, $I_{OUT} = 100\text{ mA}$ , 12.5 V $\leq$ $V_{IN}$ $\leq$ 22.5 V, $T_j = 25^\circ\text{C}$	54	61	—	dB		
Short circuit current limit	$I_{SC}$	1	$T_j = 25^\circ\text{C}$	—	960	—	mA		
Dropout voltage	$V_D$	1	$T_j = 25^\circ\text{C}$	—	1.7	—	V		
Average temperature coefficient of output voltage	$T_{CVO}$	1	$I_{OUT} = 5\text{ mA}$	—	-1.1	—	mV/ $^\circ\text{C}$		

## TA78M10F

### Electrical Characteristics

(Unless otherwise specified,  $V_{IN} = 16\text{ V}$ ,  $I_{OUT} = 350\text{ mA}$ ,  $0^\circ\text{C} \leq T_j \leq 125^\circ\text{C}$ ,  $C_{IN} = 0.33\ \mu\text{F}$ ,  $C_{OUT} = 0.1\ \mu\text{F}$ )

Characteristics	Symbol	Test Circuit	Test Condition	Min	Typ.	Max	Unit	
Output voltage	$V_{OUT}$	1	$T_j = 25^\circ\text{C}$	9.6	10.0	10.4	V	
Line regulation	Reg-line	1	$T_j = 25^\circ\text{C}$	$12.5\text{ V} \leq V_{IN} \leq 26\text{ V}$ , $I_{OUT} = 200\text{ mA}$	—	6	100	mV
				$14\text{ V} \leq V_{IN} \leq 26\text{ V}$ , $I_{OUT} = 200\text{ mA}$	—	3	50	
Load regulation	Reg-load	1	$T_j = 25^\circ\text{C}$	$5\text{ mA} \leq I_{OUT} \leq 500\text{ mA}$	—	26	200	mV
				$5\text{ mA} \leq I_{OUT} \leq 200\text{ mA}$	—	10	100	
Output voltage	$V_{OUT}$	1	$T_j = 25^\circ\text{C}$	9.5	—	10.5	V	
Quiescent current	$I_B$	1	$T_j = 25^\circ\text{C}$	—	4.7	8.0	mA	
Quiescent current change	Line	$\Delta I_{BI}$	$T_j = 25^\circ\text{C}$	$13\text{ V} \leq V_{IN} \leq 26.5\text{ V}$ , $I_{OUT} = 200\text{ mA}$	—	—	0.8	mA
	Load	$\Delta I_{BO}$			1	$5\text{ mA} \leq I_{OUT} \leq 350\text{ mA}$	—	
Output noise voltage	$V_{NO}$	2	$T_j = 25^\circ\text{C}$ , $10\text{ Hz} \leq f \leq 100\text{ kHz}$	—	65	280	$\mu\text{V}_{\text{rms}}$	
Ripple rejection	R.R.	3	$f = 120\text{ Hz}$ , $I_{OUT} = 100\text{ mA}$ , $13.5\text{ V} \leq V_{IN} \leq 23.5\text{ V}$ , $T_j = 25^\circ\text{C}$	52	59	—	dB	
Short circuit current limit	$I_{SC}$	1	$T_j = 25^\circ\text{C}$	—	960	—	mA	
Dropout voltage	$V_D$	1	$T_j = 25^\circ\text{C}$	—	1.7	—	V	
Average temperature coefficient of output voltage	$T_{CVO}$	1	$I_{OUT} = 5\text{ mA}$	—	-1.3	—	$\text{mV}/^\circ\text{C}$	

## TA78M12F

### Electrical Characteristics

(Unless otherwise specified,  $V_{IN} = 19\text{ V}$ ,  $I_{OUT} = 350\text{ mA}$ ,  $0^\circ\text{C} \leq T_j \leq 125^\circ\text{C}$ ,  $C_{IN} = 0.33\ \mu\text{F}$ ,  $C_{OUT} = 0.1\ \mu\text{F}$ )

Characteristics		Symbol	Test Circuit	Test Condition	Min	Typ.	Max	Unit	
Output voltage		$V_{OUT}$	1	$T_j = 25^\circ\text{C}$	11.5	12.0	12.5	V	
Line regulation		Reg-line	1	$T_j = 25^\circ\text{C}$	$14.5\text{ V} \leq V_{IN} \leq 30\text{ V}$ , $I_{OUT} = 200\text{ mA}$	—	7	100	mV
					$16\text{ V} \leq V_{IN} \leq 30\text{ V}$ , $I_{OUT} = 200\text{ mA}$	—	3	50	
Load regulation		Reg-load	1	$T_j = 25^\circ\text{C}$	$5\text{ mA} \leq I_{OUT} \leq 500\text{ mA}$	—	27	240	mV
					$5\text{ mA} \leq I_{OUT} \leq 200\text{ mA}$	—	10	120	
Output voltage		$V_{OUT}$	1	$T_j = 25^\circ\text{C}$	$14.5\text{ V} \leq V_{IN} \leq 27\text{ V}$ , $5\text{ mA} \leq I_{OUT} \leq 350\text{ mA}$	11.4	—	12.6	V
Quiescent current		$I_B$	1	$T_j = 25^\circ\text{C}$	—	4.8	8.0	mA	
Quiescent current change		Line	$\Delta I_{BI}$	1	$T_j = 25^\circ\text{C}$	—	—	0.8	mA
		Load	$\Delta I_{BO}$						
Output noise voltage		$V_{NO}$	2	$T_j = 25^\circ\text{C}$ , $10\text{ Hz} \leq f \leq 100\text{ kHz}$	—	70	300	$\mu\text{V}_{\text{rms}}$	
Ripple rejection		R.R.	3	$f = 120\text{ Hz}$ , $I_{OUT} = 100\text{ mA}$ , $15\text{ V} \leq V_{IN} \leq 25\text{ V}$ , $T_j = 25^\circ\text{C}$	50	57	—	dB	
Short circuit current limit		$I_{SC}$	1	$T_j = 25^\circ\text{C}$	—	960	—	mA	
Dropout voltage		$V_D$	1	$T_j = 25^\circ\text{C}$	—	1.7	—	V	
Average temperature coefficient of output voltage		$T_{CVO}$	1	$I_{OUT} = 5\text{ mA}$	—	-1.6	—	$\text{mV}/^\circ\text{C}$	

## TA78M15F

### Electrical Characteristics

(Unless otherwise specified,  $V_{IN} = 23\text{ V}$ ,  $I_{OUT} = 350\text{ mA}$ ,  $0^\circ\text{C} \leq T_j \leq 125^\circ\text{C}$ ,  $C_{IN} = 0.33\ \mu\text{F}$ ,  $C_{OUT} = 0.1\ \mu\text{F}$ )

Characteristics	Symbol	Test Circuit	Test Condition	Min	Typ.	Max	Unit		
Output voltage	$V_{OUT}$	1	$T_j = 25^\circ\text{C}$	14.4	15.0	15.6	V		
Line regulation	Reg-line	1	$T_j = 25^\circ\text{C}$	$17.5\text{ V} \leq V_{IN} \leq 30\text{ V}$ , $I_{OUT} = 200\text{ mA}$	—	8	100	mV	
				$20\text{ V} \leq V_{IN} \leq 30\text{ V}$ , $I_{OUT} = 200\text{ mA}$	—	4	50		
Load regulation	Reg-load	1	$T_j = 25^\circ\text{C}$	$5\text{ mA} \leq I_{OUT} \leq 500\text{ mA}$	—	27	300	mV	
				$5\text{ mA} \leq I_{OUT} \leq 200\text{ mA}$	—	10	150		
Output voltage	$V_{OUT}$	1	$T_j = 25^\circ\text{C}$	$17.5\text{ V} \leq V_{IN} \leq 30\text{ V}$ , $5\text{ mA} \leq I_{OUT} \leq 350\text{ mA}$	14.25	—	15.75	V	
Quiescent current	$I_B$	1	$T_j = 25^\circ\text{C}$	—	4.8	8.0	mA		
Quiescent current change	Line	$\Delta I_{BI}$	1	$T_j = 25^\circ\text{C}$	$18\text{ V} \leq V_{IN} \leq 30.5\text{ V}$ , $I_{OUT} = 200\text{ mA}$	—	—	0.8	mA
	Load	$\Delta I_{BO}$				1	$5\text{ mA} \leq I_{OUT} \leq 350\text{ mA}$	—	
Output noise voltage	$V_{NO}$	2	$T_j = 25^\circ\text{C}$ , $10\text{ Hz} \leq f \leq 100\text{ kHz}$	—	80	450	$\mu\text{V}_{\text{rms}}$		
Ripple rejection	R.R.	3	$f = 120\text{ Hz}$ , $I_{OUT} = 100\text{ mA}$ , $18.5\text{ V} \leq V_{IN} \leq 28.5\text{ V}$ , $T_j = 25^\circ\text{C}$	48	55	—	dB		
Short circuit current limit	$I_{SC}$	1	$T_j = 25^\circ\text{C}$	—	960	—	mA		
Dropout voltage	$V_D$	1	$T_j = 25^\circ\text{C}$	—	1.7	—	V		
Average temperature coefficient of output voltage	$T_{CVO}$	1	$I_{OUT} = 5\text{ mA}$	—	-2.0	—	$\text{mV}/^\circ\text{C}$		

## TA78M18F

### Electrical Characteristics

(Unless otherwise specified,  $V_{IN} = 27\text{ V}$ ,  $I_{OUT} = 350\text{ mA}$ ,  $0^\circ\text{C} \leq T_j \leq 125^\circ\text{C}$ ,  $C_{IN} = 0.33\ \mu\text{F}$ ,  $C_{OUT} = 0.1\ \mu\text{F}$ )

Characteristics		Symbol	Test Circuit	Test Condition	Min	Typ.	Max	Unit
Output voltage		$V_{OUT}$	1	$T_j = 25^\circ\text{C}$	17.3	18.0	18.7	V
Line regulation	Reg-line	1	$T_j = 25^\circ\text{C}$	$21\text{ V} \leq V_{IN} \leq 33\text{ V}$ , $I_{OUT} = 200\text{ mA}$	—	9	100	mV
				$24\text{ V} \leq V_{IN} \leq 33\text{ V}$ , $I_{OUT} = 200\text{ mA}$	—	5	50	
Load regulation	Reg-load	1	$T_j = 25^\circ\text{C}$	$5\text{ mA} \leq I_{OUT} \leq 500\text{ mA}$	—	28	360	mV
				$5\text{ mA} \leq I_{OUT} \leq 200\text{ mA}$	—	10	180	
Output voltage		$V_{OUT}$	1	$T_j = 25^\circ\text{C}$ $21\text{ V} \leq V_{IN} \leq 33\text{ V}$ , $5\text{ mA} \leq I_{OUT} \leq 350\text{ mA}$	17.1	—	18.9	V
Quiescent current		$I_B$	1	$T_j = 25^\circ\text{C}$	—	4.8	8.0	mA
Quiescent current change	Line	$\Delta I_{BI}$	1	$T_j = 25^\circ\text{C}$ $21.5\text{ V} \leq V_{IN} \leq 33.5\text{ V}$ , $I_{OUT} = 200\text{ mA}$	—	—	0.8	mA
	Load	$\Delta I_{BO}$	1		$5\text{ mA} \leq I_{OUT} \leq 350\text{ mA}$	—	—	
Output noise voltage		$V_{NO}$	2	$T_j = 25^\circ\text{C}$ , $10\text{ Hz} \leq f \leq 100\text{ kHz}$	—	90	490	$\mu\text{V}_{\text{rms}}$
Ripple rejection		R.R.	3	$f = 120\text{ Hz}$ , $I_{OUT} = 100\text{ mA}$ , $22\text{ V} \leq V_{IN} \leq 32\text{ V}$ , $T_j = 25^\circ\text{C}$	46	53	—	dB
Short circuit current limit		$I_{SC}$	1	$T_j = 25^\circ\text{C}$	—	960	—	mA
Dropout voltage		$V_D$	1	$T_j = 25^\circ\text{C}$	—	1.7	—	V
Average temperature coefficient of output voltage		$T_{CVO}$	1	$I_{OUT} = 5\text{ mA}$	—	-2.5	—	$\text{mV}/^\circ\text{C}$

## TA78M20F

### Electrical Characteristics

(Unless otherwise specified,  $V_{IN} = 29\text{ V}$ ,  $I_{OUT} = 350\text{ mA}$ ,  $0^\circ\text{C} \leq T_j \leq 125^\circ\text{C}$ ,  $C_{IN} = 0.33\ \mu\text{F}$ ,  $C_{OUT} = 0.1\ \mu\text{F}$ )

Characteristics	Symbol	Test Circuit	Test Condition	Min	Typ.	Max	Unit		
Output voltage	$V_{OUT}$	1	$T_j = 25^\circ\text{C}$	19.2	20.0	20.8	V		
Line regulation	Reg-line	1	$T_j = 25^\circ\text{C}$	$23\text{ V} \leq V_{IN} \leq 35\text{ V}$ , $I_{OUT} = 200\text{ mA}$	—	10	100	mV	
				$24\text{ V} \leq V_{IN} \leq 35\text{ V}$ , $I_{OUT} = 200\text{ mA}$	—	6	50		
Load regulation	Reg-load	1	$T_j = 25^\circ\text{C}$	$5\text{ mA} \leq I_{OUT} \leq 500\text{ mA}$	—	28	400	mV	
				$5\text{ mA} \leq I_{OUT} \leq 200\text{ mA}$	—	10	200		
Output voltage	$V_{OUT}$	1	$T_j = 25^\circ\text{C}$	$23\text{ V} \leq V_{IN} \leq 35\text{ V}$ , $5\text{ mA} \leq I_{OUT} \leq 350\text{ mA}$	19.0	—	21.0	V	
Quiescent current	$I_B$	1	$T_j = 25^\circ\text{C}$	—	4.9	8.0	mA		
Quiescent current change	Line	$\Delta I_{BI}$	1	$T_j = 25^\circ\text{C}$	$23.5\text{ V} \leq V_{IN} \leq 35.5\text{ V}$ , $I_{OUT} = 200\text{ mA}$	—	—	0.8	mA
	Load	$\Delta I_{BO}$				1	$5\text{ mA} \leq I_{OUT} \leq 350\text{ mA}$	—	
Output noise voltage	$V_{NO}$	2	$T_j = 25^\circ\text{C}$ , $10\text{ Hz} \leq f \leq 100\text{ kHz}$	—	95	540	$\mu\text{V}_{\text{rms}}$		
Ripple rejection	R.R.	3	$f = 120\text{ Hz}$ , $I_{OUT} = 100\text{ mA}$ , $24\text{ V} \leq V_{IN} \leq 34\text{ V}$ , $T_j = 25^\circ\text{C}$	46	53	—	dB		
Short circuit current limit	$I_{SC}$	1	$T_j = 25^\circ\text{C}$	—	960	—	mA		
Dropout voltage	$V_D$	1	$T_j = 25^\circ\text{C}$	—	1.7	—	V		
Average temperature coefficient of output voltage	$T_{CVO}$	1	$I_{OUT} = 5\text{ mA}$	—	-3.0	—	$\text{mV}/^\circ\text{C}$		

## TA78M24F

### Electrical Characteristics

(Unless otherwise specified,  $V_{IN} = 33\text{ V}$ ,  $I_{OUT} = 350\text{ mA}$ ,  $0^\circ\text{C} \leq T_j \leq 125^\circ\text{C}$ ,  $C_{IN} = 0.33\ \mu\text{F}$ ,  $C_{OUT} = 0.1\ \mu\text{F}$ )

Characteristics		Symbol	Test Circuit	Test Condition	Min	Typ.	Max	Unit		
Output voltage		$V_{OUT}$	1	$T_j = 25^\circ\text{C}$	23.0	24.0	25.0	V		
Line regulation		Reg-line	1	$T_j = 25^\circ\text{C}$	$27\text{ V} \leq V_{IN} \leq 38\text{ V}$ , $I_{OUT} = 200\text{ mA}$	—	12	100	mV	
					$28\text{ V} \leq V_{IN} \leq 38\text{ V}$ , $I_{OUT} = 200\text{ mA}$	—	7	50		
Load regulation		Reg-load	1	$T_j = 25^\circ\text{C}$	$5\text{ mA} \leq I_{OUT} \leq 500\text{ mA}$	—	30	480	mV	
					$5\text{ mA} \leq I_{OUT} \leq 200\text{ mA}$	—	10	240		
Output voltage		$V_{OUT}$	1	$T_j = 25^\circ\text{C}$	$27\text{ V} \leq V_{IN} \leq 38\text{ V}$ , $5\text{ mA} \leq I_{OUT} \leq 350\text{ mA}$	22.8	—	25.2	V	
Quiescent current		$I_B$	1	$T_j = 25^\circ\text{C}$	—	5.0	8.0	mA		
Quiescent current change		Line	$\Delta I_{BI}$	1	$T_j = 25^\circ\text{C}$	$27.5\text{ V} \leq V_{IN} \leq 38.5\text{ V}$ , $I_{OUT} = 200\text{ mA}$	—	—	0.8	mA
		Load	$\Delta I_{BO}$				1	$5\text{ mA} \leq I_{OUT} \leq 350\text{ mA}$	—	
Output noise voltage		$V_{NO}$	2	$T_j = 25^\circ\text{C}$ , $10\text{ Hz} \leq f \leq 100\text{ kHz}$	—	115	650	$\mu\text{V}_{\text{rms}}$		
Ripple rejection		R.R.	3	$f = 120\text{ Hz}$ , $I_{OUT} = 100\text{ mA}$ , $28\text{ V} \leq V_{IN} \leq 38\text{ V}$ , $T_j = 25^\circ\text{C}$	46	53	—	dB		
Short circuit current limit		$I_{SC}$	1	$T_j = 25^\circ\text{C}$	—	960	—	mA		
Dropout voltage		$V_D$	1	$T_j = 25^\circ\text{C}$	—	1.7	—	V		
Average temperature coefficient of output voltage		$T_{CVO}$	1	$I_{OUT} = 5\text{ mA}$	—	-3.5	—	$\text{mV}/^\circ\text{C}$		

## Test Circuit 1 / Standard Application

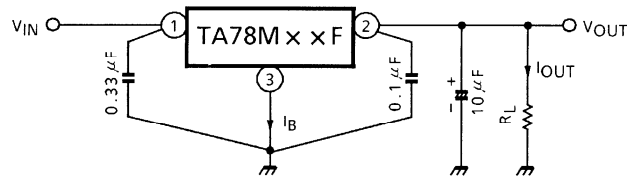

## Test Circuit 2

$V_{NO}$

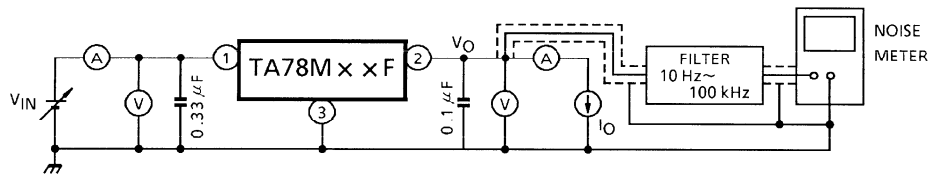

## Test Circuit 3

R.R.

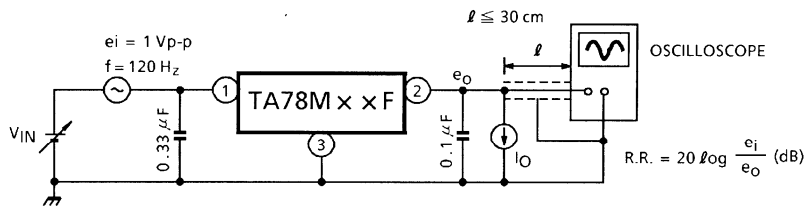

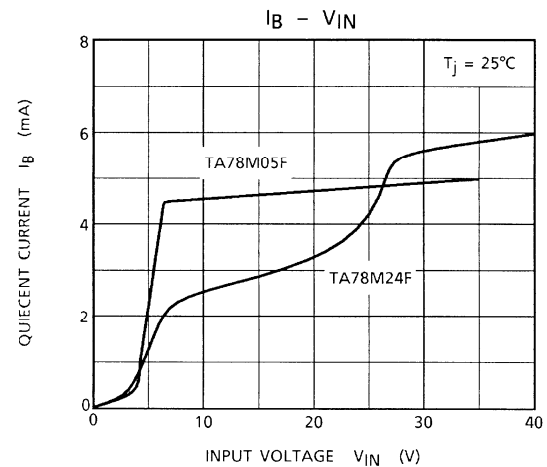
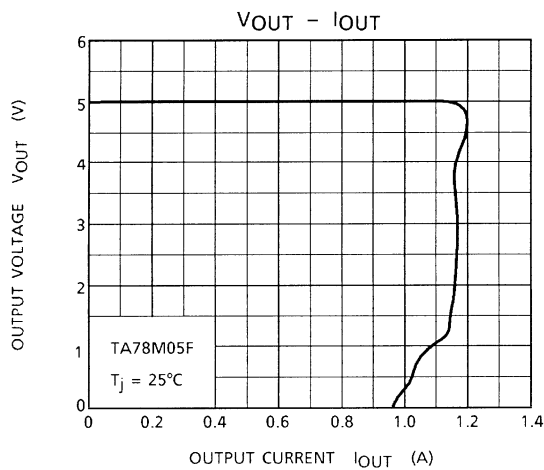
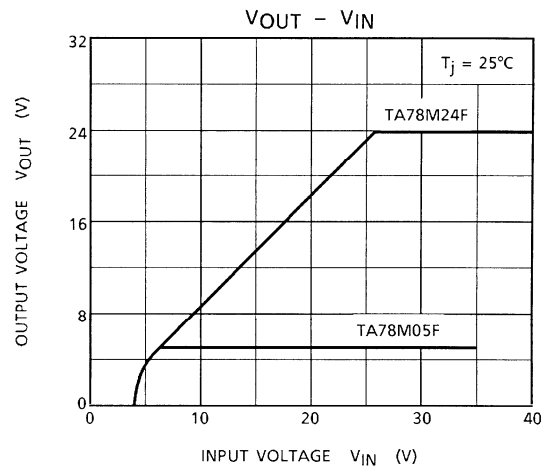
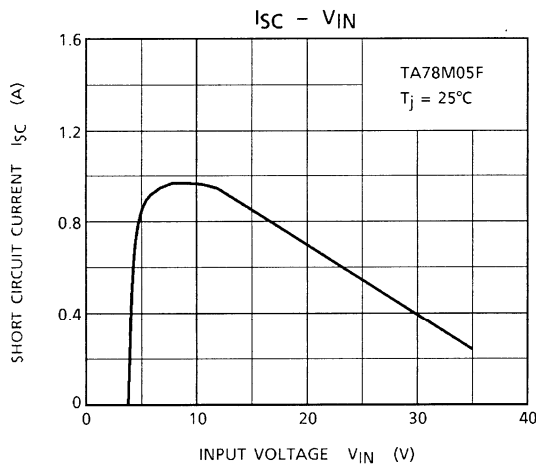
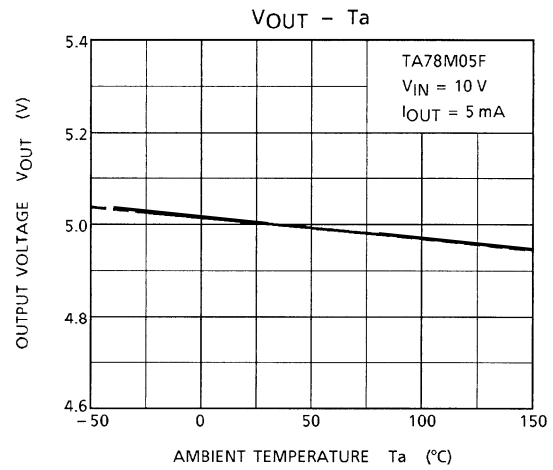
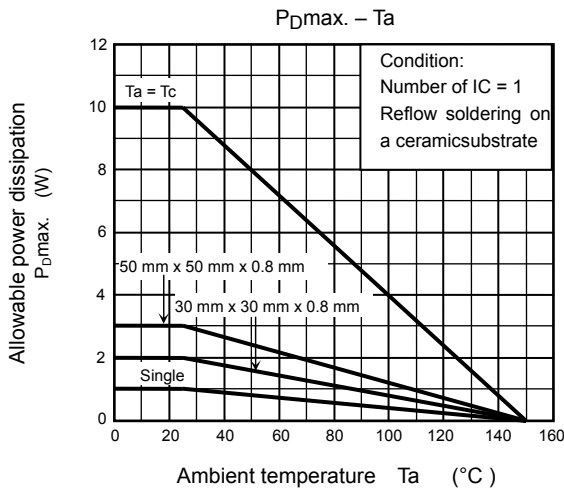

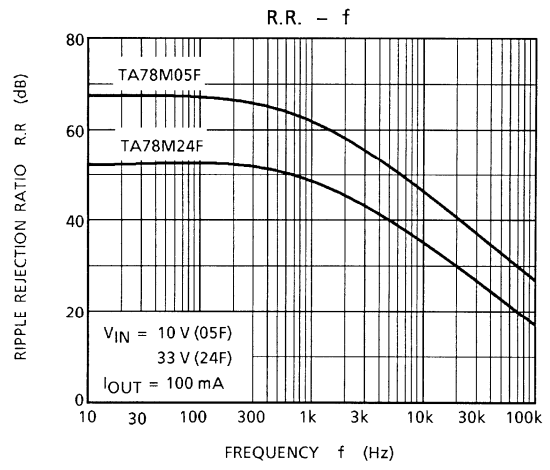
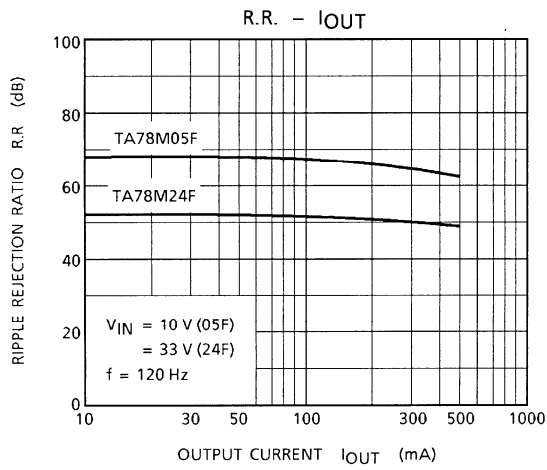
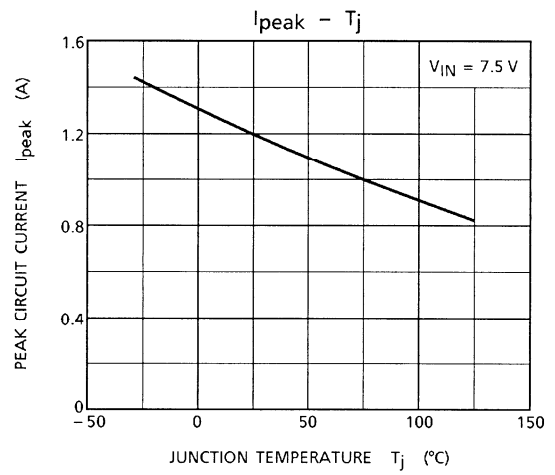
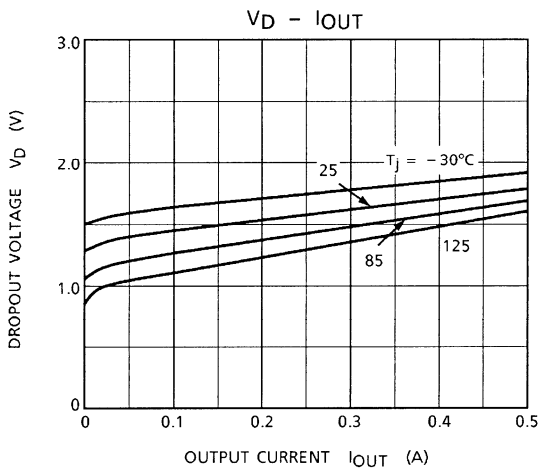

**Usage Precautions**

- (1) In regard to GND, be careful not to apply a negative voltage to the input/output terminal.
- (2) If a surge voltage exceeding the absolute maximum rating is applied to the input terminal or if a voltage in excess of the input terminal voltage is applied to the output terminal, the circuit may be destroyed.

Particular care is necessary in the case of the latter.

Circuit destruction may also occur if the input terminal shorts to GND in a state of normal operation, causing the output terminal voltage to exceed the input voltage (GND potential) and the electrical charge of the chemical capacitor connected to the output terminal to flow into the input side.

Where these risks exist, take steps such as connecting Zener and general silicon diodes to the circuit, as shown in the figure below.

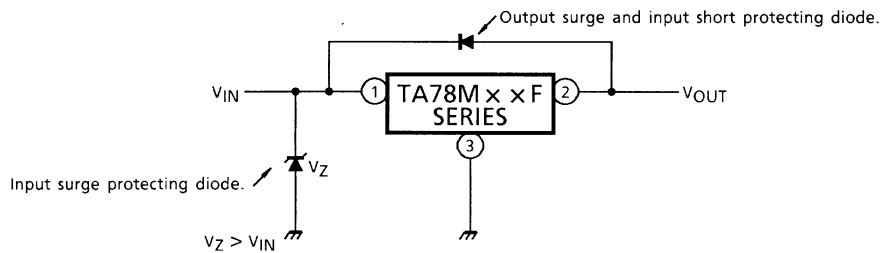

- (3) When the input voltage is too high, the power dissipation of the three-terminal regulator, which is a series regulator, increases, causing the junction temperature to rise. In such a case, it is recommended to reduce the power dissipation, and hence the junction temperature, by inserting a power-limiting resistor  $R_{SD}$  in the input terminal.

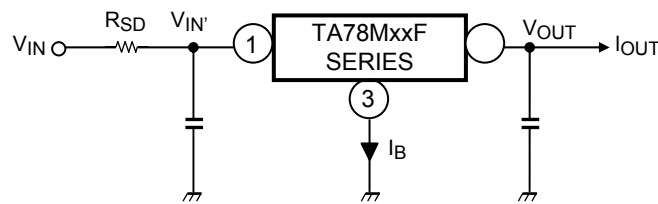

The power dissipation  $P_D$  of the IC is expressed in the following equation.

$$P_D = (V_{IN}' - V_{OUT}) \cdot I_{OUT} + V_{IN}' \cdot I_B$$

Reducing  $V_{IN}'$  below the lowest voltage necessary for the IC will cause ripple, deterioration in output regulation and, in certain circumstances, parasitic oscillation.

To determine the resistance value of  $R_{SD}$ , design with a margin, referring to the following equation.

$$R_{SD} < \frac{V_{IN} - V_{IN}'}{I_{OUT} + I_B}$$

- (4) Be sure to connect a capacitor near the input terminal and output terminal between both terminals and GND. The capacitances should be determined experimentally because they depend on printed circuit board patterns. In particular, adequate investigation should be made to ensure there is no problem even in high or low temperatures.
- (5) The molded plastic portion of this unit, measuring 5.5 mm (L) by 6.5 mm (W) by 2.3 mm (T), is more compact compared to its equivalent TO-220. The collector fin extends directly out of the main body and can be soldered directly to the ceramic circuit board for significant increase in collector power dissipation. To obtain high reliability on the heat sink design of a regulator IC, it is generally required to derate more than 20% of maximum junction temperature ( $T_j \text{ max}$ ). Further, full consideration should be given to the installation of the IC on a heat sink.

- Low voltage

Do not apply voltage to the Product that is lower than the minimum operating voltage, or the Product's protective functions will not operate properly and the Product may be permanently damaged.

- Overcurrent Protection

The overcurrent protection circuits in the Product are designed to temporarily protect Product from minor overcurrent of brief duration. When the overcurrent protective function in the Product activates, immediately cease application of overcurrent to Product. Improper usage of Product, such as application of current to Product exceeding the absolute maximum ratings, could cause the overcurrent protection circuit not to operate properly and/or damage Product permanently even before the protection circuit starts to operate.

- Overheating Protection

The thermal shutdown circuits in the Product are designed to temporarily protect Product from minor overheating of brief duration. When the overheating protective function in the Product activates, immediately correct the overheating situation. Improper usage of Product, such as the application of heat to Product exceeding the absolute maximum ratings, could cause the overheating protection circuit not to operate properly and/or damage Product permanently even before the protection circuit starts to operate.

## Package Dimensions

HSOP3-P-2.30D

Unit: mm

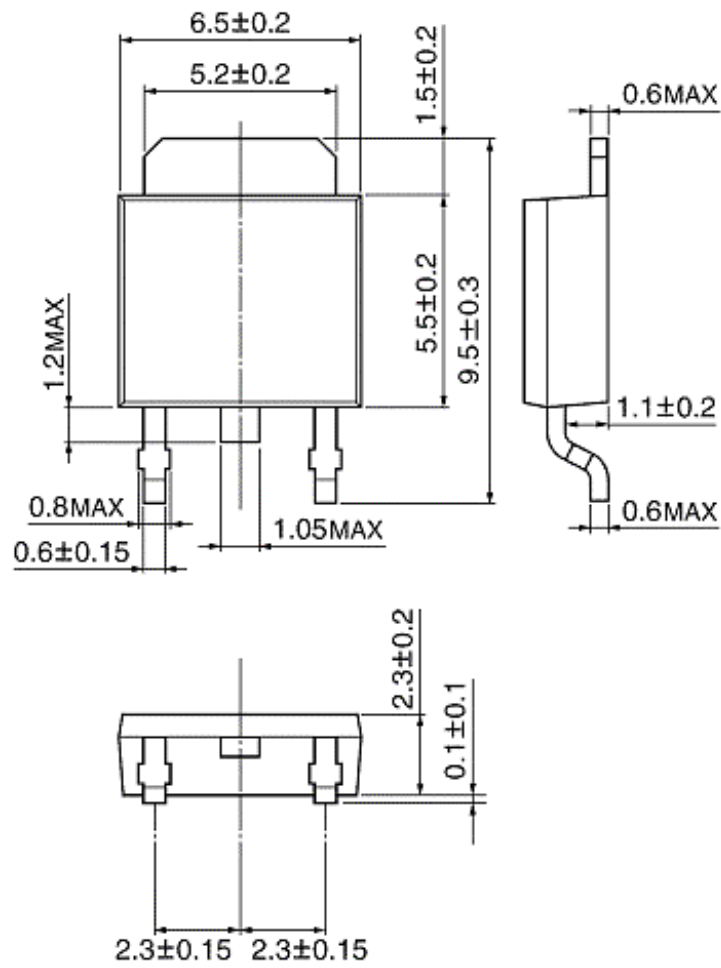

Weight: 0.36 g (typ.)

**RESTRICTIONS ON PRODUCT USE**

- Toshiba Corporation, and its subsidiaries and affiliates (collectively "TOSHIBA"), reserve the right to make changes to the information in this document, and related hardware, software and systems (collectively "Product") without notice.
- This document and any information herein may not be reproduced without prior written permission from TOSHIBA. Even with TOSHIBA's written permission, reproduction is permissible only if reproduction is without alteration/omission.
- Though TOSHIBA works continually to improve Product's quality and reliability, Product can malfunction or fail. Customers are responsible for complying with safety standards and for providing adequate designs and safeguards for their hardware, software and systems which minimize risk and avoid situations in which a malfunction or failure of Product could cause loss of human life, bodily injury or damage to property, including data loss or corruption. Before creating and producing designs and using, customers must also refer to and comply with (a) the latest versions of all relevant TOSHIBA information, including without limitation, this document, the specifications, the data sheets and application notes for Product and the precautions and conditions set forth in the "TOSHIBA Semiconductor Reliability Handbook" and (b) the instructions for the application that Product will be used with or for. Customers are solely responsible for all aspects of their own product design or applications, including but not limited to (a) determining the appropriateness of the use of this Product in such design or applications; (b) evaluating and determining the applicability of any information contained in this document, or in charts, diagrams, programs, algorithms, sample application circuits, or any other referenced documents; and (c) validating all operating parameters for such designs and applications. **TOSHIBA ASSUMES NO LIABILITY FOR CUSTOMERS' PRODUCT DESIGN OR APPLICATIONS.**
- Product is intended for use in general electronics applications (e.g., computers, personal equipment, office equipment, measuring equipment, industrial robots and home electronics appliances) or for specific applications as expressly stated in this document. Product is neither intended nor warranted for use in equipment or systems that require extraordinarily high levels of quality and/or reliability and/or a malfunction or failure of which may cause loss of human life, bodily injury, serious property damage or serious public impact ("Unintended Use"). Unintended Use includes, without limitation, equipment used in nuclear facilities, equipment used in the aerospace industry, medical equipment, equipment used for automobiles, trains, ships and other transportation, traffic signaling equipment, equipment used to control combustions or explosions, safety devices, elevators and escalators, devices related to electric power, and equipment used in finance-related fields. Do not use Product for Unintended Use unless specifically permitted in this document.
- Do not disassemble, analyze, reverse-engineer, alter, modify, translate or copy Product, whether in whole or in part.
- Product shall not be used for or incorporated into any products or systems whose manufacture, use, or sale is prohibited under any applicable laws or regulations.
- The information contained herein is presented only as guidance for Product use. No responsibility is assumed by TOSHIBA for any infringement of patents or any other intellectual property rights of third parties that may result from the use of Product. No license to any intellectual property right is granted by this document, whether express or implied, by estoppel or otherwise.
- **ABSENT A WRITTEN SIGNED AGREEMENT, EXCEPT AS PROVIDED IN THE RELEVANT TERMS AND CONDITIONS OF SALE FOR PRODUCT, AND TO THE MAXIMUM EXTENT ALLOWABLE BY LAW, TOSHIBA (1) ASSUMES NO LIABILITY WHATSOEVER, INCLUDING WITHOUT LIMITATION, INDIRECT, CONSEQUENTIAL, SPECIAL, OR INCIDENTAL DAMAGES OR LOSS, INCLUDING WITHOUT LIMITATION, LOSS OF PROFITS, LOSS OF OPPORTUNITIES, BUSINESS INTERRUPTION AND LOSS OF DATA, AND (2) DISCLAIMS ANY AND ALL EXPRESS OR IMPLIED WARRANTIES AND CONDITIONS RELATED TO SALE, USE OF PRODUCT, OR INFORMATION, INCLUDING WARRANTIES OR CONDITIONS OF MERCHANTABILITY, FITNESS FOR A PARTICULAR PURPOSE, ACCURACY OF INFORMATION, OR NONINFRINGEMENT.**
- Do not use or otherwise make available Product or related software or technology for any military purposes, including without limitation, for the design, development, use, stockpiling or manufacturing of nuclear, chemical, or biological weapons or missile technology products (mass destruction weapons). Product and related software and technology may be controlled under the Japanese Foreign Exchange and Foreign Trade Law and the U.S. Export Administration Regulations. Export and re-export of Product or related software or technology are strictly prohibited except in compliance with all applicable export laws and regulations.
- Please contact your TOSHIBA sales representative for details as to environmental matters such as the RoHS compatibility of Product. Please use Product in compliance with all applicable laws and regulations that regulate the inclusion or use of controlled substances, including without limitation, the EU RoHS Directive. TOSHIBA assumes no liability for damages or losses occurring as a result of noncompliance with applicable laws and regulations.