

## General Description

The AAT3152 is a low noise, constant frequency charge pump DC/DC converter that uses a tri-mode load switch (1X), fractional (1.5X), and doubling (2X) conversion to maximize efficiency for white LED applications. The AAT3152 is capable of driving four-channel LEDs from a 2.7V to 5.5V input. The current sinks may be operated individually or in parallel for driving higher-current LEDs. A low external parts count (two 1µF flying capacitors and two small 1µF capacitors at  $V_{IN}$  and  $V_{OUT}$ ) makes this part ideally suited for small, battery-powered applications.

AnalogicTech's S<sup>2</sup>Cwire™ (Simple Serial Control™) serial digital input is used to enable, disable, and set current for each LED with eight settings (20mA down to 50µA) including main/sub-display group control. The AAT3152 consumes extremely low current internally (50µA typical) at light load for optimized efficiency.

Each output of the AAT3152 is equipped with built-in protection for  $V_{OUT}$  short-circuit and auto-disable for load short-circuit conditions. Built-in soft-start circuitry prevents excessive inrush current during start-up. A low current shutdown feature disconnects the load from  $V_{IN}$  and reduces quiescent current to less than 1µA.

The AAT3152 is available in a Pb-free, space-saving, thermally-enhanced 12-pin 3x3mm TDFN package.

## Features

- $V_{IN}$  Range: 2.7V to 5.5V
- Fully Programmable Current with Single Wire
  - Eight-Step Current: 20mA to 50µA
  - Individual Main-Sub Group Control
  - Low  $I_Q$  (50µA) at Light Load
- Tri-Mode 1X, 1.5X, and 2X Charge Pump for Maximum Efficiency and  $V_F$  Coverage
- Drives 1-4 Channels of LEDs
- No Inductors, Low Noise Operation
- 1MHz Constant Switching Frequency
- Small Application Circuit
- Built-In Thermal Protection
- Built-In Auto-Disable for Short-Circuit
- Automatic Soft Start
- $I_Q < 1\mu A$  in Shutdown
- Thermally-Enhanced 3x3mm 12-Pin TDFN Package

## Applications

- Color (RGB) Lighting
- Programmable Current Sinks
- White LED Backlighting
- White Photo Flash for Digital Still Cameras

## Typical Application

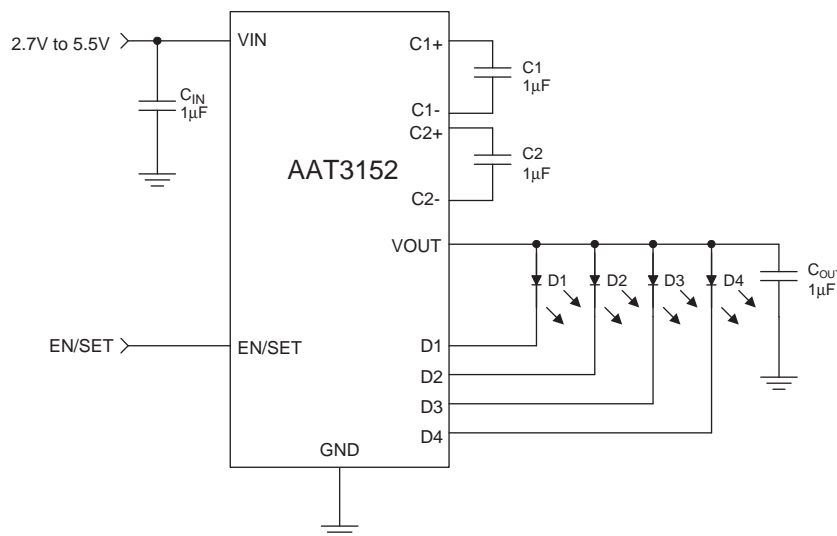

## Pin Descriptions

Pin #	Symbol	Function
1	D4	Current sink input # 4.
2	EN/SET	S <sup>2</sup> Cwire serial interface control pin.
3	C1+	Flying capacitor 1 positive terminal. Connect a 1μF capacitor between C1+ and C1-.
4	C1-	Flying capacitor 1 negative terminal.
5	VOUT	Charge pump output to drive load circuit. Requires 1μF capacitor connected between this pin and ground.
6	C2+	Flying capacitor 2 positive terminal. Connect a 1μF capacitor between C2+ and C2-.
7	C2-	Flying capacitor 2 negative terminal.
8	VIN	Input power supply. Requires 1μF capacitor connected between this pin and ground.
9	GND	Ground.
10	D1	Current sink input # 1.
11	D2	Current sink input # 2.
12	D3	Current sink input # 3.
EP		Exposed paddle (bottom); connect to GND directly beneath package.

## Pin Configuration

**TDFN33-12  
(Top View)**

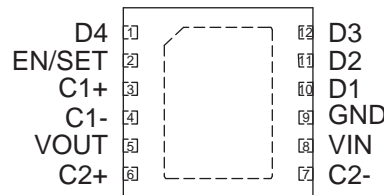

**ChargePump™ High Efficiency 1X/1.5X/2X Charge Pump for White LED Applications**
**Absolute Maximum Ratings<sup>1</sup>**

Symbol	Description	Value	Units
$V_{IN}$	Input Voltage	-0.3 to 6	V
$V_{EN/SET}$	EN/SET to GND Voltage	-0.3 to $V_{IN} + 0.3$	V
$I_{OUT}^2$	Maximum DC Output Current	150	mA
$T_J$	Operating Junction Temperature Range	-40 to 150	°C
$T_{LEAD}$	Maximum Soldering Temperature (at leads, 10 sec.)	300	°C

**Thermal Information<sup>3</sup>**

Symbol	Description	Value	Units
$P_D$	Maximum Power Dissipation <sup>4</sup>	2.0	W
$\theta_{JA}$	Maximum Thermal Resistance	50	°C/W

1. Stresses above those listed in Absolute Maximum Ratings may cause permanent damage to the device. Functional operation at conditions other than the operating conditions specified is not implied. Only one Absolute Maximum Rating should be applied at any one time.

2. Based on long-term current density limitation.

3. Mounted on an FR4 board.

4. Derate 20mW/°C above 25°C.

**ChargePump™ High Efficiency 1X/1.5X/2X Charge Pump for White LED Applications**
**Electrical Characteristics<sup>1</sup>**
 $C_{IN} = C_{OUT} = C_1 = C_2 = 1.0\mu\text{F}$ ;  $T_A = -40^\circ\text{C}$  to  $+85^\circ\text{C}$ , unless otherwise noted. Typical values are  $T_A = 25^\circ\text{C}$ ,  $V_{IN} = 3.6\text{V}$ .

Symbol	Description	Conditions	Min	Typ	Max	Units
<b>Input Power Supply</b>						
$V_{IN}$	Operation Range		2.7		5.5	V
$I_{CC}$	Operating Current	1X Mode, $3.0 \leq V_{IN} \leq 5.5$ , Active, No Load Current		0.3	1	mA
		1.5X Mode, $3.0 \leq V_{IN} \leq 5.5$ , Active, No Load Current		1	3	
		2X Mode, $3.0 \leq V_{IN} \leq 5.5$ , Active, No Load Current		1.5	3	
		50 $\mu\text{A}$ Setting, 1X Mode		50		$\mu\text{A}$
$I_{SHDN}$	Shutdown Current	EN/SET = 0			1	$\mu\text{A}$
$I_{DX}$	$I_{SINK}$ Average Current Accuracy	$I_{SET} = 20\text{mA}$ , $T_A = 25^\circ\text{C}$	-10		10	%
$I_{(D-Match)}$	Current Matching Between Any Two Current Sink Inputs <sup>2, 3</sup>	$V_F: D1:D4 = 3.6\text{V}$		0.5		%
$V_{TH}$	1X to 1.5X or 1.5X to 2X Transition Threshold at Any Current Sink Pin			150		mV
<b>Charge Pump Section</b>						
$T_{SS}$	Soft-Start Time			100		$\mu\text{s}$
$F_{CLK}$	Clock Frequency			1000		kHz
<b>EN/ SET</b>						
$V_{EN(L)}$	Enable Threshold Low				0.4	V
$V_{EN(H)}$	Enable Threshold High		1.4			V
$T_{EN/SET LO}$	EN/SET Low Time		0.3		75	$\mu\text{s}$
$T_{EN/SET HI MIN}$	Minimum EN/SET High Time			50		ns
$T_{EN/SET HI MAX}$	Maximum EN/SET High Time				75	$\mu\text{s}$
$T_{OFF}$	EN/SET Off Timeout				500	$\mu\text{s}$
$T_{LAT}$	EN/SET Latch Timeout				500	$\mu\text{s}$
$I_{EN/SET}$	EN/SET Input Leakage		-1		1	$\mu\text{A}$

1. The AAT3152 is guaranteed to meet performance specifications over the  $-40^\circ\text{C}$  to  $+85^\circ\text{C}$  operating temperature range and is assured by design, characterization, and correlation with statistical process controls.

2. Current matching is defined as the deviation of any sink current at  $I_{OUT} = 20\text{mA}$  and  $2\text{mA}$ .

3. Specification applies only to the tri-mode charge pump.

## Typical Characteristics

Efficiency vs. Supply Voltage

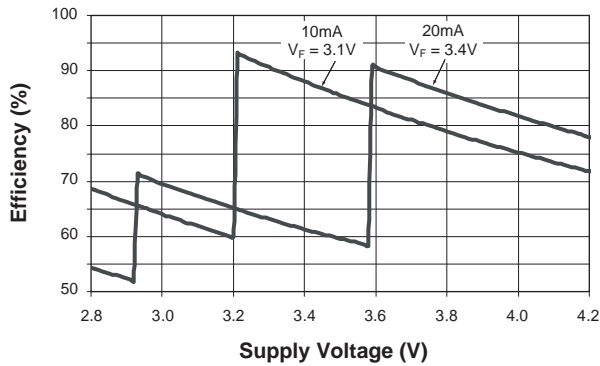

Turn-On to 1X Mode  
( $V_{IN} = 4.2V$ ; 20mA Load)

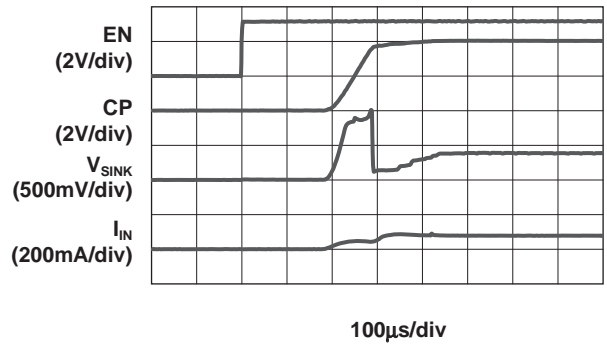

Turn-On to 1.5X Mode  
( $V_{IN} = 3.5V$ ; 20mA Load)

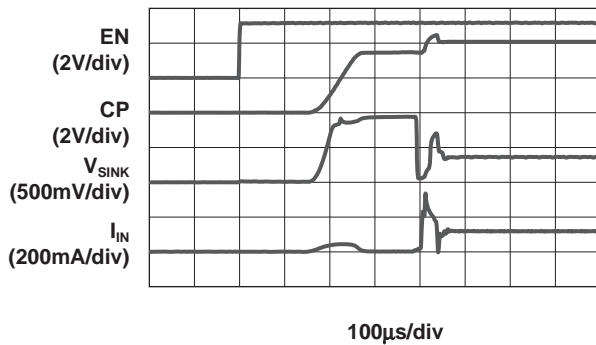

Turn-On to 2X Mode  
( $V_{IN} = 2.8V$ ; 20mA Load)

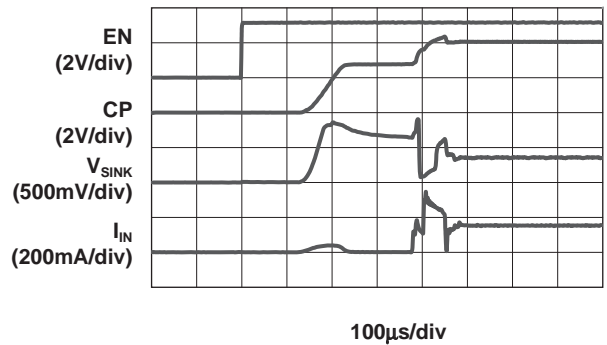

Turn-Off from 1.5X Mode  
( $V_{IN} = 3.5V$ ; 20mA Load)

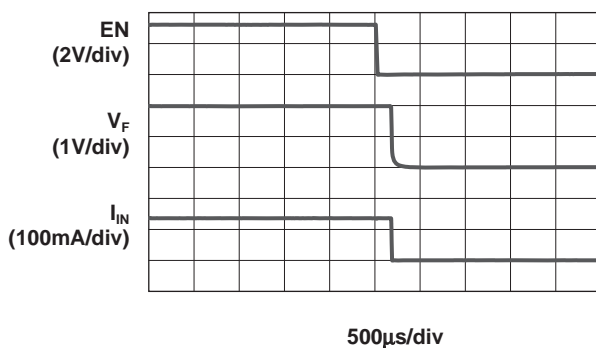

Current Matching vs. Temperature

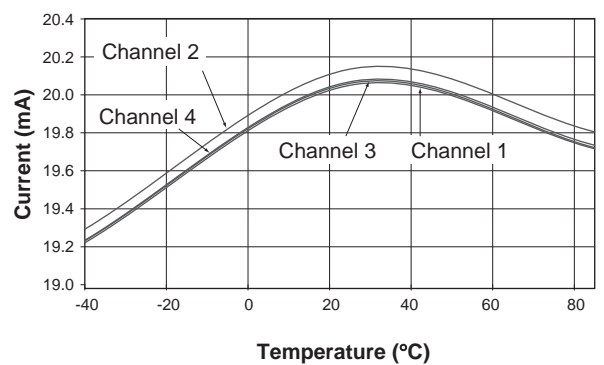

**Typical Characteristics**

**Load Characteristics**  
( $V_{IN} = 3.7V$ ; 1.5X Mode; 14mA Load)

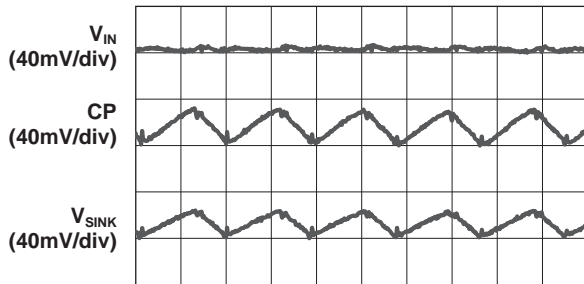

500ns/div

**Load Characteristics**  
( $V_{IN} = 2.7V$ ; 2X Mode; 14mA Load)

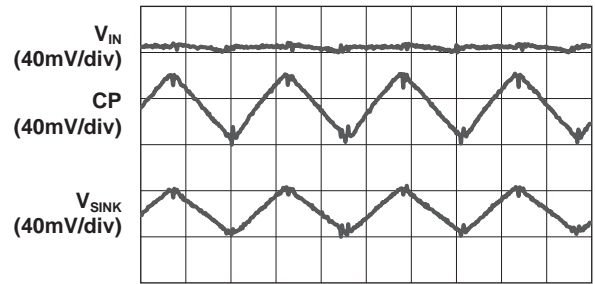

500ns/div

**Load Characteristics**  
( $V_{IN} = 3.9V$ ; 1.5X Mode; 20mA Load)

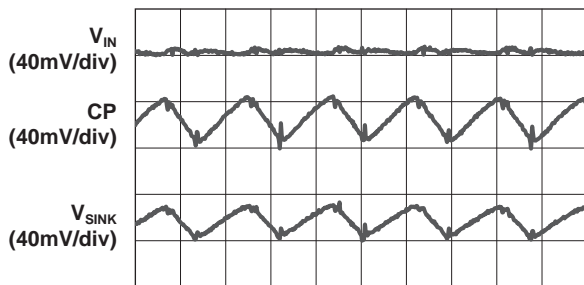

500ns/div

**Load Characteristics**  
( $V_{IN} = 2.9V$ ; 2X Mode; 20mA Load)

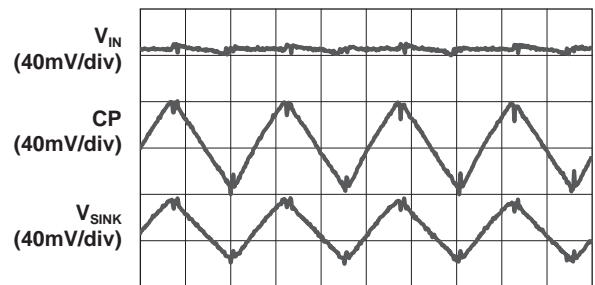

500ns/div

**$T_{LAT}$  vs.  $V_{IN}$**

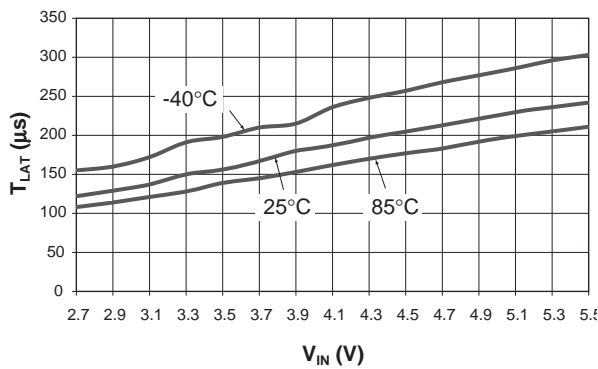

**$T_{OFF}$  vs.  $V_{IN}$**

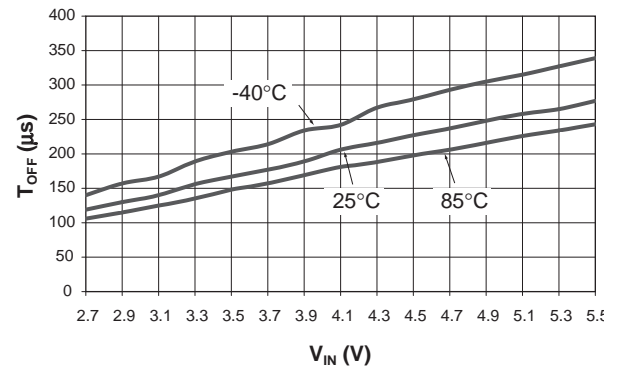

## Typical Characteristics

Input Ripple vs. Input Voltage

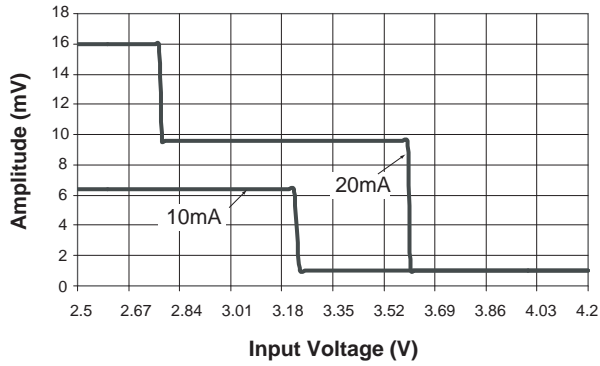

$V_{IH}$  vs.  $V_{IN}$

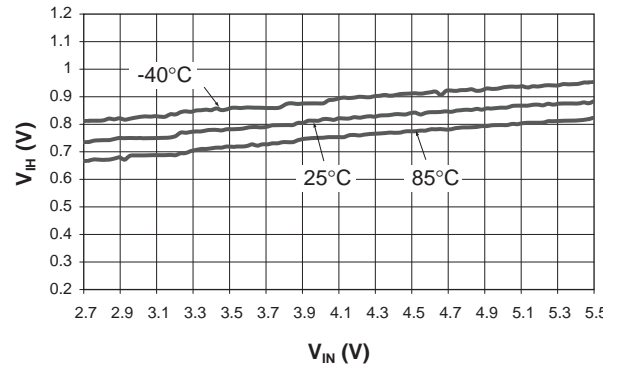

$V_{IL}$  vs.  $V_{IN}$

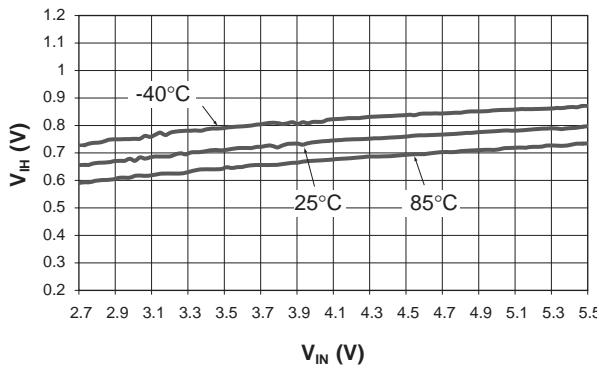

## Functional Block Diagram

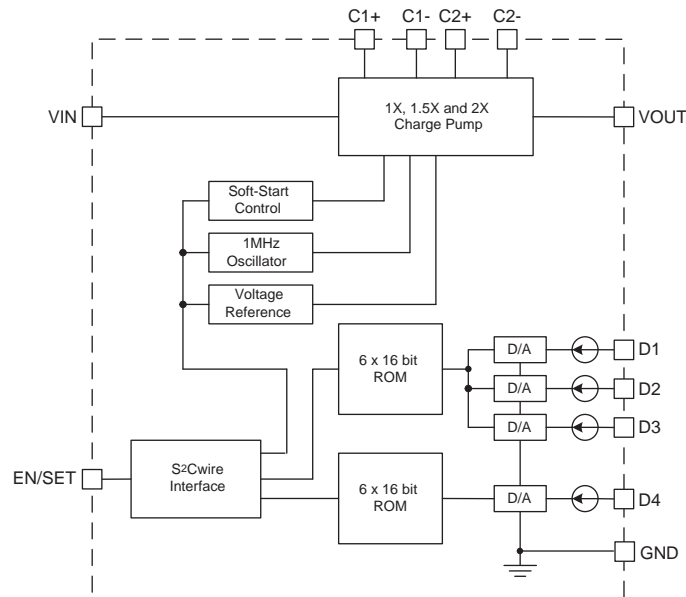

## Functional Description

The AAT3152 is a tri-mode load switch (1X) and high efficiency (1.5X or 2X) charge pump device intended for white LED backlight applications. To maximize power conversion efficiency, an internal sensing circuit monitors the voltage required on each constant current sink input and sets the load switch and charge pump modes based on the input battery voltage and the current sink input voltage. As the battery discharges over time, the AAT3152 charge pump is enabled when any of the four current sink inputs near dropout. The charge pump initially starts in 1.5X mode. If the charge pump output drops enough for any current source output to become close to dropout, the charge pump will automatically transition to 2X mode. The AAT3152 requires only four external components: two  $1\mu\text{F}$  ceramic capacitors for the charge pump flying capacitors ( $C_1$  and  $C_2$ ), one  $1\mu\text{F}$  ceramic input capacitor ( $C_{IN}$ ), and one  $0.33\mu\text{F}$  to  $1\mu\text{F}$  ceramic charge pump output capacitor ( $C_{OUT}$ ).

The four constant current sink inputs (D1 to D4) can drive four individual LEDs with a maximum current of 20mA each. The unused sink inputs must be connected to  $V_{OUT}$ , otherwise the part will operate only in 2X charge pump mode. The S²Cwire serial interface enables the AAT3152 and sets the current sink magnitudes. S²Cwire addressing allows independent control of two groups of current sink input: D1-D3 and D4.

## Constant Current Output Level Settings

The constant current sink levels for D1 to D4 are set via the serial interface. No PWM (pulse width modulation) or additional control circuitry is needed to control LED brightness. This feature greatly reduces the burden on a microcontroller or system IC to manage LED or display brightness, allowing the user to “set it and forget it.” With its high-speed serial interface (up to 1MHz data rate), the input sink current of the AAT3152 can be changed successively to brighten or dim LEDs, giving the users real-time control of LED brightness. Because the inputs D1 to D4 are true independent constant current sinks, the voltage observed on any single given input will be determined by the actual forward voltage ( $V_F$ ) for the LED being driven.

## S²Cwire Serial Interface

The current sink input magnitude on the AAT3152 is controlled by AnalogicTech’s S²Cwire serial digital input. It relies on the number of rising edges of the EN/SET pin to address and load the registers. S²Cwire latches data or address after the EN/SET pin has been held high for time  $T_{LAT}$ . The interface records rising edges of the EN/SET pin and decodes them into 16 different states, as indicated in the Current Setting table. There are four brightness levels for main or sub-display group with the possibility of individually turning ON or OFF each group.

## ChargePump™ High Efficiency 1X/1.5X/2X Charge Pump for White LED Applications

To further optimize power efficiency, the AAT3152 also offers four low-current levels for dim LED operation (Data 13-16). During this low-current mode, the internal supply current reduces to only 80µA typical.

The counter can be clocked at speeds up to 1MHz, such that intermediate states are not visible. The first rising edge of EN/SET enables the IC and initially sets the output LED current to 20mA. Once the final clock cycle is input for the desired brightness level, the EN/SET pin is held high to maintain the device output current at the programmed level. The device is disabled 500µs ( $T_{OFF}$ ) after the EN/SET pin transitions to a logic low state.

### AAT3152 Current Setting

Data	Main Group (D1-D3) $I_{OUT}$ (mA)	Sub Group (D4) $I_{OUT}$ (mA)
1	20	20
2	14	14
3	10	10
4	7	7
5	20	0
6	14	0
7	10	0
8	7	0
9	0	20
10	0	14
11	0	10
12	0	7
13	0.05	0.05
14	0.5	0.5
15	1	1
16	2	2

The EN/SET timing is designed to accommodate a wide range of data rates. After the first rising edge of EN/SET, the charge pump is enabled and reaches full capacity after the soft-start time ( $T_{SS}$ ). During the soft-start time, multiple clock pulses may be entered on the EN/SET pin to set the final output current level with a single burst of clocks. Alternatively, the EN/SET clock pulses may be entered one at a time to gradually increase the LED brightness over any desired time period. The current outputs remain constant as long as EN/SET remains in a logic high state. The current outputs are switched off after EN/SET has remained in a low state for at least the  $T_{OFF}$  timeout period; then, the AAT3152 enters shutdown mode and draws less than 1µA from  $V_{IN}$ . Data are reset to 0 during shutdown.

### Auto-Disable Feature

The AAT3152 is equipped with an auto-disable feature for each LED channel. After the IC is enabled and started up, a test current of 150µA (typical) is forced through each sink channel. The channel will be disabled if the voltage of that particular current sink pin does not drop to a certain threshold. This feature is very convenient for disabling an unused channel (by tying the DX pin to  $V_{OUT}$ ) or during an LED fail short event.

### Thermal Protection

The AAT3152 has a built-in thermal protection circuit that will shut down the charge pump if the die temperature rises above the thermal limit, as is the case during a short circuit of the  $V_{OUT}$  pin.

### S<sup>2</sup>Cwire Serial Interface Timing

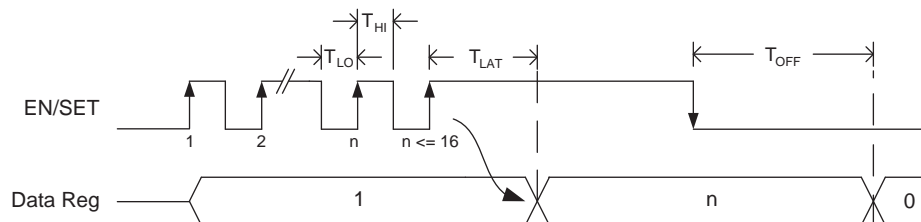

## Applications Information

### LED Selection

Although the AAT3152 is specifically intended for driving white LEDs, the device can also be used to drive most types of LEDs with forward voltage specifications ranging from 2.0V to 4.7V. LED applications may include main and sub-LCD display backlighting, camera photo-flash applications, color (RGB) LEDs, infrared (IR) diodes for remotes, and other loads benefiting from a controlled output current generated from a varying input voltage. Since the D1 to D4 input current sinks are matched with negligible voltage dependence, the LED brightness will be matched regardless of the specific LED forward voltage ( $V_f$ ) levels. In some instances (e.g., in high-luminous-output applications such as photo-flash), it may be necessary to drive high- $V_f$  type LEDs. The low-dropout current sinks in the AAT3152 make it capable of driving LEDs with forward voltages as high as 4.7V at full current from an input supply as low as 3.0V. Outputs can be paralleled to drive high-current LEDs without complication.

### Device Switching Noise Performance

The AAT3152 operates at a fixed frequency of approximately 1MHz to control noise and limit harmonics that can interfere with the RF operation of cellular telephone handsets or other communication devices. Back-injected noise appearing on the input pin of the charge pump is 20mV peak-to-peak, typically ten times less than inductor-based DC/DC boost converter white LED backlight solutions. The AAT3152 soft-start feature prevents noise transient effects associated with in-rush currents during start-up of the charge pump circuit.

### Capacitor Selection

Careful selection of the four external capacitors  $C_{IN}$ ,  $C_1$ ,  $C_2$ , and  $C_{OUT}$  is important because they will affect turn-on time, output ripple, and transient performance. Optimum performance will be obtained when low Equivalent Series Resistance (ESR) ceramic capacitors are used. In general, low ESR may be defined as less than 100m $\Omega$ . A value of 1 $\mu$ F for all four capacitors is a good starting point when choosing capacitors. If the LED current sources are only programmed for light current levels, then the capacitor size may be decreased.

### Capacitor Characteristics

Ceramic composition capacitors are highly recommended over all other types of capacitors for use with the AAT3152. Ceramic capacitors offer many advantages over their tantalum and aluminum electrolytic counterparts. A ceramic capacitor typically has very low ESR, is lowest cost, has a smaller PCB footprint, and is non-polarized. Low ESR ceramic capacitors help to maximize charge pump transient response. Since ceramic capacitors are non-polarized, they are not prone to incorrect connection damage.

### Equivalent Series Resistance

ESR is an important characteristic to consider when selecting a capacitor. ESR is a resistance internal to a capacitor that is caused by the leads, internal connections, size or area, material composition, and ambient temperature. Capacitor ESR is typically measured in milliohms for ceramic capacitors and can range to more than several ohms for tantalum or aluminum electrolytic capacitors.

### Ceramic Capacitor Materials

Ceramic capacitors less than 0.1 $\mu$ F are typically made from NPO or COG materials. NPO and COG materials typically have tight tolerance and are stable over temperature. Larger capacitor values are typically composed of X7R, X5R, Z5U, or Y5V dielectric materials. Large ceramic capacitors, typically greater than 2.2 $\mu$ F, are often available in low-cost Y5V and Z5U dielectrics, but capacitors greater than 1 $\mu$ F are typically not required for AAT3152 applications. Capacitor area is another contributor to ESR. Capacitors that are physically large will have a lower ESR when compared to an equivalent material, smaller capacitor. These larger devices can improve circuit transient response when compared to an equal value capacitor in a smaller package size.

### Thermal Protection

The AAT3152 has a built-in thermal protection circuit that will shut down the charge pump if the die temperature rises above the thermal limit, as is the case during a short circuit of the  $V_{OUT}$  pin.

## Ordering Information

Package	Marking <sup>1</sup>	Part Number (Tape and Reel) <sup>2</sup>
TDFN33-12	NQXY	AAT31521WP-T1



All AnalogicTech products are offered in Pb-free packaging. The term “Pb-free” means semiconductor products that are in compliance with current RoHS standards, including the requirement that lead not exceed 0.1% by weight in homogeneous materials. For more information, please visit our website at <http://www.analogictech.com/aboutus/quality.php>.

## Package Information

TDFN33-12<sup>3</sup>

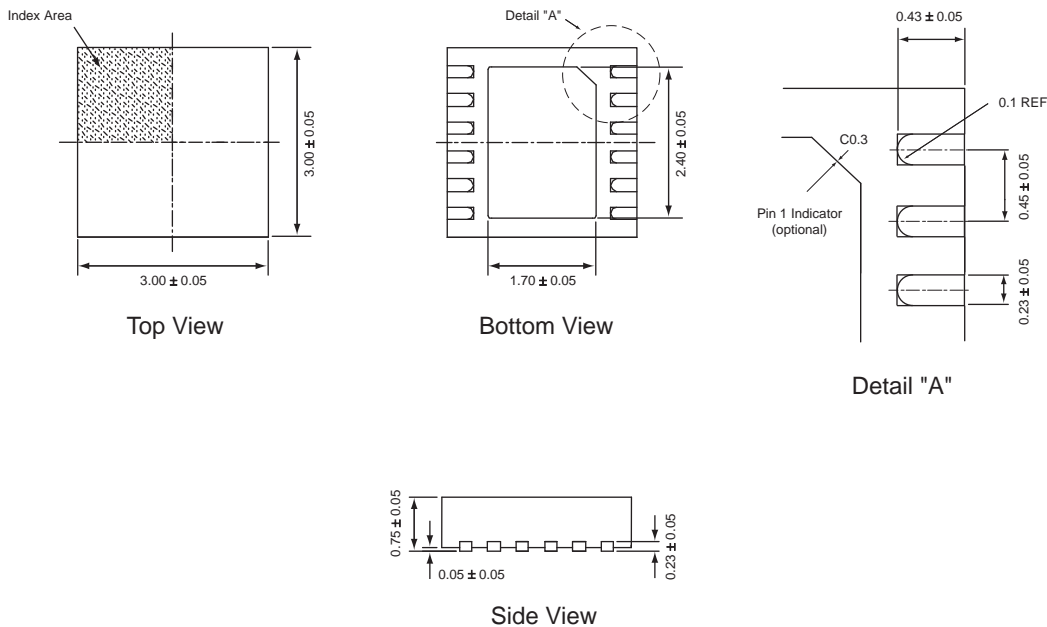

All dimensions in millimeters.

1. XYY = assembly and date code.
2. Sample stock is generally held on part numbers listed in **BOLD**.
3. The leadless package family, which includes QFN, TQFN, DFN, TDFN and STDFN, has exposed copper (unplated) at the end of the lead terminals due to the manufacturing process. A solder fillet at the exposed copper edge cannot be guaranteed and is not required to ensure a proper bottom solder connection.

**Advanced Analogic Technologies, Inc.**  
 3230 Scott Boulevard, Santa Clara, CA 95054  
 Phone (408) 737-4600  
 Fax (408) 737-4611



© Advanced Analogic Technologies, Inc. AnalogicTech cannot assume responsibility for use of any circuitry other than circuitry entirely embodied in an AnalogicTech product. No circuit patent licenses, copyrights, mask work rights, or other intellectual property rights are implied. AnalogicTech reserves the right to make changes to their products or specifications or to discontinue any product or service without notice. Except as provided in AnalogicTech's terms and conditions of sale, AnalogicTech assumes no liability whatsoever, and AnalogicTech disclaims any express or implied warranty relating to the sale and/or use of AnalogicTech products including liability or warranties relating to fitness for a particular purpose, merchantability, or infringement of any patent, copyright or other intellectual property right. In order to minimize risks associated with the customer's applications, adequate design and operating safeguards must be provided by the customer to minimize inherent or procedural hazards. Testing and other quality control techniques are utilized to the extent AnalogicTech deems necessary to support this warranty. Specific testing of all parameters of each device is not necessarily performed. AnalogicTech and the AnalogicTech logo are trademarks of Advanced Analogic Technologies Incorporated. All other brand and product names appearing in this document are registered trademarks or trademarks of their respective holders.