

General Description

The AAT3131 is a low noise, constant frequency charge pump DC/DC converter that uses a dual mode load switch (1X) and fractional (1.5X) conversion to maximize efficiency for white LED applications. The device can be used to produce current levels up to 20mA in three of its outputs and 30mA in one of its outputs to drive LEDs from a 2.7V to 5.5V input. Outputs may be operated individually or paralleled for driving higher-current LEDs. A low external parts count (two 1μF flying capacitors and two small 1μF capacitors at V_{IN} and OUT) makes the AAT3131 ideally suited for small battery-powered applications.

AnalogicTech's Simple Serial Control™ (S²Cwire™) interface is used to enable, disable, and set the LED drive current in two groups: the three 20mA outputs and the single 30mA output with multiple level logarithmic scales. The AAT3131 has a thermal management system to protect the device in the event of a short-circuit condition at the output pin. Built-in soft-start circuitry prevents excessive inrush current during start-up. A high charge pump switching frequency enables the use of very small external capacitors. A low-current shutdown feature disconnects the load from V_{IN} and reduces quiescent current to less than 1μA. The AAT3131 is available in a Pb-free 12-pin TSOPJW12 package and is rated over the -40°C to +85°C temperature range.

Features

- V_{IN} Range: 2.7V to 5.5V
- <1.0μA of Shutdown Current
- 1MHz Switching Frequency
- White LED Backlighting
- Fully Independent Display Lighting
- Dual Mode 1X and 1.5X Charge Pump for Maximum Efficiency
- Drives Low-V_F and High-V_F Type LEDs
- Up to Three 20mA Outputs
- Single 30mA Output
- Multi-Position Logarithmic Scale with Digital Control
- Low Noise Constant Frequency Operation
- Regulated Output Current
- Automatic Soft Start
- No Inductors
- Temperature Range: -40°C to +85°C
- 12-Pin TSOPJW Package

Applications

- Color (RGB) Lighting
- Programmable Current Source
- White LED Backlighting
- White Photo Flash for Digital Still Cameras

Typical Application

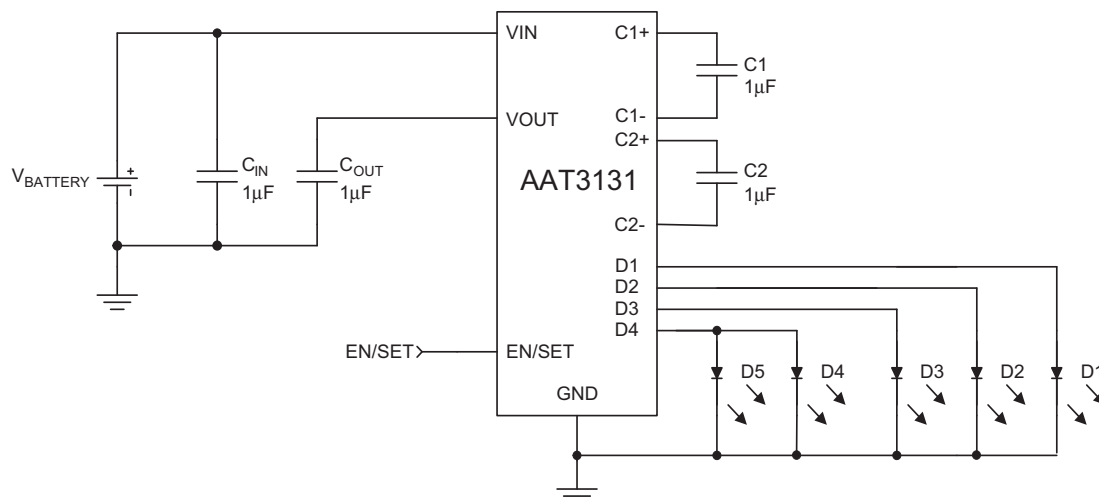

Pin Descriptions

Pin #	Symbol	Function
1	C2+	Flying capacitor 2 positive terminal. Connect a 1 μ F capacitor between C2+ and C2-.
2	OUT	Charge pump output. Requires 1 μ F capacitor connected between this pin and ground.
3	C1-	Flying capacitor 1 negative terminal.
4	C1+	Flying capacitor 1 positive terminal. Connect a 1 μ F capacitor between C1+ and C1-.
5	D3	Current source output #3.
6	D2	Current source output #2.
7	D4	Current source output #4.
8	D1	Current source output #1.
9	EN/SET	Control pin.
10	IN	Input power supply. Requires 1 μ F capacitor connected between this pin and ground.
11	GND	Ground.
12	C2-	Flying capacitor 2 negative terminal.

Pin Configuration

TSOPJW-12
(Top View)

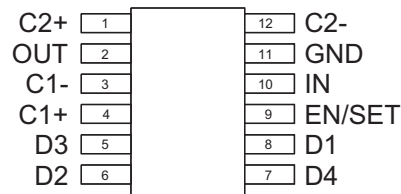

Absolute Maximum Ratings¹

Symbol	Description	Value	Units
V_{IN}	Input Voltage	-0.3 to 6	V
V_{OUT}	Charge Pump Output	-0.3 to 6	V
$F_{Bz}, V_{EN/SET}$	FB or EN/SET to GND Voltage	-0.3 to 6	V
$V_{EN/SET(MAX)}$	Maximum EN/SET to Input Voltage	$V_{IN} - 0.3$	V
I_{OUT}^2	Maximum DC Output Current	150	mA
T_J	Operating Junction Temperature Range	-40 to 150	°C
T_{LEAD}	Maximum Soldering Temperature (at leads, 10 sec.)	300	°C

Thermal Information³

Symbol	Description	Value	Units
θ_{JA}	Thermal Resistance	160	°C/W
P_D	Maximum Power Dissipation ⁴ ($T_A = 25^\circ\text{C}$)	625	mW

1. Stresses above those listed in Absolute Maximum Ratings may cause permanent damage to the device. Functional operation at conditions other than the operating conditions specified is not implied. Only one Absolute Maximum Rating should be applied at any one time.

2. Based on long-term current density limitation.

3. Mounted on an FR4 board.

4. Derate 6.25mW/°C above 25°C.

ChargePump™ High Efficiency IX/1.5X Fractional Charge Pump for White LED Applications
Electrical Characteristics¹
 $V_{IN} = 3.5V$, $C_{IN} = C_{OUT} = C_1 = C_2 = 1.0\mu F$; $T_A = -40$ to $+85^\circ C$, unless otherwise noted. Typical values are $T_A = 25^\circ C$.

Symbol	Description	Conditions	Min	Typ	Max	Units
Input Power Supply						
V_{IN}	Operation Range		2.7		5.5	V
I_{CC}	Operating Current	$3.0 \leq V_{IN} \leq 5.5$, Active, No Load Current		1.8	3.5	mA
I_{SHDN}	Shutdown Current	EN = 0			1.0	μA
I_{DX}	Maximum Output Current D1 to D3	$3.0 \leq V_{IN} \leq 5.5$	18	20	22	mA
I_{DX}	Maximum Output Current D4	$3.0 \leq V_{IN} \leq 5.5$	27	30	33	mA
$I_{(D-Match)}$	Current Matching Between Any Two Outputs	VD1:D3 = 3.6, $V_{IN} = 3.3V$		0.5		%
η_{CP}	Charge Pump Section Efficiency	$V_{IN} = 3.5V$, $I_{OUT(TOTAL)} = 90mA$, Measured from IN to OUT		93		%
Charge Pump Section						
T_{SS}	Soft-Start Time			200		μs
F_{CLK}	Clock Frequency			1000		kHz
EN/ SET						
$V_{EN(L)}$	Enable Threshold Low				0.5	V
$V_{EN(H)}$	Enable Threshold High		1.4			V
$T_{EN/SET LO}$	EN/SET Low Time	$V_{EN/SET} < 0.5$	0.3		75	μs
$T_{EN/SET HI}$	Minimum EN/SET High Time	$V_{EN/SET} > 1.4$		50		ns
T_{OFF}	EN/SET Off Timeout	$V_{EN/SET} < 0.5$			500	μs
Input Current	EN/SET Input Leakage		-1		1	μA

1. The AAT3131 is guaranteed to meet performance specifications over the -40 to +85°C operating temperature range and is assured by design, characterization, and correlation with statistical process controls.

Typical Characteristics

Unless otherwise noted, $V_{IN} = 3.5V$, $C_{IN} = C_{OUT} = C_1 = C_2 = 1\mu F$, $T_A = 25^\circ C$.

Efficiency vs. Input Voltage
(4x20mA)

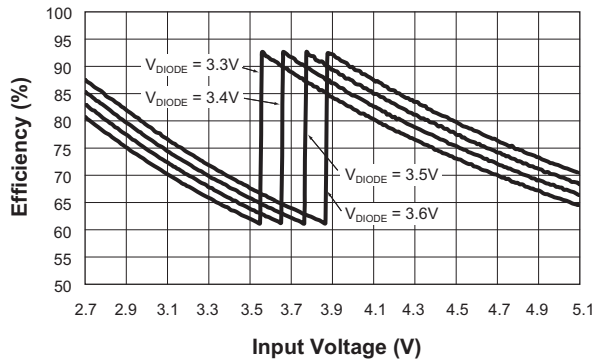

I_{DIODE} vs. Input Voltage
(4x20mA)

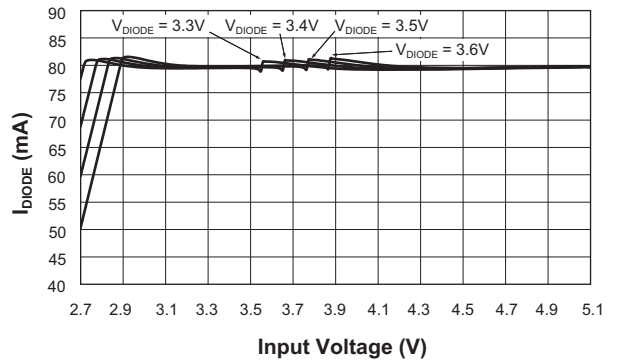

Quiescent Current vs. Input Voltage

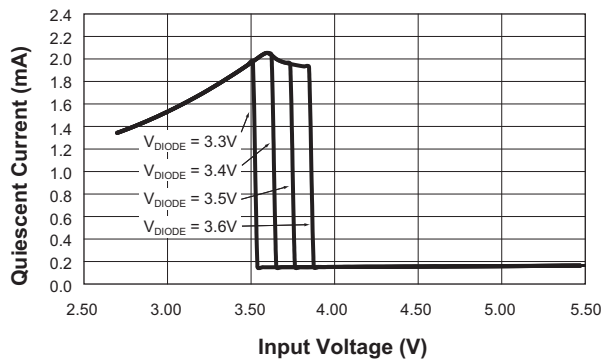

V_{IH} and V_{IL} vs. V_{IN}

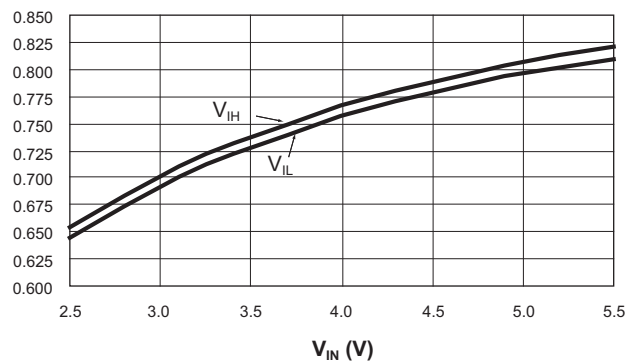

Turn-On to Full-Scale Charge Pump

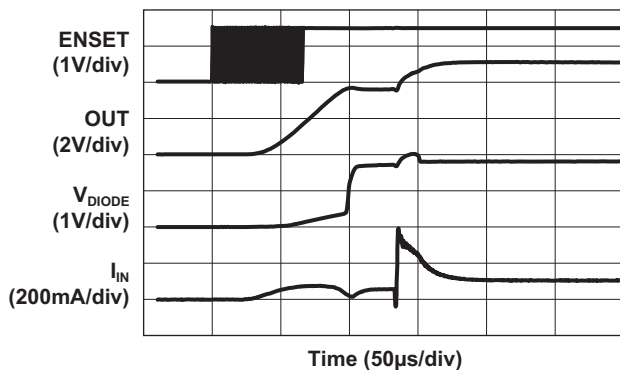

Turn-On to Full-Scale Load Switch

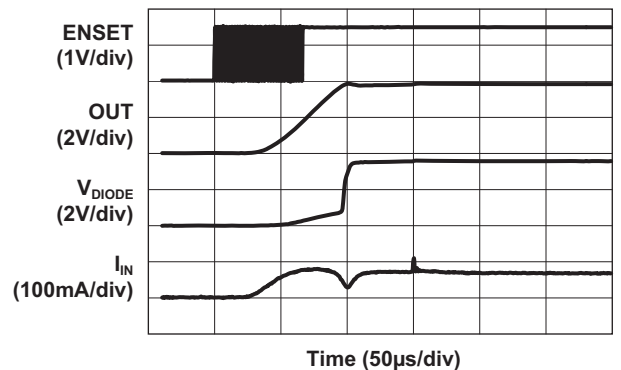

Typical Characteristics

Unless otherwise noted, $V_{IN} = 3.5V$, $C_{IN} = C_{OUT} = C_1 = C_2 = 1\mu F$, $T_A = 25^\circ C$.

**Charge Pump to Load Switch
(80mA)**

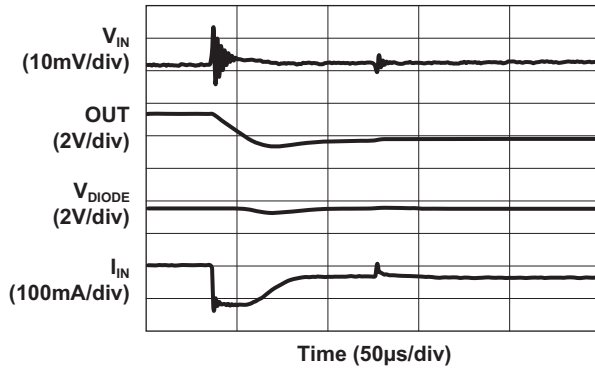

**Load Switch to Charge Pump
(80mA)**

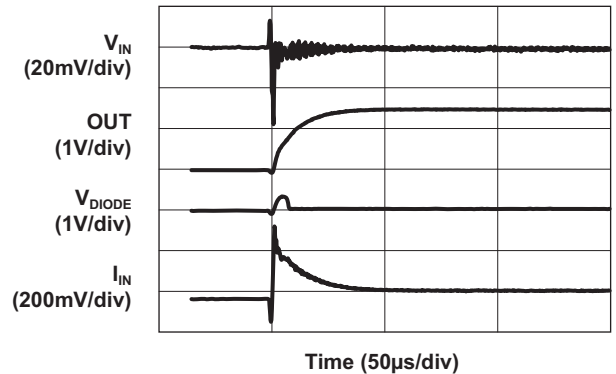

Turn-Off

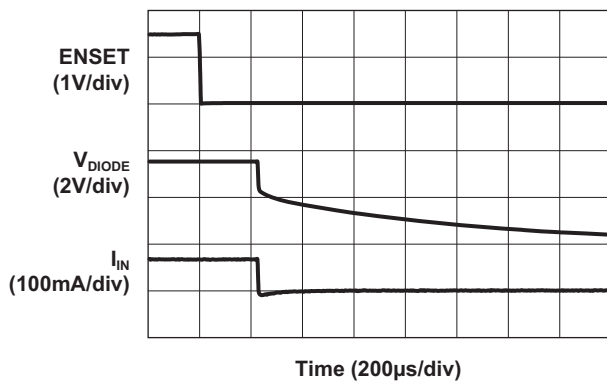

80mA Load Characteristics

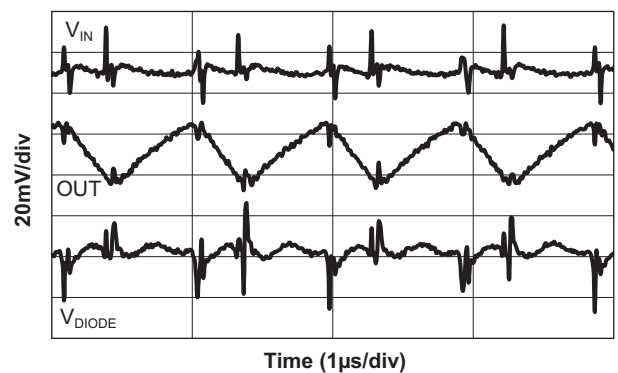

Functional Block Diagram

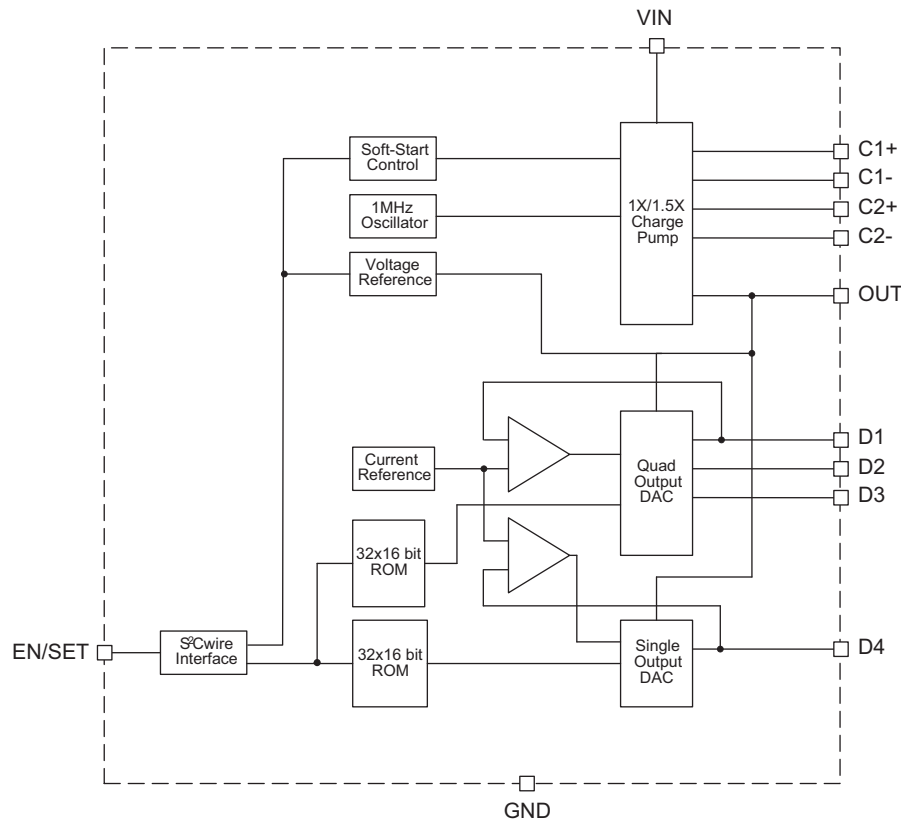

Functional Description

The AAT3131 is a dual mode load switch (1X) and high efficiency (1.5X) fractional charge pump device intended for white LED backlight applications. The fractional charge pump consists of a low dropout linear voltage regulator followed by a 1.5X charge pump with multiple current-source outputs. To maximize power conversion efficiency, an internal feedback control sensing circuit monitors the voltage required on the constant current source outputs. This control circuit then sets the load switch and charge pump functions based upon the input voltage level versus the output voltage level needed. This function significantly enhances overall device efficiency when the input voltage level is greater than the voltage required at the constant current source outputs. The 1X load switch/1.5X charge pump mode decision is based on the voltage levels sensed on either the D1 output or the

D4 output, whichever is greater. Switchover between the 1.5X (charge pump) operating mode and the 1X (load switch) mode occurs automatically (as a function of input and output voltages) and does not require user intervention to maintain maximum efficiency.

The AAT3131 requires only four external components: two $1\mu\text{F}$ ceramic capacitors for the charge pump flying capacitors (C_1 and C_2), one $1\mu\text{F}$ ceramic input capacitor (C_{IN}), and one $0.33\mu\text{F}$ to $1\mu\text{F}$ ceramic output capacitor (C_{OUT}). The LDO/1.5X charge pump output is converted into three (D1 to D3) constant current outputs to drive three individual LEDs with a maximum current of 20mA each, and one (D4) constant current output with a maximum current of 30mA. The current source output magnitude is controlled by the EN/SET serial data interface. The interface records rising edges of the EN/SET pin and decodes them into 32 addresses corresponding to indi-

ChargePump™ High Efficiency IX/1.5X Fractional Charge Pump for White LED Applications

vidual current level settings. The 32 addresses are divided such that outputs D1 to D3 can be controlled independently of output D4. For Addresses 1 to 8, 9 to 16, 17 to 24, and 25 to 32, outputs D1 to D3 start at 0mA and increase from 0.5mA to 20mA in three 8dB steps and three 2.5dB steps. Output D4 remains constant over these address ranges, which provides orthogonal control of the two channels. For Addresses 1 to 8, D4 is set to 0mA; for Addresses 9 to 16, D4 is set to 1mA; for Addresses 17 to 24, D4 is set to 15mA; and for Addresses 25 to 32, D4 is set to 30mA. This is summarized in Table 1 and Figure 1.

The modulo 32 interface wraps states back to State 1 after the 32nd clock. With each EN/SET pulse, the output current changes to the next setting in the address decoding. To change settings to the previous address decoding, 31 EN/SET clock pulses are required. The counter can be clocked at speeds up to 1MHz, so that intermediate states are not visible. The first rising edge of EN/SET enables the IC and initially sets the output LED currents to 0mA. Additional clocks are required to set the desired current level. Once the final clock cycle is input for the desired brightness level, the EN/SET pin is held high to maintain the device output current at the programmed level. The device is disabled 500µs after the EN/SET pin transitions to a logic low state.

Address	Current Level Settings (mA)	
	D1-3	D4
1	0.0	0.0
2	0.5	0.0
3	1.3	0.0
4	3.3	0.0
5	8.3	0.0
6	11.1	0.0
7	15.0	0.0
8	20.0	0.0
9	0.0	1.0
10	0.5	1.0
11	1.3	1.0
12	3.3	1.0
13	8.3	1.0
14	11.1	1.0
15	15.0	1.0
16	20.0	1.0
17	0.0	15.0
18	0.5	15.0
19	1.3	15.0
20	3.3	15.0
21	8.3	15.0
22	11.1	15.0
23	15.0	15.0
24	20.0	15.0
25	0.0	30.0
26	0.5	30.0
27	1.3	30.0
28	3.3	30.0
29	8.3	30.0
30	11.1	30.0
31	15.0	30.0
32	20.0	30.0

Table 1: Constant Current Source Output Programming Levels.

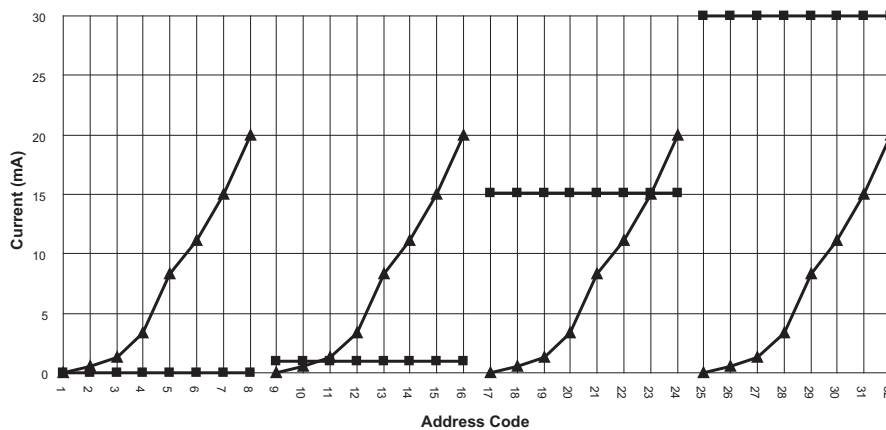

Figure 1: Output Level Current Settings.

Applications Information

Constant Current Output Level Settings

The constant current source output amplitude for outputs D1 to D3 and D4 are set via the serial interface according to a logarithmic scale. Using a logarithmic scale, LED brightness appears linear with each increasing code count. Because the outputs D1 to D4 are true independent constant current sources, the voltage observed on any single given output will be determined by the actual forward voltage (V_F) for the LED being driven.

Since the output current of the AAT3131 is programmable through its S²Cwire interface, no PWM (pulse width modulation) or additional control circuitry are needed to control LED brightness. This feature greatly reduces the burden on a microcontroller or system IC to manage LED or display brightness, allowing the user to “set it and forget it.” Furthermore, with its high-speed serial interface (1MHz data rate), the output current of the AAT3131 can be changed successively to brighten or dim LEDs in smooth transitions (e.g., to fade out) or in abrupt steps, giving the user complete programmability and real-time control of LED brightness.

EN/ SET Serial Interface

The current source output magnitude is controlled by the EN/SET serial data interface. The interface records rising edges of the EN/SET pin and decodes them into 32 individual current level settings. The modulo 32 interface wraps states back to State 1 after the 32nd clock, so that the previous state is achieved by clocking the EN/SET pin 31 times. The counter can be clocked at speeds up to 1MHz, so that intermediate states are not visible. The first rising edge of EN/SET enables the IC and initially sets the output LED current to 0dB. Once the final clock cycle is input for the desired brightness level, the EN/

SET pin is held high to maintain the device output current at the programmed level. The device is disabled 500μs after the EN/SET pin transitions to a logic low state. The EN/SET timing is designed to accommodate a wide range of data rates. After the first rising edge of EN/SET, the charge pump is enabled and reaches full capacity after the soft-start time (T_{SS}). During the soft-start time, multiple clock pulses may be entered on the EN/SET pin to set the final output current level with a single burst of clocks. Alternatively, the EN/SET clock pulses may be entered one at a time to gradually increase the LED brightness over any desired time period. A constant current is sourced as long as EN/SET remains in a logic high state. The current source outputs are switched off after EN/SET has remained in a low state for at least the T_{OFF} timeout period.

LED Selection

The AAT3131 is specifically intended for driving white LEDs. However, the device design will allow the AAT3131 to drive most types of LEDs with forward voltage specifications ranging from 2.0V to 4.3V. LED applications may include main and sub-LCD display backlighting, camera photo-flash applications, color (RGB) LEDs, infrared (IR) diodes for remotes, and other loads benefiting from a controlled output current generated from a varying input voltage. Since the D1 to D4 output current sources are matched with negligible voltage dependence, the LED brightness will be matched regardless of the specific LED forward voltage (V_F) levels.

In some instances (e.g., in high luminous output applications such as photo flash), it may be necessary to drive high- V_F type LEDs. The low dropout current sources in the AAT3131 makes it capable of driving LEDs with forward voltages as high as 4.3V at full current from an input supply as low as 3.0V. Outputs can be paralleled to drive high-current LEDs without complication.

EN/ SET Timing Diagram

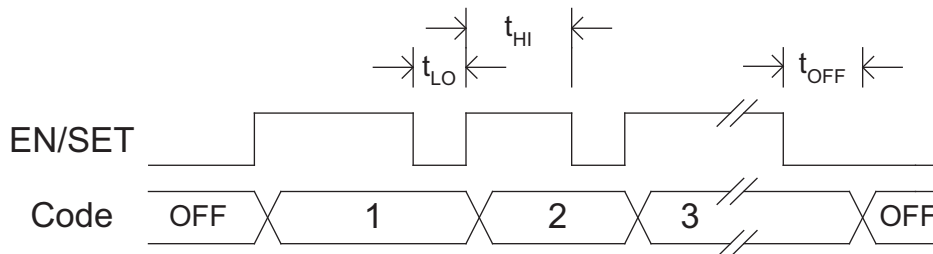

Device Switching Noise Performance

The AAT3131 operates at a fixed frequency of approximately 1MHz to control noise and limit harmonics that can interfere with the RF operation of cellular telephone handsets or other communication devices. Back-injected noise appearing on the input pin of the charge pump is 20mV peak-to-peak, typically ten times less than inductor-based DC/DC boost converter white LED backlight solutions. The AAT3131 soft-start feature prevents noise transient effects associated with inrush currents during start-up of the charge pump circuit.

Power Efficiency and Device Evaluation

The charge pump efficiency discussion in the following sections only accounts for efficiency of the charge pump section itself. Due to the unique circuit architecture and design of the AAT3131, it is very difficult to measure efficiency in terms of a percent value comparing input power over output power.

Since the AAT3131 outputs are pure constant current sources and typically drive individual loads, it is difficult to measure the output voltage for a given output (D1 to D4) to derive an overall output power measurement. For any given application, white LED forward voltage levels can differ, yet the output drive current will be maintained as a constant.

This makes quantifying output power a difficult task when taken in the context of comparing to other white LED driver circuit topologies. A better way to quantify total device efficiency is to observe the total input power to the device for a given LED current drive level. The best white LED driver for a given application should be based on trade-offs of size, external component count, reliability, operating range, and total energy usage...*not just % efficiency.*

The AAT3131 efficiency may be quantified under very specific conditions and is dependent upon the input voltage versus the output voltage seen across the loads applied to outputs D1 through D4 for a given constant current setting. Depending upon the case of V_{IN} being greater than the specific voltage seen across the load on D1 (or D4), the device will operate in load switch mode. If V_{IN} is less than the voltage required on the constant current source, the device will operate in 1.5X charge pump mode. Each of these two modes will yield different efficiency values. Refer to the following two sections for explanations for each operational mode.

Load Switch Mode Efficiency

The AAT3131 load switch mode is operational at all times and functions alone to enhance device power conversion efficiency when V_{IN} is greater than voltage across the load connected to the constant current source outputs. When in load switch mode, the voltage conversion efficiency is defined as output power divided by input power:

$$\eta = \frac{P_{OUT}}{P_{IN}}$$

The expression to define the ideal efficiency (η) can be rewritten as:

$$\eta = \frac{P_{OUT}}{P_{IN}} = \frac{V_{OUT} \times I_{OUT}}{V_{IN} \times I_{OUT}} = \frac{V_{OUT}}{V_{IN}}$$

-or-

$$\eta(\%) = 100 \left(\frac{V_{OUT}}{V_{IN}} \right)$$

Charge Pump Section Efficiency

The AAT3131 contains a fractional charge pump which will boost the input supply voltage in the event that V_{IN} is less than the voltage required on the constant current source outputs. The efficiency (η) can be simply defined as a linear voltage regulator with an effective output voltage that is equal to one and one half times the input voltage. Efficiency (η) for an ideal 1.5X charge pump can typically be expressed as the output power divided by the input power.

$$\eta = \frac{P_{OUT}}{P_{IN}}$$

In addition, with an ideal 1.5X charge pump, the output current may be expressed as 2/3 of the input current. The expression to define the ideal efficiency (η) can be rewritten as:

$$\eta = \frac{P_{OUT}}{P_{IN}} = \frac{V_{OUT} \times I_{OUT}}{V_{IN} \times 1.5I_{OUT}} = \frac{V_{OUT}}{1.5V_{IN}}$$

-or-

$$\eta(\%) = 100 \left(\frac{V_{OUT}}{1.5V_{IN}} \right)$$

ChargePump™ High Efficiency IX/1.5X Fractional Charge Pump for White LED Applications

For a charge pump with an output of 5V and a nominal input of 3.5V, the theoretical efficiency is 95%. Due to internal switching losses and IC quiescent current consumption, the actual efficiency can be measured at 93%. These figures are in close agreement for output load conditions from 1mA to 100mA. Efficiency will decrease as load current drops below 0.05mA, or when level of V_{IN} approaches V_{OUT} . Refer to the Typical Characteristics section of this datasheet for measured plots of efficiency versus input voltage and output load current for the given charge pump output voltage options.

Capacitor Selection

Careful selection of the four external capacitors C_{IN} , C_1 , C_2 , C_{OUT} is important because they will affect turn-on time, output ripple, and transient performance. Optimum performance will be obtained when low equivalent series resistance (ESR) ceramic capacitors are used; in general, low ESR may be defined as less than 100mΩ. A value of 1μF for all four capacitors is a good starting point when choosing capacitors. If the LED current sources are only programmed for light current levels, then the capacitor size may be decreased.

Capacitor Characteristics

Ceramic composition capacitors are highly recommended over all other types of capacitors for use with the AAT3131. Ceramic capacitors offer many advantages over their tantalum and aluminum electrolytic counterparts. A ceramic capacitor typically has very low ESR, is lowest cost, has a smaller PCB footprint, and is non-polarized. Low ESR ceramic capacitors help maximize charge pump transient response. Since ceramic capacitors are non-polarized, they are not prone to incorrect connection damage.

Equivalent Series Resistance

ESR is an important characteristic to consider when selecting a capacitor. ESR is a resistance internal to a capacitor that is caused by the leads, internal connections, size or area, material composition, and ambient temperature. Capacitor ESR is typically measured in milliohms for ceramic capacitors and can range to more than several ohms for tantalum or aluminum electrolytic capacitors.

Ceramic Capacitor Materials

Ceramic capacitors less than 0.1μF are typically made from NPO or C0G materials. NPO and C0G materials have tight tolerance and are stable over temperature. Large capacitor values are typically composed of X7R, X5R, Z5U, or Y5V dielectric materials. Large ceramic capacitors, greater than 2.2μF, are often available in low-cost Y5V and Z5U dielectrics, but capacitors greater than 1μF are usually not required for AAT3131 applications.

Capacitor area is another contributor to ESR. Capacitors that are physically large will have a lower ESR when compared to an equivalent material smaller capacitor. These larger devices can improve circuit transient response when compared to an equal value capacitor in a smaller package size.

Thermal Protection

The AAT3131 has a thermal protection circuit that will shut down the internal LDO and charge pump if the die temperature rises above the thermal limit, as is the case during a short-circuit of the OUT pin.

Driving Multiple LEDs, White LED Display Module Backlights, and Individual LEDs Connected in Parallel

The AAT3131 D1 to D4 outputs are true constant current sources capable of driving up to 20mA (D1 to D3) or 30mA (D4) each over the operation input voltage range. Since these outputs are true constant current sources, they may be connected in parallel to drive a single power output. Any combination of outputs (D1 to D4) may be connected in parallel. The maximum total output current is a sum of how many current sources are parallel connected. This feature is particularly useful to power pre-manufactured display modules which are pre-wired with white LED backlights connected in a parallel circuit configuration. Any combination of outputs may be connected in parallel to drive groups of LEDs. The AAT3131 internal current source reference circuit bases feedback from current sensed on the D1 and D4 outputs. For best operation, the only requirement for this type of application is the outputs D1 and D4 should always be connected to the load circuit.

ChargePump™ High Efficiency 1X/1.5X Fractional Charge Pump for White LED Applications

The AAT3131 may be used to drive multiple LEDs having differing forward voltages. Using feedback techniques, the current in D1 to D3 output currents sources are referenced to the current in the LED connected to D1. Current source output D4 is its own reference. If all LEDs are of similar type, the diodes will be matched in current, maintaining uniform LED brightness despite variations in manufacturer, production, etc.

However, if the diodes are dramatically different in type comprising a mix of high- V_F type and low- V_F -type LEDs, the AAT3131 has the capability to optimally and simultaneously drive up to four LEDs of one type and up to two LEDs of another type. This feature can be useful for driving different color LEDs; driving both display backlight and photo-flash LEDs; or for driving main-LCD and sub-LCD display LED backlights from a single charge pump IC.

For example, when driving independent RGB LEDs, the green and blue type LEDs typically require a high V_F to operate (e.g., 3.7V), while the red LED needs a low forward voltage (e.g., 2V). By connecting the green and blue diodes to outputs D1 to D3 and the red diodes to D4, good control and uniformity in brightness are maintained despite the 2V difference in the diode forward voltages. The AAT3131 determines if the 1.5X charge pump circuit is needed based on the voltage on D1 and D4, whichever is higher. If adequate voltage is available to drive the higher voltage LED (of output D1 or D4) without the charge pump running, the IC automatically switches into load switch (1X) mode to maximize efficiency.

Similarly, if a 4V photo-flash LED array is connected to outputs D1 through D3 (with the outputs shorted together) and two 3.3V sub-LCD display backlight LEDs are connected to output D4, then the AAT3131 can optimally drive each set of LEDs at the programmed current level (see Figure 2).

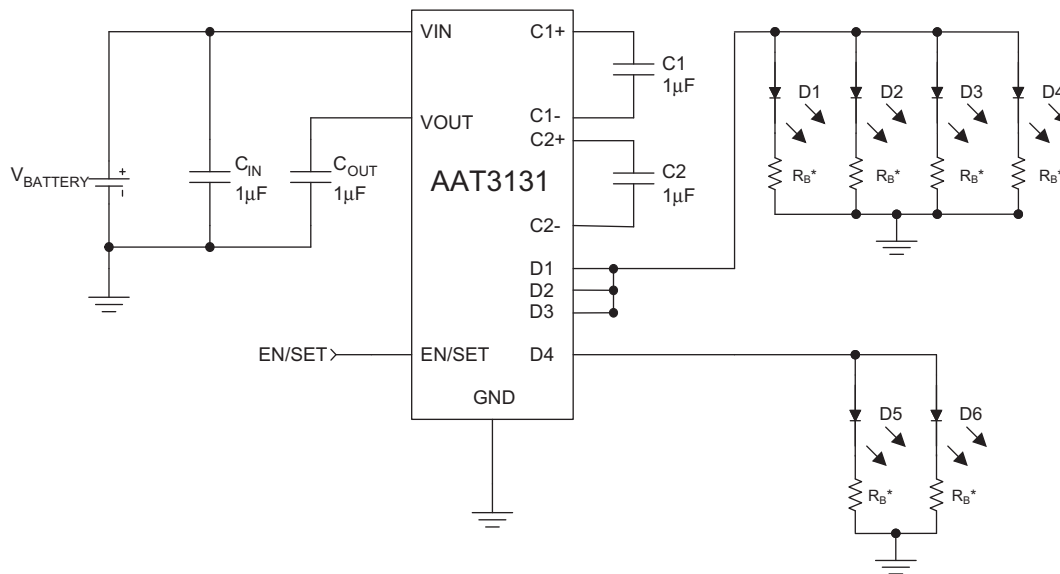

*In some applications, white LED forward voltages (V_F) can vary significantly. Ballast resistors between the LED cathodes and ground are recommended for balancing the forward voltage differences. The ballast resistor value may be approximated by the following equation:

$$R_B = \frac{V_{SOURCE} - V_F}{I_F}$$

Figure 2: AAT3131 Driving Two Groups of Paralleled White LEDs (e.g., main LCD and sub-LCD backlights).

ChargePump™ High Efficiency IX/1.5X Fractional Charge Pump for White LED Applications

Ordering Information

Package	Marking ¹	Part Number (Tape and Reel) ²
TSOPJW-12	KBXY	AAT31311TP-T1



All AnalogicTech products are offered in Pb-free packaging. The term “Pb-free” means semiconductor products that are in compliance with current RoHS standards, including the requirement that lead not exceed 0.1% by weight in homogeneous materials. For more information, please visit our website at <http://www.analogictech.com/aboutus/quality.php>.

Package Information

TSOPJW-12

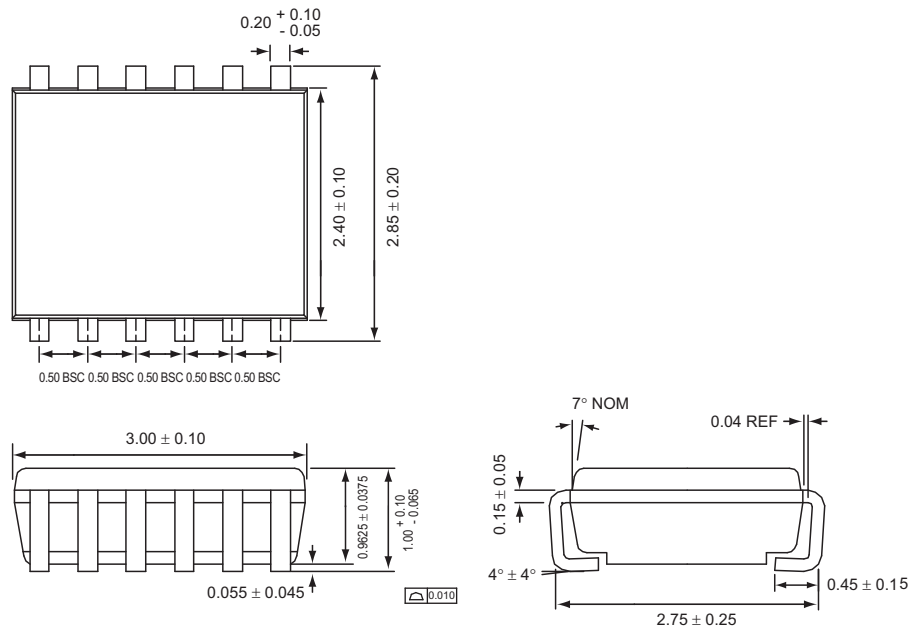

All dimensions in millimeters.

1. XYY = assembly and date code.
2. Sample stock is generally held on part numbers listed in **BOLD**.

Advanced Analogic Technologies, Inc.
 3230 Scott Boulevard, Santa Clara, CA 95054
 Phone (408) 737-4600
 Fax (408) 737-4611



© Advanced Analogic Technologies, Inc. AnalogicTech cannot assume responsibility for use of any circuitry other than circuitry entirely embodied in an AnalogicTech product. No circuit patent licenses, copyrights, mask work rights, or other intellectual property rights are implied. AnalogicTech reserves the right to make changes to their products or specifications or to discontinue any product or service without notice. Except as provided in AnalogicTech's terms and conditions of sale, AnalogicTech assumes no liability whatsoever, and AnalogicTech disclaims any express or implied warranty relating to the sale and/or use of AnalogicTech products including liability or warranties relating to fitness for a particular purpose, merchantability, or infringement of any patent, copyright or other intellectual property right. In order to minimize risks associated with the customer's applications, adequate design and operating safeguards must be provided by the customer to minimize inherent or procedural hazards. Testing and other quality control techniques are utilized to the extent AnalogicTech deems necessary to support this warranty. Specific testing of all parameters of each device is not necessarily performed. AnalogicTech and the AnalogicTech logo are trademarks of Advanced Analogic Technologies Incorporated. All other brand and product names appearing in this document are registered trademarks or trademarks of their respective holders.