

General Description

The AAT3119 is a general purpose high efficiency voltage regulated charge pump IC that can produce output current levels up to 150mA. As a voltage regulated output device, it may be used for general voltage boost applications or to power white, RGB, or flash type LEDs from a 2.7V to 5.5V input.

The voltage doubling charge pump architecture of the AAT3119 provides for a low external part count; just three small ceramic capacitors are needed. This makes the AAT3119 ideally suited for small battery-powered applications. This device operates from a fixed high frequency 1.2MHz oscillator which enables the use of very small external capacitors, one 1 μ F flying capacitor, and two 1 μ F bypass capacitors at IN and OUT.

The AAT3119 has built-in soft-start circuitry which prevents excessive inrush current from the source supply during startup. A low-current shutdown feature disconnects the load from V_{IN} and reduces quiescent current to less than 1.0 μ A when the device is disabled. The AAT3119 is available in a Pb-free, 8-pin SC70JW package and is rated over the -40°C to +85°C temperature range.

Features

- V_{IN} Range: 2.7V to 5.5V
- 150mA of Output Current
 - Peak Current up to 250mA
- Regulated Output Voltage
- 1.2MHz Switching Frequency
- Low Noise Constant Frequency Operation
- <1.0 μ A of Shutdown Current
- Automatic Soft Start
- Small Application Circuit
- Inductorless Boost
- 8-Pin SC70JW Package
- -40°C to +85°C Temperature Range

Applications

- Cellular Phones
- Digital Cameras
- Handheld Electronics
- PDAs
- White LED Backlighting
- White LED Camera Flash

Typical Application

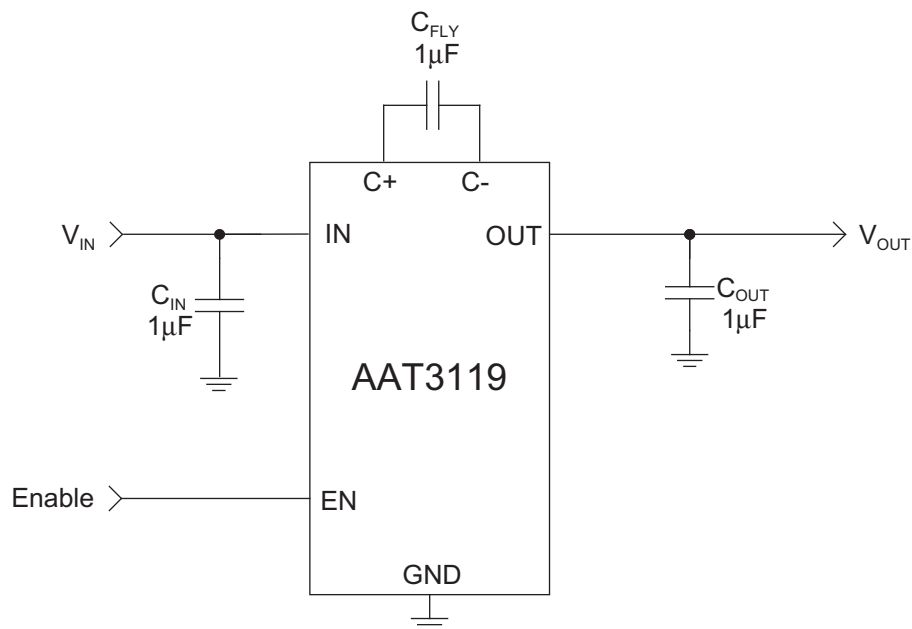

Pin Descriptions

Pin #	Symbol	Function
1	EN	Enable input control pin. When low, the device is disabled and consumes less than 1µA of current. This pin should not be left floating.
2	IN	Input power supply. A 1µF capacitor should be connected between this pin and ground.
3	OUT	Charge pump output. Connect a 1µF capacitor between this pin and ground.
4	C+	Flying capacitor positive terminal. Connect a 1µF capacitor between C+ and C-.
5	C-	Flying capacitor negative terminal.
6	GND	Ground connection.
7	GND	Ground connection.
8	GND	Ground connection.

Pin Configuration

**SC70JW-8
(Top View)**

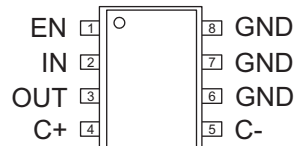

Absolute Maximum Ratings¹

Symbol	Description	Value	Units
V_{IN}	Input Voltage	-0.3 to 6.0	V
V_{OUT}	Charge Pump Output	-0.3 to 6.0	V
V_{EN}	EN to GND Voltage	-0.3 to 6.0	V
$V_{EN(MAX)}$	Maximum EN to Input Voltage	0.3	V
I_{OUT}	Maximum DC Output Current	250	mA
T_J	Operating Junction Temperature Range	-40 to 150	°C
T_{LEAD}	Maximum Soldering Temperature (at leads, 10 sec)	300	°C

Thermal Information²

Symbol	Description	Value	Units
Θ_{JA}	Thermal Resistance	160	°C/W
P_D	Maximum Power Dissipation ³	625	mW

1. Stresses above those listed in Absolute Maximum Ratings may cause permanent damage to the device. Functional operation at conditions other than the operating conditions specified is not implied. Only one Absolute Maximum Rating should be applied at any one time.
2. Mounted on an FR4 board.
3. Derate 6.25mW/°C above 25°C.

Electrical Characteristics¹

$V_{IN} = 3.3V$; $C_{IN} = C_{OUT} = C_{FLY} = 1.0\mu F$; $T_A = -40^{\circ}C$ to $85^{\circ}C$, unless otherwise noted. Typical values are $T_A = 25^{\circ}C$.

Symbol	Description	Conditions	Min	Typ	Max	Units
AAT3119-5.0						
Power Supply						
V_{IN}	Input Voltage Range		2.7		5.5	V
V_{OUT}	Output Voltage Tolerance	$2.7V < V_{IN} < 5V, I_{OUT} = 50mA$		± 4		%
	Output Voltage	$3.0V < V_{IN} < 5V, I_{OUT} = 100mA$	4.8	5.0	5.2	V
I_{CC}	Operating Current	$V_{IN} = 5.0V$, Active, No Load Current		2.0	4.5	mA
I_{SHDN}	Shutdown Current	EN = 0			1.0	μA
I_{OUT}	Maximum Output Current	$3.0 \leq V_{IN} \leq 5.5$	150			mA
η	Efficiency	$V_{IN} = 3.0V, I_{OUT} = 100mA$		82		%
EN						
$V_{EN(L)}$	Enable Threshold Low				0.4	V
$V_{EN(H)}$	Enable Threshold High	EN = 5.5V	1.4			V
I_i	Enable Input Current		-1.0		1.0	μA
Charge Pump						
T_{SS}	Soft-Start Time			200		μs
F_{CLK}	Clock Frequency			1200		kHz
AAT3119-4.5						
Power Supply						
V_{IN}	Input Voltage Range		2.7		5.5	V
V_{OUT}	Output Voltage	$2.7V < V_{IN} < 5V, I_{OUT} = 50mA$		± 4		%
		$3.0V < V_{IN} < 5V, I_{OUT} = 100mA$	4.32	4.5	4.68	V
I_{CC}	Operating Current	$V_{IN} = 4.5V$, Active, No Load Current		2.0	4.5	mA
I_{SHDN}	Shutdown Current	EN = 0			1.0	μA
I_{OUT}	Maximum Output Current	$3.0 \leq V_{IN} \leq 5.5$	150			mA
η	Efficiency	$V_{IN} = 2.7V, I_{OUT} = 100mA$		82		%
EN						
$V_{EN(L)}$	Enable Threshold Low				0.4	V
$V_{EN(H)}$	Enable Threshold High	EN = 5.5V	1.4			V
I_i	Enable Input Current		-1.0		1.0	μA
Charge Pump						
T_{SS}	Soft-Start Time			200		μs
F_{CLK}	Clock Frequency			1200		kHz

1. The AAT3119 is guaranteed to meet performance specifications from $0^{\circ}C$ to $70^{\circ}C$. Specification over the $-40^{\circ}C$ to $+85^{\circ}C$ operating temperature range is assured by design, characterization, and correlation with statistical process controls.

Typical Characteristics—AAT3119-5V

Output Voltage vs. Output Current

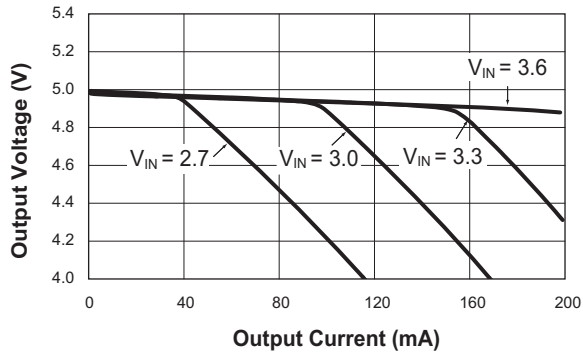

Supply Current vs. Supply Voltage

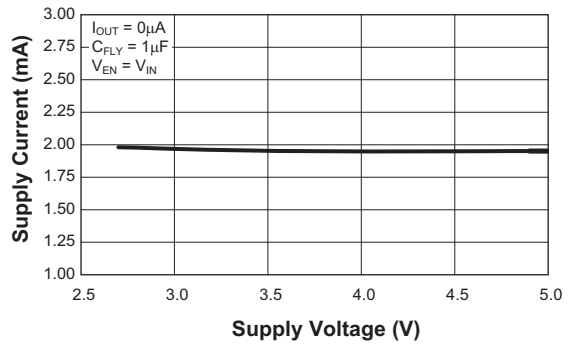

Supply Current vs. V_{EN}

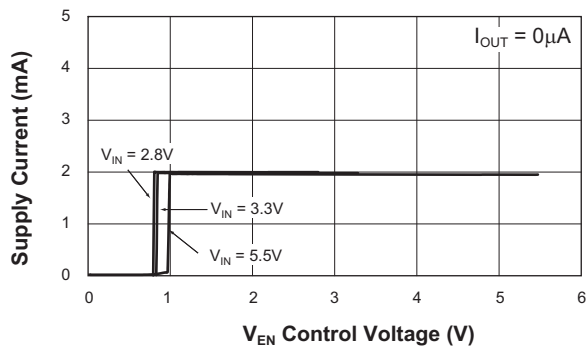

Efficiency vs. Supply Voltage

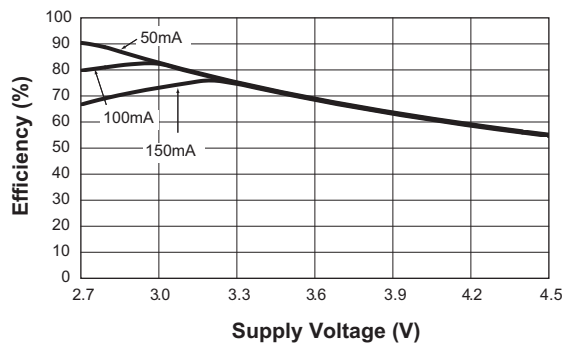

Efficiency vs. Load Current

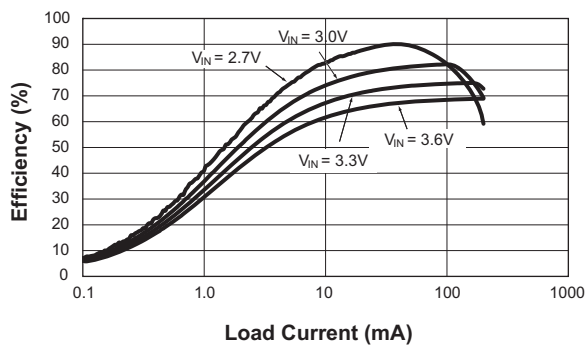

Oscillator Frequency vs. Supply Voltage

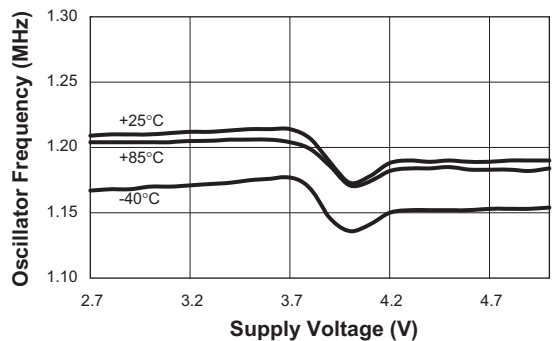

Typical Characteristics – AAT3119-5V

Start-Up Time with 50mA Load

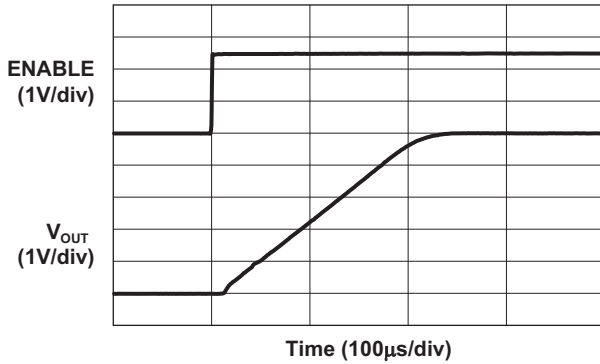

Start-Up Time with 100mA Load

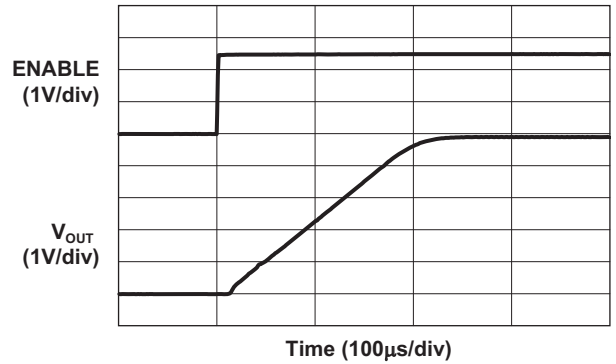

Load Response
(50mA Load)

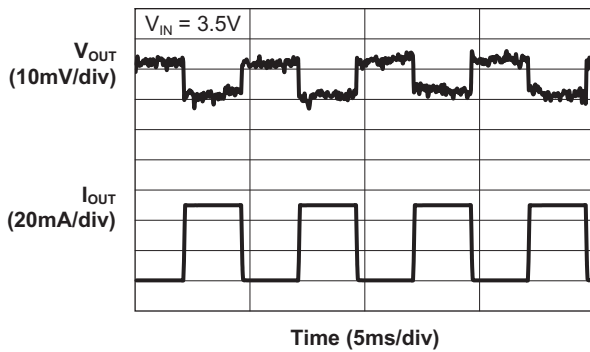

Load Response
(100mA Load)

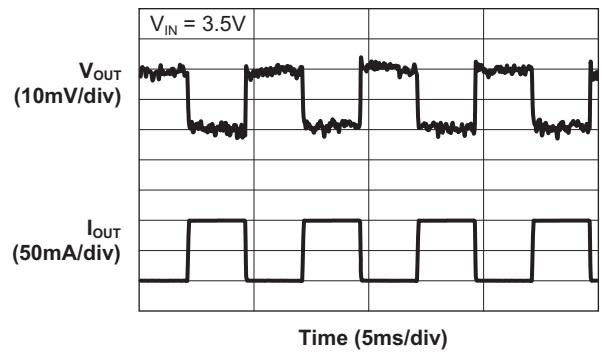

Output Ripple Voltage
(I_{OUT} = 50mA @ V_{IN} = 3.5V)

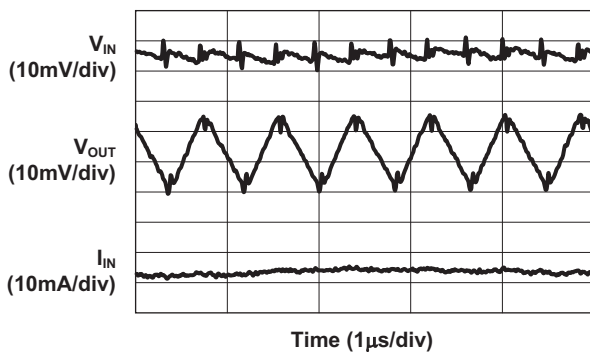

Output Ripple Voltage
(I_{OUT} = 100mA @ V_{IN} = 3.5V)

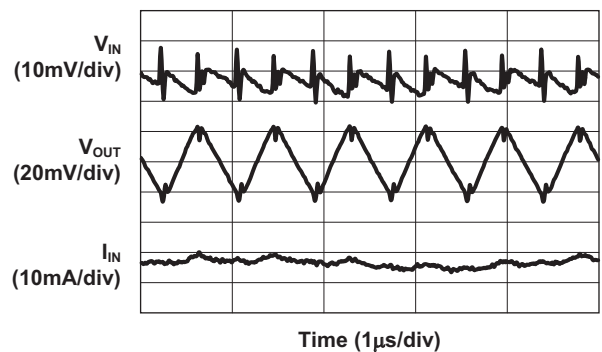

Typical Characteristics—AAT3119-4.5V

Output Voltage vs. Output Current

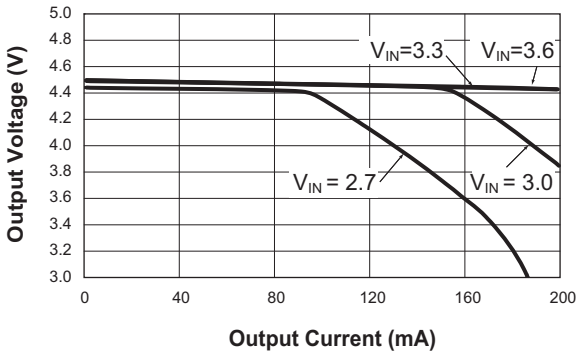

Supply Current vs. Supply Voltage

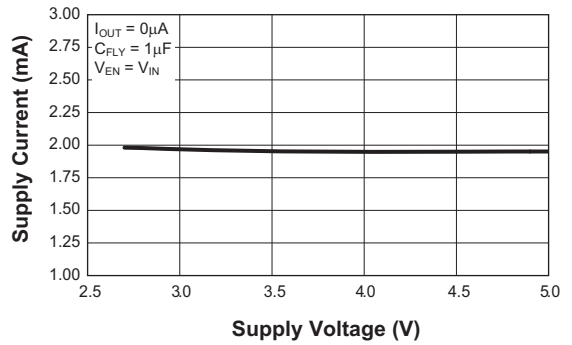

Supply Current vs. V_{EN}

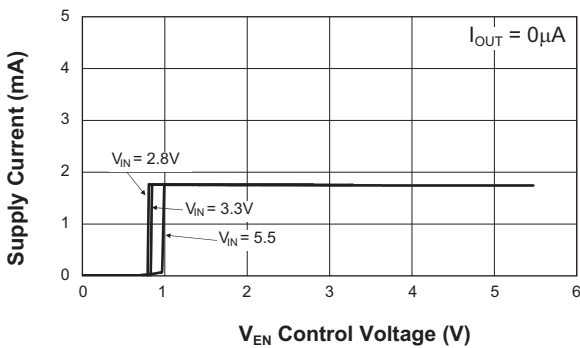

Efficiency vs. Supply Voltage

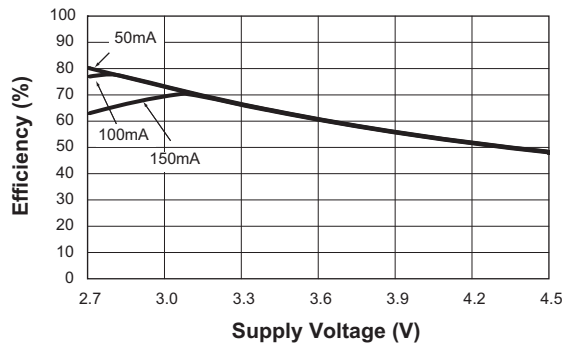

Efficiency vs. Load Current

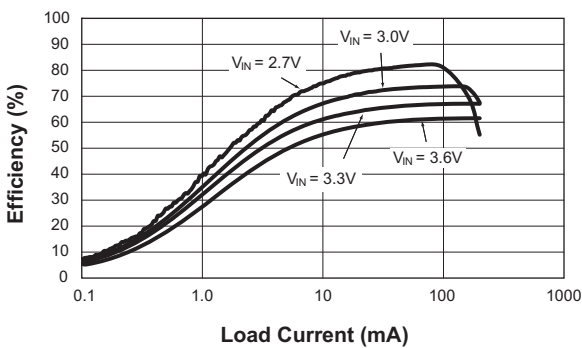

Oscillator Frequency vs. Supply Voltage

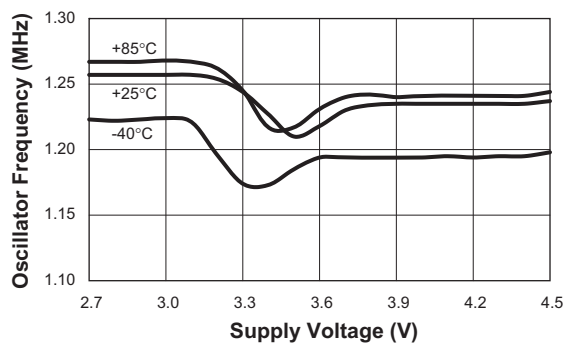

Typical Characteristics – AAT3119-4.5V

Load Response
(50mA Load)

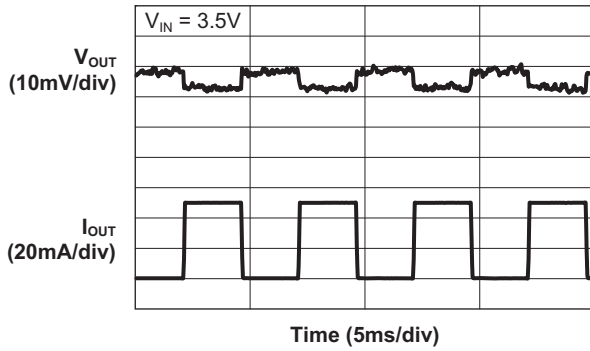

Load Response
(100mA Load)

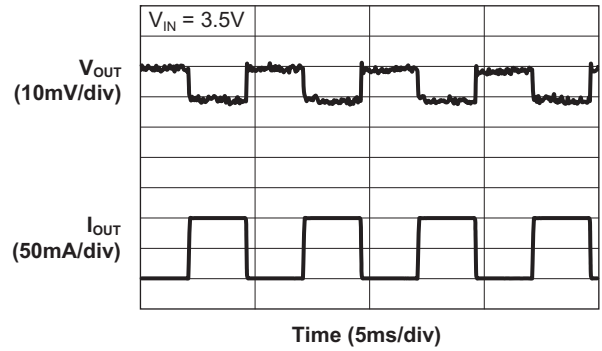

Output Ripple Voltage
(I_{OUT} = 50mA @ V_{IN} = 3.5V)

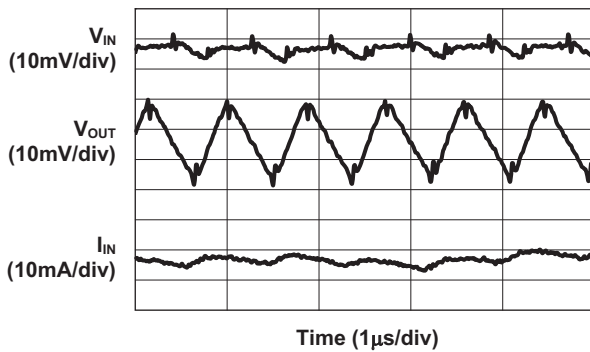

Output Ripple Voltage
(I_{OUT} = 100mA @ V_{IN} = 3.5V)

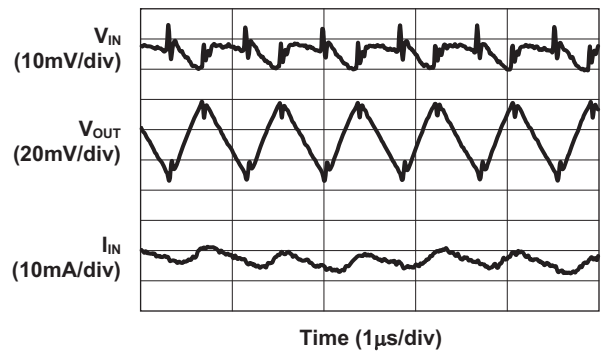

Maximum Current Pulse vs. Supply Voltage

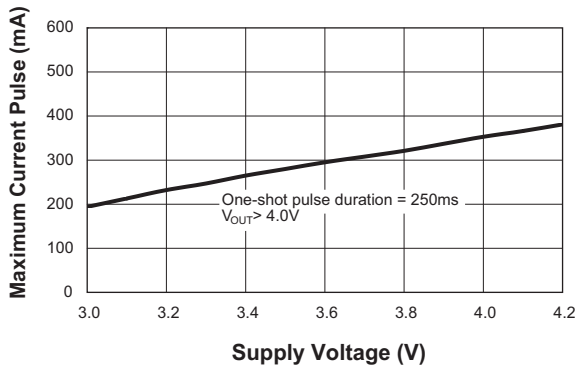

Startup

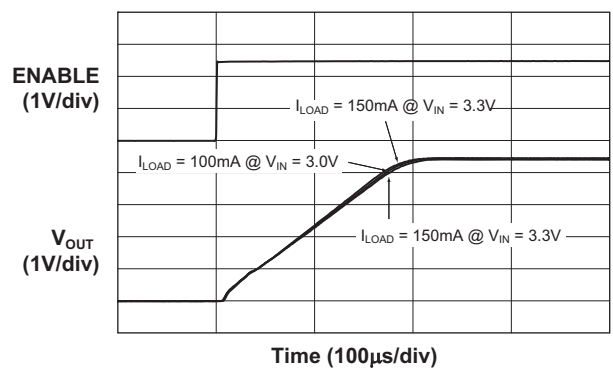

Typical Characteristics–AAT3119

V_{IN} vs. V_{IH}

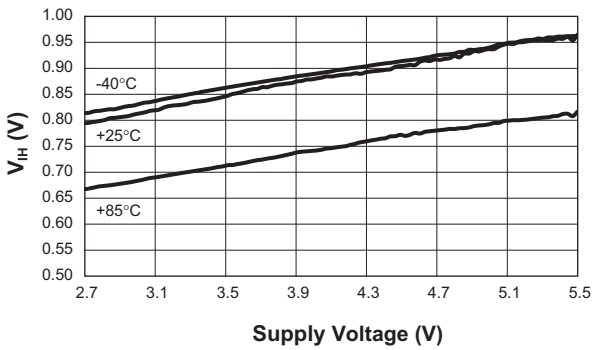

V_{IN} vs. V_{IL}

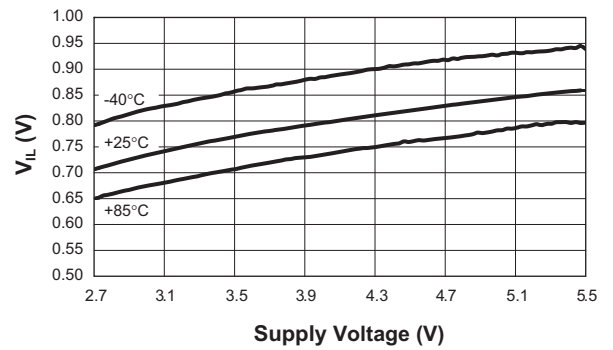

V_{EN} Threshold vs. Supply Voltage

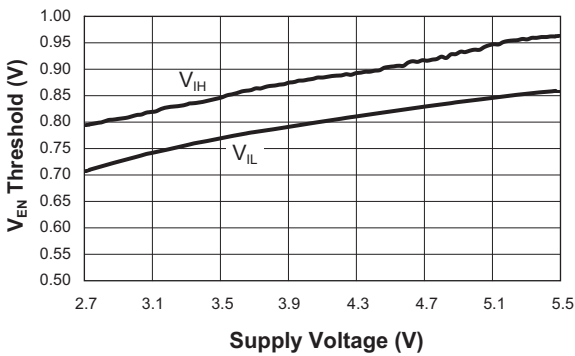

Normalized Output Voltage vs. Temperature

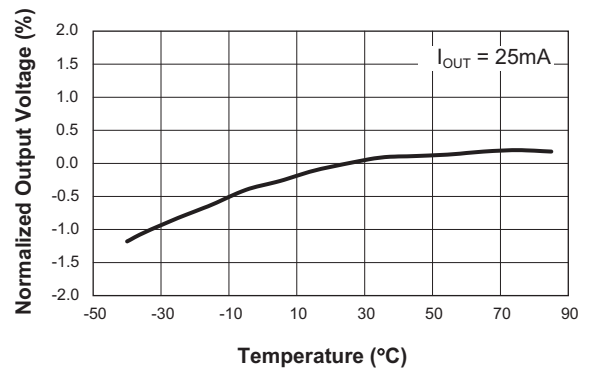

Functional Block Diagram

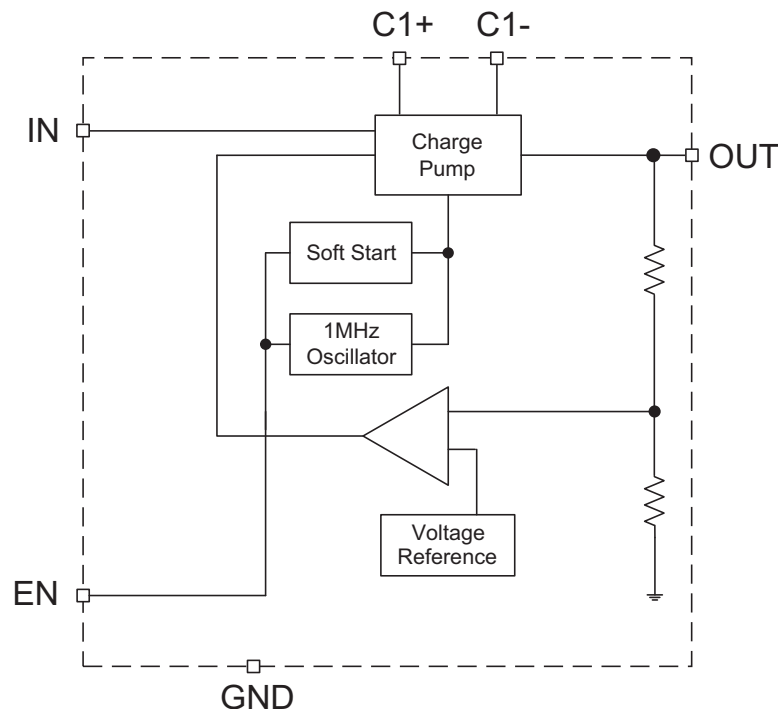

Functional Description

The AAT3119 is a 5.0V or 4.5V regulated voltage doubling charge pump device intended for general applications that require low noise voltage boost function from input supplies ranging from 2.7V to 5.5V. The charge pump is capable maintaining the regulated voltage output for continuous output current loads up to 150mA. This makes the AAT3119 ideal for general purpose voltage boost applications, driving white and RGB color LEDs, as well as USB OTG V_{BUS} supplies in portable products. The AAT3119 charge pump and regulation circuit is also capable of supplying peak pulse currents up to 250mA for 500ms. This makes the device suitable for many photo-flash LED applications.

The AAT3119 accomplishes the voltage boost function by utilizing a voltage doubling (2X) charge pump. The

charge pump block within the device uses low R_{DS} MOSFET switches to transfer charge from the input to output via a flying capacitor (C_{FLY}). This switching process is performed over two phases of each clock cycle which is set by the fixed 1.2MHz internal oscillator. On the first phase of each clock cycle, the flying capacitor is placed in parallel with the input (IN) and is charged to the level of the input voltage across C_{IN} . On the second phase of the switching cycle, the flying capacitor is reconfigured by the internal switches and placed in series with the input capacitor. C_{IN} and C_{FLY} are then placed across the output capacitor (C_{OUT}). The voltage seen on C_{OUT} is then two times that of C_{IN} . The AAT3119 contains an internal reference and feedback system that senses the charge pump output and controls the charge pump function to maintain an accurate regulated output voltage.

Because of the fixed 1.2MHz high frequency internal oscillator, the input, output, and flying capacitors are very small. This circuit architecture requires only one 1µF ceramic capacitor for the charge pump flying capacitor (C_{FLY}) and one 1µF ceramic capacitor for both C_{IN} and C_{OUT} .

The AAT3119 has a soft-start circuit to prohibit in-rush current when the device is enabled. This feature guarantees a smooth transition to the desired output voltage when the device is turned on. The system soft-start circuit is particularly useful in white LED backlight applications where the use of a PWM signal is employed as an LED dimming function. In limiting the input inrush current each time the device is turned on, the soft-start circuit helps minimize back-injected switching noise and transient supply current.

In the operating state, the AAT3119 typically consumes 2mA of quiescent operating current. The enable pin (EN) is an active high input. When pulled low, the AAT3119 is shut down, the quiescent current drops to less than 1µA, and the output is disconnected from the input.

Charge Pump Efficiency

The core of the AAT3119 is a regulated output voltage doubling charge pump. The efficiency (η) for an ideal voltage doubling charge pump can typically be expressed as the output power divided by the input power:

$$\eta = \frac{P_{OUT}}{P_{IN}}$$

In addition, with an ideal voltage doubling charge pump, the output current may be expressed as half the input current. The expression to define the ideal efficiency (η) can be rewritten as:

$$\eta = \frac{P_{OUT}}{P_{IN}} = \frac{V_{OUT} \times I_{OUT}}{V_{IN} \times 2I_{OUT}} = \frac{V_{OUT}}{2V_{IN}}$$

-or-

$$\eta(\%) = 100 \left(\frac{V_{OUT}}{2V_{IN}} \right)$$

For a charge pump with an output of 5.0 volts and a nominal input of 3.0 volts, the theoretical efficiency is 83.3%. Due to internal switching losses and IC quiescent current consumption, the actual efficiency can be measured at approximately 82%. Efficiency will decrease as the level of V_{IN} approaches that of the regulated V_{OUT} . Refer to the device typical characteristics curves for expected actual efficiency based on either input voltage or load current.

Capacitor Selection

Careful selection of the three external capacitors (C_{IN} , C_{FLY} , and C_{OUT}) is important because they will affect turn-on time, output ripple, efficiency, and load transient response. Optimum performance will be obtained when low equivalent series resistance (ESR) ceramic capacitors are used. In general, low ESR may be defined as less than 100mΩ. A value of 1µF for all three capacitors is a good starting point when designing with the AAT3119. This not only provides for a very small printed circuit board area, but cost is further reduced by the minimized bill of materials.

Input Capacitor

A 1µF multilayer ceramic chip capacitor is suggested for the input. This capacitor should be connected between the IN pin and ground. 1µF should be suitable for most applications. Even though the AAT3119 switching ripple and noise are very low, back-injected line noise may be further reduced by increasing the value of C_{IN} . Other types of capacitors may be used for C_{IN} at the cost of compromised circuit performance.

Output Capacitor

The output capacitor (C_{OUT}) should be connected between the OUT pin and ground. A 1µF ceramic capacitor is also suggested in this position. Switching noise and ripple seen on the charge pump output increases with load current. Typically 1µF is sufficient for minimizing output ripple seen by the load circuit. If the load current in an application is low, or if higher levels of switching ripple can be tolerated, C_{OUT} can be reduced as low as 0.33µF. If application circuits with greater load current demands

require lower switching ripple amplitudes, C_{OUT} may be increased to values above $1\mu\text{F}$. Capacitor types other than ceramic capacitors can be used for C_{OUT} . However, capacitors comprised of materials other than ceramic will typically have a greater value of ESR, resulting in increased output switching ripple.

Flying Capacitor

Due to the switching operation of the voltage doubling circuit topology, current flow through the flying capacitor is bi-directional. The flying capacitor selected must be a non-polarized type. A $1\mu\text{F}$ low ESR ceramic capacitor is ideal for this application.

Capacitor Characteristics

Ceramic composition capacitors are highly recommended over all other types of capacitors for use with the AAT3119. Ceramic capacitors offer many advantages over their tantalum and aluminum electrolytic counterparts. A ceramic capacitor typically has very low ESR, is lowest cost, has a smaller PCB footprint, and is non-polarized. Low ESR ceramic capacitors help maximize charge pump transient response. Since ceramic capacitors are non-polarized, they are not prone to incorrect connection damage.

Equivalent Series Resistance: ESR is an important characteristic to consider when selecting a capacitor. ESR is a resistance internal to a capacitor that is determined by the leads, internal connections, size or area, material composition, and ambient temperature. Capacitor ESR is typically measured in milliohms for ceramic capacitors and can range to more than several ohms for tantalum or aluminum electrolytic capacitors.

Ceramic Capacitor Materials: Ceramic capacitors less than $0.1\mu\text{F}$ are typically made from NPO or COG materials. NPO and COG materials typically have tight tolerance and are stable over temperature. Large capacitor values are typically composed of X7R, X5R, Z5U, or Y5V dielectric materials. Large ceramic capacitors, typically greater than $2.2\mu\text{F}$, are often available in low-cost Y5V and Z5U dielectrics, but large capacitors are not required in most AAT3119 applications. Capacitor area is another contributor to ESR. Capacitors that are physically large will have a lower ESR when compared to an equivalent material smaller capacitor. These larger devices can improve circuit transient response when compared to an equal value capacitor in a smaller package size.

Applications Information

White LED Backlight Driver

LED Selection: In applications where the AAT3119 is utilized as a white LED backlight driver, LEDs with forward voltages up to 5.0V may be used. The AAT3119 is available in two regulated output voltage versions: 4.5V and 5.0V. The output voltage option selected will determine the maximum LED forward voltage that can be driven. The trade-off for the lower 4.5V output voltage version is the device's ability to supply greater output current. Refer to the "Output Voltage vs. Output Current" curves in the Typical Characteristics section of this datasheet to determine the best AAT3119 output voltage option based on the requirements of a given application.

LED Ballast Resistors: To set the maximum brightness of white LEDs connected in parallel from a voltage source supply, a ballast resistor connected between each LED cathode and ground is required. Refer to the application schematic in Figure 1. The maximum brightness is determined by the forward current (I_F) through the respective LED for a given forward voltage (V_F). The typical forward voltage of a specific LED is usually stated in the typical characteristics of the given LED manufacturer's datasheet. The correct ballast resistor value can be determined by the following equation:

$$R_B = \frac{(V_{OUT} - V_F)}{I_F}$$

Where:

R_B = Ballast resistor value in ohms (Ω)

V_{OUT} = Regulated charge pump output voltage

V_F = LED forward voltage at the desired forward current

I_F = Desired LED forward current

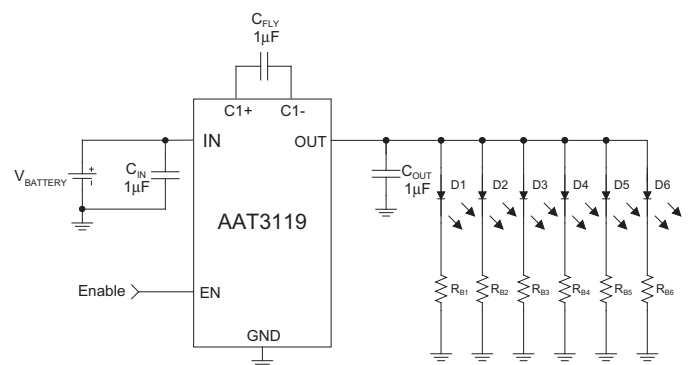

Figure 1: White LED Driver.

Flash LED Driver

The AAT3119 can source 250mA for pulsed loads up to 500ms from an input supply as low as 3.3V. This makes the device well suited for low-cost flash LED driver applications in portable products. Typically the 4.5V output version of the AAT3119 should be selected for photo-flash LED applications, as it can maintain better voltage regulation at higher pulsed load current levels (refer to Figure 2). The limitation of this option is that the greatest flash LED forward voltage (V_F) that can be driven is 4.5V at the maximum set forward current (I_F) for the application. Flash LEDs with forward voltage (V_F) levels up to 5.0V can be driven by the AAT3119 5.0V output option. However, the maximum current for a 500ms pulse will be reduced. Refer to the Typical Characteristics curves for peak output current levels for a given minimum input voltage.

The forward current (I_F) through the flash LED may be determined with the use of a series ballast resistor. The typical forward voltage (V_F) for the flash LED in a given application should be derived from the LED manufacturer's datasheet for the desired forward current (I_F) of the flash application. Once the forward current has been determined, the flash ballast resistor can be calculated using the following equation:

$$R_F = \frac{(V_{OUT} - V_F)}{I_F}$$

Where:

- R_F = Flash ballast resistor value in ohms (Ω)
- V_{OUT} = Regulated charge pump output voltage (typically 4.5V)
- V_F = Flash LED forward voltage at the desired forward current
- I_F = Desired flash LED forward current

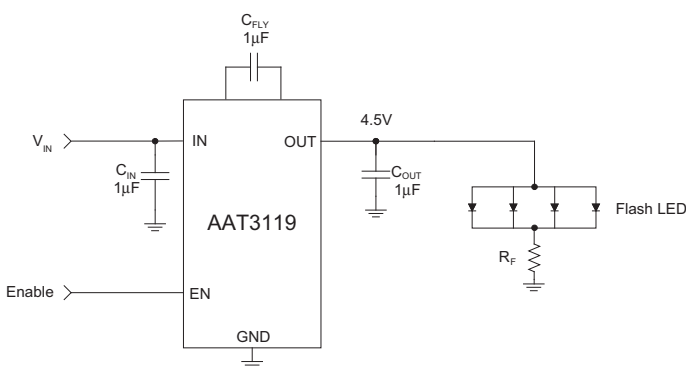

Figure 2: Flash LED Application.

The flash LED function can be controlled by the AAT3119 enable pin in most applications. The device start-up time into a maximum load is about 200µs, thus eliminating the need for pre-flash control synchronization.

If a "light" or "movie" mode is also needed along with the flash function, this can be accomplished with the addition of a second ballast resistor with a flash function gating MOSFET switch as shown in Figure 3. Refer to the following equations for the calculation of flash and light resistors, R_F and R_L .

$$R_L = \frac{(V_{OUT} - V_F)}{I_F}$$

Where:

- R_L = Light mode ballast resistor value in ohms (Ω)
- V_{OUT} = Regulated charge pump output voltage (typically 4.5V)
- V_F = Flash LED forward voltage at the desired forward current
- I_F = Desired flash LED forward current in the "light" mode

$$R_F = \left[\frac{(V_{OUT} - V_F)}{I_F} \right] - R_{DS}$$

Where:

- R_F = Flash ballast resistor value in ohms (Ω)
- R_{DS} = Flash gating MOSFET on resistance
- V_{OUT} = Regulated charge pump output voltage (typically 4.5V)
- V_F = Flash LED forward voltage at the desired forward current
- I_F = Desired flash LED forward current

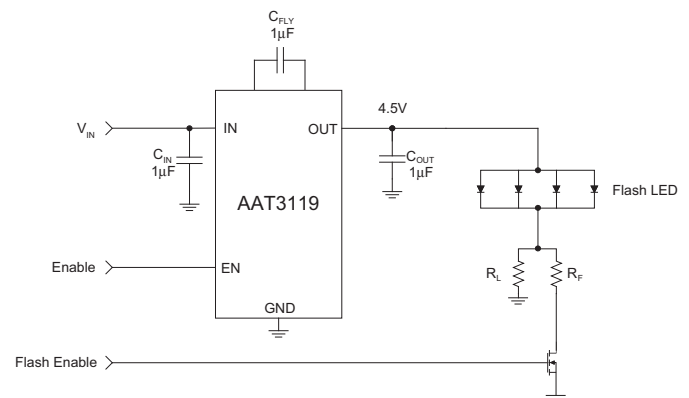

Figure 3: Flash LED Driver with Gated Flash Application.

Layout Considerations

For the AAT3119, the high charge pump switching frequencies and large peak transient currents require careful printed circuit board layout. As a general rule for charge pump boost converters, the three external capacitors should be located as closely as possible to the device package with minimum length trace connections. Maximize ground plane around the AAT3119 charge pump and make sure all external capacitor are connected to the immediate power ground plane. A local component side ground plane is recommended. If this is not possible due to layout area limitations, assure good ground connections by the use of large or multiple printed circuit board vias.

Refer to the basic AAT3119 evaluation board layout shown in Figure 4 and the evaluation board schematic shown in Figure 5 for an example of the recommended charge pump layout design.

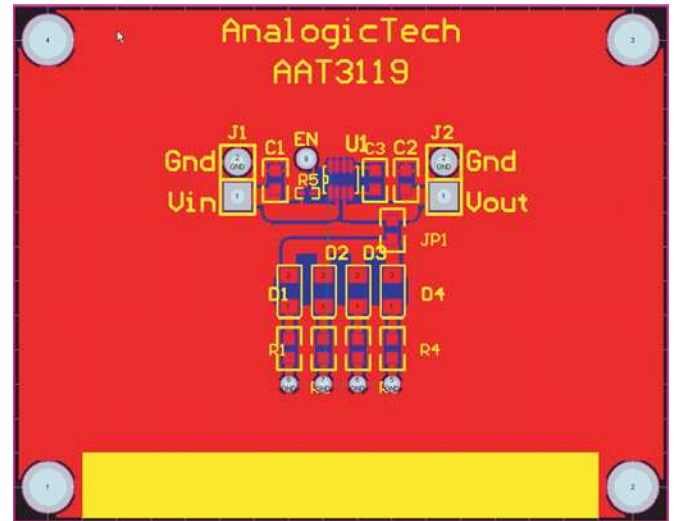

Figure 4: AAT3119 Evaluation Board Top Side Layout.

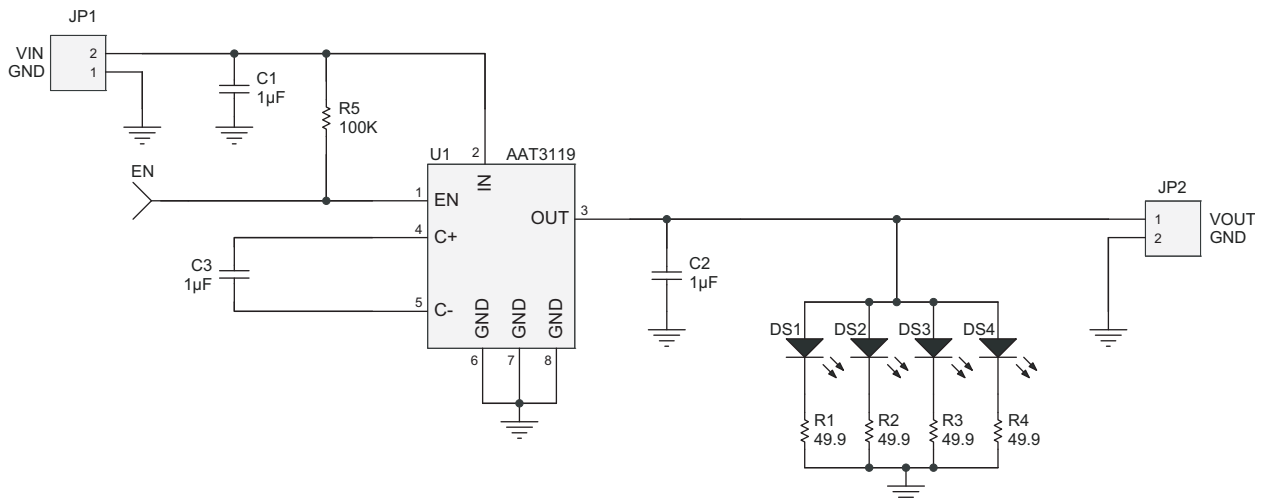

Figure 5: AAT3119 Evaluation Board Schematic Diagram.

Quantity	Designator	Description	Value	Footprint	Manufacturer	Part Number
1	U1	High Efficiency 2X Charge Pump		SC70JW-8	AnalogicTech	AAT3119
1	R5	100K 5% 1/8 W 0603	100K	0603	Vishay	CRCW----1003F
4	R1, R2, R3, R4	49.9Ω 1/8W 0805	49.9	0805	Vishay	CRCW---49R9F
2	JP1, JP2	Header, 2-Pin 2mm		HDR1X2	Sullin	S2105-40-ND
1	EN	Test Pin		PIN1	Mill Max	6821-0-0001-00-00-08-0
4	DS1, DS2, DS3, DS4	White LED		LED1206	Osram	LW-M673
3	C1, C2, C3	Capacitor	1µF	0603	Murata	ECJ-1VB1AK05K

Table 1: AAT3119 Evaluation Board Bill of Materials.

Ordering Information

Package	Marking ¹	Part Number (Tape and Reel) ²
SC70JW-8	MUXYY	AAT3119IJS-4.5-T1
SC70JW-8	MVXYY	AAT3119IJS-5.0-T1



All AnalogicTech products are offered in Pb-free packaging. The term “Pb-free” means semiconductor products that are in compliance with current RoHS standards, including the requirement that lead not exceed 0.1% by weight in homogeneous materials. For more information, please visit our website at <http://www.analogictech.com/aboutus/quality.php>.

Package Information

SC70JW-8

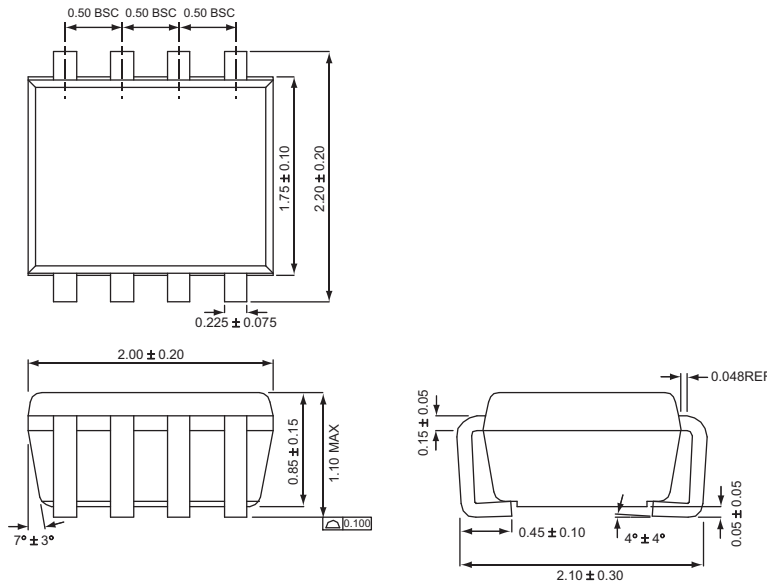

All dimensions in millimeters.

1. XYY = assembly and date code.
2. Sample stock is held on part numbers listed in **BOLD**.

Advanced Analogic Technologies, Inc.
 3230 Scott Boulevard, Santa Clara, CA 95054
 Phone (408) 737-4600
 Fax (408) 737-4611



© Advanced Analogic Technologies, Inc. AnalogicTech cannot assume responsibility for use of any circuitry other than circuitry entirely embodied in an AnalogicTech product. No circuit patent licenses, copyrights, mask work rights, or other intellectual property rights are implied. AnalogicTech reserves the right to make changes to their products or specifications or to discontinue any product or service without notice. Except as provided in AnalogicTech's terms and conditions of sale, AnalogicTech assumes no liability whatsoever, and AnalogicTech disclaims any express or implied warranty relating to the sale and/or use of AnalogicTech products including liability or warranties relating to fitness for a particular purpose, merchantability, or infringement of any patent, copyright or other intellectual property right. In order to minimize risks associated with the customer's applications, adequate design and operating safeguards must be provided by the customer to minimize inherent or procedural hazards. Testing and other quality control techniques are utilized to the extent AnalogicTech deems necessary to support this warranty. Specific testing of all parameters of each device is not necessarily performed. AnalogicTech and the AnalogicTech logo are trademarks of Advanced Analogic Technologies Incorporated. All other brand and product names appearing in this document are registered trademarks or trademarks of their respective holders.