

TOSHIBA CMOS Digital Integrated Circuit Silicon Monolithic

# TC74VHC9164FT, TC74VHC9164FK

## 8-Bit Shift Register (Parallel-IN/ Serial-OUT, Serial -IN/ Parallel -OUT)

The TC74VHC9164 is an ultra-high-speed 8-Bit Shift Register fabricated using silicon-gate CMOS technology. The TC74VHC9164 combines low power consumption of CMOS with Schottky TTL speeds.

The TC74VHC9164 has parallel data inputs/outputs, a serial input and a serial output. It converts parallel data into serial data or vice versa.

When P/S CONT is Low, Q/D1 to Q/D8 are configured as parallel data outputs. At this time, the SI input is serially loaded on the rising edges of CK and unloaded from the Q/D1 to Q/D8 outputs in parallel. When CLR/LOAD input is Low, all flip-flops are asynchronously reset, irrespective of the CK state.

When P/S CONT is High, Q/D1 to Q/D8 are configured as parallel data inputs. At this time, when CLR/LOAD is Low, Q/D1 to Q/D8 latch data in parallel asynchronously from the CK input.

All the inputs have hysteresis between the positive-going and negative-going thresholds. Thus the TC74VHC9164 is capable of squaring up transitions of slowly changing input signals and provides an improved noise immunity.

Additionally, all the inputs have a newly developed protection circuit without a diode returned to VCC. This enables the inputs to be tolerant of up to 5.5 volts even when power supply is down. The input power-down protection capability makes the TC74VHC9164 ideal for a wide range of applications, such as interfacing between different voltages, voltage translation from 5 V to 3 V and battery back-up circuits.

### Features

- High speed:  $f_{max} = 149$  MHz (typ.) at  $V_{CC} = 5$  V
- Low power dissipation:  $I_{CC} = 4$   $\mu$ A (max) at  $T_a = 25^\circ$ C
- Power down protection is provided on all inputs.
- Balanced propagation delays:  $t_{pLH} \approx t_{pHL}$
- Wide operating voltage range:  $V_{CC} (opr) = 2$  to 5.5 V

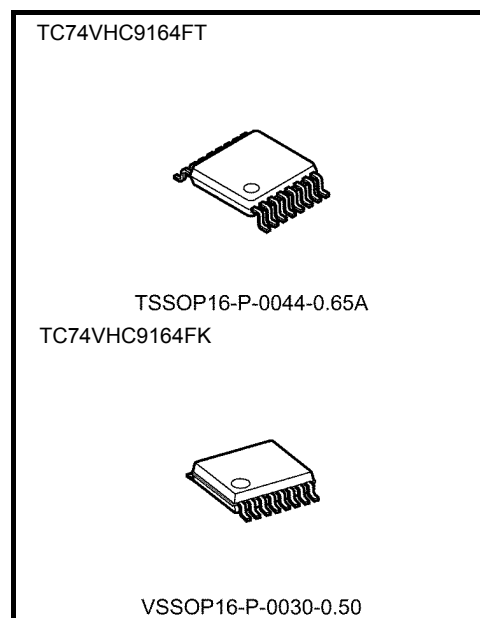

#### Weight

TSSOP16-P-0044-0.65A	: 0.06 g (typ.)
VSSOP16-P-0030-0.50	: 0.02 g (typ.)

## Pin Assignment

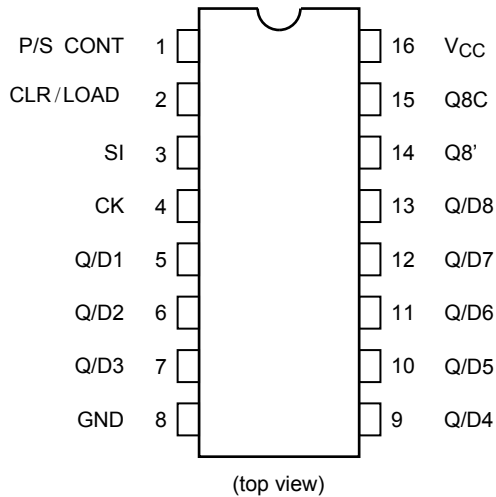

## Truth Table

Inputs				Parallel Outputs/Inputs	Function
P/S CONT	$\overline{\text{CLR/LOAD}}$	SI	CK	Q/D1.....Q/D8	
L	X	X	X	Output- state Parallel Outputs	Q/D1 to Q/D8 are configured as parallel outputs.
L	L	X	X		Shift register is cleared.
L	H	L	$\uparrow$		First stage of S.R. becomes "L". Other stages store the data of previous stage, respectively.
L	H	H	$\uparrow$		First stage of S.R. becomes "H". Other stages store the data of previous stage, respectively.
L	H	X	$\downarrow$		The shift register remains unchanged. The Q8C output keeps the value of the previous flip-flop.
H	X	X	X	Input- state Parallel Inputs	Q/D1 to Q/D8 are configured as parallel inputs.
H	L	X	X		Q/D1 to Q/D8 are latched into the shift register.
H	H	L	$\uparrow$		First stage of S.R. becomes "L". Other stages store the data of previous stage, respectively.
H	H	H	$\uparrow$		First stage of S.R. becomes "H". Other stages store the data of previous stage, respectively.
H	H	X	$\downarrow$		The shift register remains unchanged. The Q8C output keeps the value of the previous flip-flop.

X: Don't care

## System Diagram

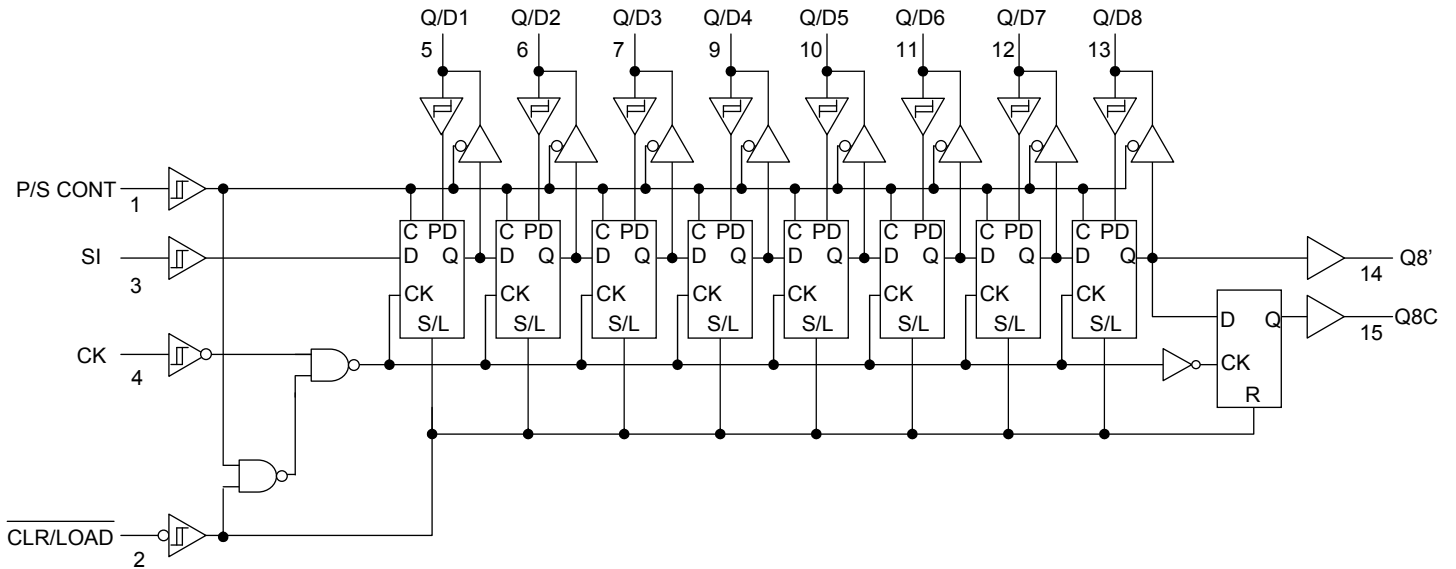

## Timing Chart

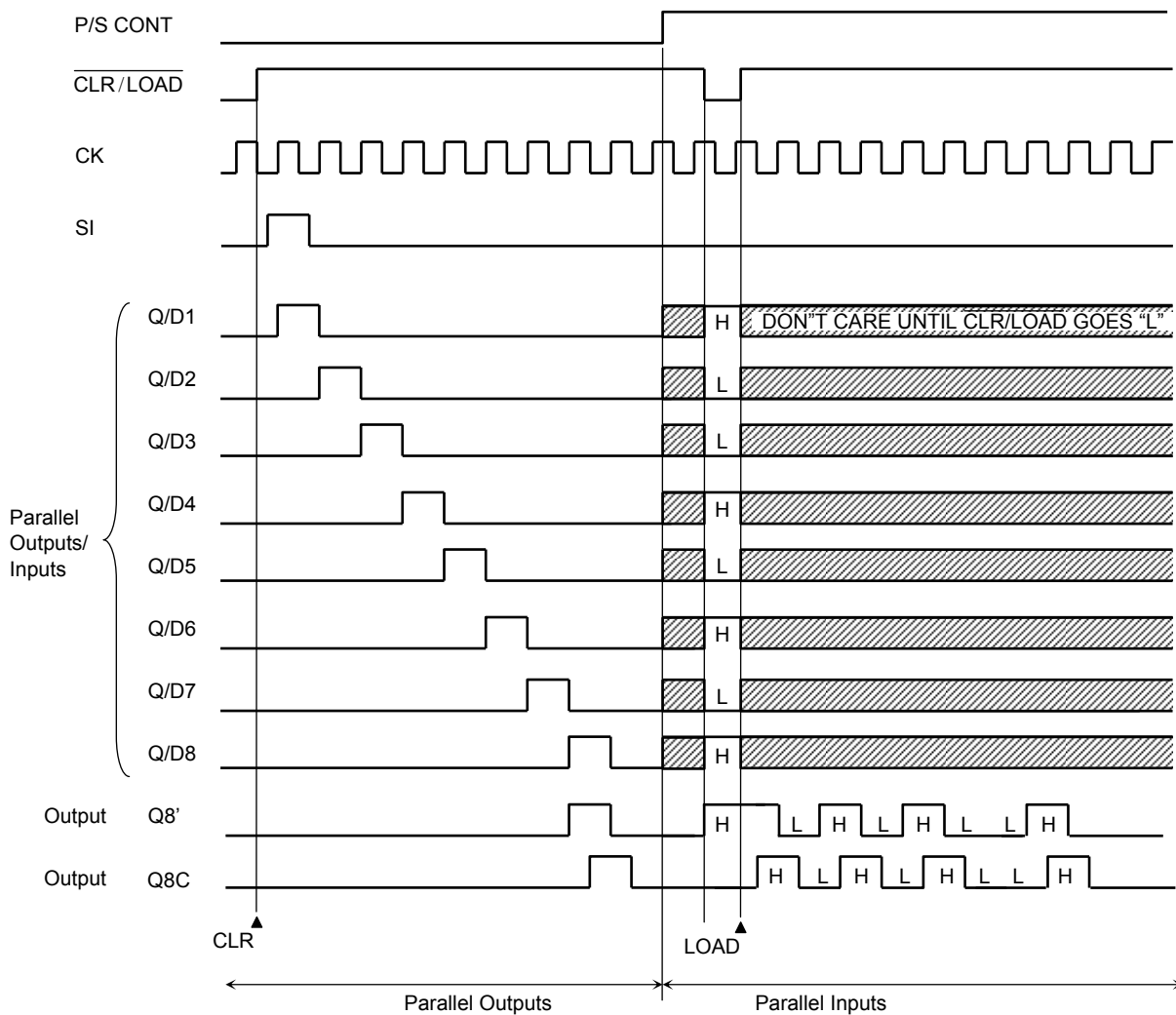

## Absolute Maximum Ratings (Note1)

Characteristics	Symbol	Rating	Unit
Supply voltage range	$V_{CC}$	-0.5 to 7.0	V
DC input voltage	$V_{IN}$	-0.5 to 7.0	V
DC output voltage	$V_{OUT}$	-0.5 to $V_{CC} + 0.5$	V
DC bus I/O voltage (Q/D1 to Q/D8)	$V_{I/O}$	-0.5 to 7.0 (Note2)	V
		-0.5~ $V_{CC} + 0.5$ (Note3)	
Input diode current	$I_{IK}$	-20	mA
Output diode current	$I_{OK}$	$\pm 20$	mA
DC output current	$I_{OUT}$	$\pm 25$	mA
DC $V_{CC}$ /ground current	$I_{CC}$	$\pm 75$	mA
Power dissipation	$P_D$	180	mW
Storage temperature	$T_{stg}$	-65 to 150	$^{\circ}C$

Note1: Exceeding any of the absolute maximum ratings, even briefly, lead to deterioration in IC performance or even destruction.

Using continuously under heavy loads (e.g. the application of high temperature/current/voltage and the significant change in temperature, etc.) may cause this product to decrease in the reliability significantly even if the operating conditions (i.e. operating temperature/current/voltage, etc.) are within the absolute maximum ratings and the operating ranges.

Please design the appropriate reliability upon reviewing the Toshiba Semiconductor Reliability Handbook ("Handling Precautions"/"Derating Concept and Methods") and individual reliability data (i.e. reliability test report and estimated failure rate, etc).

Note2 Output in off-state

Note3 High or low state. IOUT absolute maximum rating must be observed.

## Operating Ranges (Note1)

Characteristics	Symbol	Rating	Unit
Supply voltage	$V_{CC}$	2.0 to 5.5	V
Input voltage	$V_{IN}$	0 to 5.5	V
Output voltage	$V_{OUT}$	0 to $V_{CC}$	V
DC bus I/O voltage (Q/D1 to Q/D8)	$V_{I/O}$	0 to 5.5 (Note2)	V
		0 to $V_{CC}$ (Note3)	
Operating temperature	$T_{opr}$	-40 to 85	$^{\circ}C$

Note1: The operating ranges must be maintained to ensure the normal operation of the device. Unused inputs must be tied to either VCC or GND.

Note2 Output in off-state

Note3 High or low state.

## Electrical Characteristics

### DC Characteristics

Characteristics	Symbol	Test Condition		Ta = 25°C			Ta = -40~85°C		Unit		
				V <sub>CC</sub> (V)	Min	Typ	Max	Min		Max	
Positive threshold voltage	V <sub>P</sub>	—		3.0	—	—	2.20	—	2.20	V	
				4.5	—	—	3.15	—	3.15		
				5.5	—	—	3.85	—	3.85		
Negative threshold voltage	V <sub>N</sub>	—		3.0	0.90	—	—	0.90	—	V	
				4.5	1.35	—	—	1.35	—		
				5.5	1.65	—	—	1.65	—		
Hysteresis voltage	V <sub>H</sub>	—		3.0	0.30	—	1.20	0.30	1.20	V	
				4.5	0.40	—	1.40	0.40	1.40		
				5.5	0.50	—	1.60	0.50	1.60		
High-level output voltage	V <sub>OH</sub>	V <sub>IN</sub> = V <sub>IH</sub> or V <sub>IL</sub>		I <sub>OH</sub> = -50 μA	2.0	1.9	2.0	—	1.9	—	V
					3.0	2.9	3.0	—	2.9	—	
				4.5	4.4	4.5	—	4.4	—		
				I <sub>OH</sub> = -4 mA	3.0	2.58	—	—	2.48	—	
					4.5	3.94	—	—	3.80	—	
Low-level output voltage	V <sub>OL</sub>	V <sub>IN</sub> = V <sub>IH</sub> or V <sub>IL</sub>		I <sub>OL</sub> = 50 μA	2.0	—	0.0	0.1	—	0.1	V
					3.0	—	0.0	0.1	—	0.1	
					4.5	—	0.0	0.1	—	0.1	
				I <sub>OL</sub> = 4 mA	3.0	—	—	0.36	—	0.44	
					4.5	—	—	0.36	—	0.44	
3-state output off-state current (Q/D1 to Q/D8)	I <sub>OZ</sub>	V <sub>IN</sub> = V <sub>IH</sub> or V <sub>IL</sub> V <sub>I/O</sub> = 5.5 V or GND		0 to 5.5	—	—	±0.25	—	±2.5	μA	
Input leakage current	I <sub>IN</sub>	V <sub>IN</sub> = 5.5 V or GND		0 to 5.5	—	—	±0.1	—	±1.0	μA	
Quiescent supply current	I <sub>CC</sub>	V <sub>IN</sub> = V <sub>CC</sub> or GND		5.5	—	—	4.0	—	40.0	μA	

### Timing Requirements (input: $t_r = t_f = 3 \text{ ns}$ )

Characteristics	Symbol	Test Condition	Ta = 25°C		Ta = -40 to 85°C		Unit
			V <sub>CC</sub> (V)	Typ.	Limit	Limit	
Minimum pulse width (CK)	$t_w$ (L)	—	3.3 ± 0.3	—	7.0	8.0	ns
	$t_w$ (H)		5.0 ± 0.5	—	5.0	6.0	
Minimum pulse width ( CLR/LOAD )	$t_w$ (L)	—	3.3 ± 0.3 5.0 ± 0.5	— —	6.0 5.0	7.0 6.0	ns
Minimum set-up time (Q/D1 to Q/D8 – CLR/LOAD )	$t_s$	—	3.3 ± 0.3	—	6.0	7.0	ns
			5.0 ± 0.5	—	5.0	6.0	
Minimum set-up time (SI-CK)	$t_s$	—	3.3 ± 0.3	—	6.0	7.0	ns
			5.0 ± 0.5	—	5.0	5.0	
Minimum hold time (Q/D1 to Q/D8 – CLR/LOAD )	$t_h$	—	3.3 ± 0.3	—	1.0	1.0	ns
			5.0 ± 0.5	—	1.0	1.0	
Minimum hold time (SI-CK)	$t_h$	—	3.3 ± 0.3	—	1.0	1.0	ns
			5.0 ± 0.5	—	1.5	1.5	
Minimum removal time ( CLR/LOAD -CK)	$t_{rem}$	—	3.3 ± 0.3	—	5.0	5.0	ns
			5.0 ± 0.5	—	3.0	3.0	

## AC Characteristics (input: $t_r = t_f = 3$ ns)

Characteristics	Symbol	Test Condition	Ta = 25°C			Ta = -40 to 85°C		Unit		
			V <sub>CC</sub> (V)	C <sub>L</sub> (pF)	Min	Typ.	Max		Min	Max
Propagation delay time (CK – Q/D1 to Q/D8)	t <sub>pLH</sub>	—	3.3 ± 0.3	15	—	9.3	14.7	1.0	16.7	ns
				50	—	12.1	19.0	1.0	21.6	
	5.0 ± 0.5		15	—	6.7	9.7	1.0	11.1		
			50	—	9.1	13.1	1.0	14.9		
Propagation delay time (CK – Q8', Q8C)	t <sub>pLH</sub>	—	3.3 ± 0.3	15	—	9.0	14.4	1.0	16.4	ns
				50	—	11.8	18.6	1.0	21.2	
	5.0 ± 0.5		15	—	6.4	9.4	1.0	10.7		
			50	—	8.7	12.7	1.0	14.5		
Propagation delay time (CLR/LOAD – Q/D1 to Q/D8)	t <sub>pLH</sub>	—	3.3 ± 0.3	15	—	7.9	11.7	1.0	13.4	ns
				50	—	10.2	15.1	1.0	17.2	
	5.0 ± 0.5		15	—	6.2	8.4	1.0	9.6		
			50	—	8.0	11.1	1.0	12.6		
Propagation delay time (CLR/LOAD – Q8', Q8C)	t <sub>pLH</sub>	—	3.3 ± 0.3	15	—	8.0	11.8	1.0	13.5	ns
				50	—	10.3	15.3	1.0	17.5	
	5.0 ± 0.5		15	—	6.2	8.5	1.0	9.7		
			50	—	8.1	11.2	1.0	12.8		
Propagation delay time (Q/D8-Q8)	t <sub>pLH</sub>	—	3.3 ± 0.3	15	—	9.5	15.2	1.0	17.3	ns
				50	—	11.8	18.9	1.0	21.6	
	5.0 ± 0.5		15	—	6.7	9.6	1.0	10.9		
			50	—	8.4	12.2	1.0	13.9		
3-state output enable time (P/S CONT – Q/D1 to Q/D8)	t <sub>pZL</sub>	RL=1kΩ	3.3 ± 0.3	15	—	6.7	10.4	1.0	11.9	ns
				50	—	9.9	15.4	1.0	17.6	
	5.0 ± 0.5		15	—	5.0	7.3	1.0	8.3		
			50	—	7.6	11.0	1.0	12.5		
3-state output disable time (P/S CONT – Q/D1 to Q/D8)	t <sub>pLZ</sub>	RL=1kΩ	3.3 ± 0.3	50	—	10.1	12.8	1.0	13.7	ns
	t <sub>pHZ</sub>		5.0 ± 0.5	50	—	7.8	9.8	1.0	10.6	
Maximum clock frequency	f <sub>max</sub>	—	3.3 ± 0.3	15	68	107	—	59	—	MHz
				50	52	82	—	46	—	
			5.0 ± 0.5	15	103	149	—	90	—	
				50	76	109	—	67	—	
Input capacitance	C <sub>IN</sub>	—			—	4	10	—	10	pF
bus Input capacitance	C <sub>I/O</sub>	—			—	8	—	—	—	pF
Power dissipation capacitance (Note)	C <sub>PD</sub>	P/S CONT=L (Parallel Outputs)			—	102	—	—	—	pF
		P/S CONT=H (Parallel Inputs)			—	34	—	—	—	

Note: C<sub>PD</sub> is defined as the value of the internal equivalent capacitance which is calculated from the operating current consumption without load.

Average operating current can be obtained by the equation:

$$I_{CC (opr)} = C_{PD} \cdot V_{CC} \cdot f_{IN} + I_{CC}$$

Noise Characteristics (input:  $t_r = t_f = 3$  ns)

Characteristics	Symbol	Test Condition	Ta = 25°C			Unit
			V <sub>CC</sub> (V)	Typ.	Max	
Quiet output maximum dynamic V <sub>OL</sub>	V <sub>OLP</sub>	C <sub>L</sub> = 50 pF	5.0	0.6	1.0	V
Quiet output minimum dynamic V <sub>OL</sub>	V <sub>OLV</sub>	C <sub>L</sub> = 50 pF	5.0	-0.5	-1.0	V
Minimum high level dynamic input voltage	V <sub>IHD</sub>	C <sub>L</sub> = 50 pF	5.0	—	3.5	V
Maximum low level dynamic input voltage	V <sub>ILD</sub>	C <sub>L</sub> = 50 pF	5.0	—	1.5	V

**Package Dimensions**

TSSOP16-P-0044-0.65A

Unit: mm

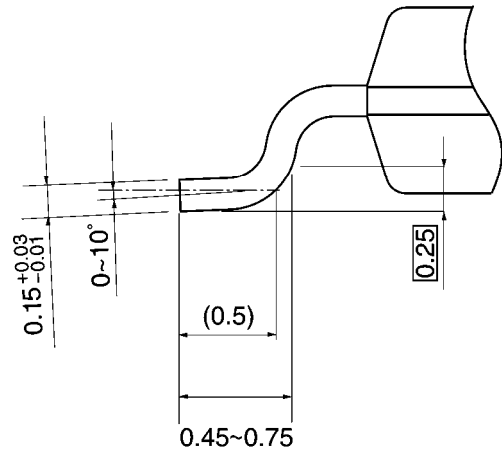
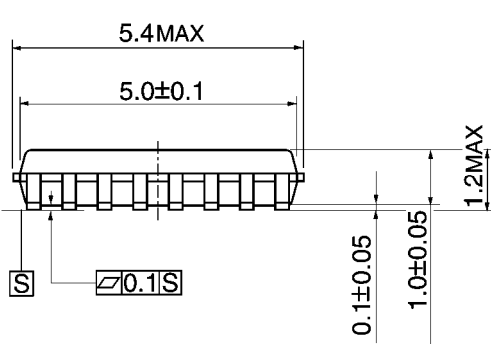
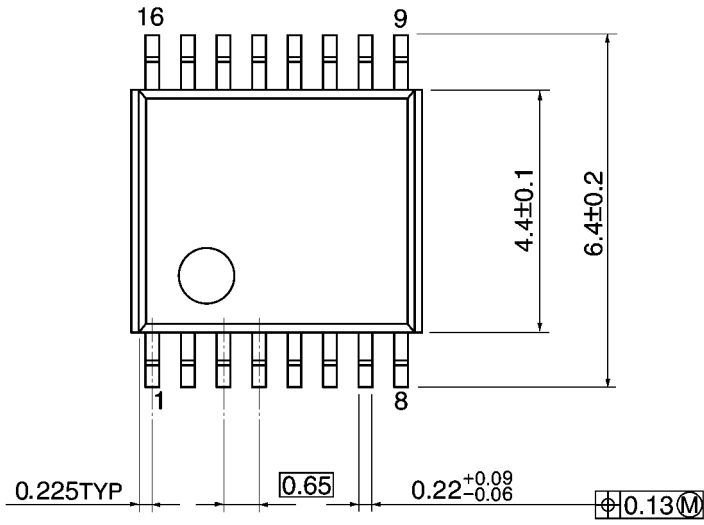

Weight: 0.06 g (typ.)

## Package Dimensions

VSSOP16-P-0030-0.50

Unit: mm

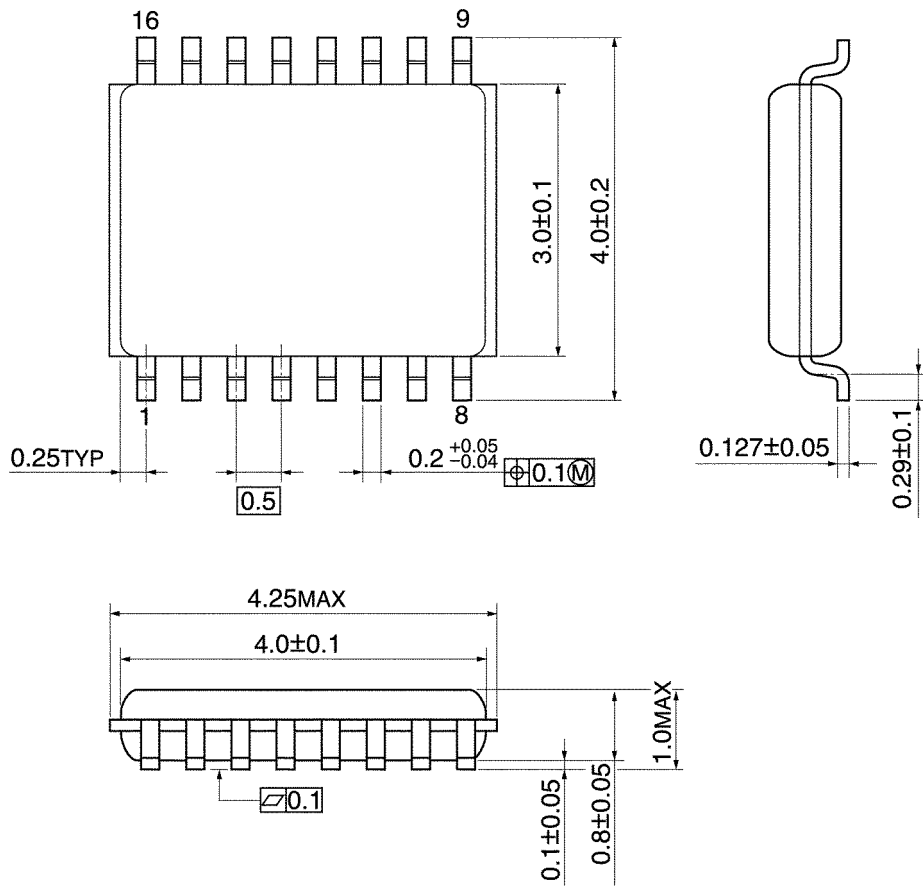

Weight: 0.02 g (typ.)

**RESTRICTIONS ON PRODUCT USE**

- Toshiba Corporation, and its subsidiaries and affiliates (collectively "TOSHIBA"), reserve the right to make changes to the information in this document, and related hardware, software and systems (collectively "Product") without notice.
- This document and any information herein may not be reproduced without prior written permission from TOSHIBA. Even with TOSHIBA's written permission, reproduction is permissible only if reproduction is without alteration/omission.
- Though TOSHIBA works continually to improve Product's quality and reliability, Product can malfunction or fail. Customers are responsible for complying with safety standards and for providing adequate designs and safeguards for their hardware, software and systems which minimize risk and avoid situations in which a malfunction or failure of Product could cause loss of human life, bodily injury or damage to property, including data loss or corruption. Before customers use the Product, create designs including the Product, or incorporate the Product into their own applications, customers must also refer to and comply with (a) the latest versions of all relevant TOSHIBA information, including without limitation, this document, the specifications, the data sheets and application notes for Product and the precautions and conditions set forth in the "TOSHIBA Semiconductor Reliability Handbook" and (b) the instructions for the application with which the Product will be used with or for. Customers are solely responsible for all aspects of their own product design or applications, including but not limited to (a) determining the appropriateness of the use of this Product in such design or applications; (b) evaluating and determining the applicability of any information contained in this document, or in charts, diagrams, programs, algorithms, sample application circuits, or any other referenced documents; and (c) validating all operating parameters for such designs and applications. **TOSHIBA ASSUMES NO LIABILITY FOR CUSTOMERS' PRODUCT DESIGN OR APPLICATIONS.**
- Product is intended for use in general electronics applications (e.g., computers, personal equipment, office equipment, measuring equipment, industrial robots and home electronics appliances) or for specific applications as expressly stated in this document. Product is neither intended nor warranted for use in equipment or systems that require extraordinarily high levels of quality and/or reliability and/or a malfunction or failure of which may cause loss of human life, bodily injury, serious property damage or serious public impact ("Unintended Use"). Unintended Use includes, without limitation, equipment used in nuclear facilities, equipment used in the aerospace industry, medical equipment, equipment used for automobiles, trains, ships and other transportation, traffic signaling equipment, equipment used to control combustions or explosions, safety devices, elevators and escalators, devices related to electric power, and equipment used in finance-related fields. Do not use Product for Unintended Use unless specifically permitted in this document.
- Do not disassemble, analyze, reverse-engineer, alter, modify, translate or copy Product, whether in whole or in part.
- Product shall not be used for or incorporated into any products or systems whose manufacture, use, or sale is prohibited under any applicable laws or regulations.
- The information contained herein is presented only as guidance for Product use. No responsibility is assumed by TOSHIBA for any infringement of patents or any other intellectual property rights of third parties that may result from the use of Product. No license to any intellectual property right is granted by this document, whether express or implied, by estoppel or otherwise.
- **ABSENT A WRITTEN SIGNED AGREEMENT, EXCEPT AS PROVIDED IN THE RELEVANT TERMS AND CONDITIONS OF SALE FOR PRODUCT, AND TO THE MAXIMUM EXTENT ALLOWABLE BY LAW, TOSHIBA (1) ASSUMES NO LIABILITY WHATSOEVER, INCLUDING WITHOUT LIMITATION, INDIRECT, CONSEQUENTIAL, SPECIAL, OR INCIDENTAL DAMAGES OR LOSS, INCLUDING WITHOUT LIMITATION, LOSS OF PROFITS, LOSS OF OPPORTUNITIES, BUSINESS INTERRUPTION AND LOSS OF DATA, AND (2) DISCLAIMS ANY AND ALL EXPRESS OR IMPLIED WARRANTIES AND CONDITIONS RELATED TO SALE, USE OF PRODUCT, OR INFORMATION, INCLUDING WARRANTIES OR CONDITIONS OF MERCHANTABILITY, FITNESS FOR A PARTICULAR PURPOSE, ACCURACY OF INFORMATION, OR NONINFRINGEMENT.**
- Do not use or otherwise make available Product or related software or technology for any military purposes, including without limitation, for the design, development, use, stockpiling or manufacturing of nuclear, chemical, or biological weapons or missile technology products (mass destruction weapons). Product and related software and technology may be controlled under the Japanese Foreign Exchange and Foreign Trade Law and the U.S. Export Administration Regulations. Export and re-export of Product or related software or technology are strictly prohibited except in compliance with all applicable export laws and regulations.
- Please contact your TOSHIBA sales representative for details as to environmental matters such as the RoHS compatibility of Product. Please use Product in compliance with all applicable laws and regulations that regulate the inclusion or use of controlled substances, including without limitation, the EU RoHS Directive. TOSHIBA assumes no liability for damages or losses occurring as a result of noncompliance with applicable laws and regulations.