

TOSHIBA CMOS Digital Integrated Circuit Silicon Monolithic

TC74LVX4051F, TC74LVX4051FT, TC74LVX4051FK TC74LVX4052F, TC74LVX4052FT, TC74LVX4052FK TC74LVX4053F, TC74LVX4053FT, TC74LVX4053FK

TC74LVX4051F/FT/FK

8-Channel Analog Multiplexer/Demultiplexer

TC74LVX4052F/FT/FK

Dual 4-Channel Analog Multiplexer/Demultiplexer

TC74LVX4053F/FT/FK

Triple 2-Channel Analog Multiplexer/Demultiplexer

The TC74LVX4051/4052/4053 are high-speed, low-voltage drive analog multiplexer/demultiplexers using silicon gate CMOS technology. In 3 V and 5 V systems these can achieve high-speed operation with the low power dissipation that is a feature of CMOS.

The TC74LVX4051/4052/4053 offer analog/digital signal selection as well as mixed signals. The 4051 has an 8-channel configuration, the 4052 has an 4-channel × 2 configuration, and the 4053 has a 2-channel × 3 configuration.

The switches for each channel are turned ON by the control pin digital signals.

Although the control signal logical amplitude ($V_{CC} - GND$) is small, the device can perform large-amplitude ($V_{CC} - V_{EE}$) signal switching.

For example, if $V_{CC} = 3\text{ V}$, $GND = 0\text{ V}$, and $V_{EE} = -3\text{ V}$, signals between -3 V and $+3\text{ V}$ can be switched from the logical circuit using a single 3 V power supply.

All control input pins are equipped with a newly developed input protection circuit that avoids the need for a diode on the plus side (forward side from the input to the V_{CC}). As a result, for example, 5 V signals can be permitted on the inputs even when the power supply voltage to the circuits is off. As a result of this input power protection, the TC74LVX4051/4052/4053 can be used in a variety of applications, including in the system which has two power supplies, and in battery backup circuits.

Features

- Low ON resistance: $R_{on} = 22\ \Omega$ (typ.) ($V_{CC} - V_{EE} = 3\text{ V}$)
 $R_{on} = 15\ \Omega$ (typ.) ($V_{CC} - V_{EE} = 6\text{ V}$)
- High speed: $t_{pd} = 3\text{ ns}$ (typ.) ($V_{CC} = 3.0\text{ V}$)
- Low power dissipation: $I_{CC} = 4\ \mu\text{A}$ (max) ($T_a = 25^\circ\text{C}$)
- Input level: $V_{IL} = 0.8\text{ V}$ (max) ($V_{CC} = 3\text{ V}$)
 $V_{IH} = 2.0\text{ V}$ (min) ($V_{CC} = 3\text{ V}$)
- Power down protection is provided on all control inputs
- Pin and function compatible with 74HC4051/4052/4053

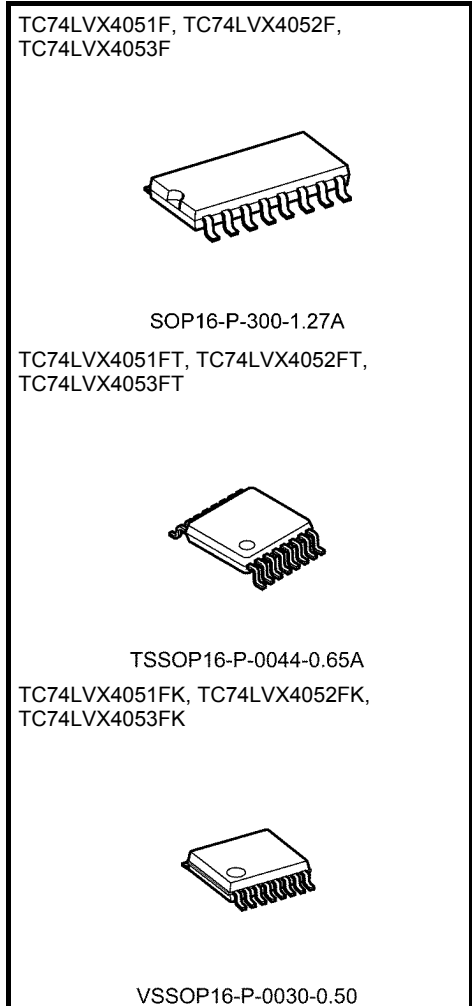

Weight

SOP16-P-300-1.27A	: 0.18 g (typ.)
TSSOP16-P-0044-0.65A	: 0.06 g (typ.)
VSSOP16-P-0030-0.50	: 0.02 g (typ.)

Pin Assignment (top view)

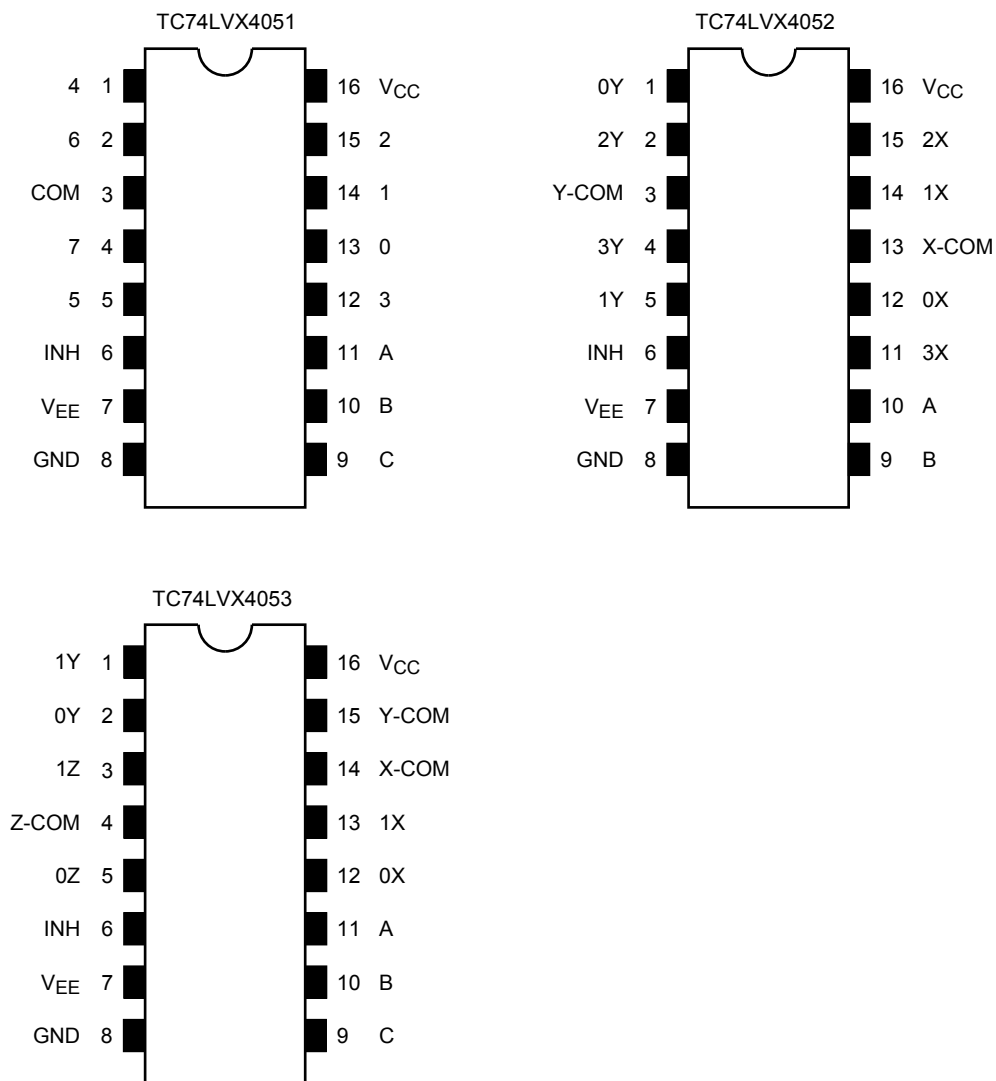

Truth Table

Control Inputs				"ON" Channel		
Inhibit	C*	B	A	TC74LVX4051	TC74LVX4052	TC74LVX4053
L	L	L	L	0	0X, 0Y	0X, 0Y, 0Z
L	L	L	H	1	1X, 1Y	1X, 0Y, 0Z
L	L	H	L	2	2X, 2Y	0X, 1Y, 0Z
L	L	H	H	3	3X, 3Y	1X, 1Y, 0Z
L	H	L	L	4	—	0X, 0Y, 1Z
L	H	L	H	5	—	1X, 0Y, 1Z
L	H	H	L	6	—	0X, 1Y, 1Z
L	H	H	H	7	—	1X, 1Y, 1Z
H	X	X	X	None	None	None

X: Don't care, *: Except TC74LVX4052

System Diagram

TC74LVX4051

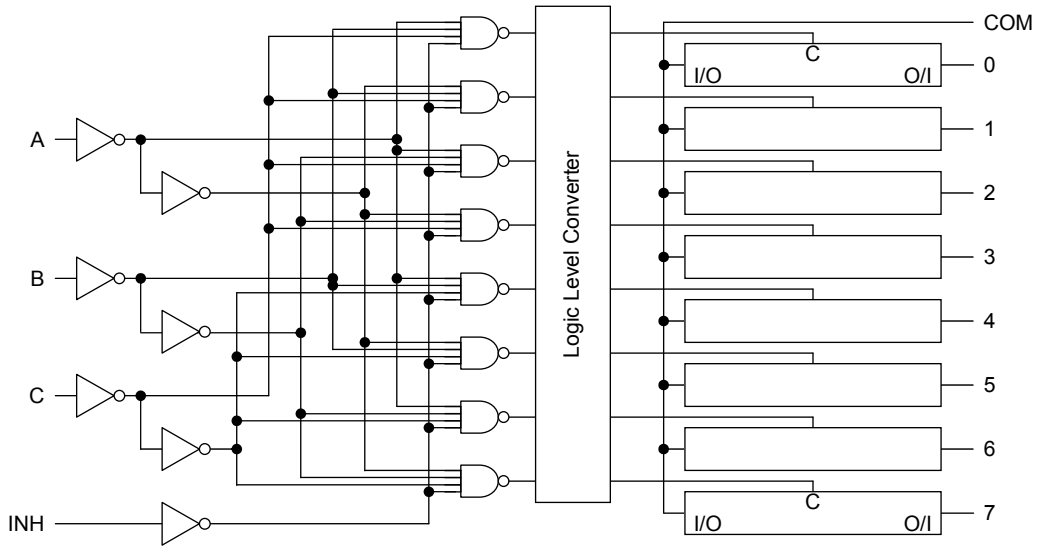

TC74LVX4052

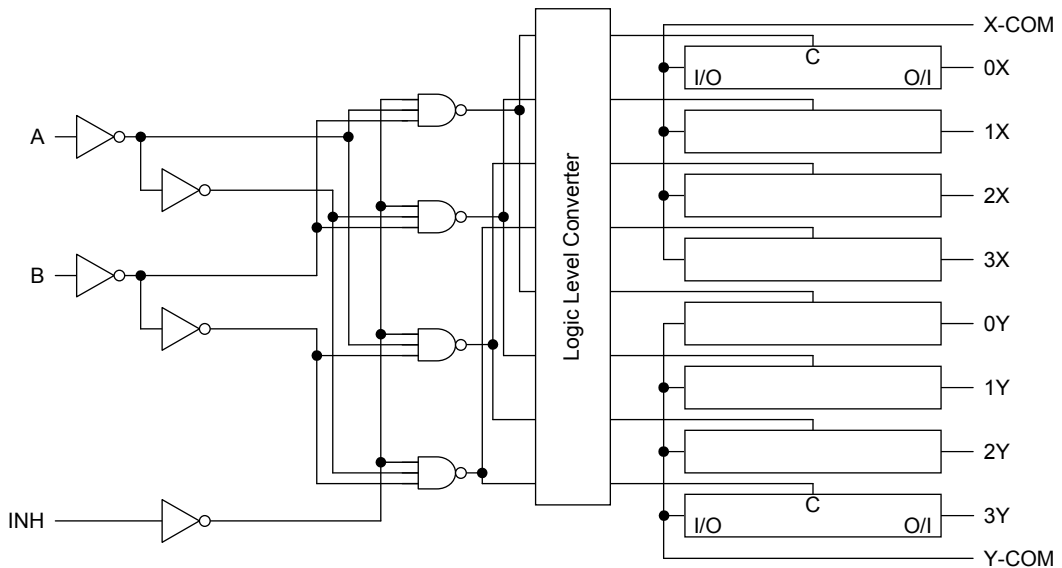

TC74LVX4053

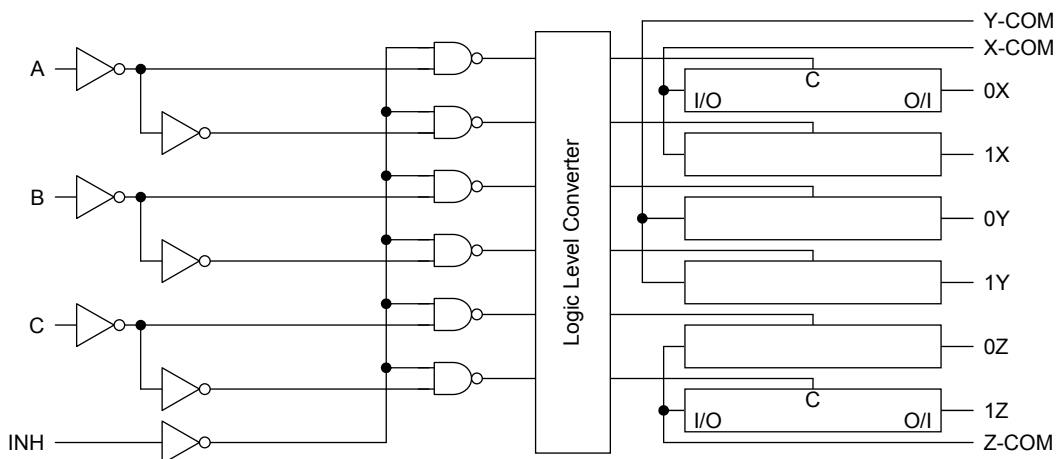

Absolute Maximum Ratings (Note)

Characteristics	Symbol	Rating	Unit
Power supply voltage	V_{CC}	-0.5 to 7.0	V
	V_{CC} to V_{EE}	-0.5 to 7.0	
Control input voltage	V_{IN}	-0.5 to 7.0	V
Switch I/O voltage	$V_{I/O}$	$V_{EE} - 0.5$ to $V_{CC} + 0.5$	V
Input diode current	I_{IK}	-20	mA
I/O diode current	I_{IOK}	± 20	mA
Switch through current	I_T	± 25	mA
DC V_{CC} or ground current	I_{CC}	± 50	mA
Power dissipation	P_D	180	mW
Storage temperature	T_{stg}	-65 to 150	$^{\circ}C$

Note: Exceeding any of the absolute maximum ratings, even briefly, lead to deterioration in IC performance or even destruction.

Using continuously under heavy loads (e.g. the application of high temperature/current/voltage and the significant change in temperature, etc.) may cause this product to decrease in the reliability significantly even if the operating conditions (i.e. operating temperature/current/voltage, etc.) are within the absolute maximum ratings and the operating ranges.

Please design the appropriate reliability upon reviewing the Toshiba Semiconductor Reliability Handbook ("Handling Precautions"/"Derating Concept and Methods") and individual reliability data (i.e. reliability test report and estimated failure rate, etc).

Operating Ranges (Note)

Characteristics	Symbol	Rating	Unit
Power supply voltage	V_{CC}	2 to 6	V
	V_{EE}	-4 to 0	
	V_{CC} to V_{EE}	2 to 6	
Input voltage	V_{IN}	0 to 6.0	V
Switch I/O voltage	$V_{I/O}$	V_{EE} to V_{CC}	V
Operating temperature	T_{opr}	-40 to 85	$^{\circ}C$
Input rise and fall time	dt/dv	0 to 100 ($V_{CC} = 3.3 \pm 0.3$ V)	ns/V
		0 to 20 ($V_{CC} = 5 \pm 0.5$ V)	

Note: The operating ranges must be maintained to ensure the normal operation of the device. Unused inputs must be tied to either V_{CC} or GND.

Electrical Characteristics

DC Electrical Characteristics

Characteristics		Symbol	Test Condition	Ta = 25°C			Ta = -40 to 85°C		Unit			
				V _{EE} (V)	V _{CC} (V)	Min	Typ.	Max		Min	Max	
Input voltage	High-level	V _{IH}	—		2.0	1.5	—	—	1.5	—	V	
					3.0	2.0	—	—	2.0	—		
					4.5	3.15	—	—	3.15	—		
					6.0	4.2	—	—	4.2	—		
	Low-level	V _{IL}	—			2.0	—	—	0.5	—		0.5
						3.0	—	—	0.8	—		0.8
						4.5	—	—	1.35	—		1.35
						6.0	—	—	1.8	—		1.8
ON resistance	R _{ON}	V _{IN} = V _{IL} or V _{IH} V _{I/O} = V _{CC} to V _{EE} I _{I/O} = 2 mA	GND		2.0	—	200	—	—	—	Ω	
					3.0	—	45	86	—	108		
					4.5	—	24	37	—	46		
					-3.0	3.0	—	17	26	—		33
			GND		2.0	—	28	73	—	84		
					3.0	—	22	38	—	44		
					4.5	—	17	27	—	31		
					-3.0	3.0	—	15	24	—		28
Difference of ON resistance between switches	ΔR _{ON}	V _{IN} = V _{IL} or V _{IH} V _{I/O} = V _{CC} to V _{EE} I _{I/O} = 2 mA	GND		2.0	—	10	25	—	35	Ω	
					3.0	—	5	15	—	20		
					4.5	—	5	13	—	18		
					-3.0	3.0	—	5	10	—		15
Input/Output leakage current (switch OFF)	I _{OFF}	V _{OS} = V _{CC} or GND V _{IS} = GND to V _{CC} V _{IN} = V _{IL} or V _{IH}	GND		3.0	—	—	±0.25	—	±2.5	μA	
					-3.0	3.0	—	—	±0.5	—		±5.0
Input/Output leakage current (switch ON, output open)	I _{IN}	V _{OS} = V _{CC} or GND V _{IN} = V _{IL} or V _{IH}	GND		3.0	—	—	±0.25	—	±2.5	μA	
					-3.0	3.0	—	—	±0.5	—		±5.0
Control input current	I _{IN}	V _{IN} = V _{CC} or GND	GND		6.0	—	—	±0.1	—	±0.1	μA	
Quiescent supply current	I _{CC}	V _{IN} = V _{CC} or GND	GND		3.0	—	—	4.0	—	40.0	μA	
					-3.0	3.0	—	—	8.0	—		80.0

AC Electrical Characteristics (C_L = 50 pF, Input: t_r = t_f = 3 ns, GND = 0 V)

Characteristics	Symbol	Test Condition	Ta = 25°C			Ta = -40 to 85°C		Unit			
			V _{EE} (V)	V _{CC} (V)	Min	Typ.	Max		Min	Max	
Phase difference between input and output	φ _{I/O}	All types	GND	2.0	—	3.2	6.0	—	6.9	ns	
			GND	3.0	—	1.8	3.0	—	3.5		
			GND	4.5	—	1.3	1.8	—	2.1		
			-3.0	3.0	—	1.1	1.3	—	1.5		
Output enable time	t _{pZL} t _{pZH}	Figure 1 (Note 1)	GND	2.0	—	9.0	17	—	20	ns	
			GND	3.0	—	5.7	9.0	—	11		
			GND	4.5	—	4.5	6.0	—	7.0		
			-3.0	3.0	—	5.8	8.0	—	10		
Output disable time	t _{pLZ} t _{pHZ}	Figure 1 (Note 1)	GND	2.0	—	13.5	21	—	25	ns	
			GND	3.0	—	11.3	15	—	18		
			GND	4.5	—	10.3	12	—	14		
			-3.0	3.0	—	10.9	13	—	15		
Control input capacitance	C _{in}	All types (Note 2)	—	—	—	5	10	—	10	pF	
COMMON terminal capacitance	C _{IS}	4051	Figure 2 (Note 2)	-3.0	3.0	—	11	25	—	25	pF
		4052					9	20		20	
		4053					7	15		15	
SWITCH terminal capacitance	C _{OS}	4051	Figure 2 (Note 2)	-3.0	3.0	—	6	13	—	13	pF
		4052					6	13		13	
		4053					6	13		13	
Feedthrough capacitance	C _{IOS}	4051	Figure 2 (Note 2)	-3.0	3.0	—	3	6	—	6	pF
		4052					3	6		6	
		4053					3	6		6	
Power dissipation capacitance	C _{PD}	4051	Figure 2 (Note 3)	GND	6.0	—	14	—	—	—	pF
		4052					24				
		4053					18				

Note 1: R_L = 1 kΩ

Note 2: C_{in}, C_{IS}, C_{OS} and C_{IOS} are guaranteed by the design.

Note 3: C_{PD} is defined as the value of the internal equivalent capacitance of IC which is calculated from the operating current consumption without load.

Average operating current can be obtained by the equation:

$$I_{CC(opr)} = C_{PD} \cdot V_{CC} \cdot f_{IN} + I_{CC}$$

Analog Switch Characteristics (GND = 0 V, Ta = 25°C) (Note)

Characteristics	Symbol	Test Condition		Typ.	Unit		
		V_{EE} (V)	V_{CC} (V)				
Sine Wave Distortion (T.H.D)	—	$R_L = 10\text{ k}\Omega$, $C_L = 50\text{ pF}$, $f_{IN} = 1\text{ kHz}$	$V_{IN} = 2.0\text{ V}_{p-p}$	0	3.0	0.100	%
			$V_{IN} = 4.0\text{ V}_{p-p}$	0	4.5	0.030	
			$V_{IN} = 6.0\text{ V}_{p-p}$	-0.3	3.0	0.020	
Frequency response (switch ON)	f_{max}	$R_L = 50\ \Omega$, $C_L = 10\text{ pF}$, $f_{IN} = 1\text{ MHz}$, sine wave Figure 3	4051	0	3.0	150	MHz
			4052			180	
			4053			200	
			4051	0	4.5	150	
			4052			180	
			4053			200	
			4051	-3.0	3.0	150	
			4052			180	
			4053			200	
Feed through attenuation (switch OFF)	—	V_{IN} is centered at $(V_{CC} - V_{EE})/2$. Adjust input for 0dBm. $R_L = 600\ \Omega$, $C_L = 50\text{ pF}$, $f_{IN} = 1\text{ MHz}$, sine wave Figure 4	0	3.0	-45	dB	
			0	4.5	-45		
			-3.0	3.0	-45		
			0	3.0	-60		
			0	4.5	-60		
			-3.0	3.0	-60		
Crosstalk (control input to signal output)	—	$R_L = 600\ \Omega$, $C_L = 50\text{ pF}$, $f_{IN} = 1\text{ MHz}$, square wave ($t_r = t_f = 6\text{ ns}$) Figure 5	0	3.0	90	mV	
			0	4.5	150		
			-3.0	3.0	120		
Crosstalk (between any switches)	—	Adjust V_{IN} to obtain 0dBm at input. $R_L = 600\ \Omega$, $C_L = 50\text{ pF}$, $f_{IN} = 1\text{ MHz}$, sine wave Figure 6	0	3.0	-45	dB	
			0	4.5	-45		
			-3.0	3.0	-45		

Note: These characteristics are determined by design of devices.

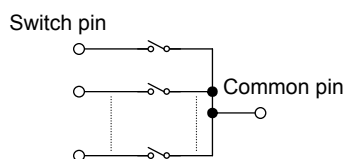

AC Test Circuit

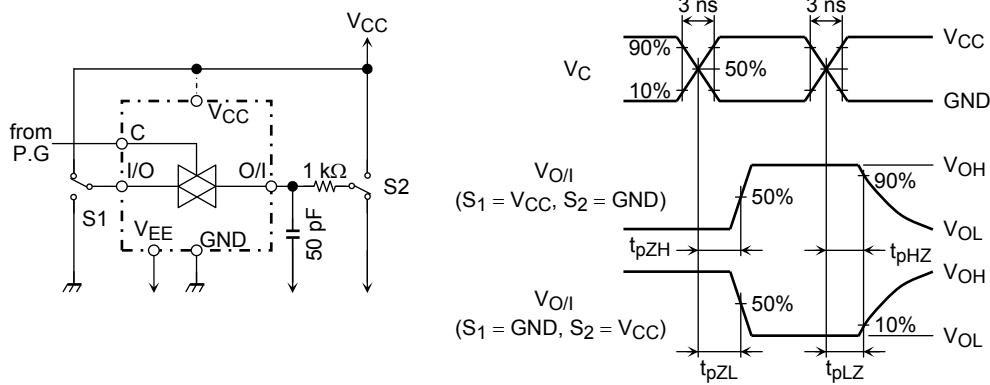

Figure 1 t_{pLZ} , t_{pHZ} , t_{pZL} , t_{pZH}

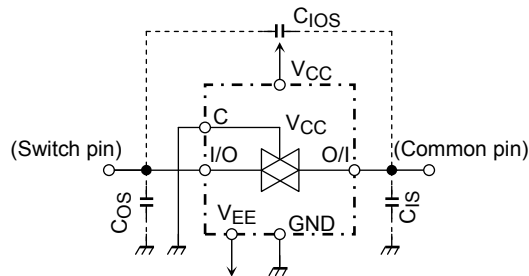

Figure 2 C_{10S} , C_{IS} , C_{OS}

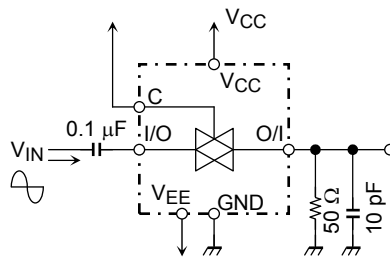

Figure 3 Frequency Response (switch on)

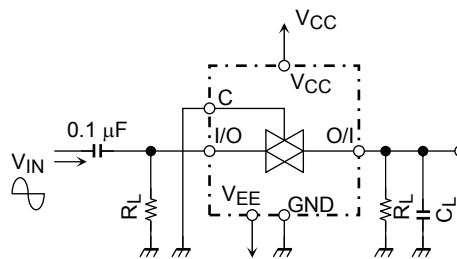

Figure 4 Feedthrough

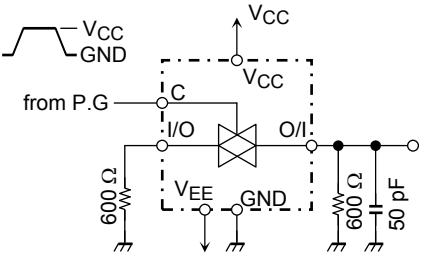

Figure 5 Cross Talk (control input to output signal)

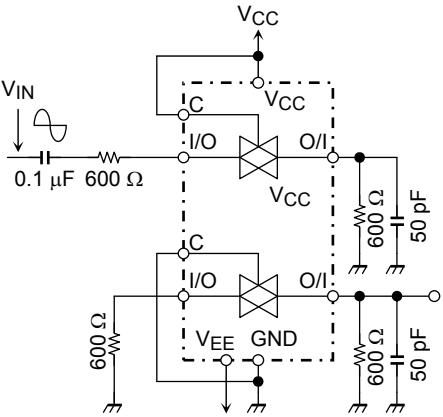
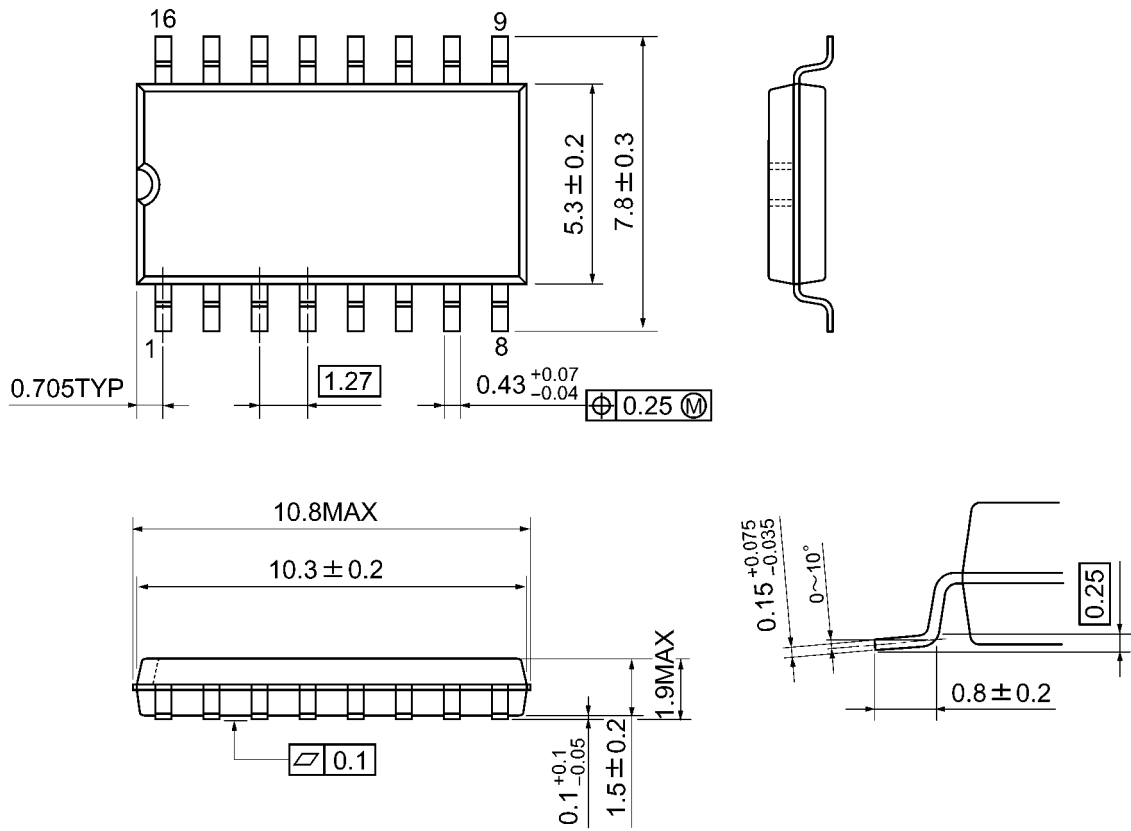

Figure 6 Cross Talk (between any two switches)

Package Dimensions

SOP16-P-300-1.27A

Unit: mm



Weight: 0.18 g (typ.)

Package Dimensions

TSSOP16-P-0044-0.65A

Unit: mm

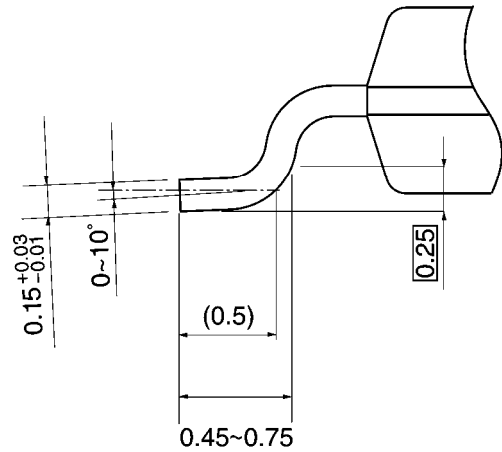
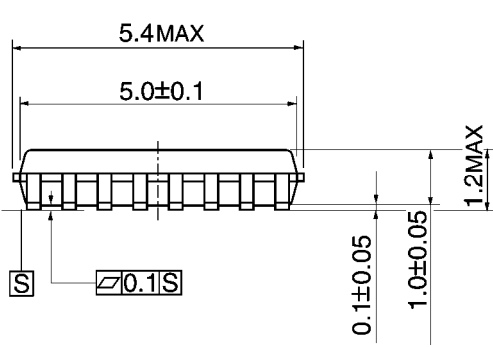
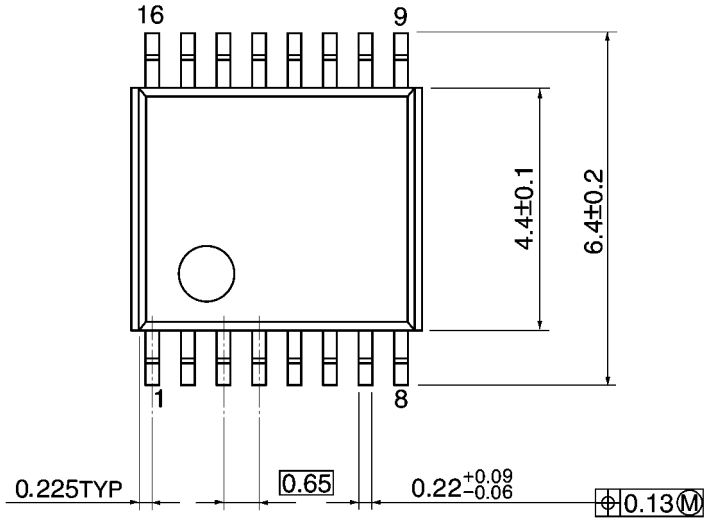

Weight: 0.06 g (typ.)

Package Dimensions

VSSOP16-P-0030-0.50

Unit: mm

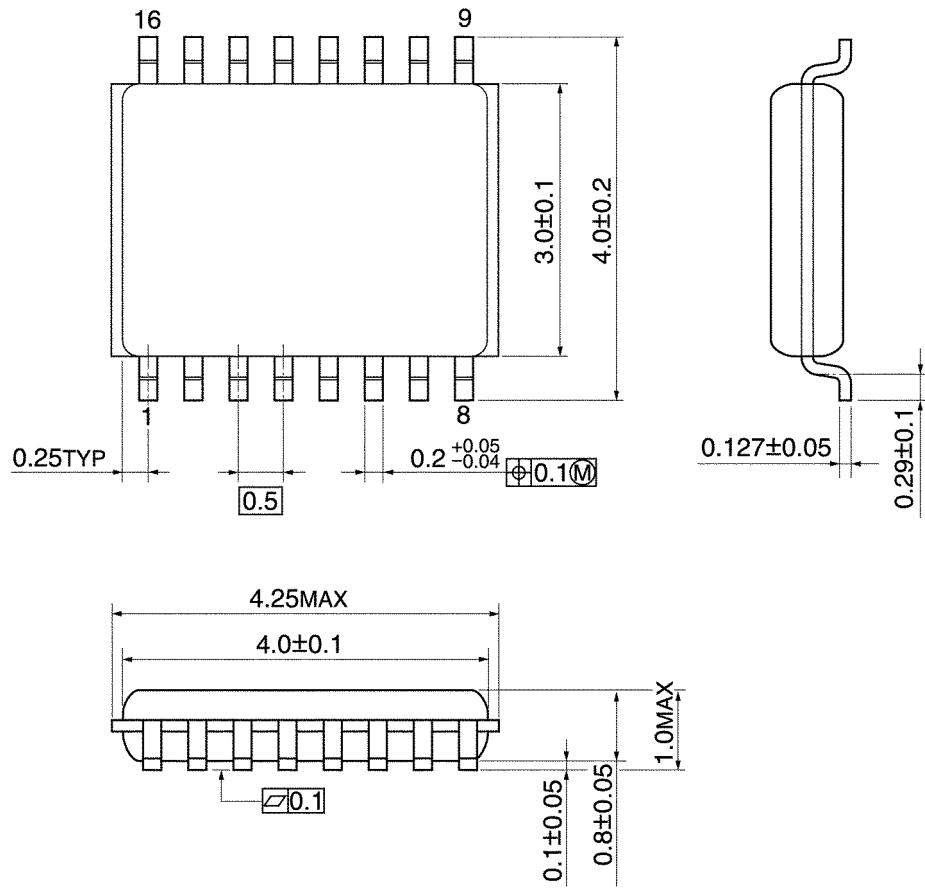

Weight: 0.02 g (typ.)

RESTRICTIONS ON PRODUCT USE

- Toshiba Corporation, and its subsidiaries and affiliates (collectively "TOSHIBA"), reserve the right to make changes to the information in this document, and related hardware, software and systems (collectively "Product") without notice.
- This document and any information herein may not be reproduced without prior written permission from TOSHIBA. Even with TOSHIBA's written permission, reproduction is permissible only if reproduction is without alteration/omission.
- Though TOSHIBA works continually to improve Product's quality and reliability, Product can malfunction or fail. Customers are responsible for complying with safety standards and for providing adequate designs and safeguards for their hardware, software and systems which minimize risk and avoid situations in which a malfunction or failure of Product could cause loss of human life, bodily injury or damage to property, including data loss or corruption. Before creating and producing designs and using, customers must also refer to and comply with (a) the latest versions of all relevant TOSHIBA information, including without limitation, this document, the specifications, the data sheets and application notes for Product and the precautions and conditions set forth in the "TOSHIBA Semiconductor Reliability Handbook" and (b) the instructions for the application that Product will be used with or for. Customers are solely responsible for all aspects of their own product design or applications, including but not limited to (a) determining the appropriateness of the use of this Product in such design or applications; (b) evaluating and determining the applicability of any information contained in this document, or in charts, diagrams, programs, algorithms, sample application circuits, or any other referenced documents; and (c) validating all operating parameters for such designs and applications. **TOSHIBA ASSUMES NO LIABILITY FOR CUSTOMERS' PRODUCT DESIGN OR APPLICATIONS.**
- Product is intended for use in general electronics applications (e.g., computers, personal equipment, office equipment, measuring equipment, industrial robots and home electronics appliances) or for specific applications as expressly stated in this document. Product is neither intended nor warranted for use in equipment or systems that require extraordinarily high levels of quality and/or reliability and/or a malfunction or failure of which may cause loss of human life, bodily injury, serious property damage or serious public impact ("Unintended Use"). Unintended Use includes, without limitation, equipment used in nuclear facilities, equipment used in the aerospace industry, medical equipment, equipment used for automobiles, trains, ships and other transportation, traffic signaling equipment, equipment used to control combustions or explosions, safety devices, elevators and escalators, devices related to electric power, and equipment used in finance-related fields. Do not use Product for Unintended Use unless specifically permitted in this document.
- Do not disassemble, analyze, reverse-engineer, alter, modify, translate or copy Product, whether in whole or in part.
- Product shall not be used for or incorporated into any products or systems whose manufacture, use, or sale is prohibited under any applicable laws or regulations.
- The information contained herein is presented only as guidance for Product use. No responsibility is assumed by TOSHIBA for any infringement of patents or any other intellectual property rights of third parties that may result from the use of Product. No license to any intellectual property right is granted by this document, whether express or implied, by estoppel or otherwise.
- **ABSENT A WRITTEN SIGNED AGREEMENT, EXCEPT AS PROVIDED IN THE RELEVANT TERMS AND CONDITIONS OF SALE FOR PRODUCT, AND TO THE MAXIMUM EXTENT ALLOWABLE BY LAW, TOSHIBA (1) ASSUMES NO LIABILITY WHATSOEVER, INCLUDING WITHOUT LIMITATION, INDIRECT, CONSEQUENTIAL, SPECIAL, OR INCIDENTAL DAMAGES OR LOSS, INCLUDING WITHOUT LIMITATION, LOSS OF PROFITS, LOSS OF OPPORTUNITIES, BUSINESS INTERRUPTION AND LOSS OF DATA, AND (2) DISCLAIMS ANY AND ALL EXPRESS OR IMPLIED WARRANTIES AND CONDITIONS RELATED TO SALE, USE OF PRODUCT, OR INFORMATION, INCLUDING WARRANTIES OR CONDITIONS OF MERCHANTABILITY, FITNESS FOR A PARTICULAR PURPOSE, ACCURACY OF INFORMATION, OR NONINFRINGEMENT.**
- Do not use or otherwise make available Product or related software or technology for any military purposes, including without limitation, for the design, development, use, stockpiling or manufacturing of nuclear, chemical, or biological weapons or missile technology products (mass destruction weapons). Product and related software and technology may be controlled under the Japanese Foreign Exchange and Foreign Trade Law and the U.S. Export Administration Regulations. Export and re-export of Product or related software or technology are strictly prohibited except in compliance with all applicable export laws and regulations.
- Please contact your TOSHIBA sales representative for details as to environmental matters such as the RoHS compatibility of Product. Please use Product in compliance with all applicable laws and regulations that regulate the inclusion or use of controlled substances, including without limitation, the EU RoHS Directive. TOSHIBA assumes no liability for damages or losses occurring as a result of noncompliance with applicable laws and regulations.