

## General Description

The AAT3105 is a charge-pump based, current-source white LED driver capable of driving one to four LEDs up to 30mA, each. It automatically switches between 1x mode and 2x mode to maintain the highest efficiency and optimal LED current matching.

The AAT3105 charge pump's 1x mode (bypass mode) has very low resistance, allowing LED current regulation to be maintained with input supply voltage approaching the LED forward voltage.

LED brightness is controlled using a universal PWM interface. The AAT3105 is available in a Pb-free, 2x2mm 10-lead SC70JW-10 package

## Features

- Drives up to 4 LEDs at up to 30mA each
- Automatic Switching Between 1x and 2x Modes
- 0.85MHz Switching Frequency
- Linear LED Output Current Control
- Universal PWM Interface
- $\pm 10\%$  LED Output Current Accuracy
- $\pm 3\%$  LED Output Current Matching
- Low-current Shutdown Mode
- Built-in Thermal Protection
- Automatic Soft-start
- Available in 2x2mm SC70JW-10 Package

## Applications

- Cell Phones
- Digital Still Cameras
- MP3 Players
- Personal Data Assistants (PDAs)

## Typical Application

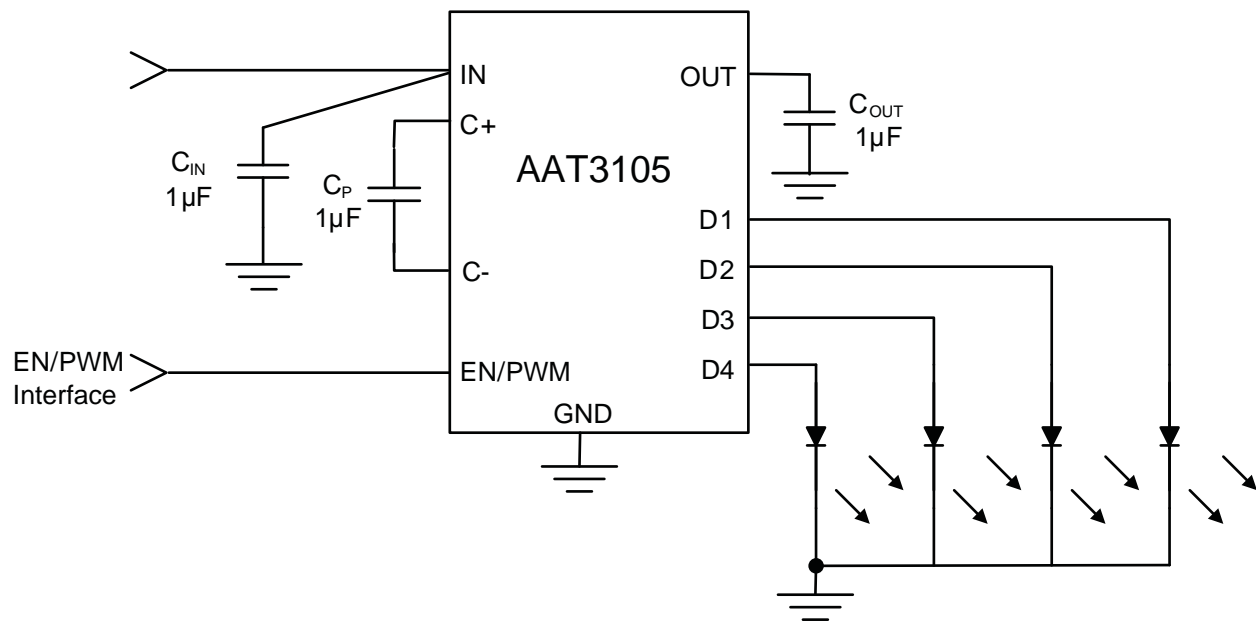

## Pin Description

Pin #	Name	Function
1	D2	LED2 Current Source Output. D2 is the output of LED2 current source. Connect LED2's anode to D2 and its cathode to GND.
2	D1	LED1 Current Source Output. D1 is the output of LED1 current source. Connect LED1's anode to D1 and its cathode to GND.
3	OUT	Charge Pump Output. OUT is the output of the charge pump. Bypass OUT to GND with a 1µF or larger ceramic capacitor.
4	C-	Charge Pump Capacitor Negative Node.
5	C+	Charge Pump Capacitor Positive Node. Connect a 1µF ceramic capacitor between C+ and C-.
6	GND	Analog Ground. Connect this pin to the system's analog ground plane.
7	EN/PWM	LED Enable and control input. EN/PWM is the ON/OFF control for the LED and the PWM input for the AAT3105 to control the LED brightness.
8	IN	Power source input. Connect IN to the power source, typically the battery. Bypass IN to GND with a 1µF or larger ceramic capacitor.
9	D4	LED4 Current Source Output. D4 is the output of LED4 current source. Connect LED4's anode to D4 and its cathode to GND.
10	D3	LED3 Current Source Output. D3 is the output of LED3 current source. Connect LED3's anode to D3 and its cathode to GND.

## Pin Configuration

**SC70JW-10**  
(Top View)

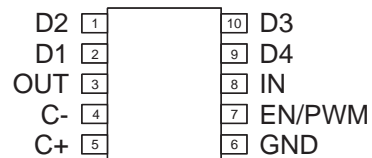

## Absolute Maximum Ratings<sup>1</sup>

Symbol	Description	Value	Units
V <sub>IN</sub>	IN, C+, C-, OUT, D1, D2, D3, and D4 Pin Voltages to GND	-0.3 to 6.0	V
V <sub>EN</sub>	EN/PWM Pin Voltage to GND	-0.3 to V <sub>IN</sub> + 0.3	V
T <sub>S</sub>	Storage Temperature Range	-65 to 150	°C
T <sub>J</sub>	Operating Junction Temperature Range	-40 to 150	°C
T <sub>LEAD</sub>	Maximum Soldering Temperature (at leads, 10 sec)	300	°C

## Thermal Information

Symbol	Description	Value	Units
P <sub>D</sub>	Maximum Power Dissipation <sup>2,3</sup>	625	mW
θ <sub>JA</sub>	Maximum Thermal Resistance <sup>3</sup>	160	°C/W

1. Stresses above those listed in Absolute Maximum Ratings may cause permanent damage to the device. Functional operation at conditions other than the operating conditions specified is not implied. Only one Absolute Maximum Rating should be applied at any one time.

2. Mounted on an FR4 circuit board.

3. Derate 6.25mW/°C above 40°C ambient temperature.

## Electrical Characteristics

IN = EN = 3.6V, C<sub>IN</sub> = 1μF, C<sub>OUT</sub> = 1μF, C<sub>P</sub> = 1μF, T<sub>A</sub> = -40°C to 85°C unless otherwise noted. Typical values are at T<sub>A</sub> = 25°C.

Symbol	Description	Conditions	Min	Typ	Max	Units
<b>Input Power Supply</b>						
IN	Input Voltage Range		2.7		5.5	V
I <sub>IN</sub>	Input Operating Current	IN = 5.5V, EN = IN, VD1 = VD2 = VD3 = VD4 = 0V		6.1	8.0	mA
		IN = 5.5V, EN = IN, I <sub>D1</sub> = I <sub>D2</sub> = I <sub>D3</sub> = I <sub>D4</sub> = FS, V <sub>D1</sub> = V <sub>D2</sub> = V <sub>D3</sub> = V <sub>D4</sub> = IN - 1.5V, Excluding I <sub>DN</sub> current		3.0	4.6	mA
		Operating, I <sub>D1</sub> = I <sub>D2</sub> = I <sub>D3</sub> = I <sub>D4</sub> = OPEN		6.0	8.0	mA
I <sub>IN(SHDN)</sub>	Input Shutdown Current	EN/PWM = GND			1	μA
<b>Charge Pump Section</b>						
I <sub>OUT</sub>	OUT Maximum Output Current			150		mA
V <sub>OUT</sub>	Charge Pump Output Voltage	When charge pump is on		5		V
f <sub>OSC</sub>	Charge Pump Oscillator Frequency		0.60	0.85	1.05	MHz
V <sub>IN_(TH)</sub>	Charge Pump Mode Hysteresis	I <sub>D1</sub> = I <sub>D2</sub> = I <sub>D3</sub> = I <sub>D4</sub> = 30mA		150	250	mV
t <sub>OUT</sub>	LED Output Current Start-up Time	EN/PWM = IN		110		μs
<b>LED Current Source Outputs</b>						
I <sub>D_(MAX)</sub>	D1 - D4 Current Accuracy	Duty Cycle = 100%	27	30	33	mA
ΔI <sub>D_(MAX)</sub>	D1 - D4 Current Matching	Duty Cycle = 100%, V <sub>IN</sub> - V <sub>F</sub> = 1.5V	-3		3	%
I <sub>D_(10%)</sub>	D1 - D4 Current Accuracy	Duty Cycle = 10%, V <sub>IN</sub> - V <sub>F</sub> = 1.5V		3.2		mA
V <sub>D_(TH)</sub>	D1- D4 Charge Pump Mode Transition Threshold	I <sub>D1</sub> = I <sub>D2</sub> = I <sub>D3</sub> = I <sub>D4</sub> = 30mA, V <sub>IN</sub> - V <sub>D1</sub> is measured.		380		mV
<b>EN/ PWM Current Control</b>						
V <sub>ENH</sub>	EN/PWM Input High Threshold Voltage		1.4			V
V <sub>ENL</sub>	EN/PWM Input Low Threshold Voltage				0.4	V
I <sub>EN(LKG)</sub>	EN/PWM Input Leakage Current	EN/PWM = IN = 5V	-1		1	μA
t <sub>PWM(ON)</sub>	PWM Control Turn-on Delay			2		μs
t <sub>EN/PWM</sub>	EN/PWM Input OFF Timeout		0.15		1	ms
f <sub>PWM</sub>	PWM Control Frequency	Duty cycle = 80%			50	kHz

## Typical Characteristics

$V_{IN} = 3.6V$ ,  $C_{IN} = C_{OUT} = C_P = 1\mu F$ ;  $T_A = 25^\circ C$ , unless otherwise noted.

**Shutdown Current vs. Temperature**

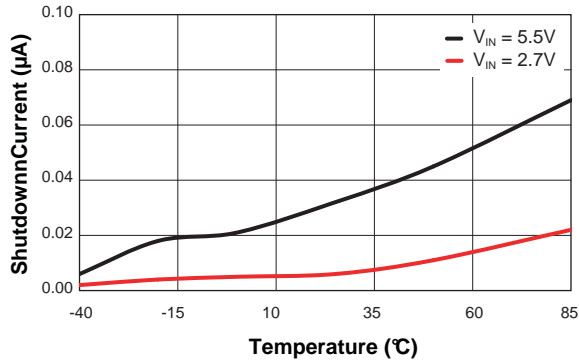

**Quiescent Current vs. Input Voltage (1x Mode)**

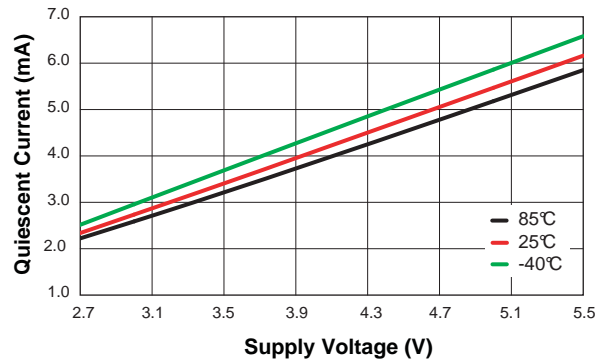

**No Load Operating Current vs. Input Voltage (2x Mode)**

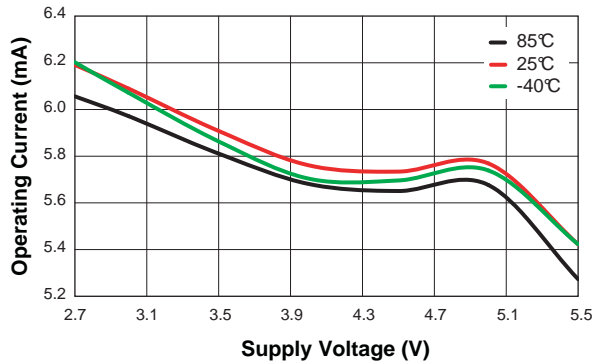

**Frequency vs. Temperature**

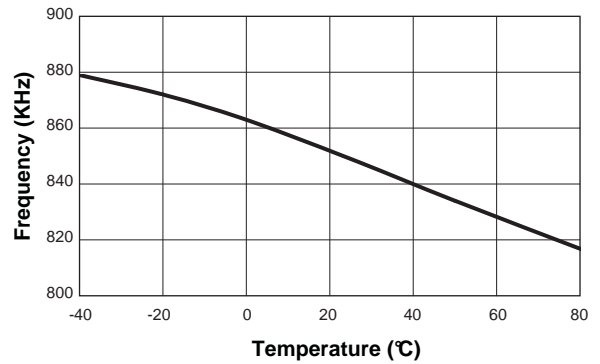

**Current Matching vs. Temperature**

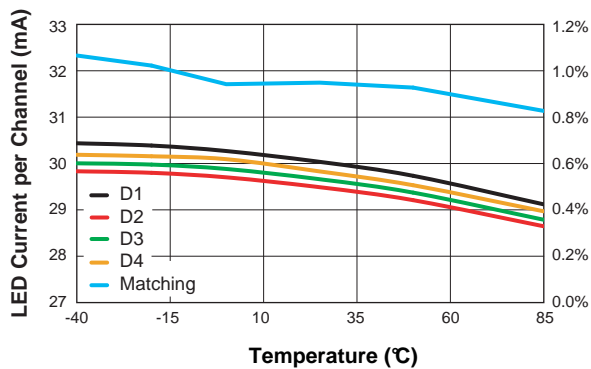

**LED Current Control vs. PWM Duty Ratio (F<sub>PWM</sub> = 25KHz)**

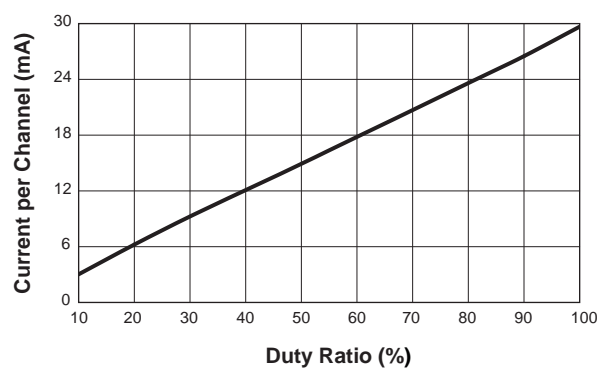

## Typical Characteristics

$V_{IN} = 3.6V$ ,  $C_{IN} = C_{OUT} = C_P = 1\mu F$ ,  $T_A = 25^\circ C$ , unless otherwise noted.

Efficiency vs. Input Voltage

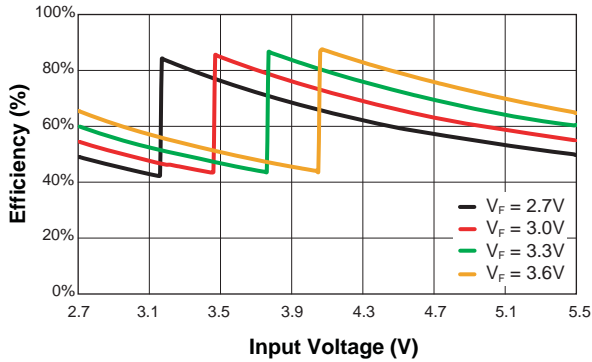

EN/SET Input OFF Timeout vs. Input Voltage

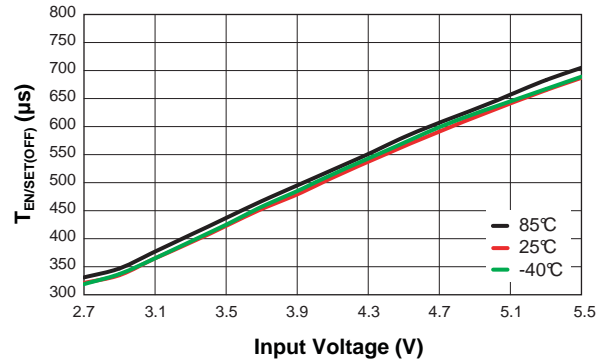

EN Input High Threshold Voltage vs. Input Voltage

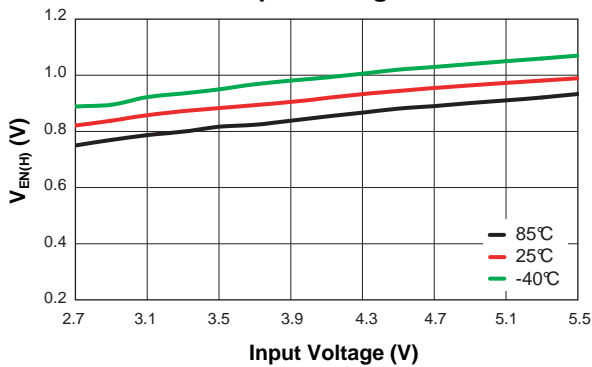

EN Input Low Threshold Voltage vs. Input Voltage

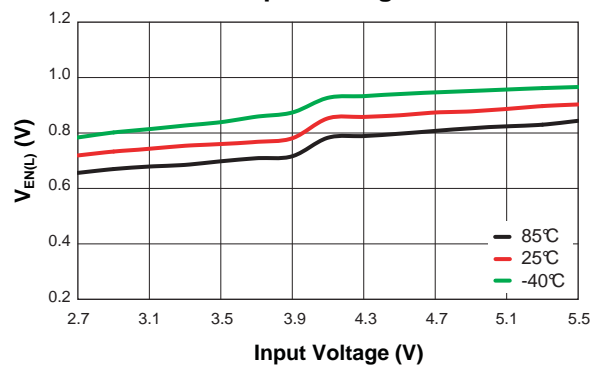

Turn On to 1X Mode  
( $V_{IN} = 4.2V$ ; 30mA/ch)

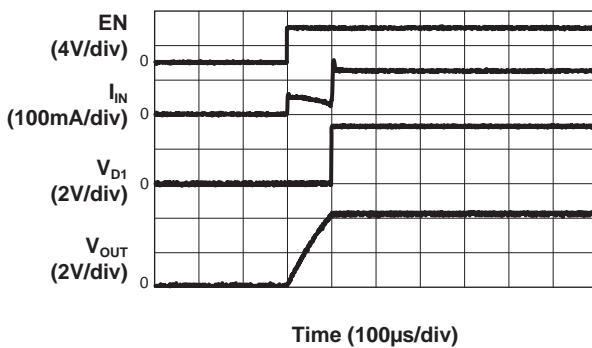

Turn On to 2X Mode  
( $V_{IN} = 3.2V$ ; 30mA/ch)

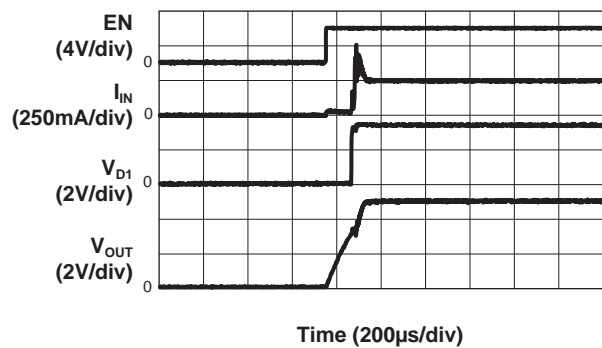

**Typical Characteristics**

$V_{IN} = 3.6V$ ,  $C_{IN} = C_{OUT} = C_P = 1\mu F$ ,  $T_A = 25^\circ C$ , unless otherwise noted.

**Output Ripple Waveform**  
( $V_{IN} = 3.2V$ ; 2X Mode; 30mA/ch)

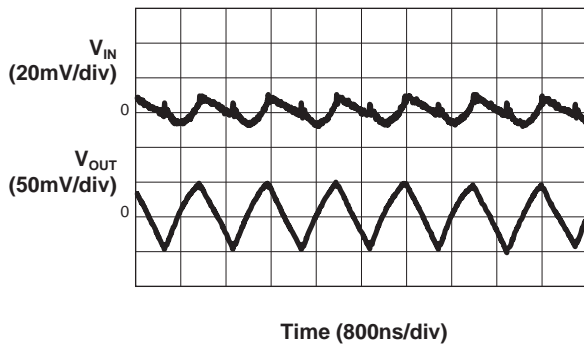

**Turn Off from 1X Mode**  
(30mA/ch)

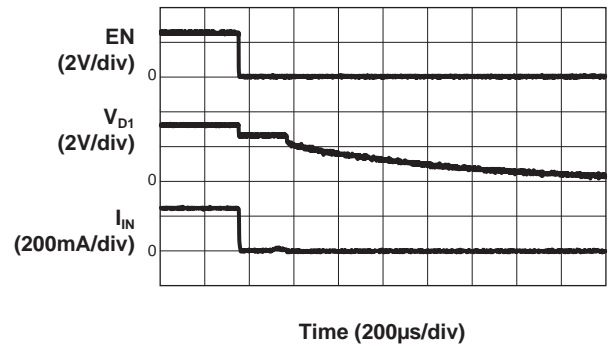



unchanged. By feeding the EN/PWM pin with a proper PWM signal, the RMS current of current source outputs is proportional to the duty ratio of the PWM signal with very little error, which is introduced timing delay. If EN/PWM is kept low for longer than 1ms, the device will enter shutdown mode. In shutdown mode, the device draws less than 1µA current and all current source outputs are inactive.

The relationship between PWM duty ratio and LED current per channel is shown in Table 1. The PWM signal should meet the timing requirements shown in the Electrical Characteristics section of this datasheet in order to guarantee proper operation and accuracy. For example, if the minimum PWM duty ratio is designed as 10%, then the PWM frequency should be higher than 6KHz, to meet the minimum limit of the EN/PWM input off time, which is 150µs.

EN/ PWM Duty Cycle ( $F_{PWM} = 25\text{KHz}$ )	D1-D4 Current (mA)
100%	29.9
90%	26.7
80%	23.8
70%	20.8
60%	17.9
50%	15
40%	12
30%	9.1
20%	6.2
10%	3.2

**Table 1: PWM Duty Cycle vs. LED Current.**

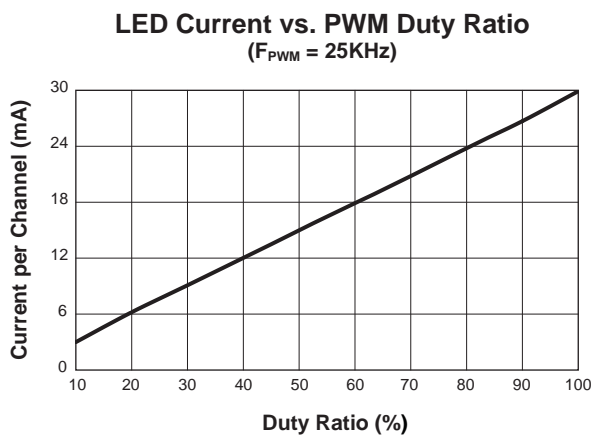

**Figure 1: PWM Duty Cycle vs. LED Current.**

## Application Information

### LED Selection

The AAT3105 is specifically designed for driving white LEDs. However, the device design will allow the AAT3105 to drive most types of LEDs with forward voltage specifications ranging from 2.2V to 4.7V. LED applications may include mixed arrangements for display backlighting, keypad display, and any other application that demands a constant current source generated from a varying input voltage. Since the D1 to D4 constant current sources are matched with negligible supply voltage dependence, the constant current channels will be matched regardless of their respective LED forward voltage ( $V_f$ ) levels.

The low dropout current sources in the AAT3105 maximize performance and make it capable of driving LEDs with high forward voltages. Multiple channels can be combined to obtain a higher LED drive current without complication.

Any unused channel should be connected to GND; the device will detect and shut down the channel. Do not connect any unused channel to the OUT pin.

### Device Switching Noise Performance

The AAT3105 operates at a fixed frequency of approximately 0.85MHz to control noise and limit harmonics that can interfere with the RF operation of mobile communication devices. Back-injected noise appearing on the input pin of the charge pump is 20mV peak-to-peak, typically ten times less than inductor-based DC/DC boost converter white LED backlight solutions. The AAT3105 soft-start feature prevents noise transient effects associated with inrush currents during start-up of the charge pump circuit.

### Shutdown

Since the current switches are the only power returns for all loads, there is no leakage current when all source switches are disabled. To enter shutdown operation, the EN/PWM input for the AAT3105 should be strobed low. After  $t_{OFF}$  (500µs), the AAT3105 will be shut down and typically draws less than 1µA from the input. Registers are reset to 0 in shutdown.

### Power Efficiency and Device Evaluation

The charge pump efficiency discussion in the following sections accounts only for efficiency of the charge pump section itself. Due to the unique circuit architecture and design of the AAT3105, it is very difficult to measure efficiency in terms of a percent value comparing input power over output power.

Since the AAT3105 outputs are pure constant current sources and typically drive individual loads, it is difficult to measure the output voltage for a given output to derive an overall output power measurement. For any given application, white LED forward voltage levels can differ, yet the output drive current will be maintained as a constant.

This makes quantifying output power a difficult task when taken in the context of comparing to other white LED driver circuit topologies. A better way to quantify total device efficiency is to observe the total input power to the device for a given LED current drive level. The best white LED driver for a given application should be based on trade-offs of size, external component count, reliability, operating range, and total energy usage, not just output power over input power efficiency.

The AAT3105 efficiency may be quantified under very specific conditions and is dependent upon the input voltage versus the output voltage across the loads applied to outputs D1 through D4 for a given constant current setting. Depending on the combination of  $V_{IN}$  and voltages sensed at the current sources, the device will operate in load switch mode. When any one of the voltages sensed at the current sources nears dropout, the device will operate in 2x charge pump mode.

Each of these modes will yield different efficiency values. Refer to the following two sections for explanations for each operational mode.

### 1x Mode Efficiency

The AAT3105 1x mode is operational at all times and functions alone to enhance device power conversion efficiency when  $V_{IN}$  is higher than the voltage across the load. When in 1x mode, voltage conversion efficiency is defined as output power divided by input power.

$$\eta = \frac{P_{OUT}}{P_{IN}} = \frac{V_F \cdot I_{LED}}{V_{IN} \cdot I_{IN}} = \frac{V_F \cdot I_{LED}}{V_{IN} \cdot I_{OUT}} \approx \frac{V_F}{V_{IN}}$$

An expression for the ideal efficiency ( $\eta$ ) in 1x charge-pump mode can be expressed as:

$$\eta (\%) = \frac{V_F}{V_{IN}} \cdot 100$$

For a charge pump led driver with  $V_F$  of 3.2V and 4.2V input voltage, the theoretical efficiency is 76%. Due to internal switching losses and IC quiescent current consumption, the actual efficiency can be measured at 73%.

### 2x Charge Pump Mode Efficiency

The AAT3105 contains a charge pump which will boost the input supply voltage in the event where  $V_{IN}$  is less than the voltage required to supply the output. The efficiency ( $\eta$ ) can be simply defined as a linear voltage regulator with an effective output voltage that is equal to one and two times the input voltage. Efficiency ( $\eta$ ) for an ideal 2x charge pump can typically be expressed as the output power divided by the input power.

$$\eta = \frac{P_F}{P_{IN}}$$

In addition, with an ideal 2x charge pump, the output current may be expressed as 1/3 of the input current. The expression to define the ideal efficiency ( $\eta$ ) can be rewritten as

$$\eta = \frac{P_{OUT}}{P_{IN}} = \frac{V_F \cdot I_{LED}}{V_{IN} \cdot I_{IN}} = \frac{V_F \cdot I_{LED}}{V_{IN} \cdot 2 \cdot I_{OUT}} \approx \frac{V_F}{2 \cdot V_{IN}}$$

-or-

$$\eta (\%) = \frac{V_F}{2 \cdot V_{IN}} \cdot 100$$

For a charge pump current source driver with  $V_F$  of 3.2V and 2.7V input voltage, the theoretical efficiency is 59%. Due to internal switching losses and IC quiescent current consumption, the actual efficiency can be measured at 57%. Efficiency will decrease substantially as load current drops below 1mA or when the voltage level at  $V_{IN}$  approaches the voltage level at  $V_{OUT}$ .

### Additional Applications

The current sources of the AAT3105 can be combined freely to drive higher current levels through one LED. As an example, a single LED can be driven at 120mA by combining together D1 through D4 outputs.

For lower-cost applications, the flying capacitor can be removed; C+ and C- should be floating. This will force the AAT3105 to operate in 1x mode. To maintain regulated LED current, the input supply voltage has to be higher than the charge pump's dropout voltage in 1x mode plus the forward voltage of the LED at the preset LED current.

### PCB Layout Considerations

When designing a PCB for the AAT3105, the key requirements are:

1. Place the flying capacitor C1 as close to the chip as possible; otherwise 2x mode performance will be compromised.
2. Place the input and output decoupling capacitors C2 and C3 as close to the chip as possible to reduce switching noise and output ripple.

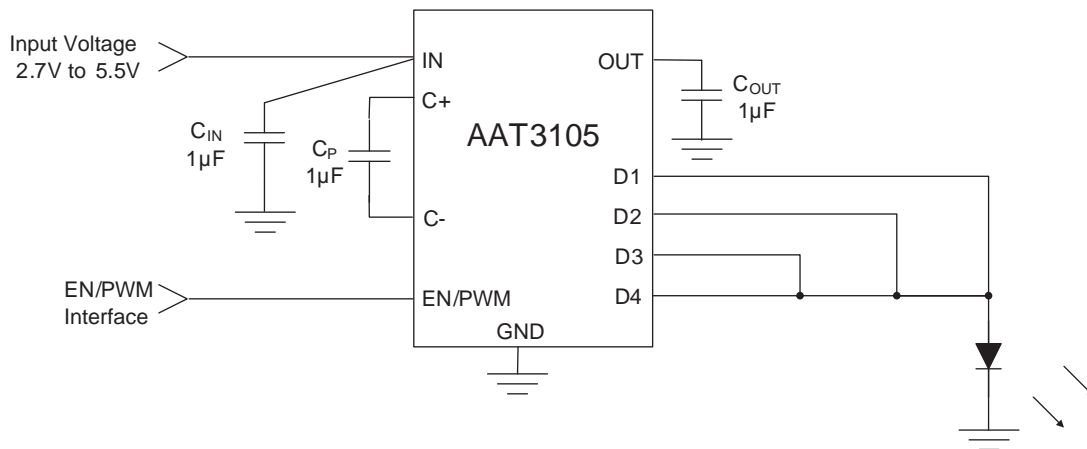

**Figure 1: Higher Current, Single LED Application.**

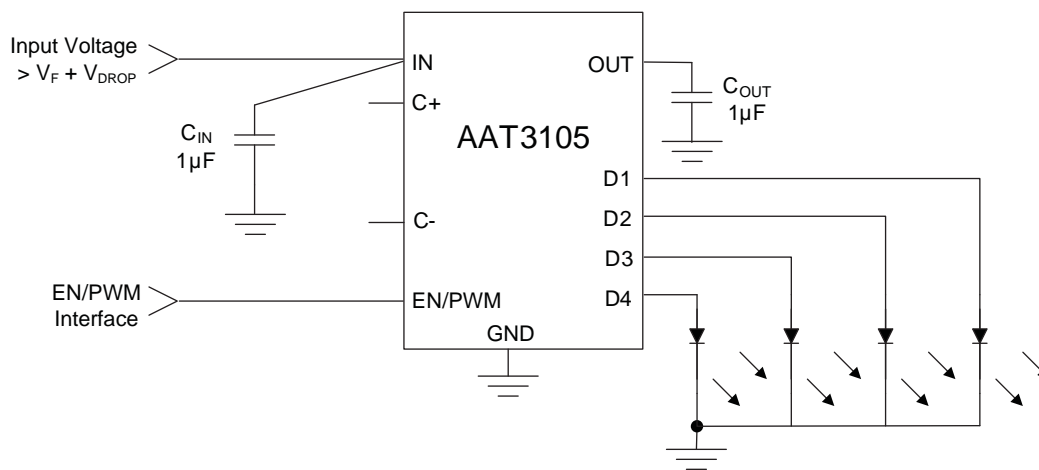

**Figure 2: Lower Cost 1x Mode Application.**

**Evaluation Board PCB Layout**

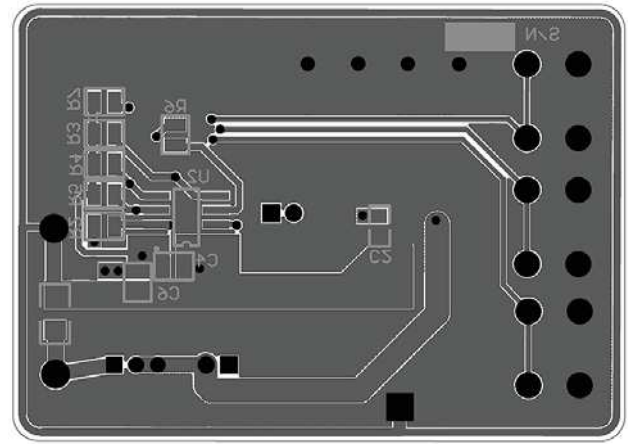
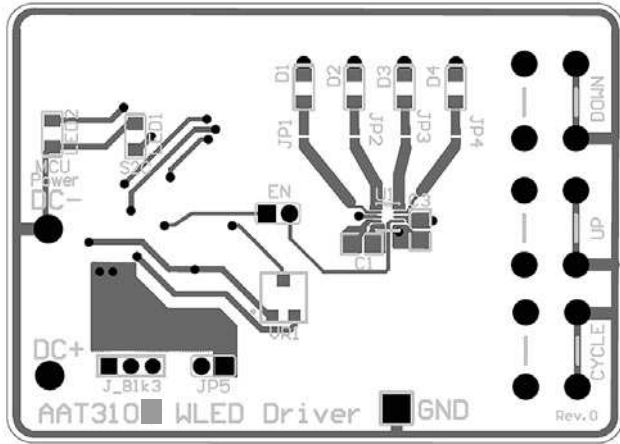

Figure 3: AAT3105 Evaluation Board Top Layer.

Figure 4: AAT3105 Evaluation Board Bottom Layer.

**Evaluation Board Schematic**

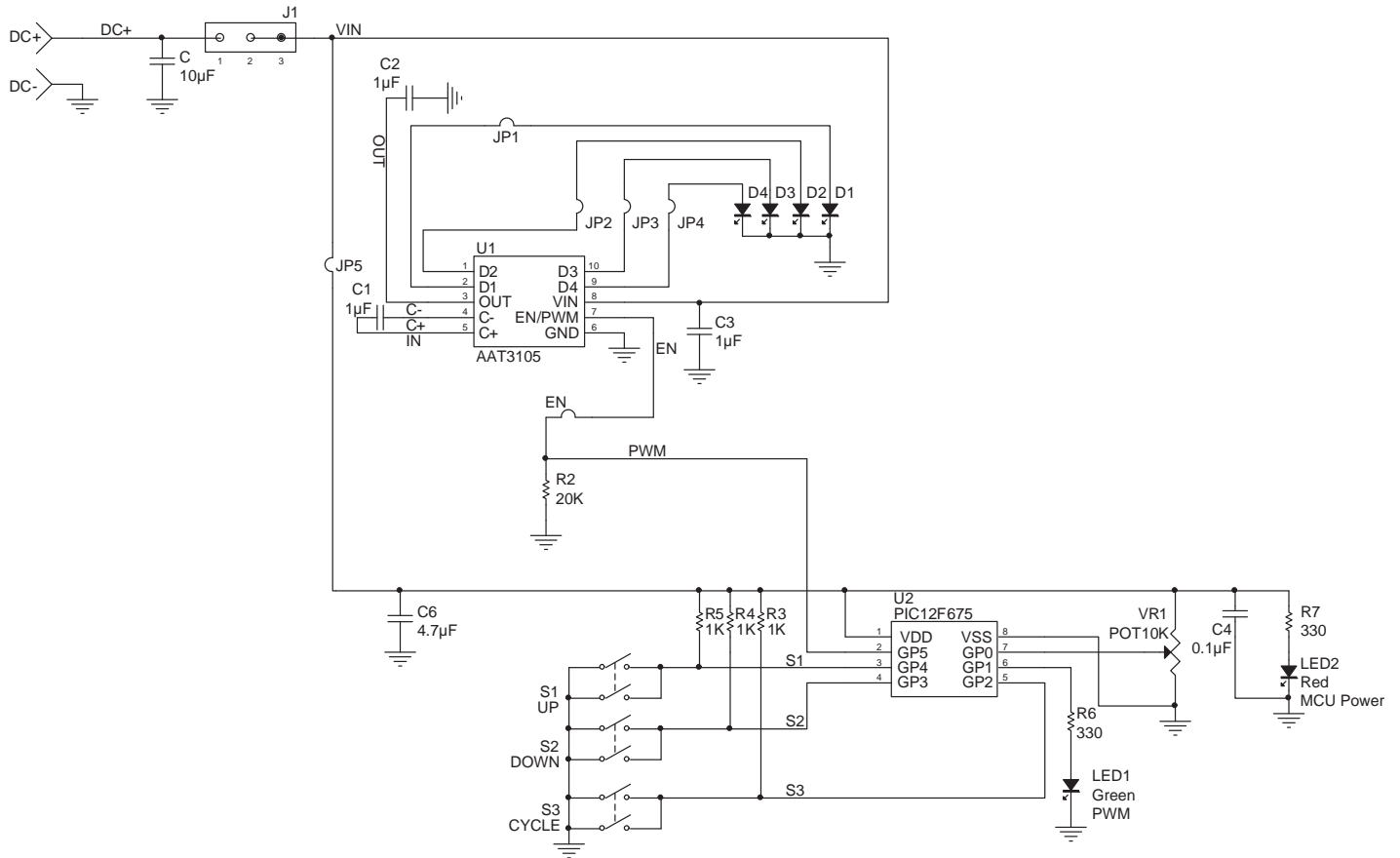

Figure 5: AAT3105 Evaluation Board Schematic.

**Evaluation Board Bill of Materials (BOM)**

Component	Part Number	Description	Manufacturer
U1	AAT31051JQ-T1	High Efficiency 1x/2x Charge Pump for White LED; SC70JW-10 Package	AnalogicTech
U2	PIC12F675	8-Bit CMOS, FLASH-Based $\mu$ C; 8-Pin MCU	Microchip
C1, C2, C3	GRM188R61A105KA61	Cap Ceramic 1 $\mu$ F10V X5R 10% 0603	Murata
C4	GRM219R71C104KA01	Cap Ceramic 0.1 $\mu$ F10V X7R 10% 0805	Murata
C6	GRM219R61A475KE19	Cap Ceramic 4.7 $\mu$ F10V X5R 10% 0805	Murata
C	N/A	Not Soldered	N/A
D1-D4	LW M673	Mini TOPLED White LED; SMD	Osram
LED1	21UGC/TR8 Green LED; 0805	LED0 CMD15	Chicago Miniature Lamp
LED2	21SRC/TR8 Red LED; 0805	LED7 CMD15	Chicago Miniature Lamp
R2	Chip Resistor	20K, 1/16W 1% 0603 SMD	Vishay
R3-R5	Chip Resistor	1K, 1/16W 1% 0603 SMD	Vishay
R6-R7	Chip Resistor	330R, 1/16W 1% 0603 SMD	Vishay
R8	Chip Resistor	1M, 1/16W 1% 0603 SMD	Vishay
R9-R12	Chip Resistor	0R, 1/16W 1% 0603 SMD	Vishay
S1	PTS645TL50	Switch Tact, SPST, 5mm	ITT Industries
S2	PTS645TL50	Switch Tact, SPST, 5mm	ITT Industries
S3	PTS645TL50	Switch Tact, SPST, 5mm	ITT Industries
VR1	EVN-5ESX50B14	10K POT; 3mm Squared SMD	Panasonic-ECG

## Ordering Information

Package	Interface	Current Control, Inverting	Marking <sup>1</sup>	Part Number (Tape and Reel) <sup>2</sup>
SC70JW-10	PWM	Linear	5WXY	<b>AAT3105I JQ-T1</b>



All AnalogicTech products are offered in Pb-free packaging. The term “Pb-free” means semiconductor products that are in compliance with current RoHS standards, including the requirement that lead not exceed 0.1% by weight in homogeneous materials. For more information, please visit our website at <http://www.analogictech.com/about/quality.aspx>.

## Packaging Information

### SC70JW-10

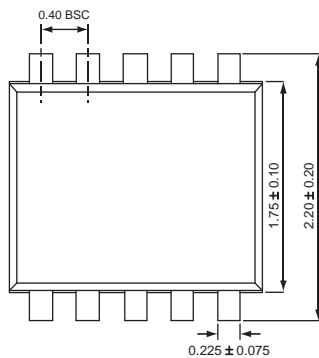

Top View

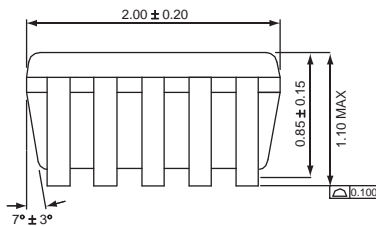

Side View

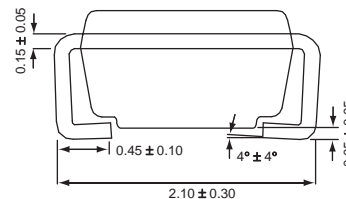

End View

All dimensions in millimeters.

1. XYY = assembly and date code.

2. Sample stock is generally held on part numbers listed in **BOLD**.

**ChargePump™****Low Cost 1x/2x 4 Channel Charge Pump WLED Driver**

**Advanced Analogic Technologies, Inc.**  
3230 Scott Boulevard, Santa Clara, CA 95054  
Phone (408) 737-4600  
Fax (408) 737-4611



© Advanced Analogic Technologies, Inc.  
AnalogicTech cannot assume responsibility for use of any circuitry other than circuitry entirely embodied in an AnalogicTech product. No circuit patent licenses, copyrights, mask work rights, or other intellectual property rights are implied. AnalogicTech reserves the right to make changes to their products or specifications or to discontinue any product or service without notice. Except as provided in AnalogicTech's terms and conditions of sale, AnalogicTech assumes no liability whatsoever, and AnalogicTech disclaims any express or implied warranty relating to the sale and/or use of AnalogicTech products including liability or warranties relating to fitness for a particular purpose, merchantability, or infringement of any patent, copyright or other intellectual property right. In order to minimize risks associated with the customer's applications, adequate design and operating safeguards must be provided by the customer to minimize inherent or procedural hazards. Testing and other quality control techniques are utilized to the extent AnalogicTech deems necessary to support this warranty. Specific testing of all parameters of each device is not necessarily performed. AnalogicTech and the AnalogicTech logo are trademarks of Advanced Analogic Technologies Incorporated. All other brand and product names appearing in this document are registered trademarks or trademarks of their respective holders.