

TOSHIBA CMOS Digital Integrated Circuit Silicon Monolithic

TC74HCT4053AF, TC74HCT4053AFT

Triple 2-Channel Analog Multiplexer/Demultiplexer

The TC74HCT4053A are high speed CMOS ANALOG MULTIPLEXER/DEMUTIPLEXER fabricated with silicon gate C²MOS technology. They achieve the high speed operation similar to equivalent LSTTL while maintaining the CMOS low power dissipation.

This device may be used as a level converter for interfacing TTL or NMOS to High Speed CMOS. This inputs are compatible with TTL, NMOS and CMOS output voltage levels.

The TC74HCT4053A has a 2 channel × 3 configuration.

The digital signal to the control terminal turns “ON” the corresponding switch of each channel a large amplitude signal ($V_{CC} - V_{EE}$) can then be switched by the small logical amplitude ($V_{CC} - GND$) control signal.

For example, in the case of $V_{CC} = 5\text{ V}$, $GND = 0\text{ V}$, $V_{EE} = -5\text{ V}$, signals between -5 V and $+5\text{ V}$ can be switched from the logical circuit with a single power supply of 5 V. As the ON-resistance of each switch is low, they can be connected to circuits with low input impedance.

All inputs are equipped with protection circuits against static discharge or transient excess voltage.

Features

- High speed: $t_{pd} = 30\text{ ns}$ (typ.) at $V_{CC} = 5\text{ V}$
 $V_{EE} = 0\text{ V}$
- Low power dissipation: $I_{CC} = 4\text{ }\mu\text{A}$ (max) at $T_a = 25^\circ\text{C}$
- Compatible with TTL output: $V_{IH} = 2.0\text{ V}$ (min)
 $V_{IL} = 0.8\text{ V}$ (max)
- Wide interfacing ability: LSTTL, NMOS, CMOS
- Low ON resistance: $R_{ON} = 50\text{ }\Omega$ (typ.) at $V_{CC} - V_{EE} = 9\text{ V}$
- High noise immunity: $THD = 0.02\%$ (typ.) at $V_{CC} - V_{EE} = 9\text{ V}$
- Pin and function compatible with 4053B

Pin Assignment

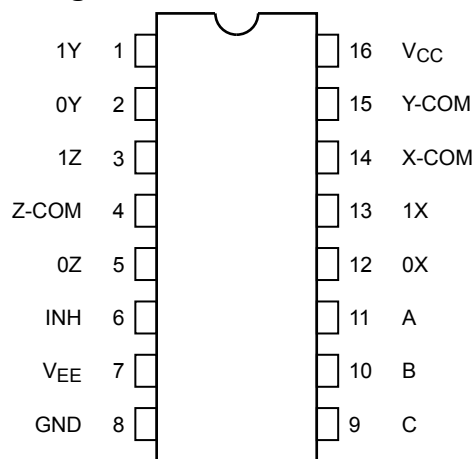

(top view)

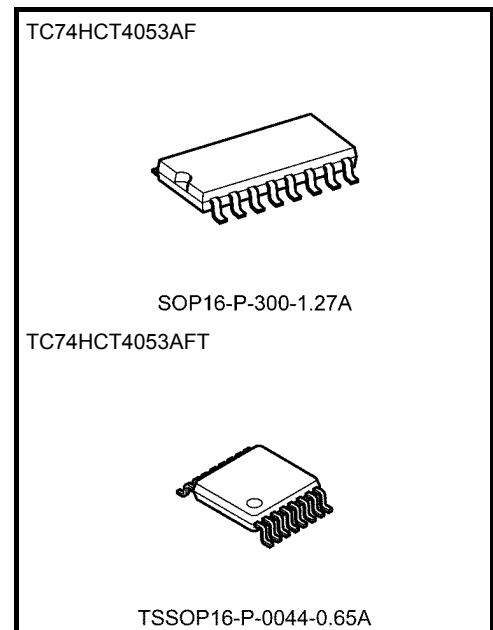

Weight

SOP16-P-300-1.27A : 0.18 g (typ.)
TSSOP16-P-0044-0.65A : 0.06 g (typ.)

Truth Table

Control Inputs				"ON" Channel
Inhibit	C	B	A	HCT4053A
L	L	L	L	0X, 0Y, 0Z
L	L	L	H	1X, 0Y, 0Z
L	L	H	L	0X, 1Y, 0Z
L	L	H	H	1X, 1Y, 0Z
L	H	L	L	0X, 0Y, 1Z
L	H	L	H	1X, 0Y, 1Z
L	H	H	L	0X, 1Y, 1Z
L	H	H	H	1X, 1Y, 1Z
H	X	X	X	NONE

X: Don't care

System Diagram

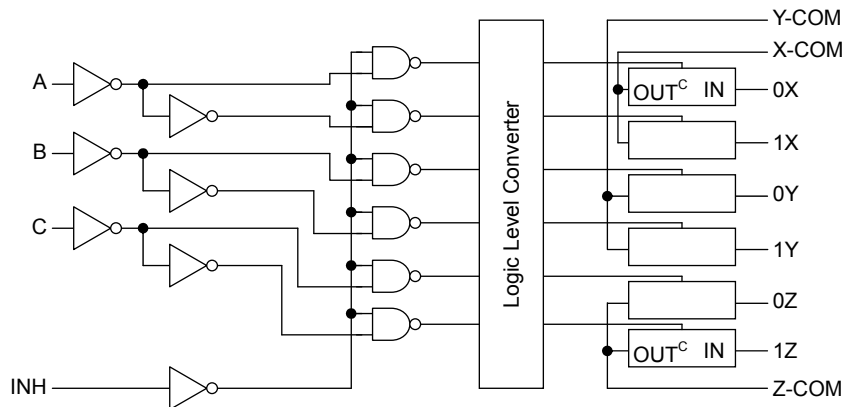

IEC Logic Symbol

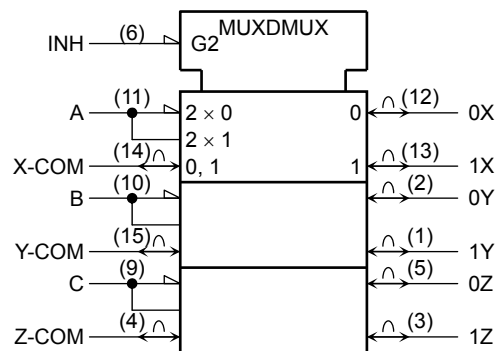

Absolute Maximum Ratings (Note)

Characteristics	Symbol	Rating	Unit
Supply voltage range	V_{CC}	-0.5 to 13	V
Supply voltage range	$V_{CC} - V_{EE}$	-0.5 to 13	V
Control input voltage	V_{IN}	-0.5 to $V_{CC} + 0.5$	V
Switch I/O voltage	$V_{I/O}$	$V_{EE} - 0.5$ to $V_{CC} + 0.5$	V
Control input diode current	I_{ICK}	± 20	mA
I/O diode current	I_{IOK}	± 20	mA
Switch through current	I_T	± 25	mA
DC V_{CC} or ground current	I_{CC}	± 50	mA
Power dissipation	P_D	180	mW
Storage temperature	T_{stg}	-65 to 150	°C

Note: Exceeding any of the absolute maximum ratings, even briefly, lead to deterioration in IC performance or even destruction.

Using continuously under heavy loads (e.g. the application of high temperature/current/voltage and the significant change in temperature, etc.) may cause this product to decrease in the reliability significantly even if the operating conditions (i.e. operating temperature/current/voltage, etc.) are within the absolute maximum ratings and the operating ranges.

Please design the appropriate reliability upon reviewing the Toshiba Semiconductor Reliability Handbook (“Handling Precautions”/“Derating Concept and Methods”) and individual reliability data (i.e. reliability test report and estimated failure rate, etc).

Operating Ranges (Note)

Characteristics	Symbol	Rating	Unit
Supply voltage range	V_{CC}	4.5 to 12	V
Supply voltage range	V_{EE}	-7.5 to 0	V
Supply voltage range	$V_{CC} - V_{EE}$	4.5 to 12	V
Control input voltage	V_{IN}	0 to V_{CC}	V
Switch I/O voltage	$V_{I/O}$	V_{EE} to V_{CC}	V
Operating temperature	T_{opr}	-40 to 85	°C
Control input rise and fall time	t_r, t_f	0 to 500	ns

Note: The operating ranges must be maintained to ensure the normal operation of the device. Unused control inputs must be tied to either V_{CC} or GND.

Electrical Characteristics

DC Characteristics

Characteristics	Symbol	Test Condition		Ta = 25°C			Ta = -40 to 85°C		Unit	
		V _{EE} (V)	V _{CC} (V)	Min	Typ.	Max	Min	Max		
High-level control input voltage	V _{IHC}		4.5 to 5.5 9.0	2.0 2.5	— —	— —	2.0 2.5	— —	V	
Low-level control input voltage	V _{ILC}		4.5 to 5.5 9.0	— —	— —	0.8 0.8	— —	0.8 0.8	V	
ON resistance	R _{ON}	V _{IN} = V _{ILC} or V _{IHC} V _{I/O} = V _{CC} to V _{EE} I _{I/O} ≤ 2 mA	GND	4.5	—	85	180	—	225	Ω
			-4.5	4.5	—	55	120	—	150	
			-5.5	5.5	—	50	110	—	140	
			GND	9.0	—	55	120	—	150	
		V _{IN} = V _{ILC} or V _{IHC} V _{I/O} = V _{CC} or V _{EE} I _{I/O} ≤ 2 mA	GND	4.5	—	70	150	—	190	
			-4.5	4.5	—	50	100	—	125	
			-5.5	5.5	—	45	90	—	115	
			GND	9.0	—	50	100	—	125	
Difference of ON resistance between switches	ΔR _{ON}	V _{IN} = V _{ILC} or V _{IHC} V _{I/O} = V _{CC} to V _{EE} I _{I/O} ≤ 2 mA	GND	4.5	—	10	30	—	35	Ω
			-4.5	4.5	—	5	12	—	15	
			-5.5	5.5	—	5	11	—	14	
Input/output leakage current (switch OFF)	I _{OFF}	V _{OS} = V _{CC} or GND V _{IS} = GND or V _{CC} V _{IN} = V _{ILC} or V _{IHC}	GND	5.5	—	—	±60	—	±600	nA
			-5.5	5.5	—	—	±100	—	±1000	
Switch input leakage current (switch ON)	I _{Iz}	V _{OS} = V _{CC} or GND V _{IN} = V _{ILC} or V _{IHC}	GND	5.5	—	—	±60	—	±600	nA
			-5.5	5.5	—	—	±100	—	±1000	
Control input current	I _{IN}	V _{IN} = V _{CC} or GND	GND	5.5	—	—	±0.1	—	±1.0	μA
Quiescent supply current	I _{CC}	V _{IN} = V _{CC} or GND	GND	5.5	—	—	4.0	—	40.0	μA
			-5.5	5.5	—	—	8.0	—	80.0	
	I _C	Per input: V _{IN} = 0.5 V or 2.4 V Other input: V _{CC} or GND	GND	5.5	—	—	2.0	—	2.9	mA

AC Characteristics ($C_L = 50 \text{ pF}$, Input $t_r = t_f = 6 \text{ ns}$, GND = 0 V)

Characteristics	Symbol	Test Condition		Ta = 25°C			Ta = -40 to 85°C		Unit	
		VEE (V)	VCC (V)	Min	Typ.	Max	Min	Max		
Phase difference between input and output	$\phi_{I/O}$		GND	4.5	—	6	12	—	15	ns
			GND	5.5	—	5	11	—	14	
			GND	9.0	—	4	—	—	—	
Output enable time	t_{pZL} t_{pZH}	(Note 1)	GND	4.5	—	33	50	—	63	ns
			GND	5.5	—	26	45	—	57	
			GND	9.0	—	17	—	—	—	
Output disable time	t_{pLZ} t_{pHZ}	(Note 1)	GND	4.5	—	45	65	—	81	ns
			GND	5.5	—	37	59	—	73	
			GND	9.0	—	26	—	—	—	
Control input capacitance	C_{in}		—	—	—	5	10	—	10	pF
COMMON terminal capacitance	C_{IS}		-5.0	5.0	—	11	20	—	20	pF
SWITCH terminal capacitance	C_{OS}		-5.0	5.0	—	7	15	—	15	pF
Feedthrough capacitance	C_{IOS}		-5.0	5.0	—	0.75	2	—	2	pF
Power dissipation capacitance	C_{PD}	(Note 2)	GND	5.0	—	67	—	—	—	pF

Note 1 $R_L = 1 \text{ k}\Omega$

Note 2: C_{PD} is defined as the value of the internal equivalent capacitance of IC which is calculated from the operating current consumption without load.

Average operating current can be obtained by the equation:

$$I_{CC}(\text{opr}) = C_{PD} \cdot V_{CC} \cdot f_{IN} + I_{CC}$$

Analog Switch Characteristics (GND = 0 V, Ta = 25°C) (Note 1)

Characteristics	Symbol	Test Condition		Typ.	Unit		
		V _{EE} (V)	V _{CC} (V)				
Sine wave distortion (T.H.D)		R _L = 10 kΩ	V _{IN} = 8.0 V _{p-p}	-4.5	4.5	0.020	%
		C _L = 50 pF	V _{IN} = 11.0 V _{p-p}	-5.5	5.5	0.019	
Frequency response (switch ON)	f _{MAX}	Adjust f _{IN} voltage to obtain 0dBm at V _{OS} Increase f _{IN} frequency until dB meter reads -3dB	(Note 2)	-4.5	4.5	190	MHz
			(Note 3)	-4.5	4.5	150	
		R _L = 50 Ω, C _L = 10 pF f _{IN} = 1 MHz, Sine wave	(Note 2)	-5.5	5.5	200	
			(Note 3)	-5.5	5.5	180	
Feed through attenuation (switch OFF)		V _{in} is centered at (V _{CC} - V _{EE})/2 Adjust input for 0dBm		-4.5	4.5	-50	dB
		R _L = 600 Ω, C _L = 50 pF f _{IN} = 1 MHz, Sine wave		-5.5	5.5	-50	
Crosstalk (control input to signal output)		R _L = 600 Ω, C _L = 50 pF f _{IN} = 1 MHz, Square wave (t _r = t _f = 6 ns)		-4.5	4.5	140	mV
				-5.5	5.5	180	
Crosstalk (between any switches)		Adjust V _{IN} to obtain 0dBm at input R _L = 600 Ω, C _L = 50 pF f _{IN} = 1 MHz, Sine wave		-4.5	4.5	-50	dB
				-5.5	5.5	-50	
		R _L = 50 Ω, C _L = 15 pF f _{IN} = 100 kHz, V _{SWITCH} = 1 V _{RMS}		-4.5	4.5	-90	dB

Note 1: These characteristics are determined by design of devices.

Note 2: Input COMMON terminal, and measured at SWITCH terminal.

Note 3: Input SWITCH terminal, and measured at COMMON terminal.

Switching Characteristics Test Circuits

1. t_{pLZ} , t_{pHZ} , t_{pZL} , t_{pZH}

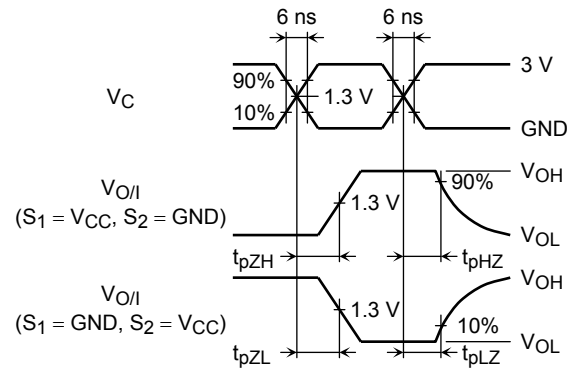
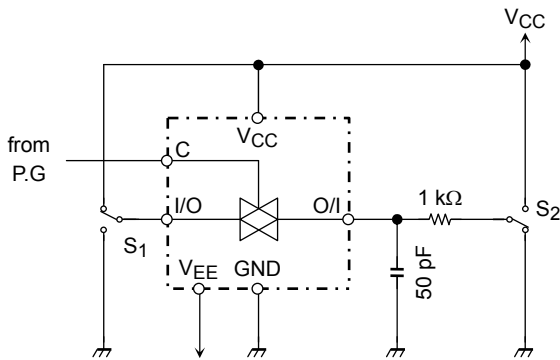

2. Cross Talk (control input – switch output) $f_{IN} = 1 \text{ MHz}$ duty = 50% $t_r = t_f = 6 \text{ ns}$

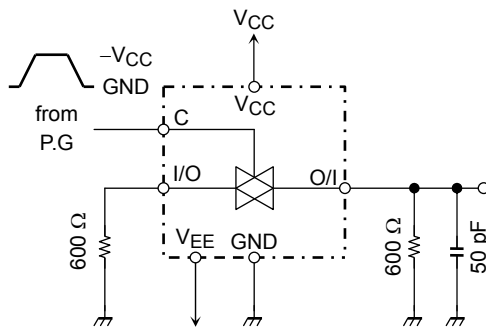

3. Feedthrough Attenuation

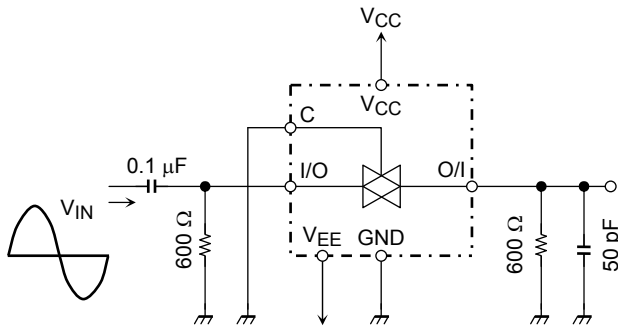

4. C_{IOS} , C_{IS} , C_{OS}

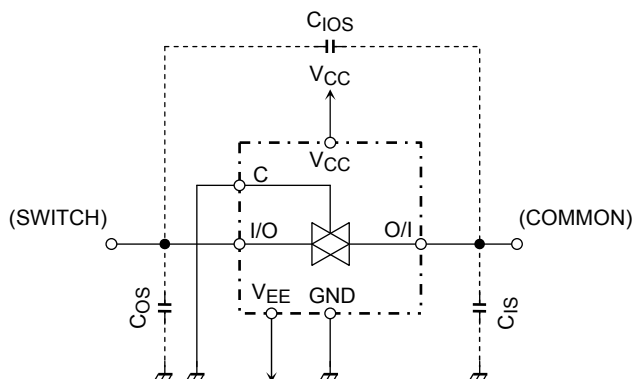

5. Cross Talk (between any two switches)

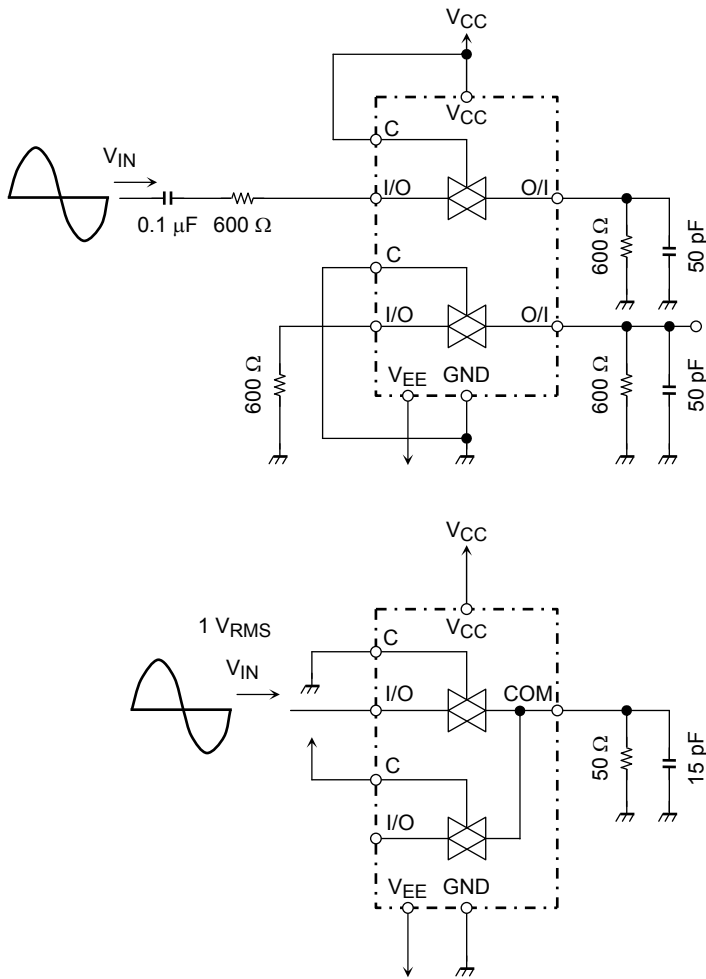

6. Frequency Response (switch ON)

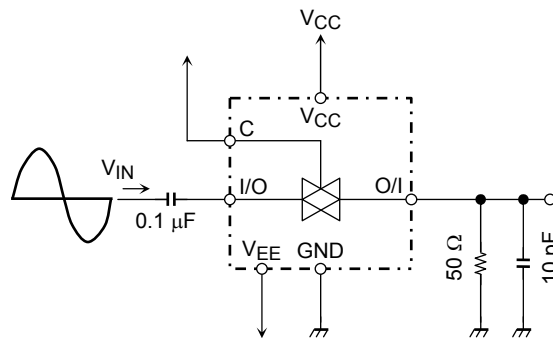

Package Dimensions

SOP16-P-300-1.27A

Unit: mm

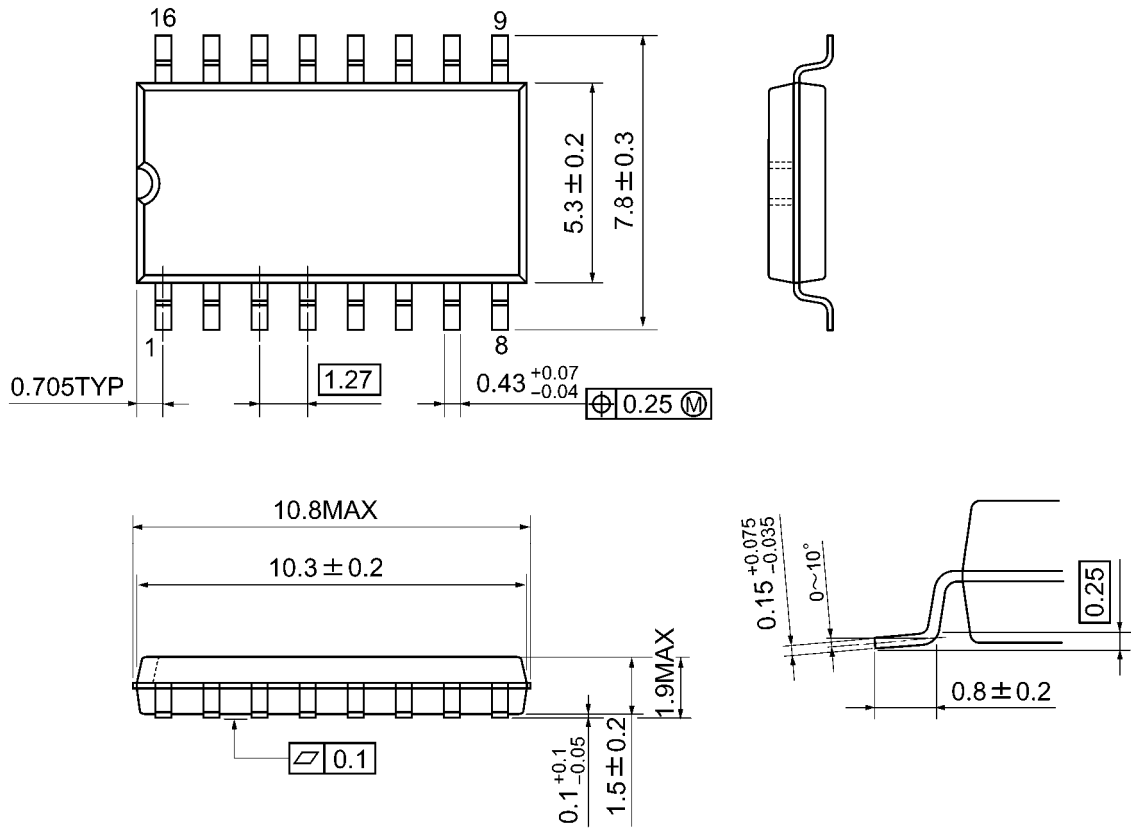

Weight: 0.18 g (typ.)

Package Dimensions

TSSOP16-P-0044-0.65A

Unit: mm

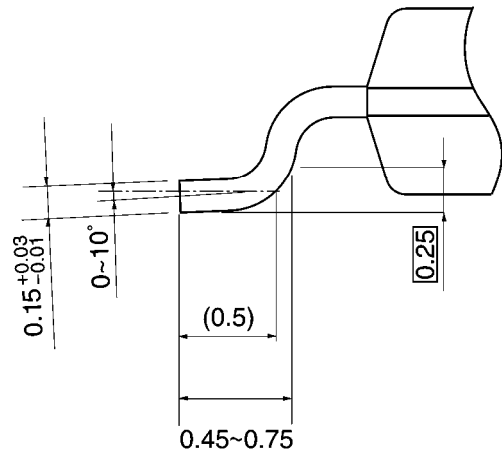
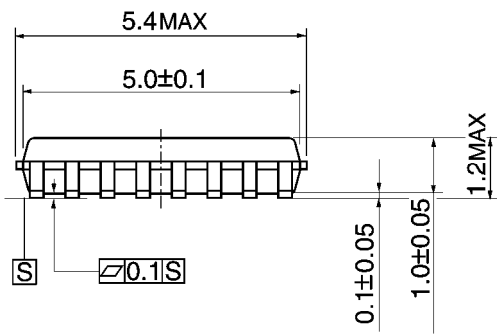
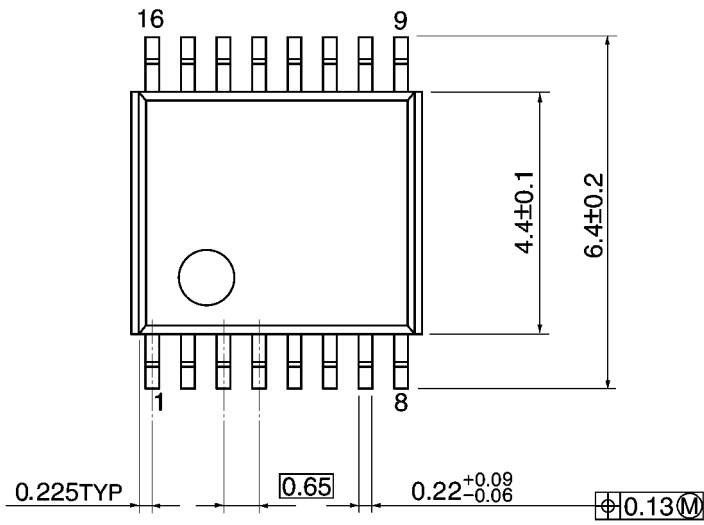

Weight: 0.06 g (typ.)

RESTRICTIONS ON PRODUCT USE

- Toshiba Corporation, and its subsidiaries and affiliates (collectively "TOSHIBA"), reserve the right to make changes to the information in this document, and related hardware, software and systems (collectively "Product") without notice.
- This document and any information herein may not be reproduced without prior written permission from TOSHIBA. Even with TOSHIBA's written permission, reproduction is permissible only if reproduction is without alteration/omission.
- Though TOSHIBA works continually to improve Product's quality and reliability, Product can malfunction or fail. Customers are responsible for complying with safety standards and for providing adequate designs and safeguards for their hardware, software and systems which minimize risk and avoid situations in which a malfunction or failure of Product could cause loss of human life, bodily injury or damage to property, including data loss or corruption. Before customers use the Product, create designs including the Product, or incorporate the Product into their own applications, customers must also refer to and comply with (a) the latest versions of all relevant TOSHIBA information, including without limitation, this document, the specifications, the data sheets and application notes for Product and the precautions and conditions set forth in the "TOSHIBA Semiconductor Reliability Handbook" and (b) the instructions for the application with which the Product will be used with or for. Customers are solely responsible for all aspects of their own product design or applications, including but not limited to (a) determining the appropriateness of the use of this Product in such design or applications; (b) evaluating and determining the applicability of any information contained in this document, or in charts, diagrams, programs, algorithms, sample application circuits, or any other referenced documents; and (c) validating all operating parameters for such designs and applications. **TOSHIBA ASSUMES NO LIABILITY FOR CUSTOMERS' PRODUCT DESIGN OR APPLICATIONS.**
- **PRODUCT IS NEITHER INTENDED NOR WARRANTED FOR USE IN EQUIPMENTS OR SYSTEMS THAT REQUIRE EXTRAORDINARILY HIGH LEVELS OF QUALITY AND/OR RELIABILITY, AND/OR A MALFUNCTION OR FAILURE OF WHICH MAY CAUSE LOSS OF HUMAN LIFE, BODILY INJURY, SERIOUS PROPERTY DAMAGE AND/OR SERIOUS PUBLIC IMPACT ("UNINTENDED USE").** Except for specific applications as expressly stated in this document, Unintended Use includes, without limitation, equipment used in nuclear facilities, equipment used in the aerospace industry, medical equipment, equipment used for automobiles, trains, ships and other transportation, traffic signaling equipment, equipment used to control combustions or explosions, safety devices, elevators and escalators, devices related to electric power, and equipment used in finance-related fields. **IF YOU USE PRODUCT FOR UNINTENDED USE, TOSHIBA ASSUMES NO LIABILITY FOR PRODUCT.** For details, please contact your TOSHIBA sales representative.
- Do not disassemble, analyze, reverse-engineer, alter, modify, translate or copy Product, whether in whole or in part.
- Product shall not be used for or incorporated into any products or systems whose manufacture, use, or sale is prohibited under any applicable laws or regulations.
- The information contained herein is presented only as guidance for Product use. No responsibility is assumed by TOSHIBA for any infringement of patents or any other intellectual property rights of third parties that may result from the use of Product. No license to any intellectual property right is granted by this document, whether express or implied, by estoppel or otherwise.
- **ABSENT A WRITTEN SIGNED AGREEMENT, EXCEPT AS PROVIDED IN THE RELEVANT TERMS AND CONDITIONS OF SALE FOR PRODUCT, AND TO THE MAXIMUM EXTENT ALLOWABLE BY LAW, TOSHIBA (1) ASSUMES NO LIABILITY WHATSOEVER, INCLUDING WITHOUT LIMITATION, INDIRECT, CONSEQUENTIAL, SPECIAL, OR INCIDENTAL DAMAGES OR LOSS, INCLUDING WITHOUT LIMITATION, LOSS OF PROFITS, LOSS OF OPPORTUNITIES, BUSINESS INTERRUPTION AND LOSS OF DATA, AND (2) DISCLAIMS ANY AND ALL EXPRESS OR IMPLIED WARRANTIES AND CONDITIONS RELATED TO SALE, USE OF PRODUCT, OR INFORMATION, INCLUDING WARRANTIES OR CONDITIONS OF MERCHANTABILITY, FITNESS FOR A PARTICULAR PURPOSE, ACCURACY OF INFORMATION, OR NONINFRINGEMENT.**
- Do not use or otherwise make available Product or related software or technology for any military purposes, including without limitation, for the design, development, use, stockpiling or manufacturing of nuclear, chemical, or biological weapons or missile technology products (mass destruction weapons). Product and related software and technology may be controlled under the applicable export laws and regulations including, without limitation, the Japanese Foreign Exchange and Foreign Trade Law and the U.S. Export Administration Regulations. Export and re-export of Product or related software or technology are strictly prohibited except in compliance with all applicable export laws and regulations.
- Please contact your TOSHIBA sales representative for details as to environmental matters such as the RoHS compatibility of Product. Please use Product in compliance with all applicable laws and regulations that regulate the inclusion or use of controlled substances, including without limitation, the EU RoHS Directive. **TOSHIBA ASSUMES NO LIABILITY FOR DAMAGES OR LOSSES OCCURRING AS A RESULT OF NONCOMPLIANCE WITH APPLICABLE LAWS AND REGULATIONS.**