

TD62M4501FG

4CH LOW SATURATION VOLTAGE SINK DRIVER

TD62M4501FG is Multi Chip IC incorporates 4 low saturation discrete (2SC3420) transistors. This IC is suitable for a battery use motor drive and LED display module applications. The suffix (G) appended to the part number represents a Lead (Pb)-Free product.

FEATURES

- Suitable for Motor drive circuit and LED display module
- External Bias resistor
- Low Saturation Voltage
 $V_{CE(sat)} = 0.12\text{ V (Typ.) at } I_C = 1\text{ A}$
 $V_{CE(sat)} = 0.25\text{ V (Typ.) at } I_C = 2\text{ A}$
- SSOP16 (1 mm pitch) small package sealed

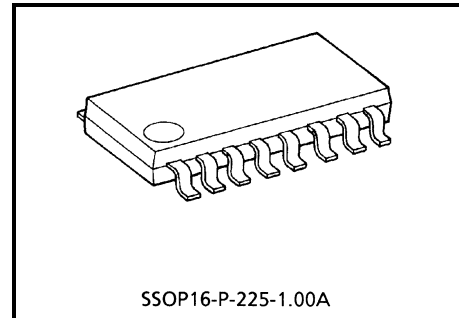

Weight: 0.14 g (typ.)

BLOCK DIAGRAM

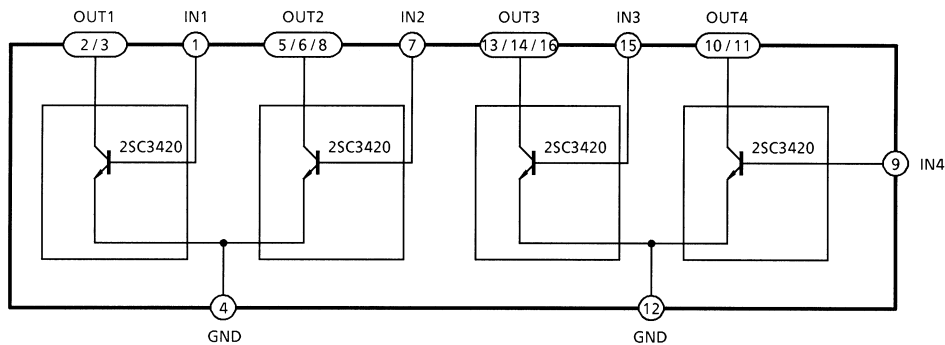

PIN CONNECTION (TOP VIEW)

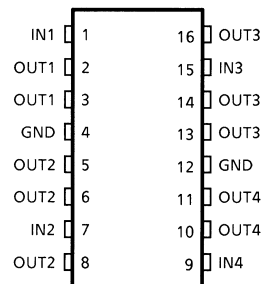

ABSOLUTE MAXIMUM RATINGS (Ta = 25 °C)

CHARACTERISTIC	SYMBOL	RATING	UNIT
Supply Voltage	V _{CC}	20	V
Breakdown Voltage	V _{CB0}	20	V
	V _{CEO}	20	
	V _{EBO}	8	
Output Current	I _{O (AVE)}	2	A
	I _{O (PRAK)}	4 (Note)	
Base Current	I _B	1	A
Power Dissipation	P _D	490	mW
Junction Temperature	T _j	150	°C
Operating Temperature	T _{opr}	-40 ~ 85	°C
Storage Temperature	T _{stg}	-55 ~ 150	°C

Note: T = 10 ms MAX. and maximum duty is less than 30%.

ELECTRICAL CHARACTERISTICS (Ta = 25 °C)

CHARACTERISTIC	SYMBOL	TEST CIR-CUIT	TEST CONDITION	MIN	TYP.	MAX	UNIT
Current Gain	h _{FE (1)}	—	V _{CE} = 2 V, I _C = 0.5 A	140	—	600	—
	h _{FE (2)}	—	V _{CE} = 2 V, I _C = 2.0 A	70	140	—	
Saturation Voltage	V _{CE (sat)}	—	I _C = 1 A, I _B = 25 mA	—	0.12	0.25	V
			I _C = 2 A, I _B = 50 mA	—	0.25	0.50	
Transition Frequency	f _T	—	V _{CE} = 2 V, I _C = 0.5 A	—	100	—	MHz
Leakage Current	I _{OL}	—	V _{CC} = 20 V	—	0	10	μA
Base-Emitter Forward Voltage	V _{BE}	—	V _{CE} = 2 V, I _C = 2.0 A	—	0.84	1.5	V

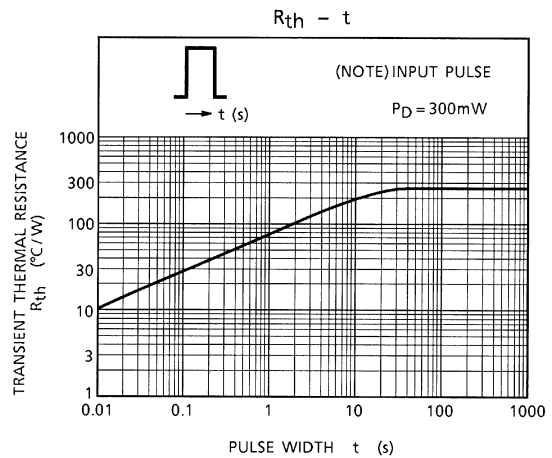
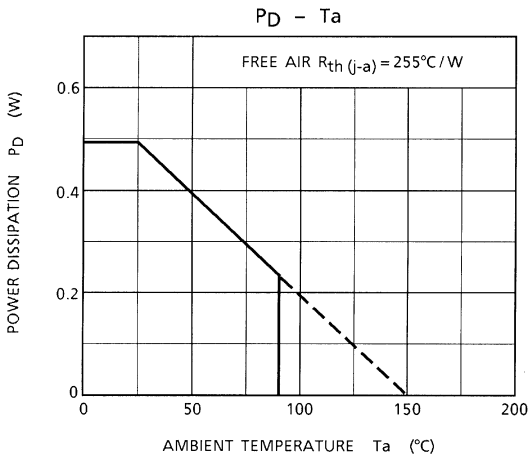
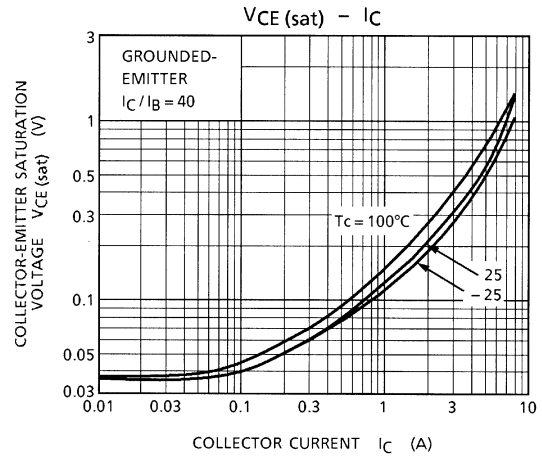
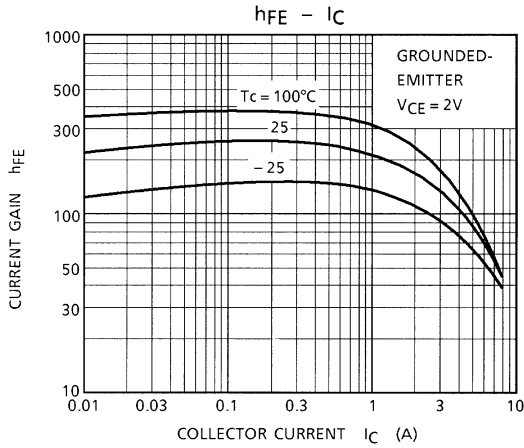

PRECAUTIONS for USING

This IC does not integrate protection circuits such as overcurrent and overvoltage protectors. Thus, if excess current or voltage is applied to the IC, the IC may be damaged. Please design the IC so that excess current or voltage will not be applied to the IC.

Utmost care is necessary in the design of the output line, VCC and GND line since IC may be destroyed due to short-circuit between outputs, air contamination fault, or fault by improper grounding.

PACKAGE DIMENSIONS

SSOP16-P-225-1.00A

Unit: mm

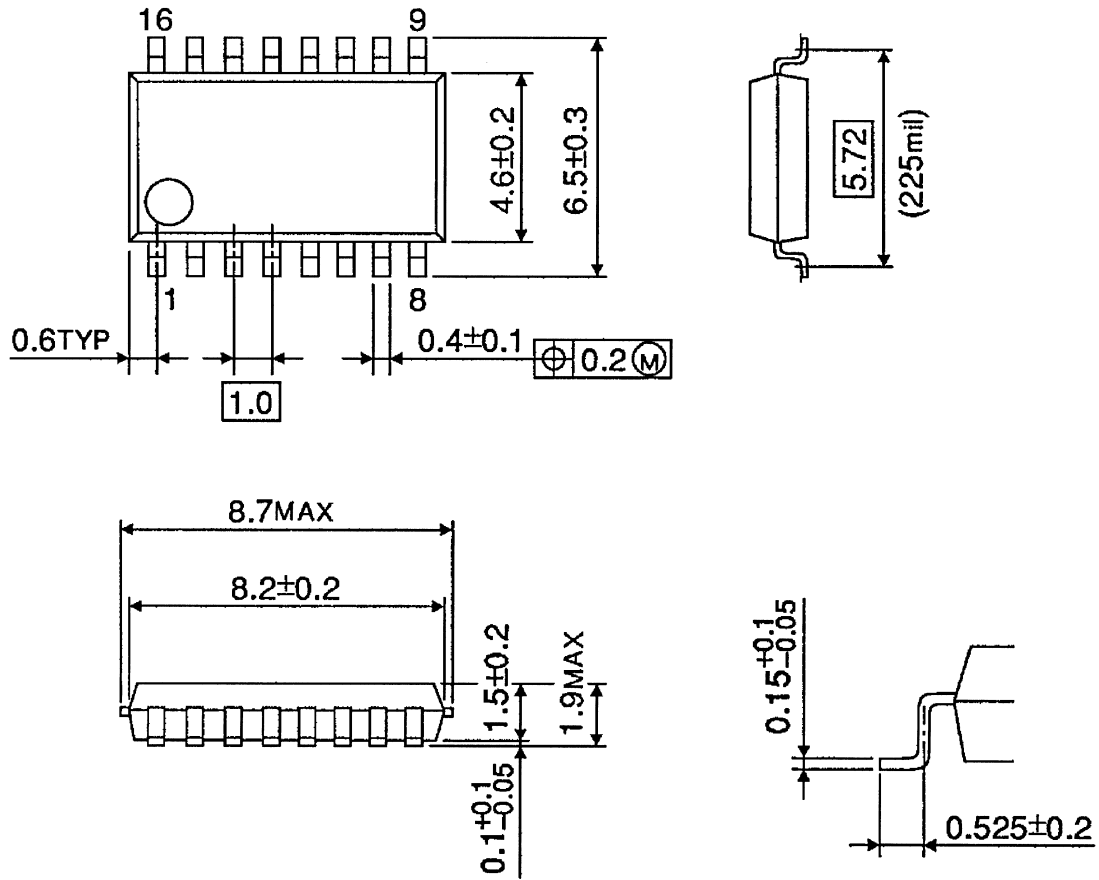

Weight: 0.14 g (Typ.)

Notes on Contents**1. Block Diagrams**

Some functional blocks, circuits, or constants may be omitted or simplified in the block diagram for explanatory purposes.

2. Absolute Maximum Ratings

The absolute maximum rating of a semiconductor device are a set of specified parameter values that must not be exceeded during operation, even for an instant.

If any of these ratings are exceeded during operation, the electrical characteristics of the device may be irreparably altered and the reliability and lifetime of the device can no longer be guaranteed.

Moreover, any exceeding of the ratings during operation may cause breakdown, damage and/or degradation in other equipment. Applications using the device should be designed so that no absolute maximum ratings will ever be exceeded under any operating conditions.

Before using, creating and/or producing designs, refer to and comply with the precautions and conditions set forth in this document.

3. Graphics Characteristics

Graphics characteristics are reference ones and not guaranteed.

Handling of the IC

Ensure that the product is installed correctly to prevent breakdown, damage and/or degradation in the product or equipment.

About solderability, following conditions were confirmed

- Solderability
 - (1) Use of Sn-37Pb solder Bath
 - solder bath temperature = 230°C
 - dipping time = 5 seconds
 - the number of times = once
 - use of R-type flux
 - (2) Use of Sn-3.0Ag-0.5Cu solder Bath
 - solder bath temperature = 245°C
 - dipping time = 5 seconds
 - the number of times = once
 - use of R-type flux

RESTRICTIONS ON PRODUCT USE

060116EBA

- The information contained herein is subject to change without notice. 021023_D
- TOSHIBA is continually working to improve the quality and reliability of its products. Nevertheless, semiconductor devices in general can malfunction or fail due to their inherent electrical sensitivity and vulnerability to physical stress. It is the responsibility of the buyer, when utilizing TOSHIBA products, to comply with the standards of safety in making a safe design for the entire system, and to avoid situations in which a malfunction or failure of such TOSHIBA products could cause loss of human life, bodily injury or damage to property.
In developing your designs, please ensure that TOSHIBA products are used within specified operating ranges as set forth in the most recent TOSHIBA products specifications. Also, please keep in mind the precautions and conditions set forth in the "Handling Guide for Semiconductor Devices," or "TOSHIBA Semiconductor Reliability Handbook" etc. 021023_A
- The TOSHIBA products listed in this document are intended for usage in general electronics applications (computer, personal equipment, office equipment, measuring equipment, industrial robotics, domestic appliances, etc.). These TOSHIBA products are neither intended nor warranted for usage in equipment that requires extraordinarily high quality and/or reliability or a malfunction or failure of which may cause loss of human life or bodily injury ("Unintended Usage"). Unintended Usage include atomic energy control instruments, airplane or spaceship instruments, transportation instruments, traffic signal instruments, combustion control instruments, medical instruments, all types of safety devices, etc. Unintended Usage of TOSHIBA products listed in this document shall be made at the customer's own risk. 021023_B
- The products described in this document shall not be used or embedded to any downstream products of which manufacture, use and/or sale are prohibited under any applicable laws and regulations. 060106_Q
- The information contained herein is presented only as a guide for the applications of our products. No responsibility is assumed by TOSHIBA for any infringements of patents or other rights of the third parties which may result from its use. No license is granted by implication or otherwise under any patent or patent rights of TOSHIBA or others. 021023_C
- The products described in this document are subject to the foreign exchange and foreign trade laws. 021023_E