

FIBER OPTIC RECEIVING MODULE

TORX1950(F)

GENERAL PURPOSE OPTICAL RECEIVING MODULE

- Data rate: DC to 10 Mb / s (NRZ code)
- For JIS F05 Optical Connector
- TTL Interface
- ATC (Automatic Threshold Control) circuit is used for stabilized output at a wide range of optical power level.

1. Absolute Maximum Ratings (Ta = 25°C)

Characteristics	Symbol	Rating	Unit
Storage Temperature	T _{stg}	-40 to 85	°C
Operating Temperature	T _{opr}	-40 to 85	°C
Supply Voltage	V _{CC}	-0.5 to 6	V
Low Level Output Current	I _{OL}	20	mA
High Level Output Current	I _{OH}	-1	mA
Soldering Temperature	T _{sol}	260 (Note 1)	°C

Note 1: Soldering time ≤ 10 s (More than 1 mm apart from the package).

Using continuously heavy loads (e.g. the application of high temperature/current/voltage and the significant change in temperature, etc) may cause this product to decrease in the reliability significantly even if the operating conditions (i.e. operating temperature/ current/ voltage, etc.) are within the absolute maximum ratings. Please design the appropriate reliability upon reviewing the Toshiba Semiconductor Reliability Handbook ("Handling Precautions"/"Derating Concept and Methods") and individual reliability data (i.e. reliability test report and estimated failure rate, etc).

2. Operating Ranges

Characteristics	Symbol	Min	Typ.	Max	Unit
Supply Voltage	V _{CC}	4.75	5.0	5.25	V
High Level Output Current	I _{OH}	-	-	-150	μA
Low Level Output Current	I _{OL}	-	-	2.0	mA

3. Electrical and Optical Characteristics (Ta = 25°C, Vcc=5V)

Characteristics	Symbol	Test Condition	Min	Typ.	Max	Unit		
Data Rate		NRZ Code(Note 2)	DC	-	10	Mb / s		
Transmission Distance		APF (Note3)	DC to 10 Mb/s		0.2	-	50	m
		H-PCF (Note4)	DC to 10 Mb/s		0.2	-	1000	m
		H-PCF (Note5)			0.2	-	700	m
		H-PCF (Note4)	DC to 6 Mb/s		0.2	-	1000	m
		H-PCF (Note5)			0.2	-	800	m
Pulse Width Distortion (Note 6)	Δtw	Using APF or H-PCF and TOTX1950(F),TOTX1960(F) Pulse width 100 ns Pulse cycle 200 ns, CL = 10 pF	-30	-	30	ns		
		Using APF or H-PCF and TOTX1950(F),TOTX1960(F) Pulse width 165 ns Pulse cycle 330 ns, CL = 10 pF	-55	-	55	ns		
Maximum Receivable Power (Note 7)	P_{MAX}	DC to 10 Mb / s, Using APF	-9	-	-	dBm		
		DC to 10 Mb / s, Using H-PCF	-14	-	-	dBm		
Minimum Receivable Power (Note 7)	P_{MIN}	DC to 10 Mb / s, Using APF	-	-	-27	dBm		
		DC to 6 Mb / s, Using APF	-	-	-28	dBm		
		DC to 10 Mb / s, Using H-PCF	-	-	-29	dBm		
		DC to 6 Mb / s, Using H-PCF	-	-	-30	dBm		
Current Consumption	I_{CC}		-	9	20	mA		
High Level Output Voltage	V_{OH}	Vcc=4.75V	3.5	4.0	-	V		
Low Level Output Voltage	V_{OL}	Vcc=5.25V	-	0.1	0.4	V		

Note 2: High level output when optical flux is received. Low level output when it is not received.
The duty factor must be kept 25 to 75%.

Note 3: All Plastic fiber (980 / 1000 μ m) with polished surface.

Note 4: H-PCF (200 / 230 μ m). F05 type optical connector with polished surface.

Note 5: H-PCF (200 / 230 μ m). F05 type optical connector with non-polished surface (cut by fiber cutter).

Note 6: Between input of TOTX1950(F),TOTX1960(F) and output of TORX1950(F).

Note 7: $BER \leq 10^{-9}$, Valued by peak.

4. Application Circuit

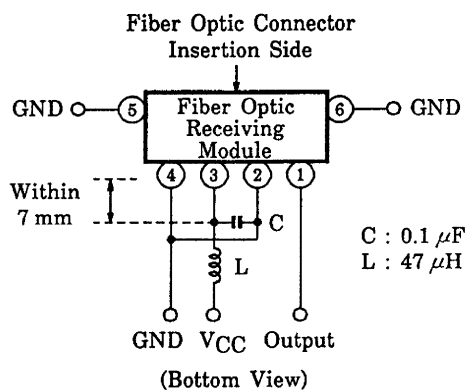

5. Applicable Optical Fiber with Fiber Optic Connectors

All Plastic Fiber (980 μ m core / 1000 μ m cladding), NA=0.5
F05 type optical connector with Polished Surface.

Plastic Cladding Silica Fiber (200 μ m / 230 μ m cladding),
F05 type optical connector with Polished Surface.

6. Precautions during use

(1) Absolute maximum rating

The absolute maximum ratings are the limit values which must not be exceeded during operation of device. None of these rating value must not be exceeded. If The absolute maximum rating value is exceeded, the characteristics of devices may never be recovered properly. In extreme cases, the device may be permanently damages.

(2) Operating Range

The operating range is the range of conditions necessary for the device to operate as specified in individual technical datasheets and databooks. Care must be exercised in the design of the equipment. If a device is used under conditions that do not exceed absolute maximum ratings but exceed the operating range, the specifications related to device operation and electrical characteristics may not be met, resulting in a decrease in reliability.

If greater reliability is required, derate the device's operating ranges for voltage, current, power and temperature before use.

(3) Soldering

Optical modules are comprised of internal semiconductor devices. However, in principle, optical modules are optical components. During soldering, ensure that flux dose not contact with the emitting surface or detecting surface. Also ensure that proper flux removal is conducted after soldering.

Some optical modules come with protective cap. The protective cap is used to avoid malfunction when the optical module is not in use. Not that it is not dust or waterproof.

As mentioned before, optical modules are optical component. Thus, in principle, soldering where there may be flux residue or flux removal after soldering is not recommended. Toshiba recommends that soldering be performed without the optical module mounted on the board. Then, after the board is cleaned, solder the optical module manually. Do not perform any further cleaning.

If the optical module cannot be soldered manually, use non-halogen (chlorine-free) flux and make sure, without cleaning, there is no residue such as chlorine. This is one of the ways to eliminate the effects of flux. In such a case, check the reliability.

(4) Noise resistance

Where the fiber optic receiving module case uses conductive resin, shield by connecting the reinforcing pin at a front end of the module to GND. When using this optical module, connect the pin to SIGNAL-GND.

Where the fiber optic receiving module case has a resistance of several tens of ohms, take care that the case does not contact power line of other circuits.

It is believed that the use of optical transfer devices improve the noise resistance. In principle, optical fiber is not affected by noise. However, especially receiving module which handle signals whose level is extremely small, are comparatively more susceptible to noise.

TOSLINK improves noise resistance using a conductive case. However, the current of the signal output from the photodiode of the optic receiving module is extremely small. Thus, depending on the usage environment, shielding the case is not sufficient for noise resistance.

When using TOSLINK, Toshiba recommends that you test using the actual device and check the noise resistance.

Use a simple noise filter on the TOSLINK fiber optic receiving module power line. If the ripple in power supply used is high, further reinforce the filter.

When locating the optical module in an area susceptible to radiated noise, increase shielding by covering the optical module and the power line filter using a metallic cover.

- (5) **Vibration and shock**
This module is resin-molded construction with wire fixed by resin. This structure is relatively sound against vibration or shock, In actual equipment, there are some cases where vibration, shock, and stress is applied to soldered parts or connected parts, resulting in line cut. Attention must be paid to the design of the mechanism for applications which are subject to large amounts of vibration.

- (6) **Fixing fiber optical receiving module**
Solder the fixed pin (pins 5 and 6) of fiber optic receiving module TORX1950(F) to the printed circuit board to fix the module to the board.

- (7) **Shielding and wiring pattern of fiber optical receiving modules**
To shield, connect the fixed pins (pins 5 and 6) of fiber optic transceiving module TORX1950(F) to the GND.
Where the fiber optical receiving module uses conductive resin, be careful that the case does not touch wiring (including land).
To improve noise resistance, shield the optical module and the power line filter using a metallic cover.

- (8) **Solvent**
When using solvent for flux removal, do not use a high acid or high alkali solvent. Be careful not to pour solvent in the optical connector ports. If solvent is inadvertently poured there, clean with cotton tips.

- (9) **Protective cap**
When the fiber optic receiving module TORX1950(F) is not in use, use the protective cap.

- (10) **Supply voltage**
Use the supply voltage within the operating ranges ($V_{CC} = 5 \pm 0.25$ V). Make sure that supply voltage does not exceed the absolute maximum rating value of 6 V, even instantaneously.

- (11) **Output**
When the receiver output is at low level and connected to the power supply, or when the output is at high level and connected to GND, the internal IC may be destroyed.

- (12) **Soldering condition**
Solder at 260°C or less within ten seconds.

- (13) **Incidence of a photo Flash**
If strong light such as a photo flash is incident on an optical module, a transmission error may occur. Be careful to avoid such situations.

- (14) **Precaution on waste**
When discarding devices and packing materials, follow procedures stipulated by local regulations in order to protect the environment against contamination.

7 Package Outline drawing

Unit: mm

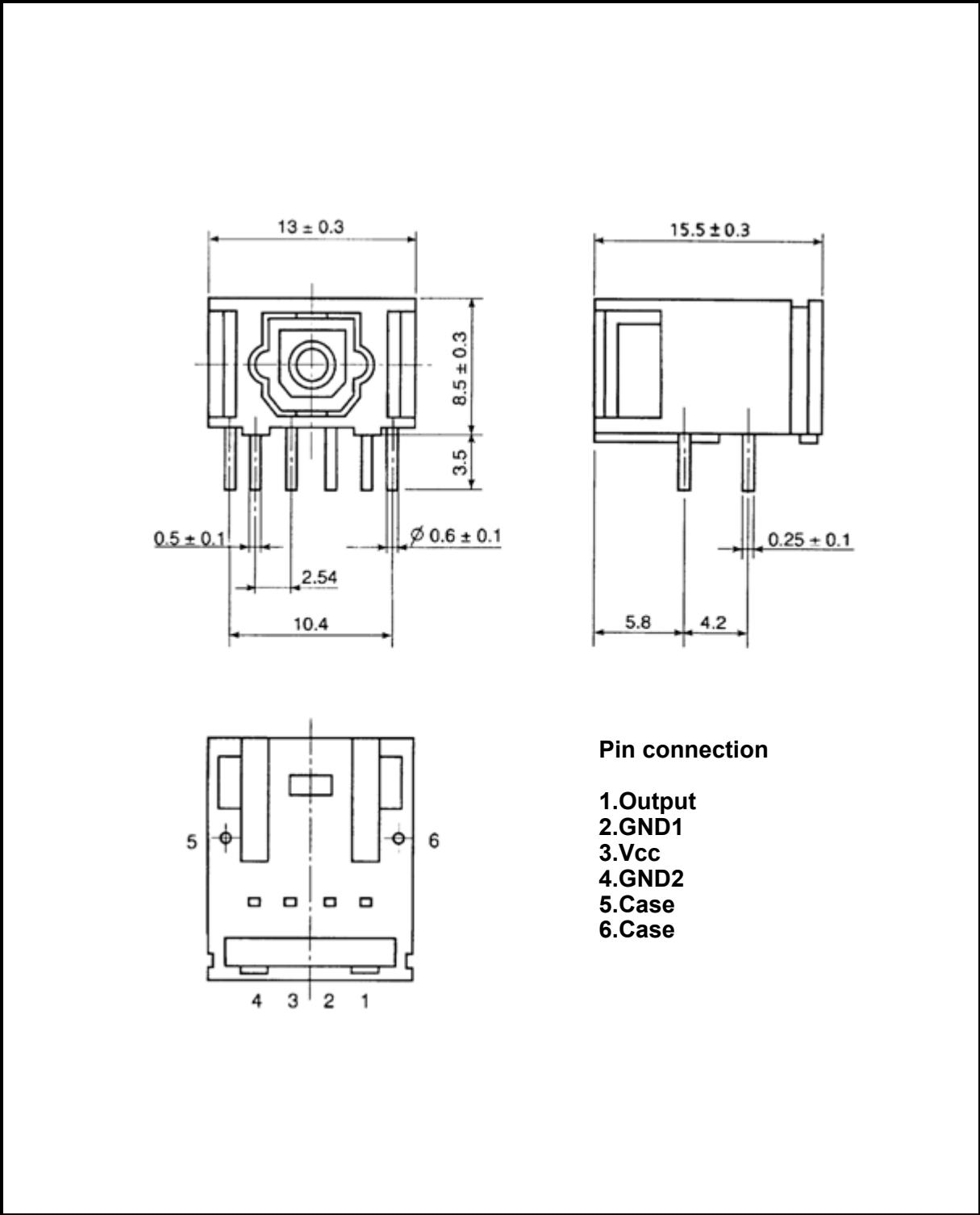

RESTRICTIONS ON PRODUCT USE

- Toshiba Corporation, and its subsidiaries and affiliates (collectively "TOSHIBA"), reserve the right to make changes to the information in this document, and related hardware, software and systems (collectively "Product") without notice.
- This document and any information herein may not be reproduced without prior written permission from TOSHIBA. Even with TOSHIBA's written permission, reproduction is permissible only if reproduction is without alteration/omission.
- Though TOSHIBA works continually to improve Product's quality and reliability, Product can malfunction or fail. Customers are responsible for complying with safety standards and for providing adequate designs and safeguards for their hardware, software and systems which minimize risk and avoid situations in which a malfunction or failure of Product could cause loss of human life, bodily injury or damage to property, including data loss or corruption. Before customers use the Product, create designs including the Product, or incorporate the Product into their own applications, customers must also refer to and comply with (a) the latest versions of all relevant TOSHIBA information, including without limitation, this document, the specifications, the data sheets and application notes for Product and the precautions and conditions set forth in the "TOSHIBA Semiconductor Reliability Handbook" and (b) the instructions for the application with which the Product will be used with or for. Customers are solely responsible for all aspects of their own product design or applications, including but not limited to (a) determining the appropriateness of the use of this Product in such design or applications; (b) evaluating and determining the applicability of any information contained in this document, or in charts, diagrams, programs, algorithms, sample application circuits, or any other referenced documents; and (c) validating all operating parameters for such designs and applications. **TOSHIBA ASSUMES NO LIABILITY FOR CUSTOMERS' PRODUCT DESIGN OR APPLICATIONS.**
- Product is intended for use in general electronics applications (e.g., computers, personal equipment, office equipment, measuring equipment, industrial robots and home electronics appliances) or for specific applications as expressly stated in this document. Product is neither intended nor warranted for use in equipment or systems that require extraordinarily high levels of quality and/or reliability and/or a malfunction or failure of which may cause loss of human life, bodily injury, serious property damage or serious public impact ("Unintended Use"). Unintended Use includes, without limitation, equipment used in nuclear facilities, equipment used in the aerospace industry, medical equipment, equipment used for automobiles, trains, ships and other transportation, traffic signaling equipment, equipment used to control combustions or explosions, safety devices, elevators and escalators, devices related to electric power, and equipment used in finance-related fields. Do not use Product for Unintended Use unless specifically permitted in this document.
- Do not disassemble, analyze, reverse-engineer, alter, modify, translate or copy Product, whether in whole or in part.
- Product shall not be used for or incorporated into any products or systems whose manufacture, use, or sale is prohibited under any applicable laws or regulations.
- The information contained herein is presented only as guidance for Product use. No responsibility is assumed by TOSHIBA for any infringement of patents or any other intellectual property rights of third parties that may result from the use of Product. No license to any intellectual property right is granted by this document, whether express or implied, by estoppel or otherwise.
- **ABSENT A WRITTEN SIGNED AGREEMENT, EXCEPT AS PROVIDED IN THE RELEVANT TERMS AND CONDITIONS OF SALE FOR PRODUCT, AND TO THE MAXIMUM EXTENT ALLOWABLE BY LAW, TOSHIBA (1) ASSUMES NO LIABILITY WHATSOEVER, INCLUDING WITHOUT LIMITATION, INDIRECT, CONSEQUENTIAL, SPECIAL, OR INCIDENTAL DAMAGES OR LOSS, INCLUDING WITHOUT LIMITATION, LOSS OF PROFITS, LOSS OF OPPORTUNITIES, BUSINESS INTERRUPTION AND LOSS OF DATA, AND (2) DISCLAIMS ANY AND ALL EXPRESS OR IMPLIED WARRANTIES AND CONDITIONS RELATED TO SALE, USE OF PRODUCT, OR INFORMATION, INCLUDING WARRANTIES OR CONDITIONS OF MERCHANTABILITY, FITNESS FOR A PARTICULAR PURPOSE, ACCURACY OF INFORMATION, OR NONINFRINGEMENT.**
- Do not use or otherwise make available Product or related software or technology for any military purposes, including without limitation, for the design, development, use, stockpiling or manufacturing of nuclear, chemical, or biological weapons or missile technology products (mass destruction weapons). Product and related software and technology may be controlled under the Japanese Foreign Exchange and Foreign Trade Law and the U.S. Export Administration Regulations. Export and re-export of Product or related software or technology are strictly prohibited except in compliance with all applicable export laws and regulations.
- Please contact your TOSHIBA sales representative for details as to environmental matters such as the RoHS compatibility of Product. Please use Product in compliance with all applicable laws and regulations that regulate the inclusion or use of controlled substances, including without limitation, the EU RoHS Directive. TOSHIBA assumes no liability for damages or losses occurring as a result of noncompliance with applicable laws and regulations.