

TPD7211F

Power MOSFET Gate Driver for half-bridge

TPD7211F is a Power MOSFET gate driver for half-bridge circuit. BiCD process is applied on this product.

Features

- Power MOSFET gate driver for half-bridge
- High-side can operate P channel MOSFET, Low-side can operate N channel MOSFET
- Housed in the PS-8 package and supplied in embossed carrier tape.

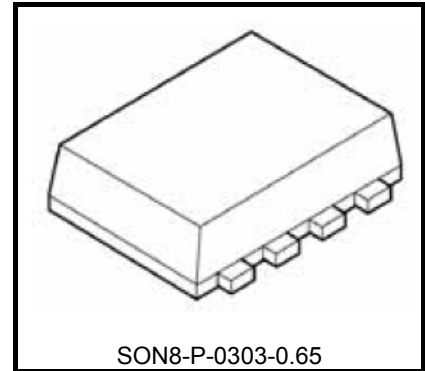

SON8-P-0303-0.65
Weight: 0.017g (typ.)

Pin Assignment (top view)

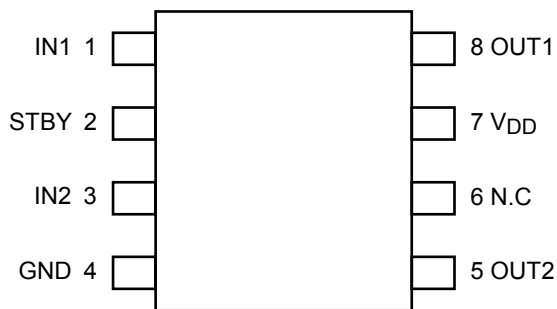

(TOP VIEW)

Marking

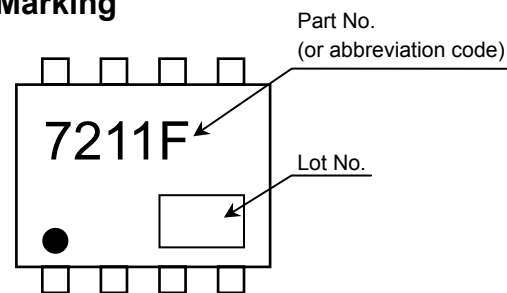

● on the lower left of the marking indicates Pin 1

*Weekly code: (Three digits)



Week of manufacture
(01 for first week of year, continuing up to 52 or 53)
Year of manufacture
(The last digit of the calendar year)

Please contact your TOSHIBA sales representative for details as to environmental matters such as the RoHS compatibility of Product.

The RoHS is the Directive 2002/95/EC of the European Parliament and of the Council of 27 January 2003 on the restriction of the use of certain

This product has a MOS structure and is sensitive electrostatic discharge.

Block Diagram / Application Circuit

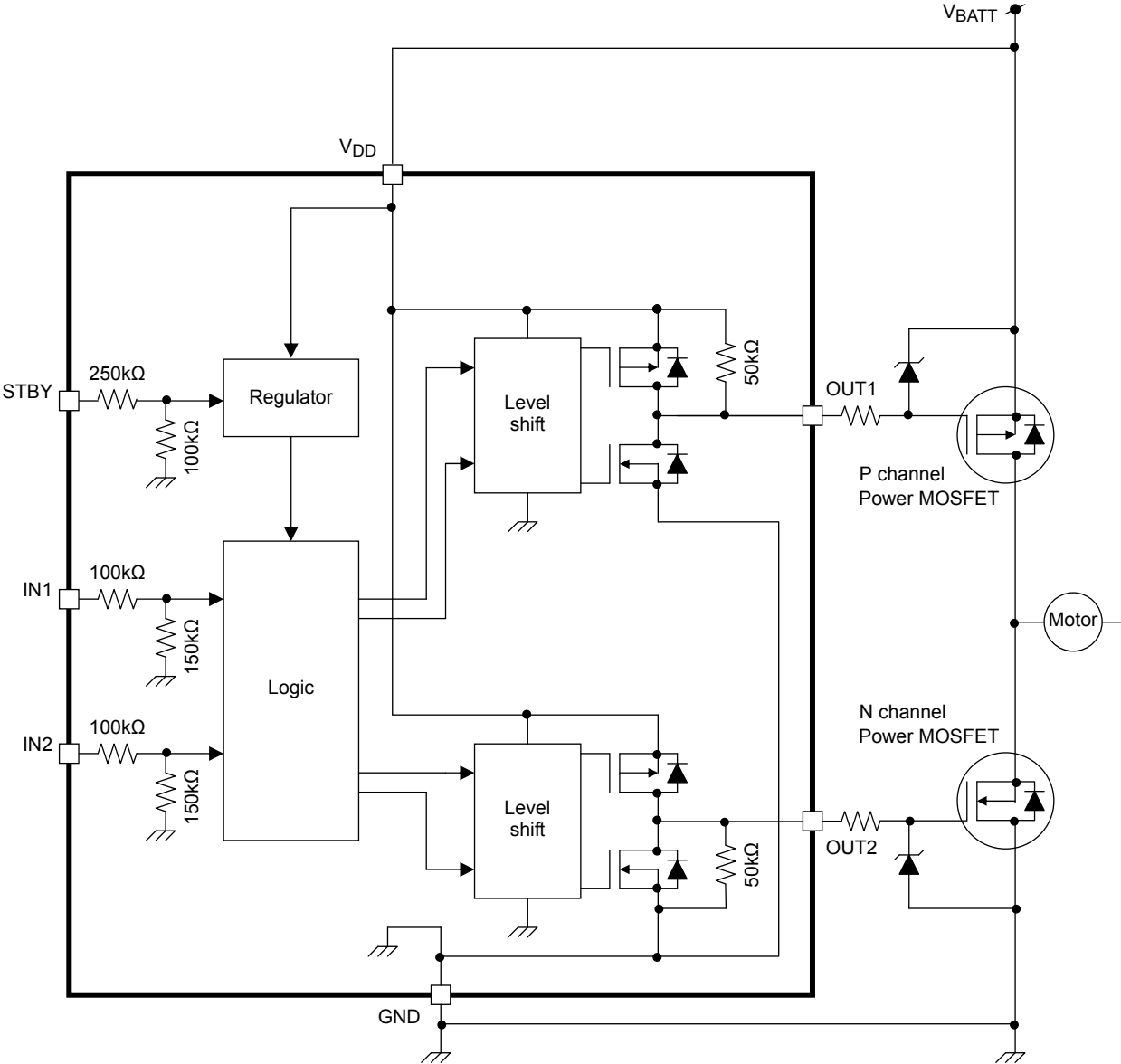

Pin Description

Pin No.	Symbol	Pin Description
1	IN1	Input pin for high-side output (OUT1) control. The IN1 pin has an internal pull-down resistor. Thus, even if the input is open-circuit, the OUT1 never turns on ("L") inadvertently.
2	STBY	Standby pin:By driving this pin "L", supply current is 10 μ A or less and all outputs can be turned off regardless of input signals. By driving this pin "H", all outputs are switching normally. The STBY pin has an internal pull-down resistor. When input is open circuit, this IC becomes the same operation as "L".
3	IN2	Input pin for low-side output (OUT2) control. The IN2 pin has an internal pull-down resistor. Thus, even if the input is open-circuit, the OUT2 never turns on ("H") inadvertently.
4	GND	Ground pin.
5	OUT2	Drives the low-side N channel power MOSFET.
6	N.C	No-Connect pin.
7	V _{DD}	Power supply pin.
8	OUT1	Drives the high-side P channel power MOSFET.

Absolute Maximum Ratings (Ta = 25°C)

Characteristics	Symbol	Pin	Rating	Unit	Remarks
Power supply voltage	V _{DD}	V _{DD}	-0.3 to 35	V	When V _{DD} range is 30V or more, Pulse width ≤ 0.3s
Input voltage	V _{IN}	IN1, IN2	-0.3 to 6	V	-
	V _{STBY}	STBY	-0.3 to 35	V	When V _{DD} range is 30V or more, Pulse width ≤ 0.3s
Output voltage	V _{OUT}	OUT1, OUT2	-0.3 to V _{DD} +0.3	V	Absolute Maximum Ratings is 35V or less. When V _{DD} range is 30V or more, Pulse width ≤ 0.3s
Output current	I _{OUT}	OUT1, OUT2	±500	mA	-
Power dissipation(Note 2)	P _{D(1)}	-	0.7	W	Refer to Note 2a
	P _{D(2)}	-	0.35	W	Refer to Note 2b
Operating temperature	T _{opr}	-	-40 to 125	°C	-
Junction temperature	T _j	-	150	°C	-
Storage temperature	T _{stg}	-	-40 to 150	°C	-

Note1: Using continuously under heavy loads (e.g. the application of high temperature/current/voltage and the significant change in temperature, etc.) may cause this product to decrease in the reliability significantly even if the operating conditions (i.e. operating temperature/current/voltage, etc.) are within the absolute maximum ratings and the operating ranges.

Please design the appropriate reliability upon reviewing the Toshiba Semiconductor Reliability Handbook ("Handling Precautions"/"Derating Concept and Methods") and individual reliability data (i.e. reliability test report and estimated failure rate, etc).

Thermal Resistance

Characteristic	Symbol	Rating	Unit
Junction to ambient thermal resistance	R _{th(j-a)}	178.6 (Note 2a)	°C / W
		357.2 (Note 2b)	

Note 2:

(a) Mounted on glass epoxy board

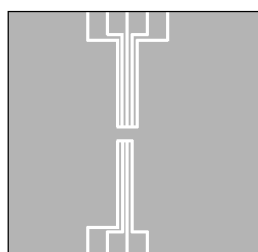

Glass epoxy board
Material : FR-4
25.4mm×25.4mm×0.8mm

(b) Mounted on glass epoxy board

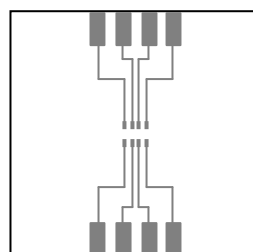

Glass epoxy board
Material : FR-4
25.4mm×25.4mm×0.8mm

Electrical Characteristics

(Unless otherwise specified, $T_j = -40$ to 125 °C, $V_{DD} = 5$ to 18 V, $V_{STBY} = 5$ V)

Characteristics	Symbol	Pin	Condition	Min	Typ.	Max	Unit
Operating supply voltage	$V_{DD(opr)}$	V_{DD}	-	5	12	18	V
Supply current	I_{DD1}	V_{DD}	$V_{STBY}=0V$, $V_{DD}=12V$, Output pin is open.	-	-	10	μA
	I_{DD2}	V_{DD}	$V_{STBY}=5V$, $V_{DD}=12V$, $V_{IN1,2}=0V$, Output pin is open.	-	-	3	mA
High level input voltage	V_{IH1}	IN1,IN2	-	3.5	-	-	V
	V_{IH2}	STBY		3.5	-	-	V
Low level input voltage	V_{IL1}	IN1,IN2		-	-	1.5	V
	V_{IL2}	STBY		-	-	0.8	V
High level input current	I_{IH1}	IN1,IN2	$V_{IN1,2}=5V$, per one input.	-	20	50	μA
	I_{IH2}	STBY	$V_{STBY}=5V$	-	15	50	μA
Low level input current	I_{IL1}	IN1,IN2	$V_{IN1,2}=0V$, per one input.	-0.2	-	+0.2	μA
	I_{IL2}	STBY	$V_{STBY}=0V$	-0.2	-	+0.2	μA
High-side(OUT1) high-level output voltage	V_{O1H}	OUT1	$V_{IN1}=0V$, $I_o=-10mA$	V_{DD} -0.2	-	-	V
High-side(OUT1) low-level output voltage	V_{O1L}	OUT1	$V_{IN1}=5V$, $I_o=+10mA$	-	-	0.2	V
Low-side(OUT2) high-level output voltage	V_{O2H}	OUT2	$V_{IN2}=5V$, $I_o=-10mA$	V_{DD} -0.2	-	-	V
Low-side(OUT2) low-level output voltage	V_{O2L}	OUT2	$V_{IN2}=0V$, $I_o=+10mA$	-	-	0.2	V
Output ON Resistance	$R_{DS(ON)[SOURCE]}$	OUT1, OUT2	$T_j=25^\circ C$, $I_o=-250mA$	-	4	8	Ω
	$R_{DS(ON)[SINK]}$	OUT1, OUT2	$T_j=25^\circ C$, $I_o=+250mA$	-	3	6	
Switching times	$t_{d(on)1}$	OUT1	$V_{DD}=12V$, $R_o=25\Omega$, $C_o=5000pF$	-	0.25	1	μs
	t_{ON1}			-	0.5	2	
	$t_{d(off)1}$			-	0.25	1	
	t_{OFF1}			-	0.5	2	
	$t_{d(on)2}$	OUT2		-	0.25	1	
	t_{ON2}			-	0.5	2	
	$t_{d(off)2}$			-	0.25	1	
	t_{OFF2}			-	0.5	2	
Dead times	t_{dead1}	OUT1, OUT2	$t_{d(off)1}-t_{d(on)2}$, $t_{d(off)2}-t_{d(on)1}$	-	-	1	μs
	t_{dead2}	OUT1, OUT2	$t_{d(off)1}-t_{d(on)1}$, $t_{d(off)2}-t_{d(on)2}$	-	-	1	

*Please set the deadtime of the input signal after considering the switching time of external power MOSFET.

*The condition of the typical value is $T_j=25^\circ C$, $V_{DD}=12V$.

Switching times test circuit

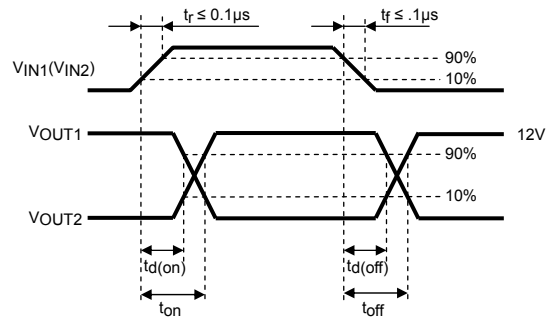
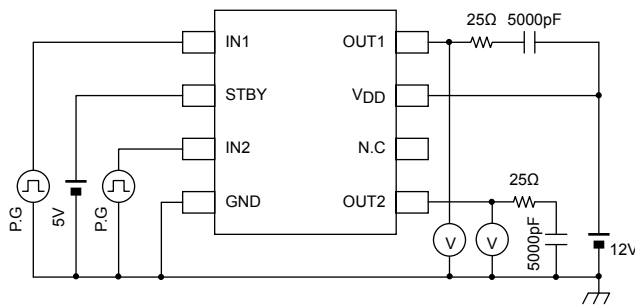

Timing chart

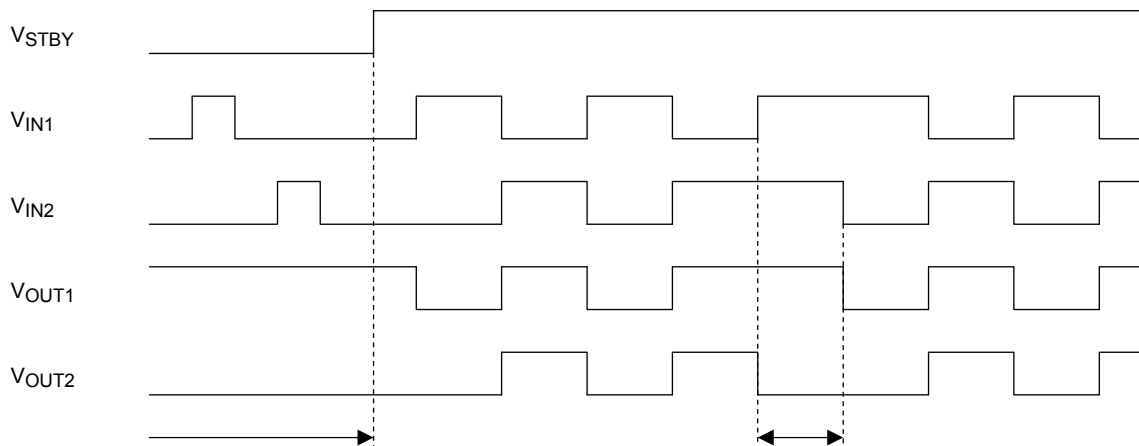

By driving STBY low, all output DMOS are turned off regardless of input signals.

Input that is High-side/Low-side arm shorting mode ($V_{IN1}=V_{IN2}=H$) is a prohibition mode. When it is prohibition mode, it is $V_{OUT1}=H$ and $V_{OUT2}=L$. (External MOSFETs are all off)

Truth Table

STBY signal	IN1 signal	IN2 signal	V _{OUT1}	V _{OUT2}	Remarks
L	L	L	H	L	Standby mode (Output is all off)
L	H	L	H	L	
L	L	H	H	L	
H	L	L	H	L	OUT1 and OUT2 are off mode. (External MOSFETs are all off mode)
H	H	L	L	L	OUT1 is on mode. (External high side MOSFET is on mode)
H	L	H	H	H	OUT2 is on mode. (External low side MOSFET is on mode)
H	H	H	H	L	High-side/Low-side arm shorting mode.

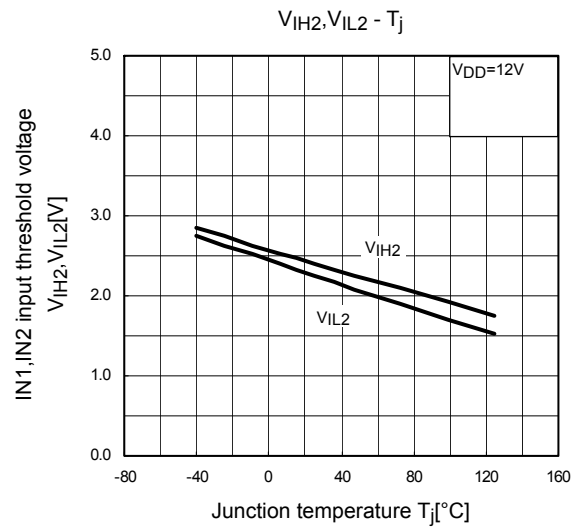
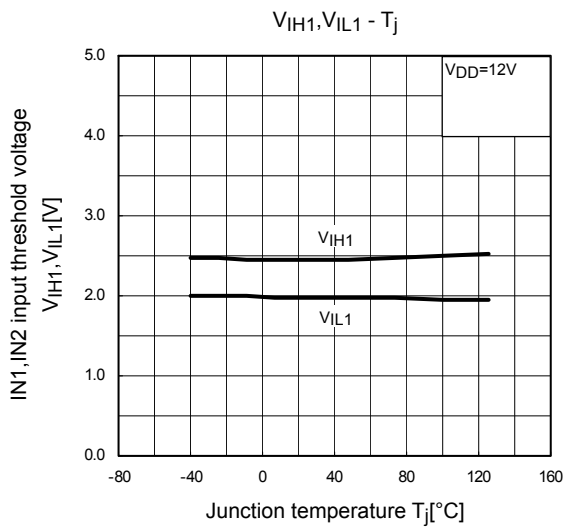
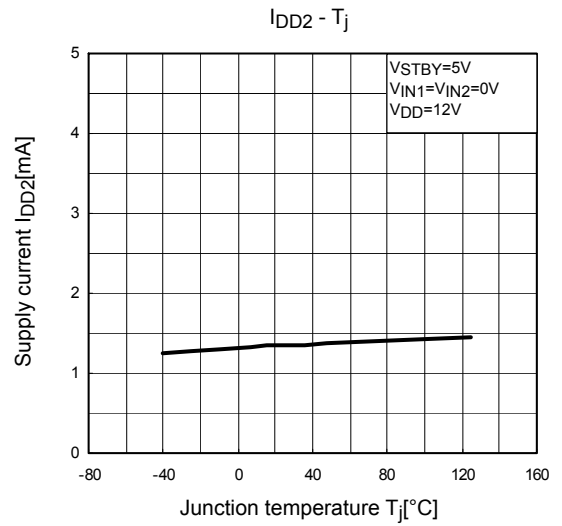
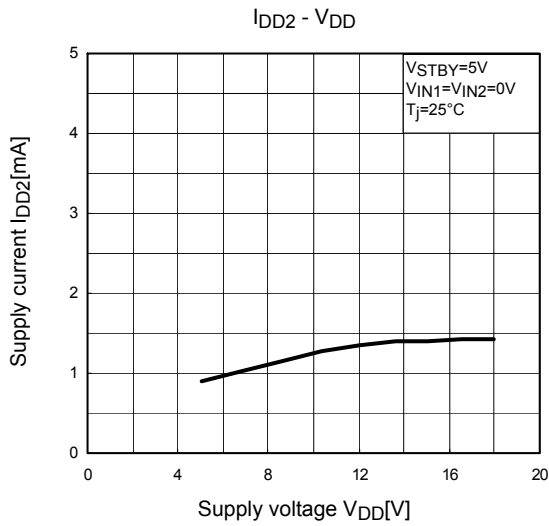
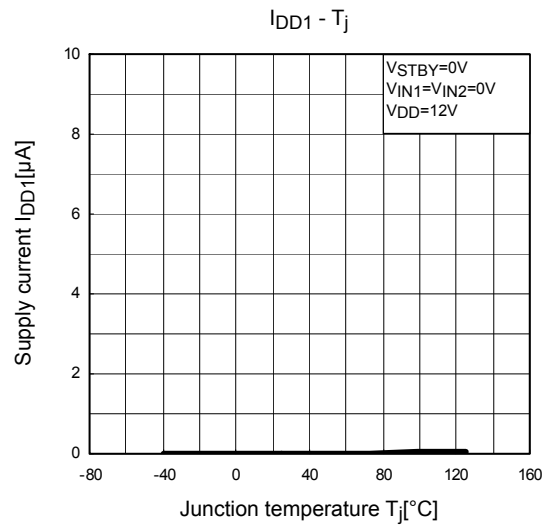
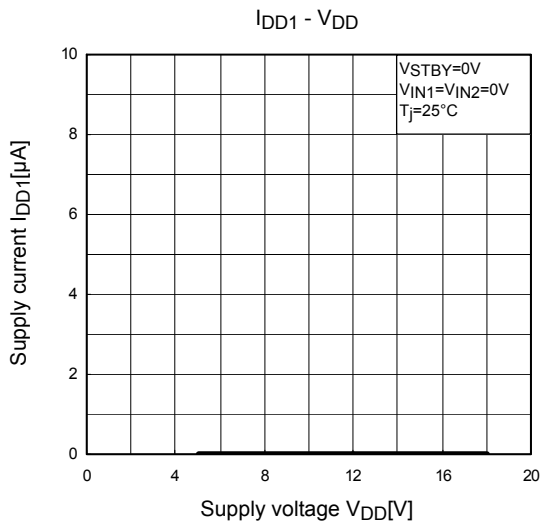

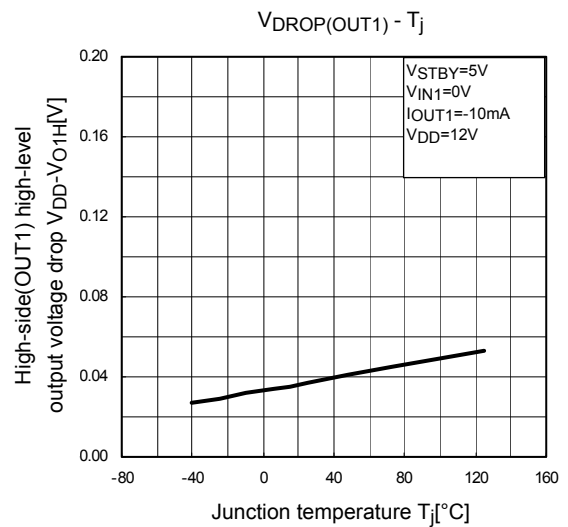
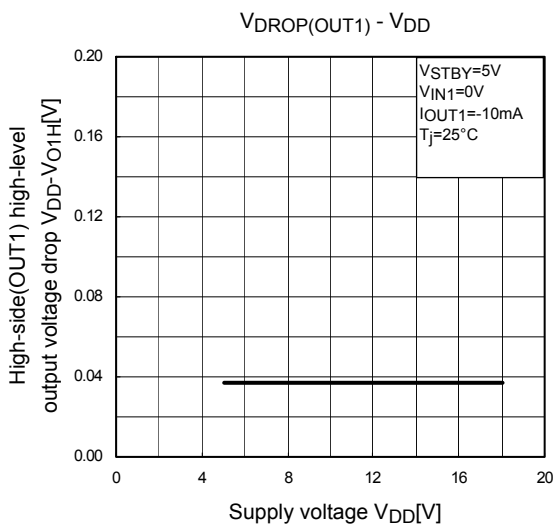
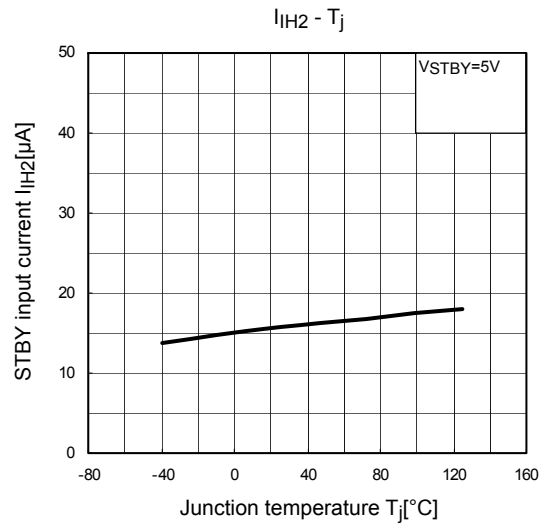
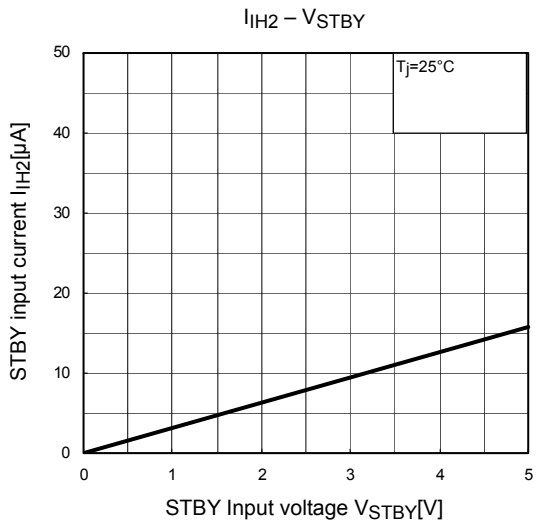
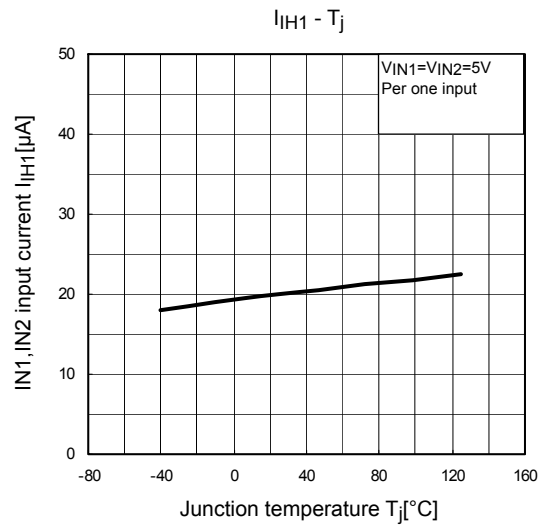
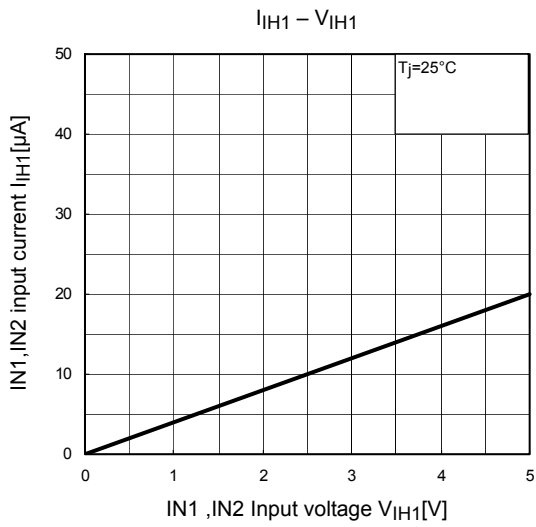

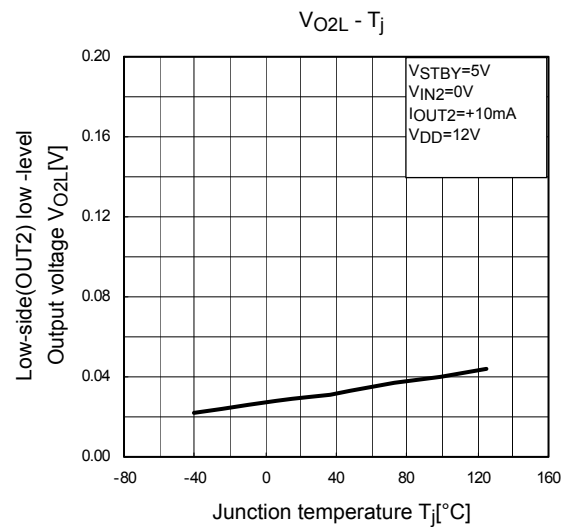
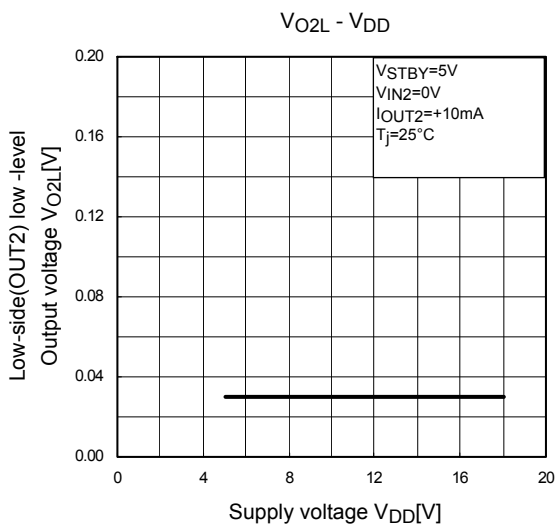
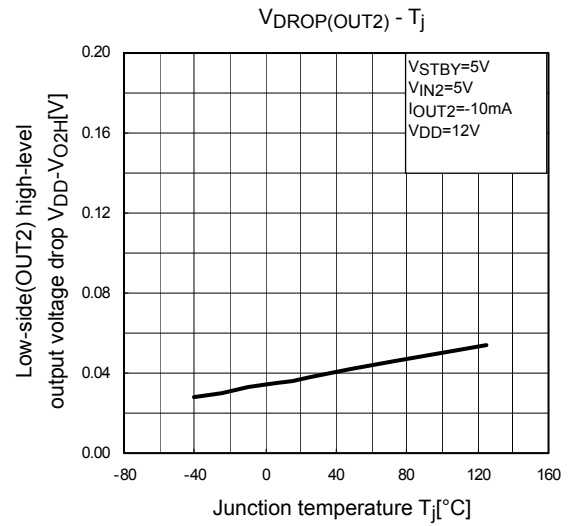
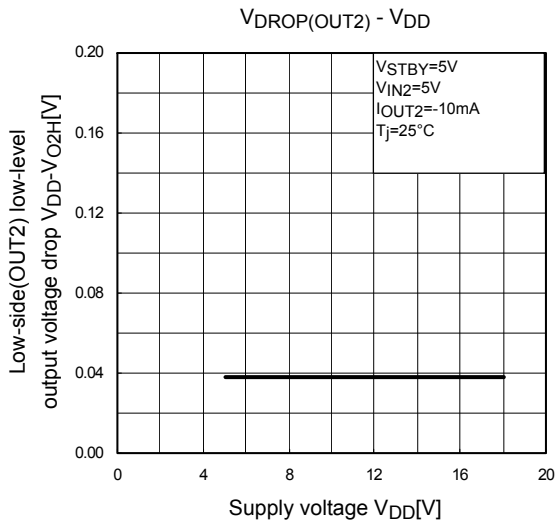
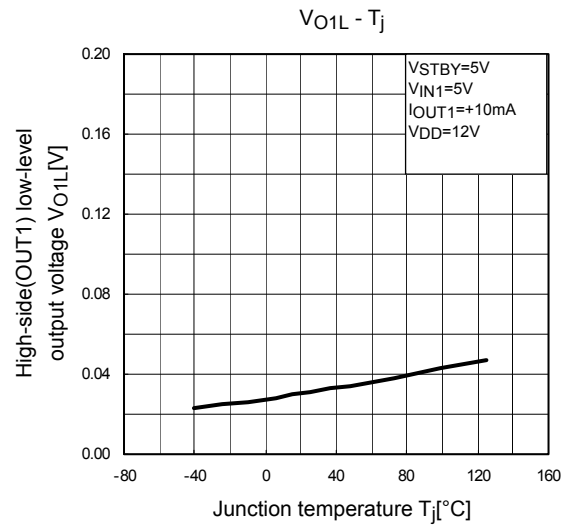
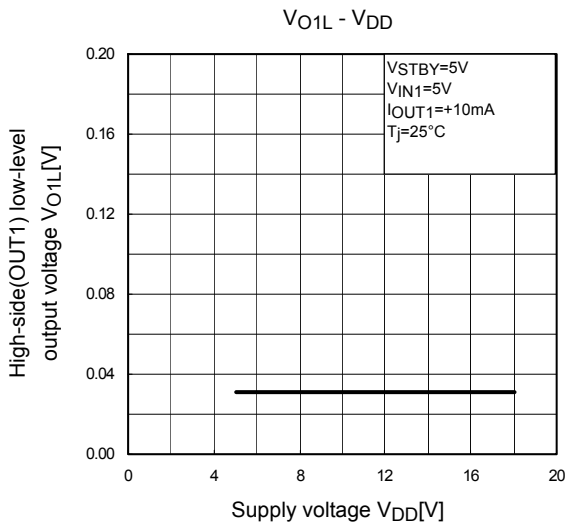

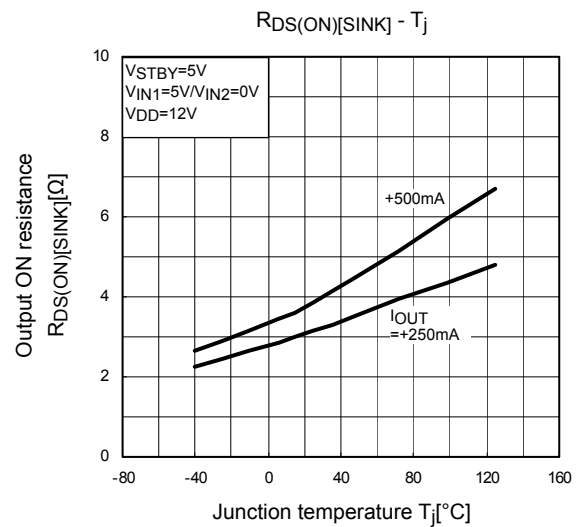
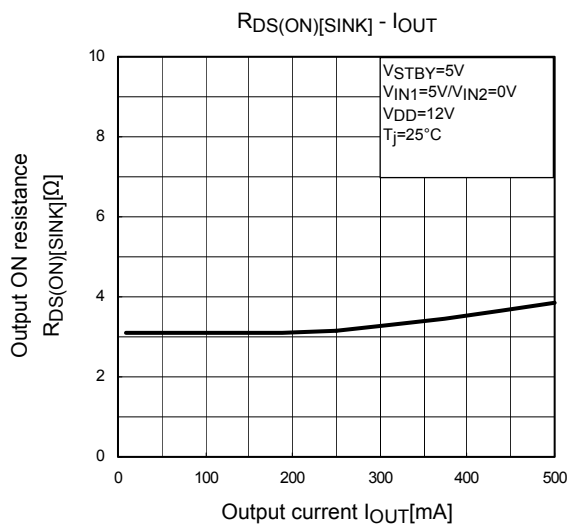
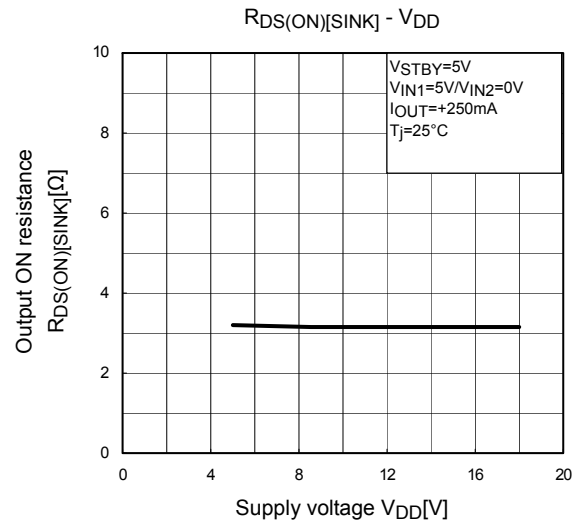
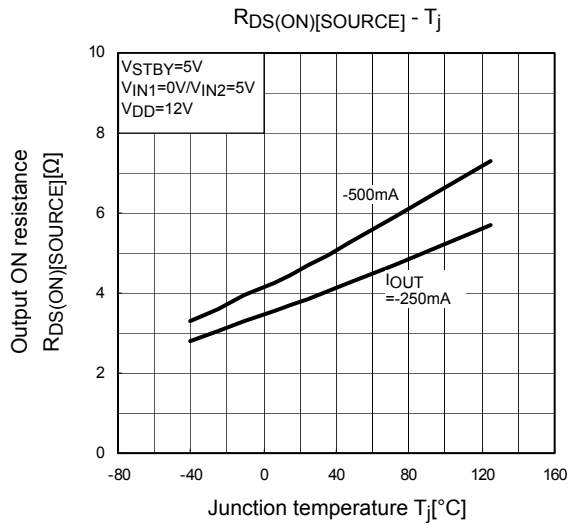
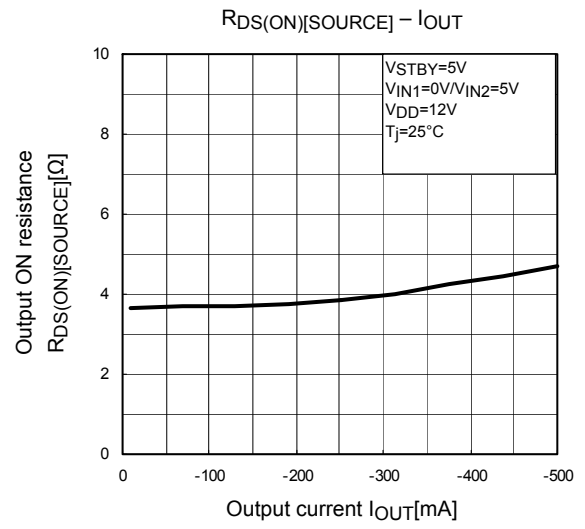
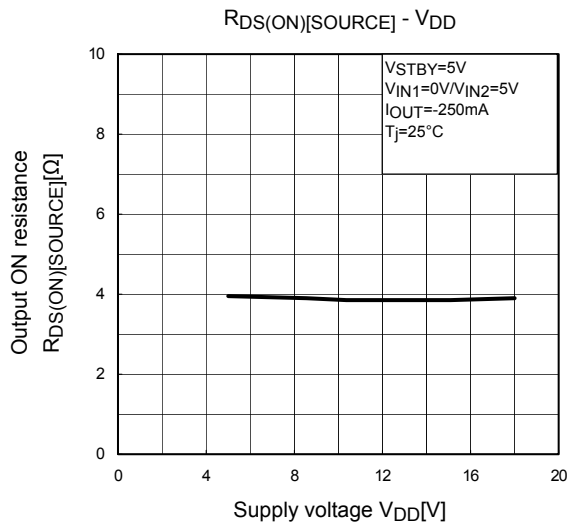

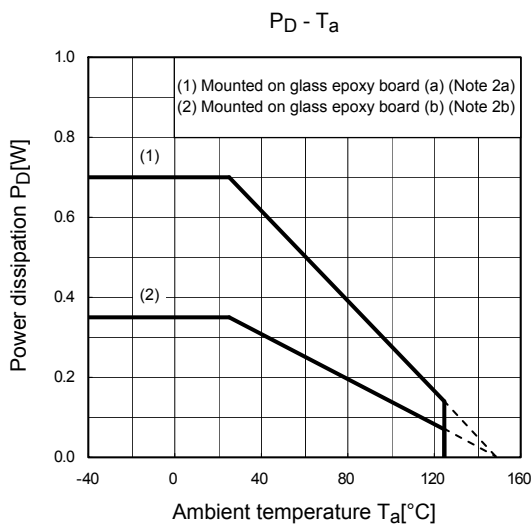
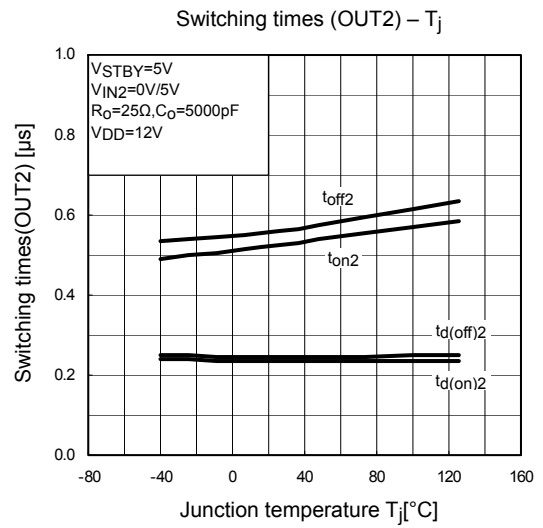
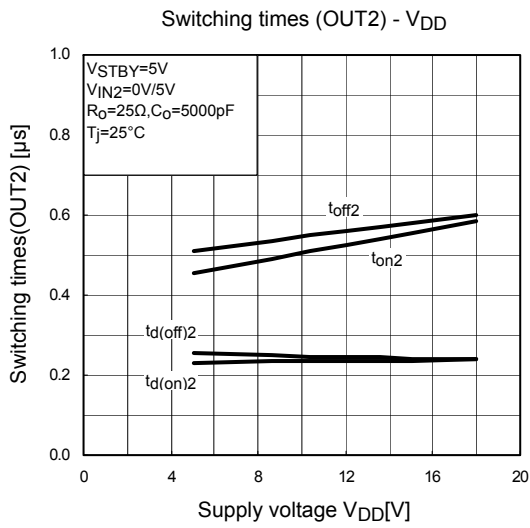
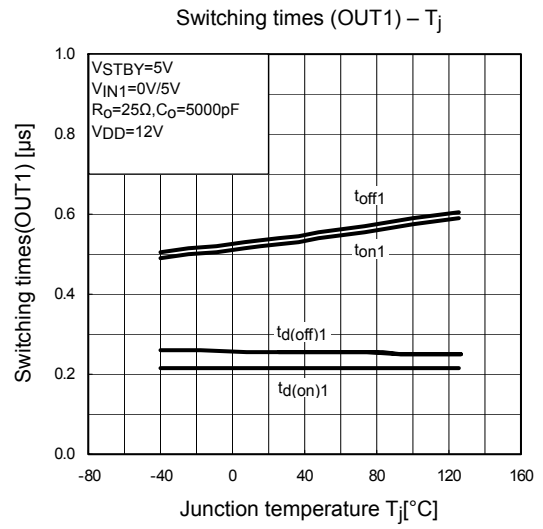
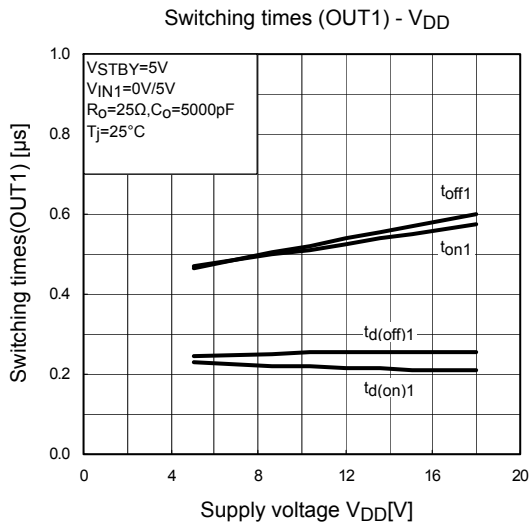

Package Dimensions

SON8-P-0303-0.65

Unit: mm

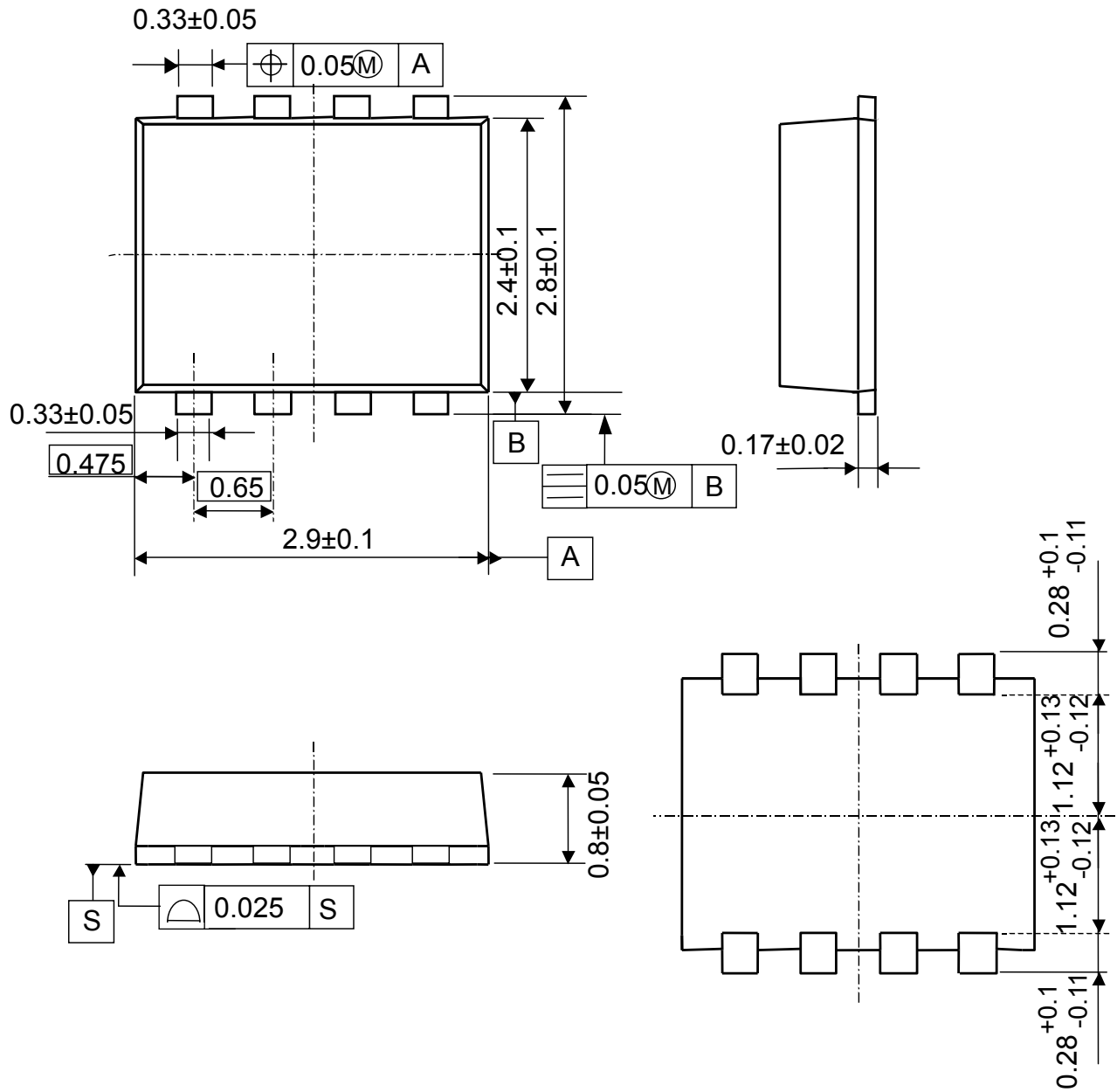

Weight: 0.017g(typ.)

RESTRICTIONS ON PRODUCT USE

- Toshiba Corporation, and its subsidiaries and affiliates (collectively "TOSHIBA"), reserve the right to make changes to the information in this document, and related hardware, software and systems (collectively "Product") without notice.
- This document and any information herein may not be reproduced without prior written permission from TOSHIBA. Even with TOSHIBA's written permission, reproduction is permissible only if reproduction is without alteration/omission.
- Though TOSHIBA works continually to improve Product's quality and reliability, Product can malfunction or fail. Customers are responsible for complying with safety standards and for providing adequate designs and safeguards for their hardware, software and systems which minimize risk and avoid situations in which a malfunction or failure of Product could cause loss of human life, bodily injury or damage to property, including data loss or corruption. Before customers use the Product, create designs including the Product, or incorporate the Product into their own applications, customers must also refer to and comply with (a) the latest versions of all relevant TOSHIBA information, including without limitation, this document, the specifications, the data sheets and application notes for Product and the precautions and conditions set forth in the "TOSHIBA Semiconductor Reliability Handbook" and (b) the instructions for the application with which the Product will be used with or for. Customers are solely responsible for all aspects of their own product design or applications, including but not limited to (a) determining the appropriateness of the use of this Product in such design or applications; (b) evaluating and determining the applicability of any information contained in this document, or in charts, diagrams, programs, algorithms, sample application circuits, or any other referenced documents; and (c) validating all operating parameters for such designs and applications. **TOSHIBA ASSUMES NO LIABILITY FOR CUSTOMERS' PRODUCT DESIGN OR APPLICATIONS.**
- Product is intended for use in general electronics applications (e.g., computers, personal equipment, office equipment, measuring equipment, industrial robots and home electronics appliances) or for specific applications as expressly stated in this document. Product is neither intended nor warranted for use in equipment or systems that require extraordinarily high levels of quality and/or reliability and/or a malfunction or failure of which may cause loss of human life, bodily injury, serious property damage or serious public impact ("Unintended Use"). Unintended Use includes, without limitation, equipment used in nuclear facilities, equipment used in the aerospace industry, medical equipment, equipment used for automobiles, trains, ships and other transportation, traffic signaling equipment, equipment used to control combustions or explosions, safety devices, elevators and escalators, devices related to electric power, and equipment used in finance-related fields. Do not use Product for Unintended Use unless specifically permitted in this document.
- Do not disassemble, analyze, reverse-engineer, alter, modify, translate or copy Product, whether in whole or in part.
- Product shall not be used for or incorporated into any products or systems whose manufacture, use, or sale is prohibited under any applicable laws or regulations.
- The information contained herein is presented only as guidance for Product use. No responsibility is assumed by TOSHIBA for any infringement of patents or any other intellectual property rights of third parties that may result from the use of Product. No license to any intellectual property right is granted by this document, whether express or implied, by estoppel or otherwise.
- **ABSENT A WRITTEN SIGNED AGREEMENT, EXCEPT AS PROVIDED IN THE RELEVANT TERMS AND CONDITIONS OF SALE FOR PRODUCT, AND TO THE MAXIMUM EXTENT ALLOWABLE BY LAW, TOSHIBA (1) ASSUMES NO LIABILITY WHATSOEVER, INCLUDING WITHOUT LIMITATION, INDIRECT, CONSEQUENTIAL, SPECIAL, OR INCIDENTAL DAMAGES OR LOSS, INCLUDING WITHOUT LIMITATION, LOSS OF PROFITS, LOSS OF OPPORTUNITIES, BUSINESS INTERRUPTION AND LOSS OF DATA, AND (2) DISCLAIMS ANY AND ALL EXPRESS OR IMPLIED WARRANTIES AND CONDITIONS RELATED TO SALE, USE OF PRODUCT, OR INFORMATION, INCLUDING WARRANTIES OR CONDITIONS OF MERCHANTABILITY, FITNESS FOR A PARTICULAR PURPOSE, ACCURACY OF INFORMATION, OR NONINFRINGEMENT.**
- Do not use or otherwise make available Product or related software or technology for any military purposes, including without limitation, for the design, development, use, stockpiling or manufacturing of nuclear, chemical, or biological weapons or missile technology products (mass destruction weapons). Product and related software and technology may be controlled under the Japanese Foreign Exchange and Foreign Trade Law and the U.S. Export Administration Regulations. Export and re-export of Product or related software or technology are strictly prohibited except in compliance with all applicable export laws and regulations.
- Please contact your TOSHIBA sales representative for details as to environmental matters such as the RoHS compatibility of Product. Please use Product in compliance with all applicable laws and regulations that regulate the inclusion or use of controlled substances, including without limitation, the EU RoHS Directive. TOSHIBA assumes no liability for damages or losses occurring as a result of noncompliance with applicable laws and regulations.