

TOSHIBA Intelligent Power Device
High Voltage Monolithic Silicon Power IC

TPD4144AK

The TPD4144AK is a DC brush less motor driver using high voltage PWM control. It is fabricated by high voltage SOI process. It is three-shunt resistor circuit for current sensing. It contains level shift high-side driver, low-side driver, IGBT outputs, FRDs and protective functions for under voltage protection circuits and thermal shutdown circuit. It is easy to control a DC brush less motor by just putting logic inputs from a MPU or motor controller to the TPD4144AK.

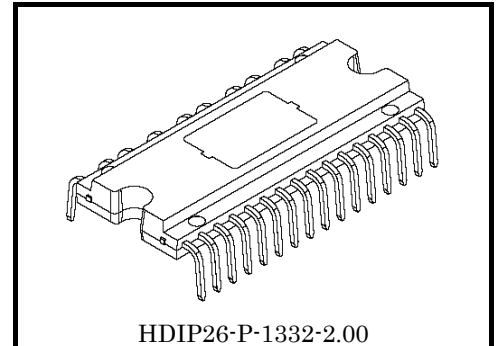

Weight: 3.8 g (typ.)

Features

- High voltage power side and low voltage signal side terminal are separated.
- It is the best for current sensing in three shunt resistance.
- Bootstrap circuit gives simple high-side supply.
- Bootstrap diodes are built in.
- A dead time can be set as a minimum of 1.4 μ s, and it is the best for a Sine-wave from drive.
- 3-phase bridge output using IGBTs.
- FRDs are built in.
- Included under voltage protection and thermal shutdown.
- The regulator of 7V (typ.) is built in.
- Package: 26-pin DIP.

This product has a MOS structure and is sensitive to electrostatic discharge. When handling this product, ensure that the environment is protected against electrostatic discharge.

Pin Assignment

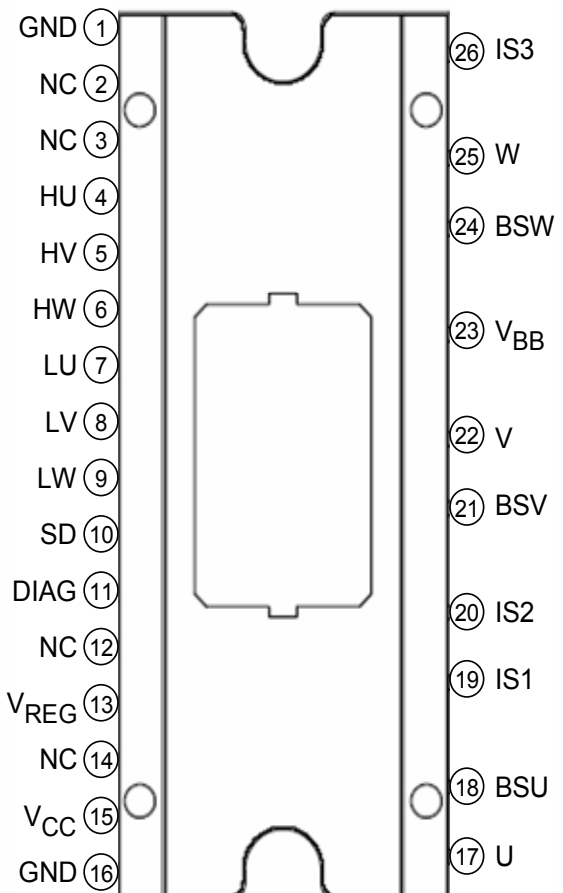

Marking

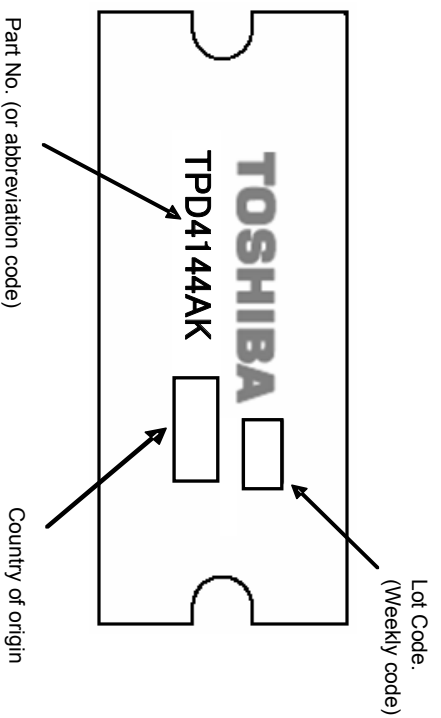

Pin Description

Pin No.	Symbol	Pin Description
1	GND	Ground pin.
2	NC	Unused pin, which is not connected to the chip internally.
3	NC	Unused pin, which is not connected to the chip internally.
4	HU	The control terminal of IGBT by the high side of U. It turns off less than 1.5V. It turns on more than 2.5V.
5	HV	The control terminal of IGBT by the high side of V. It turns off less than 1.5V. It turns on more than 2.5V.
6	HW	The control terminal of IGBT by the high side of W. It turns off less than 1.5V. It turns on more than 2.5V.
7	LU	The control terminal of IGBT by the low side of U. It turns off less than 1.5V. It turns on more than 2.5V.
8	LV	The control terminal of IGBT by the low side of V. It turns off less than 1.5V. It turns on more than 2.5V.
9	LW	The control terminal of IGBT by the low side of W. It turns off less than 1.5V. It turns on more than 2.5V.
10	SD	Input pin of external protection. ("L" active, It doesn't have hysteresis.)
11	DIAG	With the diagnostic output terminal of open drain, a pull-up is carried out by resistance. It turns on at the time of unusual.
12	NC	Unused pin, which is not connected to the chip internally.
13	V _{REG}	7V regulator output pin.
14	NC	Unused pin, which is not connected to the chip internally.
15	V _{CC}	Control power supply pin.(15V typ.)
16	GND	Ground pin.
17	U	U-phase output pin.
18	BSU	U-phase bootstrap capacitor connecting pin.
19	IS1	U-phase IGBT emitter and FRD anode pin.
20	IS2	V-phase IGBT emitter and FRD anode pin.
21	BSV	V-phase bootstrap capacitor connecting pin.
22	V	V-phase output pin.
23	V _{BB}	High-voltage power supply input pin.
24	BSW	W-phase bootstrap capacitor connecting pin.
25	W	W-phase output pin.
26	IS3	W-phase IGBT emitter and FRD anode pin.

Equivalent Circuit of Input Pins

Internal circuit diagram of HU, HV, HW, LU, LV, LW input pins

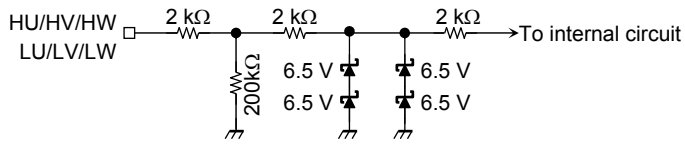

Internal circuit diagram of SD pin

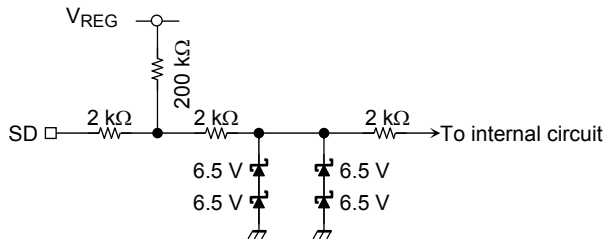

Internal circuit diagram of DIAG pin

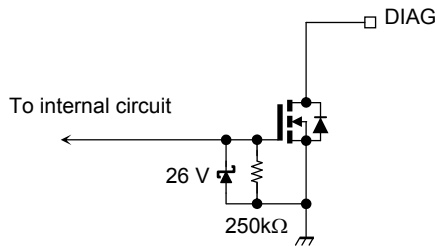

Timing Chart

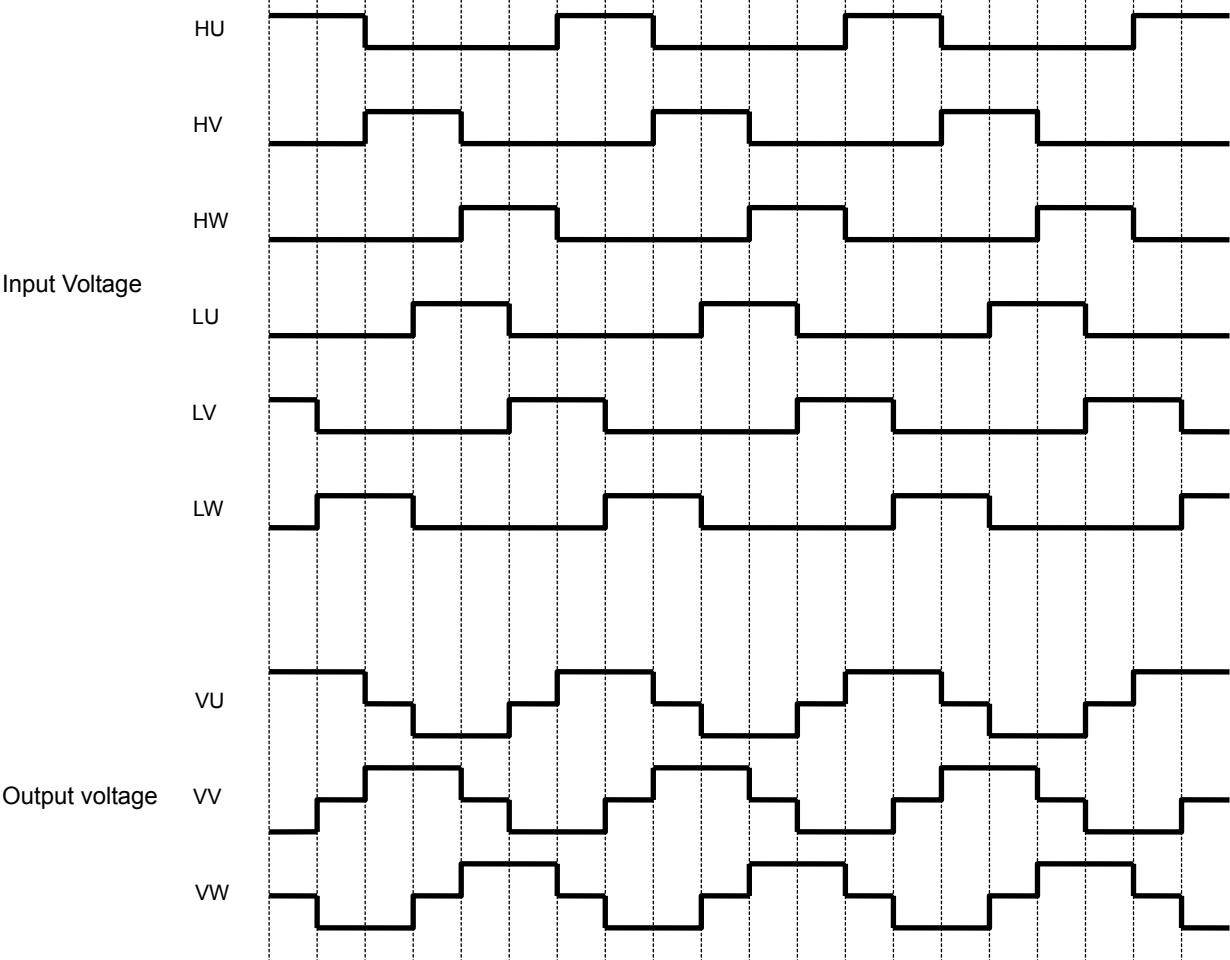

Truth Table

Mode	Input							High side			Low side			DIAG
	HU	HV	HW	LU	LV	LW	SD	U phase	V phase	W phase	U phase	V phase	W phase	
Normal	H	L	L	L	H	L	H	ON	OFF	OFF	OFF	ON	OFF	OFF
	H	L	L	L	L	H	H	ON	OFF	OFF	OFF	OFF	ON	OFF
	L	H	L	L	L	H	H	OFF	ON	OFF	OFF	OFF	ON	OFF
	L	H	L	H	L	L	H	OFF	ON	OFF	ON	OFF	OFF	OFF
	L	L	H	H	L	L	H	OFF	OFF	ON	ON	OFF	OFF	OFF
	L	L	H	L	H	L	H	OFF	OFF	ON	OFF	ON	OFF	OFF
Thermal shutdown	H	L	L	L	H	L	H	OFF	OFF	OFF	OFF	OFF	OFF	ON
	H	L	L	L	L	H	H	OFF	OFF	OFF	OFF	OFF	OFF	ON
	L	H	L	L	L	H	H	OFF	OFF	OFF	OFF	OFF	OFF	ON
	L	H	L	H	L	L	H	OFF	OFF	OFF	OFF	OFF	OFF	ON
	L	L	H	H	L	L	H	OFF	OFF	OFF	OFF	OFF	OFF	ON
V _{CC} Under-voltage	H	L	L	L	H	L	H	OFF	OFF	OFF	OFF	OFF	OFF	ON
	H	L	L	L	L	H	H	OFF	OFF	OFF	OFF	OFF	OFF	ON
	L	H	L	L	L	H	H	OFF	OFF	OFF	OFF	OFF	OFF	ON
	L	H	L	H	L	L	H	OFF	OFF	OFF	OFF	OFF	OFF	ON
	L	L	H	H	L	L	H	OFF	OFF	OFF	OFF	OFF	OFF	ON
	L	L	H	L	H	L	H	OFF	OFF	OFF	OFF	OFF	OFF	ON
V _{BS} Under-voltage	H	L	L	L	H	L	H	OFF	OFF	OFF	OFF	ON	OFF	OFF
	H	L	L	L	L	H	H	OFF	OFF	OFF	OFF	OFF	ON	OFF
	L	H	L	L	L	H	H	OFF	OFF	OFF	OFF	OFF	ON	OFF
	L	H	L	H	L	L	H	OFF	OFF	OFF	ON	OFF	OFF	OFF
	L	L	H	H	L	L	H	OFF	OFF	OFF	ON	OFF	OFF	OFF
	L	L	H	L	H	L	H	OFF	OFF	OFF	OFF	ON	OFF	OFF
SD	*	*	*	*	*	*	L	OFF	OFF	OFF	OFF	OFF	OFF	ON

Absolute Maximum Ratings (Ta = 25°C)

Characteristics	Symbol	Rating	Unit
Power supply voltage	V _{BB}	500	V
	V _{CC}	18	V
Output current (DC)	I _{out}	2	A
Output current (pulse 1ms)	I _{outp}	3	A
Input voltage	V _{IN}	-0.5 to 7	V
V _{REG} current	I _{REG}	50	mA
DIAG voltage	V _{DIAG}	20	V
DIAG current	I _{DIAG}	20	mA
Power dissipation (IGBT 1 phase (Tc = 25°C))	P _{C(IGBT)}	36	W
Power dissipation (FRD1 phase (Tc = 25°C))	P _{C(FRD)}	22	W
Operating junction temperature	T _{jopr}	-40 to 135	°C
Junction temperature	T _j	150	°C
Storage temperature	T _{stg}	-55 to 150	°C

Note: Using continuously under heavy loads (e.g. the application of high temperature/current/voltage and the significant change in temperature, etc.) may cause this product to decrease in the reliability significantly even if the operating conditions (i.e. operating temperature/current/voltage, etc.) are within the absolute maximum ratings and the operating ranges.

Please design the appropriate reliability upon reviewing the Toshiba Semiconductor Reliability Handbook (“Handling Precautions”/“Derating Concept and Methods”) and individual reliability data (i.e. reliability test report and estimated failure rate, etc).

Electrical Characteristics (Ta = 25°C)

Characteristics	Symbol	Test Condition	Min	Typ.	Max	Unit
Operating power supply voltage	V _{BB}	—	50	280	450	V
	V _{CC}	—	13.5	15	16.5	
Current dissipation	I _{BB}	V _{BB} = 450 V	—	—	0.5	mA
	I _{CC}	V _{CC} = 15 V	—	0.8	5	
Bootstrap Current dissipation	I _{BS} (ON)	V _{BS} = 15 V, high side ON	—	210	410	μA
	I _{BS} (OFF)	V _{BS} = 15 V, high side OFF	—	180	370	
Input voltage	V _{IH}	V _{IN} = "H", V _{CC} = 15 V	2.5	—	—	V
	V _{IL}	V _{IN} = "L", V _{CC} = 15 V	—	—	1.5	
SD input voltage	V _{SD}	V _{CC} = 15 V	—	2.5	—	V
Input current	I _{IH}	V _{IN} = 5 V	—	—	150	μA
	I _{IL}	V _{IN} = 0 V	—	—	100	
SD Input current	I _{SDH}	V _{IN} = 5 V	—	—	100	μA
	I _{SDL}	V _{IN} = 0 V	—	—	150	
Output saturation voltage	V _{CEsatH}	V _{CC} = 15 V, I _C = 1 A, high side	—	2.3	3.2	V
	V _{CEsatL}	V _{CC} = 15 V, I _C = 1 A, low side	—	2.3	3.2	
FRD forward voltage	V _{FH}	I _F = 1 A, high side	—	2.1	3.1	V
	V _{FL}	I _F = 1 A, low side	—	2.1	3.1	
BSD forward voltage	V _F (BSD)	I _F = 500 μA	—	0.8	1.2	V
Regulator voltage	V _{REG}	V _{CC} = 15 V, I _{REG} = 30 mA	6.5	7	7.5	V
Thermal shutdown temperature	TSD	V _{CC} = 15 V	135	—	185	°C
Thermal shutdown hysteresis	ΔTSD	V _{CC} = 15 V	—	50	—	°C
V _{CC} under voltage protection	V _{CCUVD}	—	10	11	12	V
V _{CC} under voltage protection recovery	V _{CCUVR}	—	10.5	11.5	12.5	V
V _{BS} under voltage protection	V _{BSUVD}	—	8	9	9.5	V
V _{BS} under voltage protection recovery	V _{BSUVR}	—	8.5	9.5	10.5	V
DIAG saturation voltage	V _{DIAGsat}	I _{DIAG} = 5 mA	—	—	0.5	V
Output on delay time	t _{on}	V _{BB} = 280 V, V _{CC} = 15 V, I _C = 1 A	—	1.2	3	μs
Output off delay time	t _{off}	V _{BB} = 280 V, V _{CC} = 15 V, I _C = 1 A	—	1	3	μs
Dead time	t _{dead}	V _{BB} = 280 V, V _{CC} = 15 V, I _C = 1 A	1.4	—	—	μs
FRD reverse recovery time	t _{rr}	V _{BB} = 280 V, V _{CC} = 15 V, I _C = 1 A	—	150	—	ns

Application Circuit Example

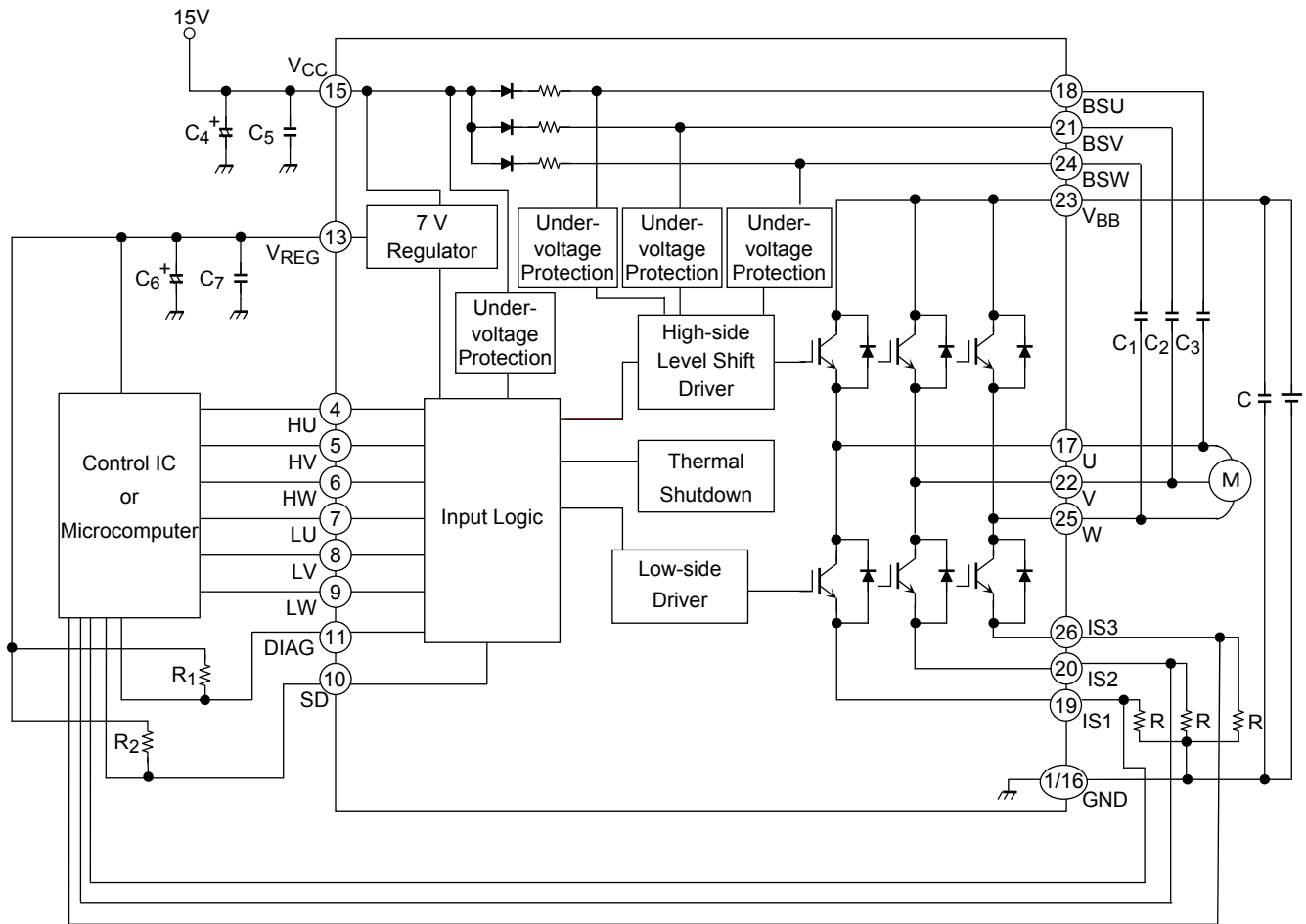

External Parts

Typical external parts are shown in the following table.

Part	Typical	Purpose	Remarks
C ₁ , C ₂ , C ₃	25 V/2.2 μF	Bootstrap capacitor	(Note 1)
C ₄	25 V/10 μF	V _{CC} power supply stability	(Note 2)
C ₅	25 V/0.1 μF	V _{CC} for surge absorber	(Note 2)
C ₆	25 V/1 μF	V _{REG} power supply stability	(Note 2)
C ₇	25 V/1000 pF	V _{REG} for surge absorber	(Note 2)
R ₁	5.1 kΩ	DIAG pin pull-up resistor	(Note 3)
R ₂	10 kΩ	SD pin pull-up resistor	-

Note 1: The required bootstrap capacitance value varies according to the motor drive conditions. The capacitor is biased by V_{CC} and must be sufficiently derated for it.

Note 2: When using this product, adjustment is required in accordance with the use environment. When mounting, place as close to the base of this product leads as possible to improve the ripple and noise elimination.

Note 3: The DIAG pin is open drain. If not using the DIAG pin, connect to the GND.

Handling precautions

- (1) Please control the input signal in the state to which the V_{CC} voltage is steady. Both of the order of the V_{BB} power supply and the V_{CC} power supply are not cared about either.
Note that if the power supply is switched off as described above, this product may be destroyed if the current regeneration route to the V_{BB} power supply is blocked when the V_{BB} line is disconnected by a relay or similar while the motor is still running.
- (2) The excess voltage such as the voltage surge which exceed the absolute maximum rating is added, for example, may destroy the circuit. Accordingly, be careful of handling this product or of surge voltage in its application environment.

Description of Protection Function

(1) Under voltage protection

This product incorporates under voltage protection circuits to prevent the IGBT from operating in unsaturated mode when the VCC voltage or the VBS voltage drops.

When the VCC power supply falls to this product internal setting VCCUVD (=11 V typ.), all IGBT outputs shut down regardless of the input. This protection function has hysteresis. When the VCC power supply reaches 0.5 V higher than the shutdown voltage (VCCUVR (=11.5 V typ.)), this product is automatically restored and the IGBT is turned on again by the input. DIAG output is reversed at the time of VCC under-voltage protection. When the VCC power supply is less than 7 V, DIAG output isn't sometimes reversed.

When the VBS supply voltage drops VBSUVD (=9 V typ.), the high-side IGBT output shuts down.

When the VBS supply voltage reaches 0.5 V higher than the shutdown voltage (VBSUVR (=9.5 V typ.)), the IGBT is turned on again by the input signal.

(2) Thermal shutdown

This product incorporates a thermal shutdown circuit to protect itself against the abnormal state when its temperature rises excessively.

When the temperature of this chip rises to the internal setting TSD due to external causes or internal heat generation, all IGBT outputs shut down regardless of the input. This protection function has hysteresis ΔTSD (=50 °C typ.). When the chip temperature falls to TSD - ΔTSD , the chip is automatically restored and the IGBT is turned on again by the input.

Because the chip contains just one temperature detection location, when the chip heats up due to the IGBT, for example, the differences in distance from the detection location in the IGBT (the source of the heat) cause differences in the time taken for shutdown to occur. Therefore, the temperature of the chip may rise higher than the thermal shutdown temperature when the circuit started to operate.

(3) SD pin

SD pin is the input signal pin to shut down the internal output IGBT. Output of all IGBT is shut down after delay times (2 μ s typ.) when "L" signal is input to the SD pin from external circuit (MCU etc.). It is possible to shut down IC when overcurrent and others is detected by external circuit. Shut down state is released by all of IC input signal "L". At open state of SD pin, shut down function can not operate.

Timing Chart of Under voltage protection and SD Function

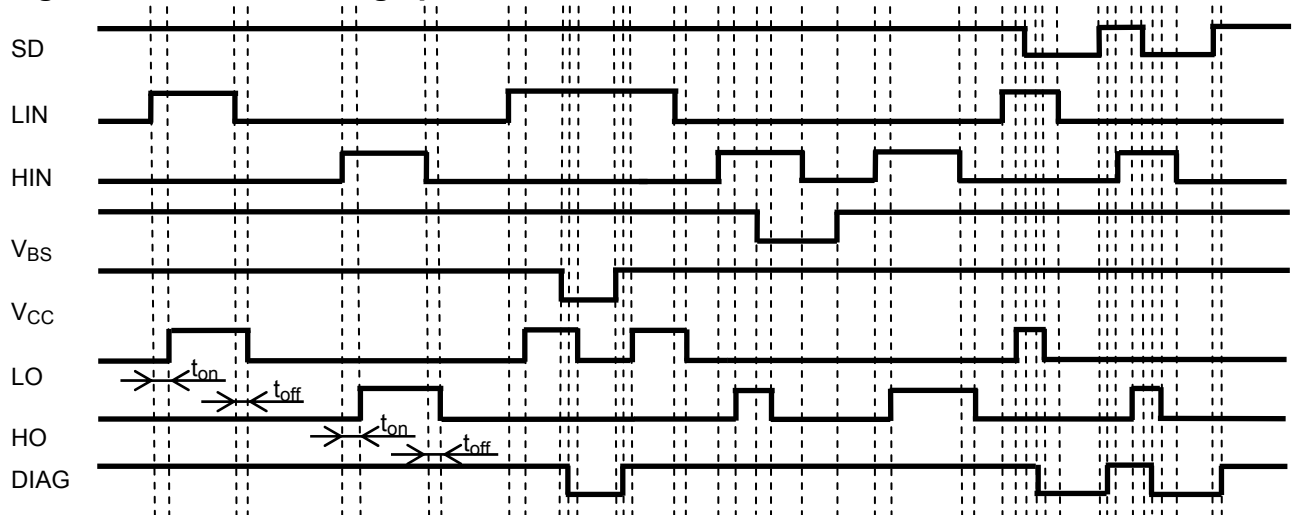

Note: The above timing chart is considering the delay time.

Safe Operating Area

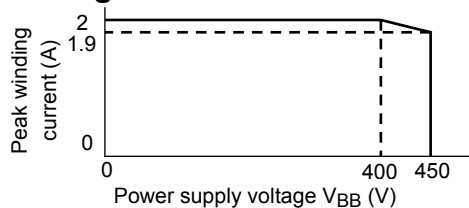
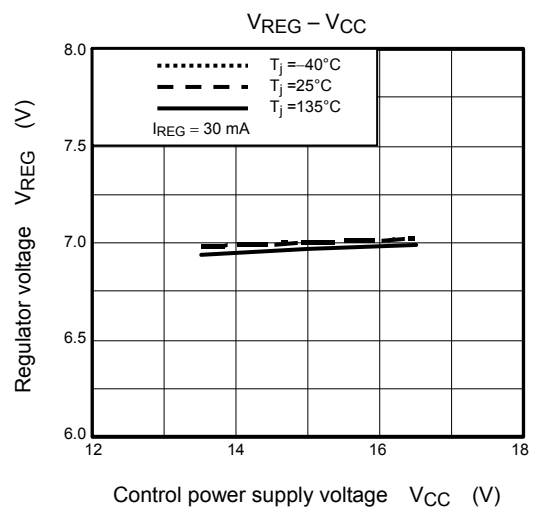
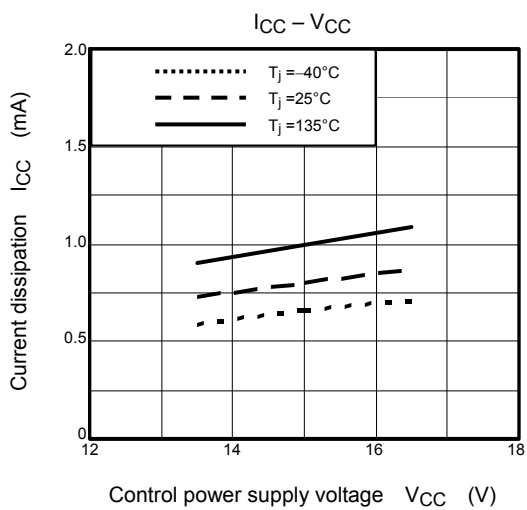
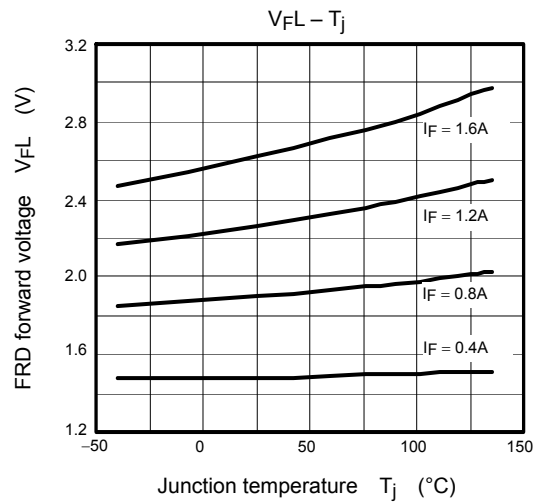
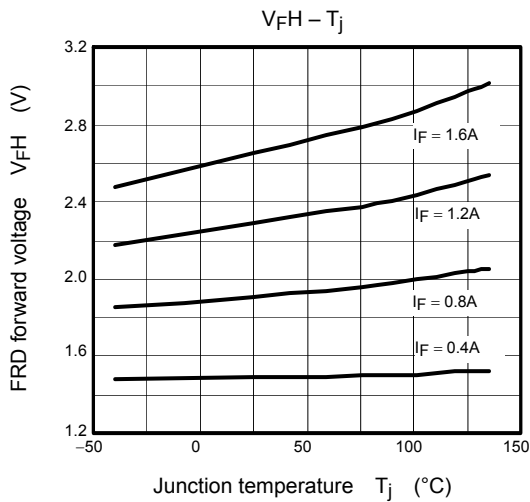
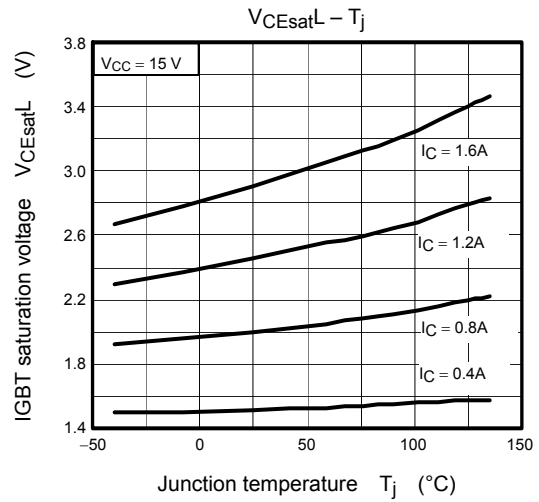
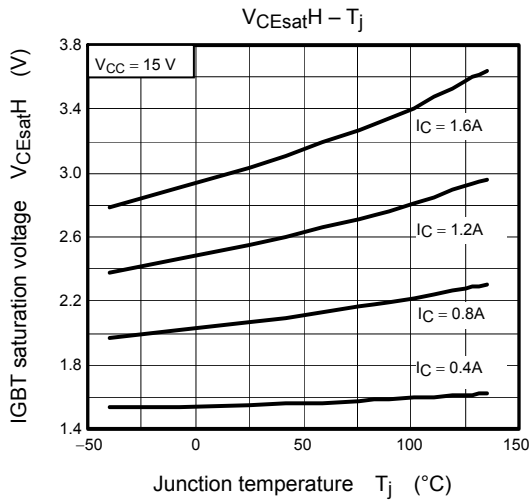
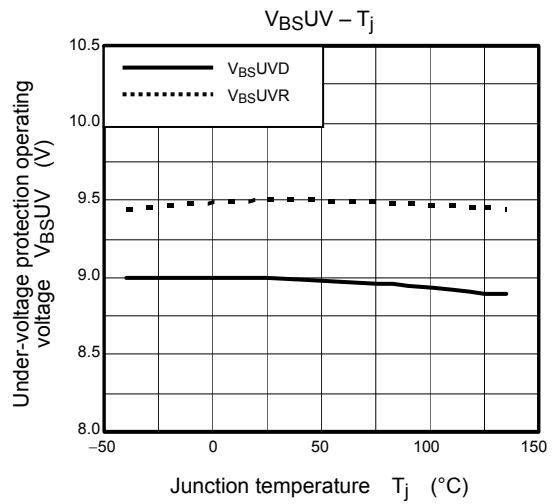
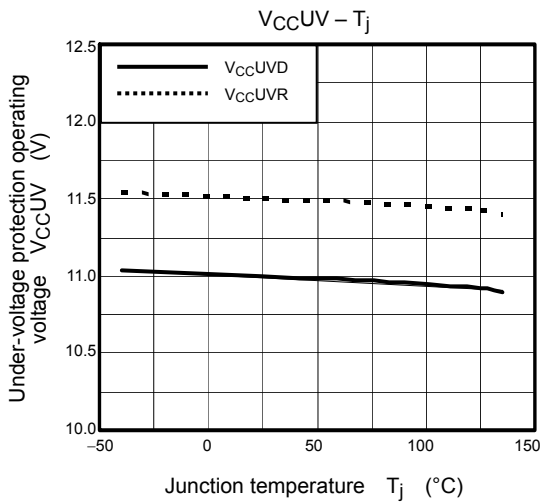
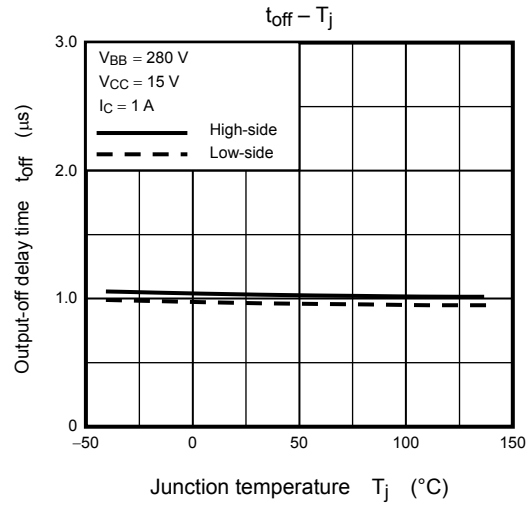
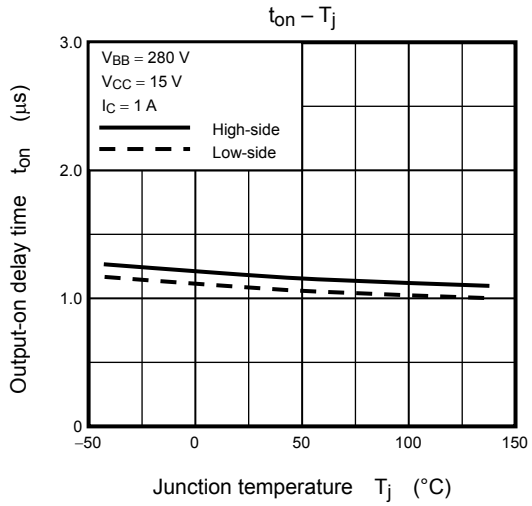
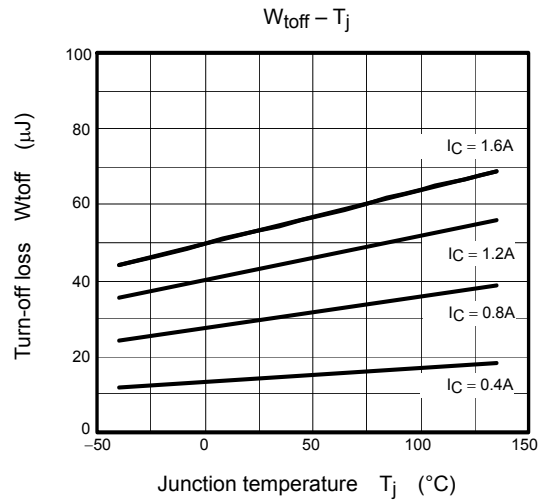
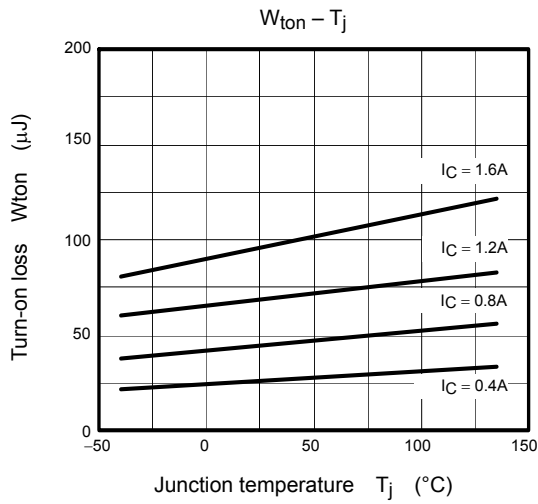
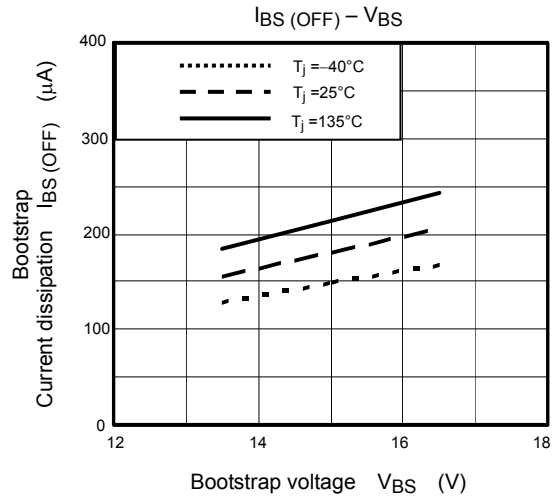
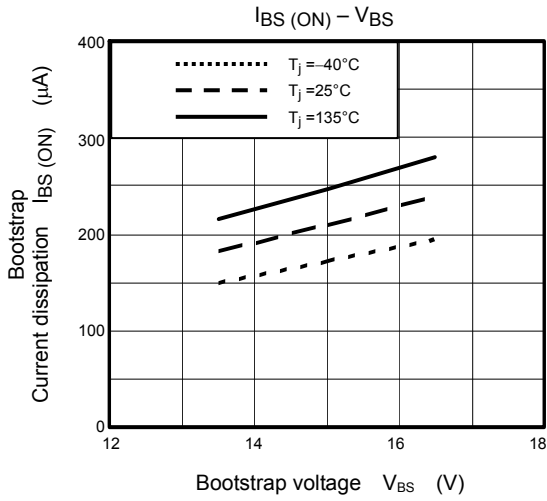

Figure 1 SOA at T_j = 135 °C

Note 1: The above safe operating areas are T_j = 135 °C (Figure 1).







Test Circuits

IGBT Saturation Voltage (U-phase low side)

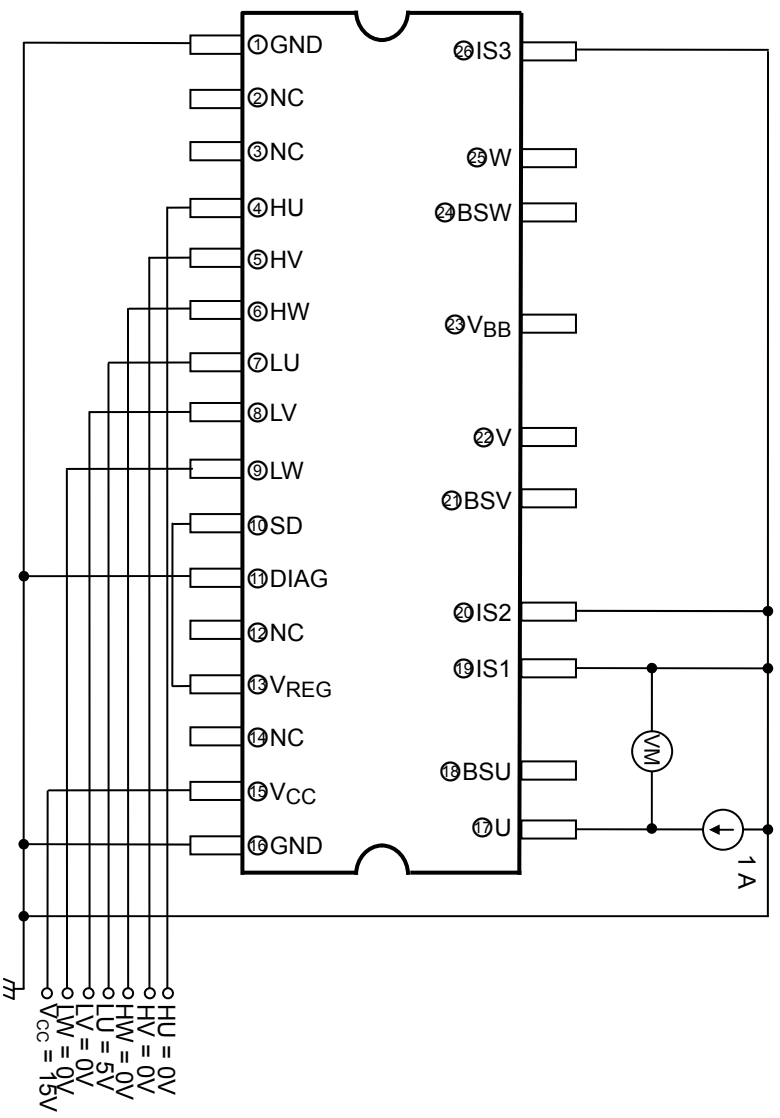

FRD Forward Voltage (U-phase low side)

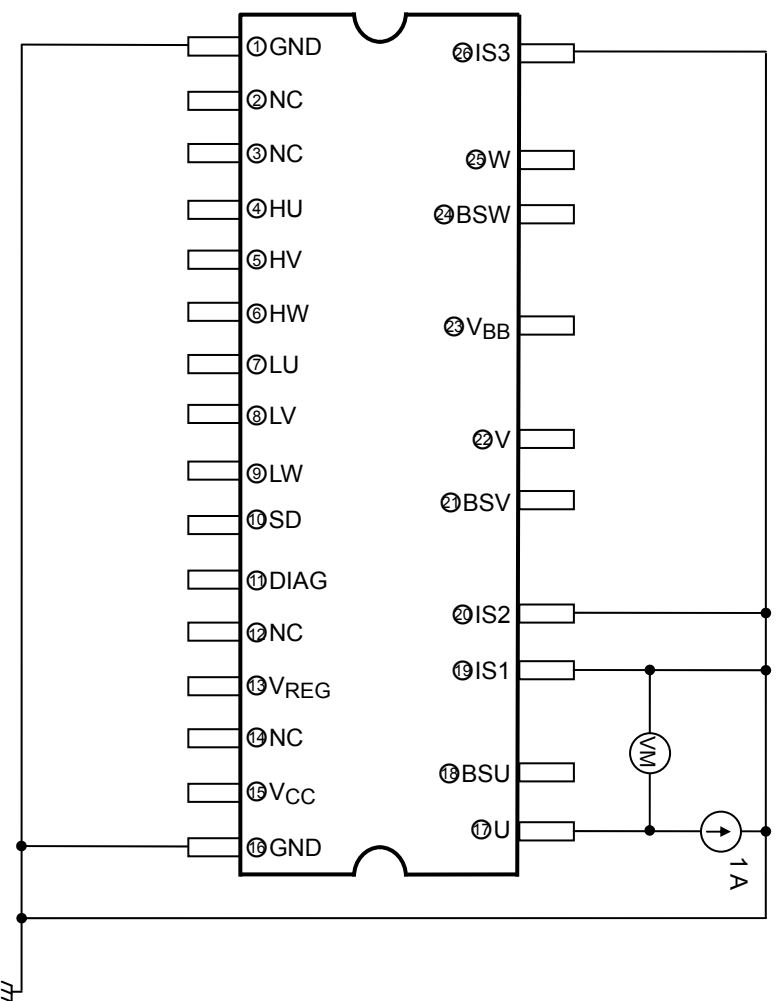

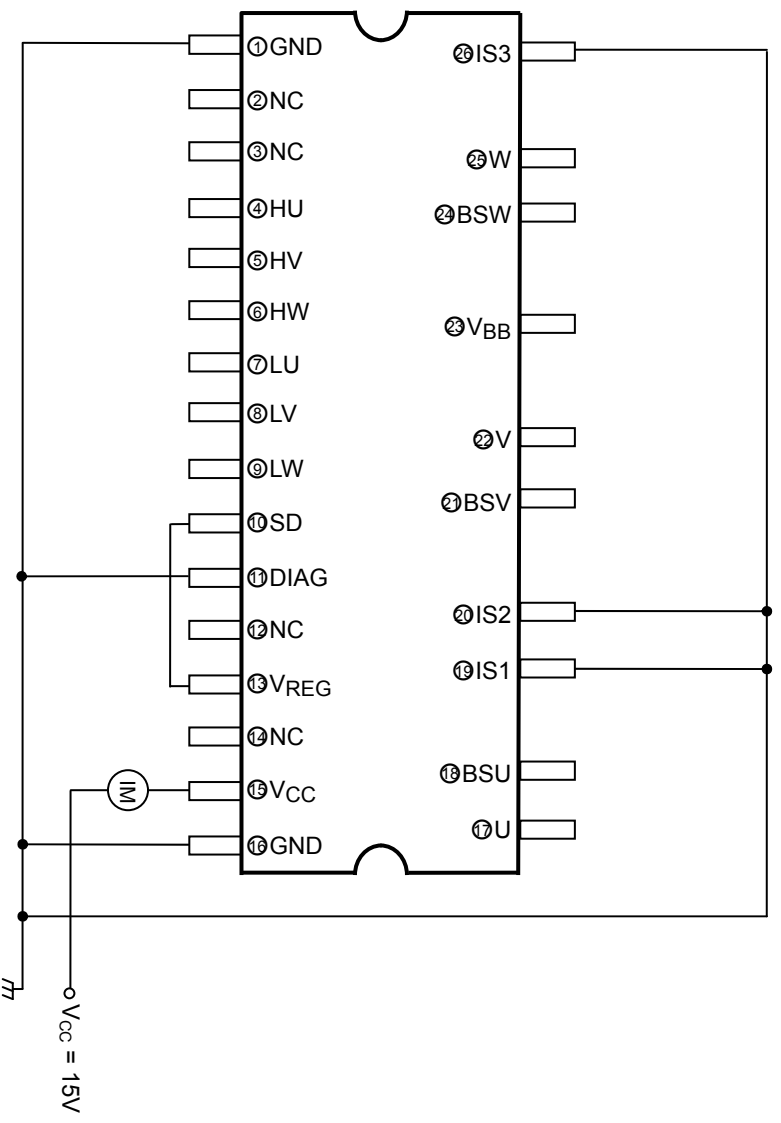
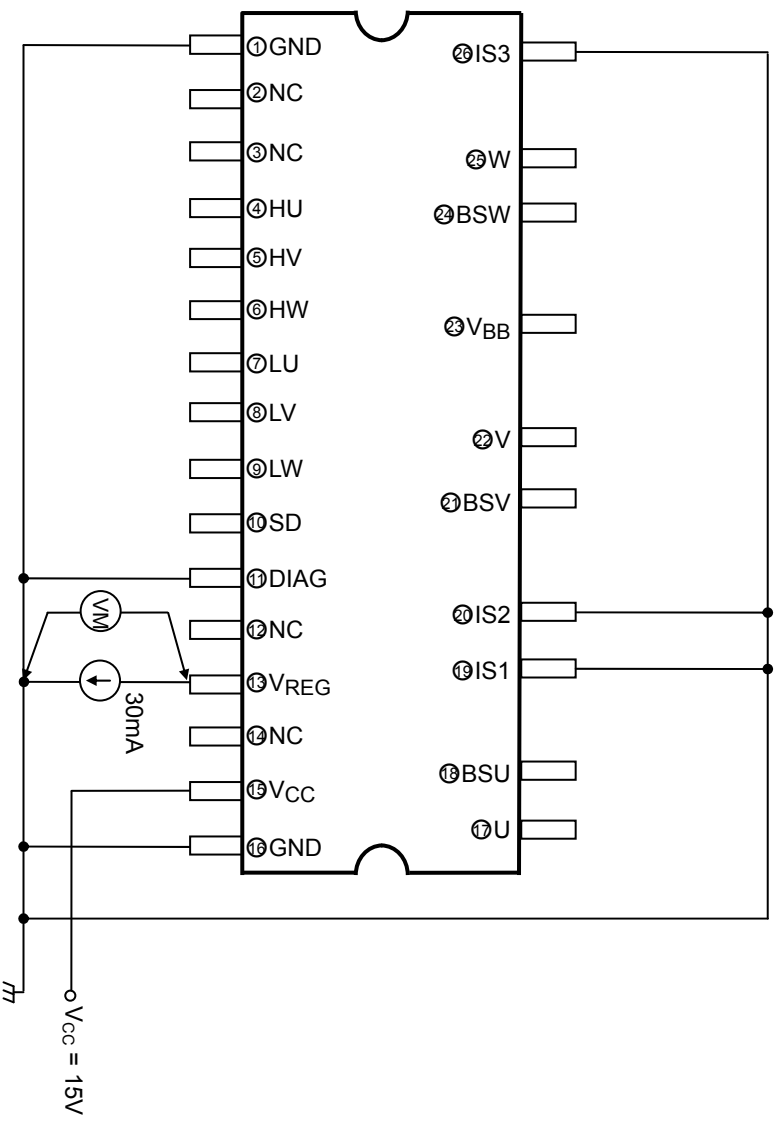
V_{CC} Current Dissipation**Regulator Voltage**

Output ON/OFF Delay Time (U-phase low side)

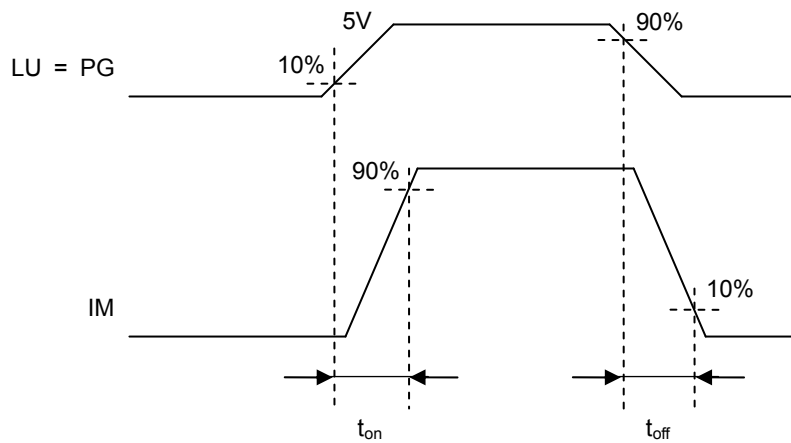
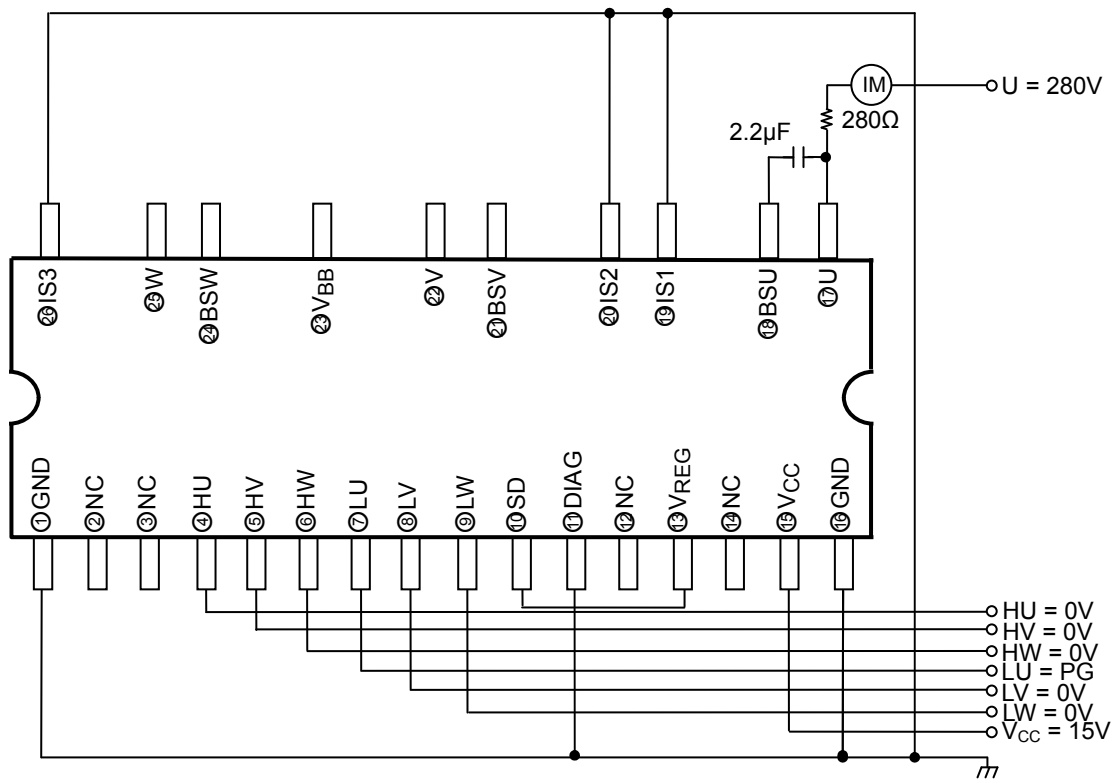

V_{CC} Under-voltage Protection Operating/Recovery Voltage (U-phase low side)

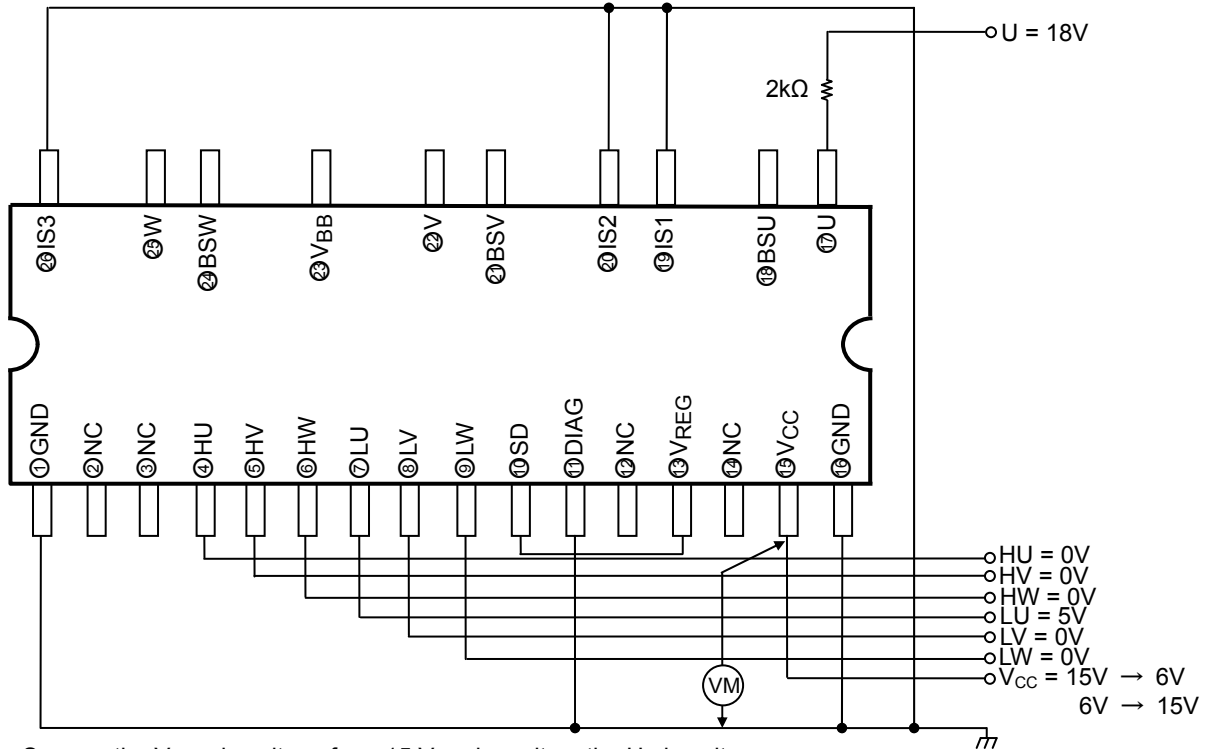

*:Note: Sweeps the V_{CC} pin voltage from 15 V and monitors the U pin voltage.
 The V_{CC} pin voltage when output is off defines the under voltage protection operating voltage.
 Also sweeps from 6 V to increase. The V_{CC} pin voltage when output is on defines the under voltage protection recovery voltage.

V_{BS} Under voltage Protection Operating/Recovery Voltage (U-phase high side)

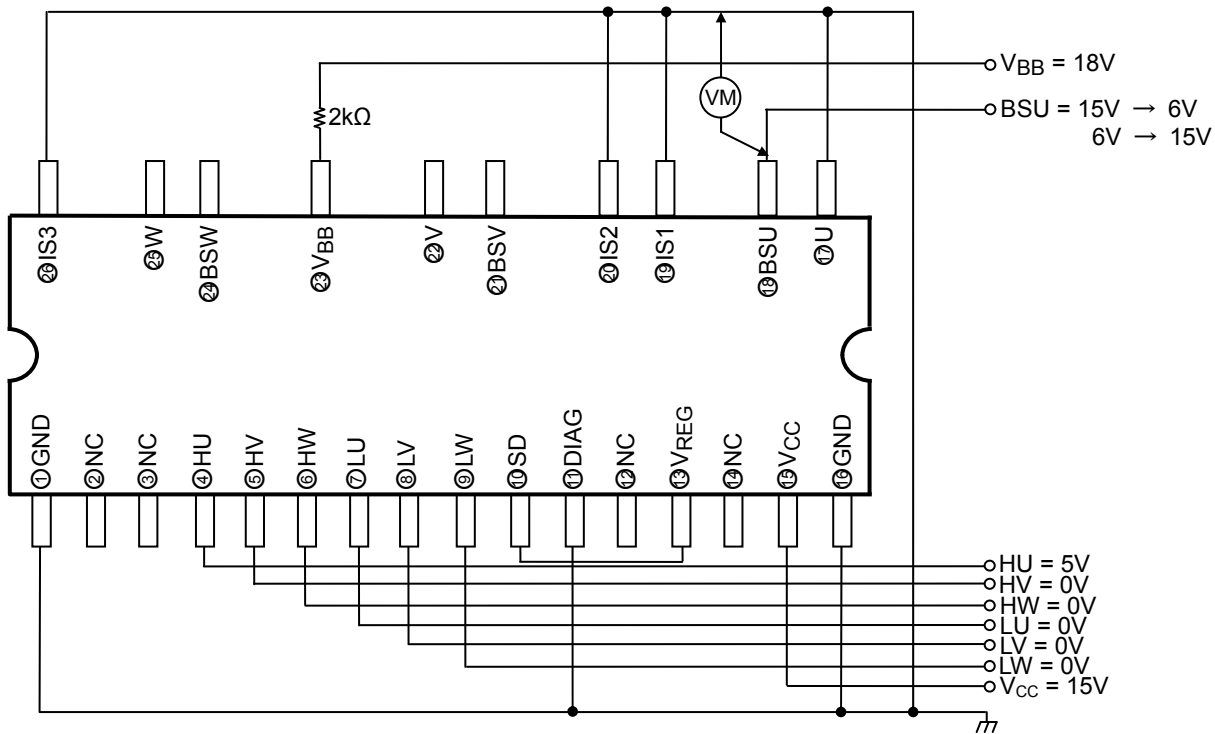

*:Note: Sweeps the BSU pin voltage from 15 V to decrease and monitors the V_{BB} pin voltage. The BSU pin voltage when output is off defines the under voltage protection operating voltage. Also sweeps the BSU pin voltage from 6 V to increase and change the HU pin voltage at 5 V→0 V→5 V each time. It repeats similarly output is on. When the BSU pin voltage when output is on defines the under voltage protection recovery voltage.

Bootstrap Current Dissipation (U-phase high side)

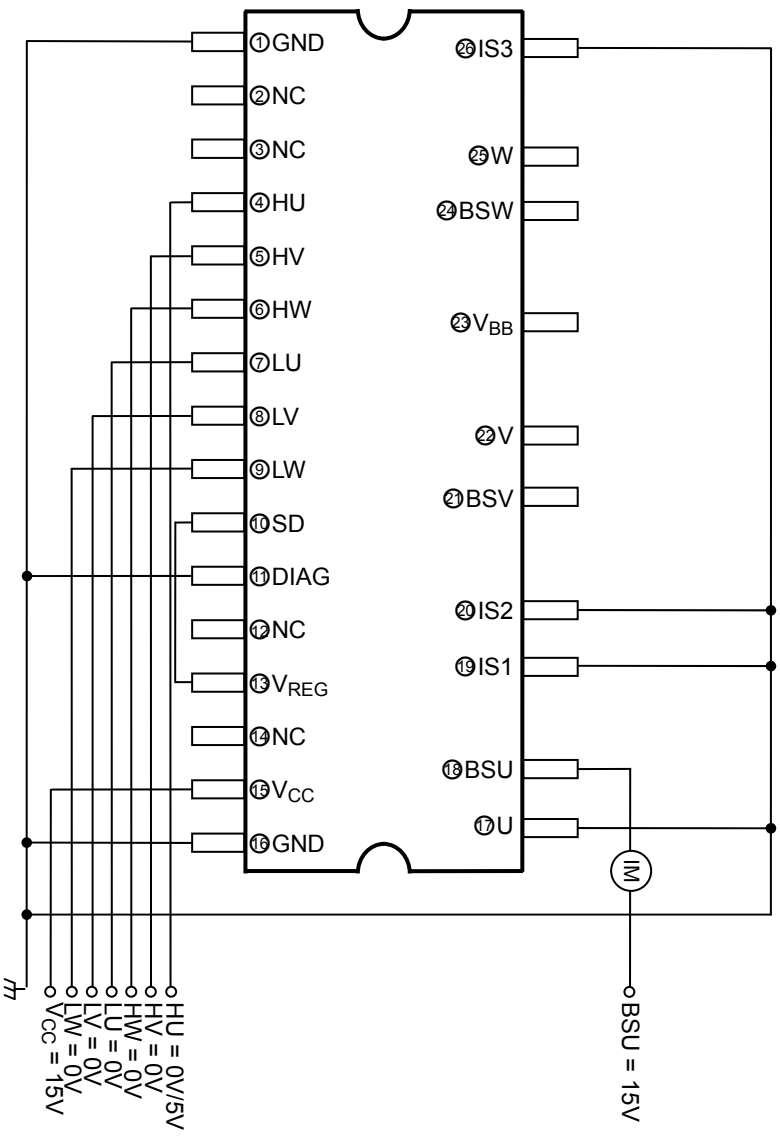

Turn-ON/OFF Loss (low side IGBT + high side FRD)

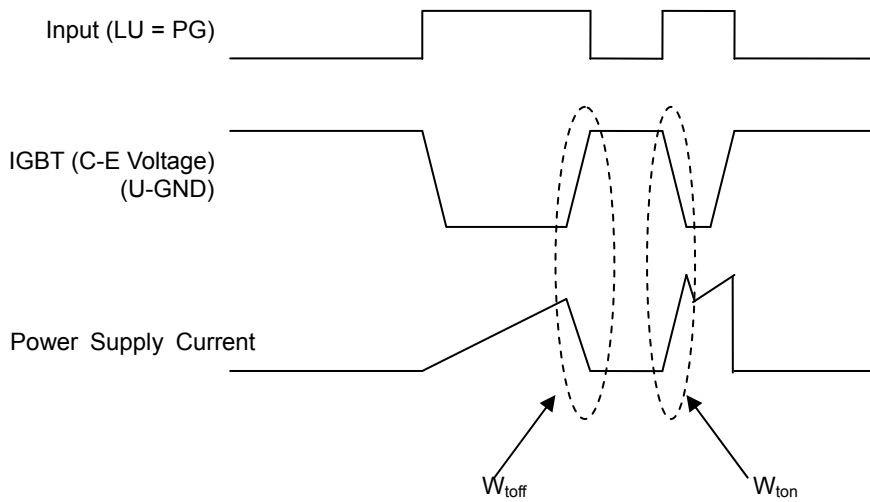
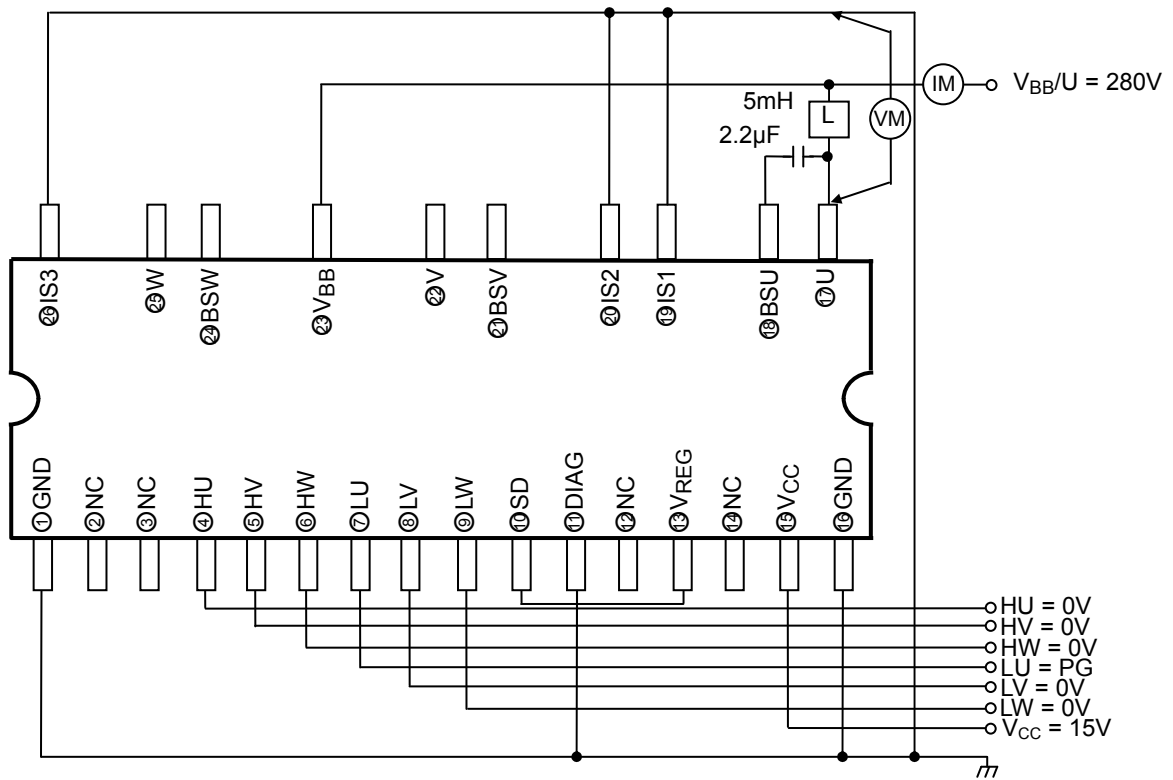

Package Dimensions

HDIP26-P-1332-2.00

Unit : mm

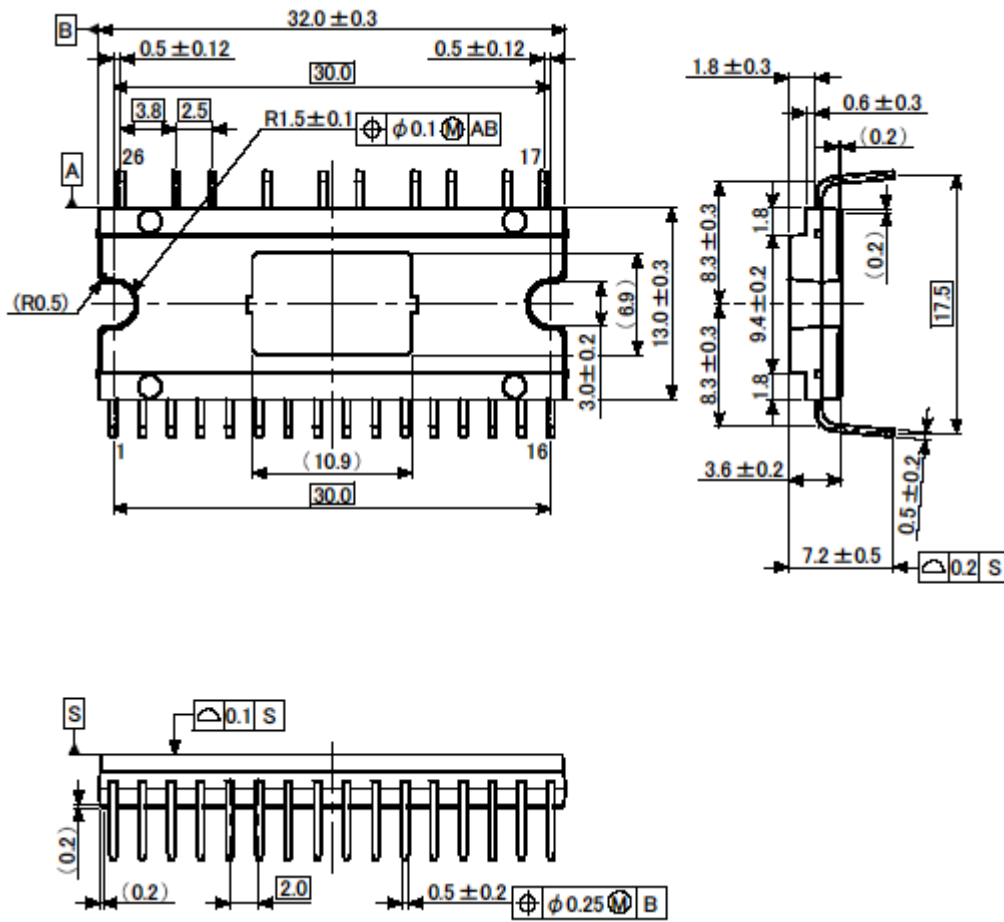

Weight: 3.8 g (typ.)

RESTRICTIONS ON PRODUCT USE

- Toshiba Corporation, and its subsidiaries and affiliates (collectively "TOSHIBA"), reserve the right to make changes to the information in this document, and related hardware, software and systems (collectively "Product") without notice.
- This document and any information herein may not be reproduced without prior written permission from TOSHIBA. Even with TOSHIBA's written permission, reproduction is permissible only if reproduction is without alteration/omission.
- Though TOSHIBA works continually to improve Product's quality and reliability, Product can malfunction or fail. Customers are responsible for complying with safety standards and for providing adequate designs and safeguards for their hardware, software and systems which minimize risk and avoid situations in which a malfunction or failure of Product could cause loss of human life, bodily injury or damage to property, including data loss or corruption. Before customers use the Product, create designs including the Product, or incorporate the Product into their own applications, customers must also refer to and comply with (a) the latest versions of all relevant TOSHIBA information, including without limitation, this document, the specifications, the data sheets and application notes for Product and the precautions and conditions set forth in the "TOSHIBA Semiconductor Reliability Handbook" and (b) the instructions for the application with which the Product will be used with or for. Customers are solely responsible for all aspects of their own product design or applications, including but not limited to (a) determining the appropriateness of the use of this Product in such design or applications; (b) evaluating and determining the applicability of any information contained in this document, or in charts, diagrams, programs, algorithms, sample application circuits, or any other referenced documents; and (c) validating all operating parameters for such designs and applications. **TOSHIBA ASSUMES NO LIABILITY FOR CUSTOMERS' PRODUCT DESIGN OR APPLICATIONS.**
- Product is intended for use in general electronics applications (e.g., computers, personal equipment, office equipment, measuring equipment, industrial robots and home electronics appliances) or for specific applications as expressly stated in this document. Product is neither intended nor warranted for use in equipment or systems that require extraordinarily high levels of quality and/or reliability and/or a malfunction or failure of which may cause loss of human life, bodily injury, serious property damage or serious public impact ("Unintended Use"). Unintended Use includes, without limitation, equipment used in nuclear facilities, equipment used in the aerospace industry, medical equipment, equipment used for automobiles, trains, ships and other transportation, traffic signaling equipment, equipment used to control combustions or explosions, safety devices, elevators and escalators, devices related to electric power, and equipment used in finance-related fields. Do not use Product for Unintended Use unless specifically permitted in this document.
- Do not disassemble, analyze, reverse-engineer, alter, modify, translate or copy Product, whether in whole or in part.
- Product shall not be used for or incorporated into any products or systems whose manufacture, use, or sale is prohibited under any applicable laws or regulations.
- The information contained herein is presented only as guidance for Product use. No responsibility is assumed by TOSHIBA for any infringement of patents or any other intellectual property rights of third parties that may result from the use of Product. No license to any intellectual property right is granted by this document, whether express or implied, by estoppel or otherwise.
- **ABSENT A WRITTEN SIGNED AGREEMENT, EXCEPT AS PROVIDED IN THE RELEVANT TERMS AND CONDITIONS OF SALE FOR PRODUCT, AND TO THE MAXIMUM EXTENT ALLOWABLE BY LAW, TOSHIBA (1) ASSUMES NO LIABILITY WHATSOEVER, INCLUDING WITHOUT LIMITATION, INDIRECT, CONSEQUENTIAL, SPECIAL, OR INCIDENTAL DAMAGES OR LOSS, INCLUDING WITHOUT LIMITATION, LOSS OF PROFITS, LOSS OF OPPORTUNITIES, BUSINESS INTERRUPTION AND LOSS OF DATA, AND (2) DISCLAIMS ANY AND ALL EXPRESS OR IMPLIED WARRANTIES AND CONDITIONS RELATED TO SALE, USE OF PRODUCT, OR INFORMATION, INCLUDING WARRANTIES OR CONDITIONS OF MERCHANTABILITY, FITNESS FOR A PARTICULAR PURPOSE, ACCURACY OF INFORMATION, OR NONINFRINGEMENT.**
- Do not use or otherwise make available Product or related software or technology for any military purposes, including without limitation, for the design, development, use, stockpiling or manufacturing of nuclear, chemical, or biological weapons or missile technology products (mass destruction weapons). Product and related software and technology may be controlled under the Japanese Foreign Exchange and Foreign Trade Law and the U.S. Export Administration Regulations. Export and re-export of Product or related software or technology are strictly prohibited except in compliance with all applicable export laws and regulations.
- Please contact your TOSHIBA sales representative for details as to environmental matters such as the RoHS compatibility of Product. Please use Product in compliance with all applicable laws and regulations that regulate the inclusion or use of controlled substances, including without limitation, the EU RoHS Directive. TOSHIBA assumes no liability for damages or losses occurring as a result of noncompliance with applicable laws and regulations.