

## General Description

The AAT1290 is a high-efficiency, high-current boost converter capable of 1.5A typical output current. It is an ideal power solution for LED photo flash applications in all single cell Li-ion powered products.

The AAT1290 maintains output current regulation by switching the internal high-side and low-side switch transistors. The transistor switches are pulse-width modulated at a fixed frequency of 2MHz. The high switching frequency allows the use of a small inductor and output capacitor, making the AAT1290 ideally suited for small battery-powered applications.

AnalogicTech's proprietary AS<sup>2</sup>Cwire<sup>™</sup> (Advanced Simple Serial Control<sup>™</sup>) serial digital interface is used to enable, disable, configure, and program the operation of the AAT1290. Using the AS<sup>2</sup>Cwire interface, the movie-mode current level for the LED, the safety timer delay, and the flash-to-movie-mode current ratio can be programmed to one of 16 levels. In addition, the single-wire serial protocol sets output channel control. The AAT1290 also includes a separate Flash Enable input to initiate both the flash operation and the default timer which can be used either to terminate a flash event at the end of a user-programmed delay or as a safety feature. Also included is a Flash Inhibit pin which reduces the flash current to movie-mode levels during high battery demand.

The maximum flash and movie-mode current is set by one external resistor where the ratio of Flash to Movie-mode current is set at approximately 7.3:1. The AAT1290 can drive one high current LED.

The AAT1290 contains a thermal management system to protect the device in the event of an output short-circuit condition. Built-in circuitry prevents excessive inrush current during start-up. The shutdown feature reduces quiescent current to less than 1.0 $\mu$ A.

The AAT1290 is available in a Pb-free, thermally-enhanced 14-pin 3x3mm TDFN package.

## Features

- V<sub>IN</sub> Range: 2.7V to 5.5V
- Single Channel Flash Output
- Up to 1.5A Regulated Output Current
- Up to 85% Efficiency with Small Inductor (1 $\mu$ H)
- 2 MHz Switching Frequency
- Separate Flash Enable
- User-Programmable Safety Timer
- Single Resistor Sets Flash and Movie Mode Current
- AS<sup>2</sup>Cwire Single Wire Programming:
  - Movie Mode Current
  - Movie Mode Enable
  - Flash/Movie Mode Current Ratio
  - Flash Safety Timer
- True Load Disconnect
- Soft-Start and Input Current Limit
- Over-Voltage (Open LED, Open Circuit), Short Circuit, and Over-Temperature Protection
- Shutdown Current < 1.0 $\mu$ A
- 14-pin TDFN 3x3 mm Package
- -40°C to +85°C Temperature Range

## Applications

- Camera Enabled Mobile devices
- Cellphones/Smartphones
- Digital Still Cameras (DSCs)
- LED Photo Flash/Torch
- Multimedia Mobile Phone

## Typical Application

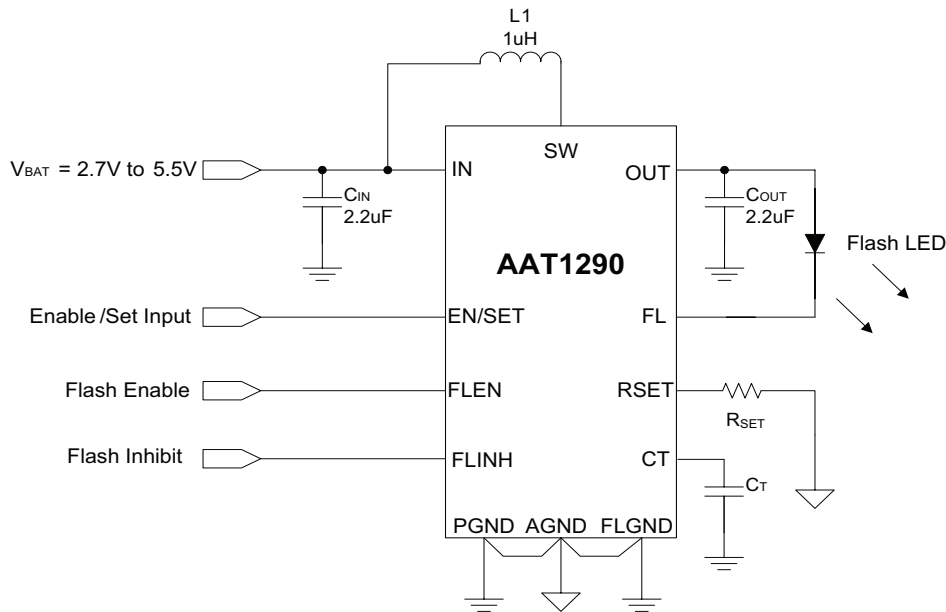

## Pin Descriptions

Pin #	Symbol	Function
1	CT	Flash timer control input. Connect a capacitor between CT and AGND to set maximum duration of the flash pulse. To disable the flash timer, connect CT to AGND.
2	EN/SET	Enable and Serial Control input. EN/SET is the AS <sup>2</sup> Cwire addressing and programming input to: a) adjust the movie-mode current level; b) program the flash timer based on CT; c) select the Flash-to-Movie-mode ratio; and d) enable/disable movie mode operation.
3	FLEN	Flash enable pin. A low-to-high transition on the FLEN pin initiates a flash pulse and a high-to-low transition on the FLEN pin terminates a flash pulse.
4, 9	AGND	Analog ground pin. Connect AGND to PGND and FLGND at a single point as close to the AAT1290 as possible.
5	IN	Flash output boost converter power input. Connect IN to the input power source. Connect a 2.2µF or larger ceramic capacitor from IN to PGND and locate as close as possible to the IC package for optimum performance.
6	SW	Boost converter switching node. Connect a 1µH inductor between SW and IN.
7	PGND	Power ground. Connect PGND to the same single point as AGND located as close to the IC as possible.
8	OUT	Power output of the boost converter. Connect a 2.2µF or larger ceramic capacitor from OUT to PGND as close as possible to the AAT1290. Connect OUT to the anode of the Flash LED.
10	FLINH	Flash inhibit pin. FLINH is an active HIGH control input with an internal 200kΩ resistor to AGND. A low-to-high transition on the FLINH pin reduces FL sink current to the maximum (default) movie-mode current level for the duration of FLINH. Strobing the FLINH pin low to high does not reset the flash timer.
11	NC	No connect.
12	FLGND	Flash ground pin. Connect FLGND to PGND and AGND at a single point as close to the AAT1290 as possible.
13	FL	LED Flash current sink pin. Connect the cathode of Flash LED to FL.
14	RSET	Flash current setting input. Connect a resistor from RSET to AGND to program the desired flash current for the current sink FL.
EP		Exposed paddle (bottom); Connect EP to PGND as close as possible to the AAT1290.

## Pin Configuration

### TDFN33-14 (Top View)

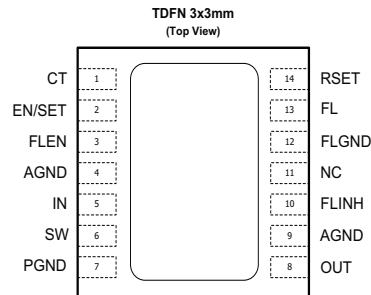

## Absolute Maximum Ratings<sup>1</sup>

Symbol	Description	Value	Units
IN, SW, OUT	Maximum Rating	-0.3 to 6.0	
RSET, EN/SET, FLEN, FLINH, CT, FL	Maximum Rating	$V_{IN} + 0.3$	
$T_J$	Operating Temperature Range	-40 to 150	°C
$T_s$	Storage Temperature Range	-65 to 150	
$T_{LEAD}$	Maximum Soldering Temperature (at leads, 10 sec)	300	

## Recommended Operating Conditions

Symbol	Description	Value	Units
$\theta_{JA}$	Thermal Resistance	50	°C/W
$P_D$	Maximum Power Dissipation	2	W

1. Stresses above those listed in Absolute Maximum Ratings may cause permanent damage to the device. Functional operation at conditions other than the operating conditions specified is not implied. The AAT1290 is guaranteed to meet performance specifications over the -40°C to +85°C operating temperature range and is assured by design, characterization, and correlation with statistical process controls.

**Electrical Characteristics<sup>1</sup>**

$V_{IN} = 3.6V$ ;  $C_{IN} = 2.2\mu F$ ;  $C_{OUT} = 2.2\mu F$ ;  $L = 1\mu H$ ;  $R_{SET} = 107k\Omega$ ;  $T_A = -40^\circ C$  to  $85^\circ C$ , unless otherwise noted. Typical values are  $T_A = 25^\circ C$ .

Symbol	Description	Conditions	Min	Typ	Max	Units
<b>Power Supply</b>						
$V_{IN}$	Input Voltage Range		2.7		5.5	V
$V_{OUT(MAX)}$	Maximum Output Voltage				5.5	
$I_{IN(Q)}$	Supply Current	EN/SET = FLEN = IN, $I_{FL} = 1.5A$		1.4		mA
		EN/SET = IN, FLEN = AGND		0.23		
$I_{SHDN(MAX)}$	$V_{IN}$ Shutdown Current	EN/SET = FLEN = FLINH = AGND			1	$\mu A$
$I_{FL}$	Output Current, Flash Mode	$R_{SET} = 107k\Omega$	1.2	1.5		A
$I_{MM(LOAD)}$	Output Current, Movie Mode	$R_{SET} = 107k\Omega$ , Movie Mode Current Set = 100%		206		mA
$I_{FL(ACC)}$	Flash Current Accuracy	$I_{FL} = 1.2A$	-10		10	%
$f_{OSC}$	Switching Frequency	$T_A = 25^\circ C$	1.5	2.0	2.5	MHz
$t_{DEFAULT}$	Default Flash Timer ON Time	$C_T = 68nF$		600		ms
$T_{SD}$	Thermal Shutdown Threshold			140		$^\circ C$
$T_{SD(HYS)}$	Thermal Shutdown Hysteresis			15		$^\circ C$
<b>EN/SET/ FLEN/ FLINH Logic Control</b>						
$V_{EN/SET(L)}$ , $V_{FLEN(L)}$	EN/SET, FLEN Input Low Threshold				0.4	V
$V_{EN/SET(H)}$ , $V_{FLEN(H)}$	EN/SET, FLEN Input High Threshold		1.4			
$I_{EN/SET}$ , $I_{FLEN}$	EN/SET or FLEN Input Leakage Current	$V_{EN/SET}, V_{FLEN} = V_{IN}$	-1		1	$\mu A$
$V_{T(FLINH)}$	FLINH Input Threshold Voltage			$\frac{1}{2}V_{IN}$		V
$R_{IN(FLINH)}$	FLINH Input Resistance to AGND			200		k $\Omega$
$t_{EN/SET(LOW)}$	EN/SET Serial Interface Low Time		0.3		75	$\mu s$
$t_{EN/SET(HI\_MIN)}$	Minimum EN/SET High Time			50		ns
$t_{EN/SET(HI\_MAX)}$	Maximum EN/SET High Time				75	$\mu s$
$t_{EN/SET(OFF)}$	EN/SET Off Timeout				500	
$t_{EN/SET(LAT)}$	EN/SET Latch Timeout				500	
$t_{FLEN\_ON}$	FLEN ON Delay Time	EN/SET = AGND		25		
$t_{FLEN\_OFF}$	FLEN OFF Delay Time	EN/SET = AGND		10		
$t_{FLINH\_ON}$	FLINH ON Delay Time			15		

1. The AAT1290 is guaranteed to meet performance specifications over the  $-40^\circ C$  to  $+85^\circ C$  operating temperature range and is assured by design, characterization, and correlation with statistical process controls.

**Typical Characteristics**

**Movie Mode Efficiency vs Input Voltage**

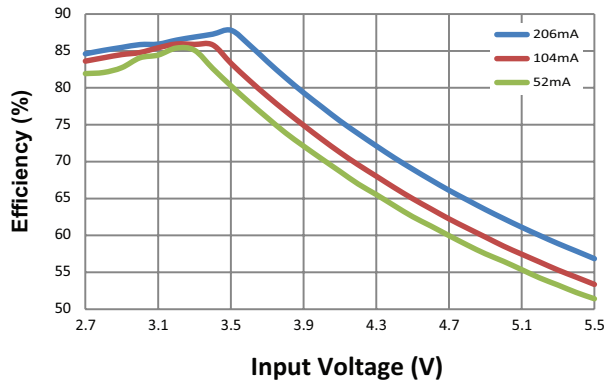

**Flash Mode Efficiency vs Input Current**

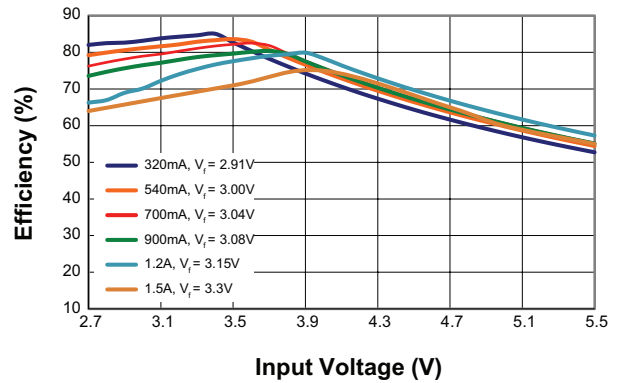

**Flash Mode Current Accuracy vs Temperature**  
(I<sub>FL</sub> = 1.5A; V<sub>IN</sub> = 3.6V; L = 1μH)

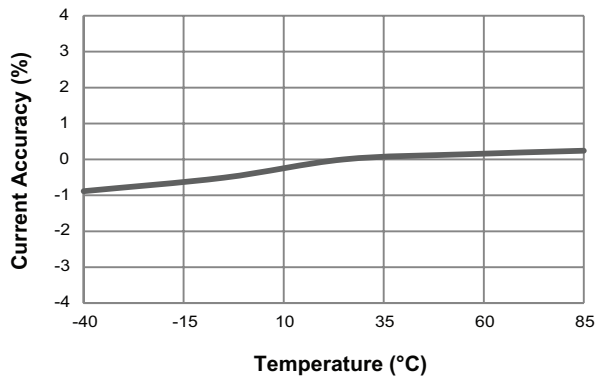

**Movie Mode Current Accuracy vs Temperature**  
(I<sub>FL</sub> = 206mA; V<sub>IN</sub> = 3.6V; L = 1μH)

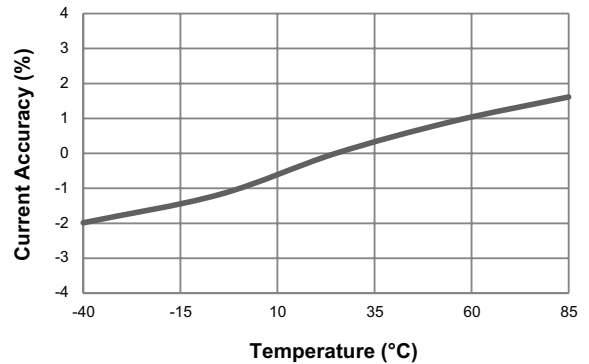

**Movie Mode Current Accuracy vs. Input Voltage**  
(I<sub>FL</sub> = 206mA; L = 1μH)

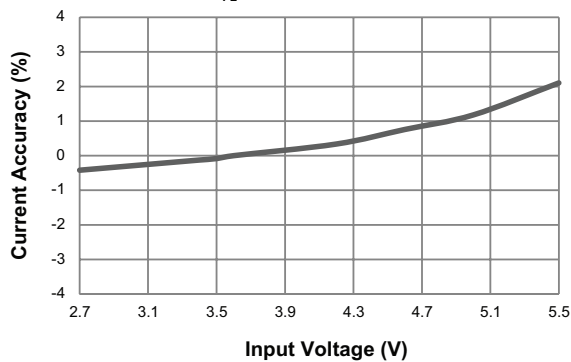

**Flash On Time Delay vs Input Voltage**  
(I<sub>FL</sub> = 1.5A; C<sub>OUT</sub> = 2.2μF; L = 1μH)

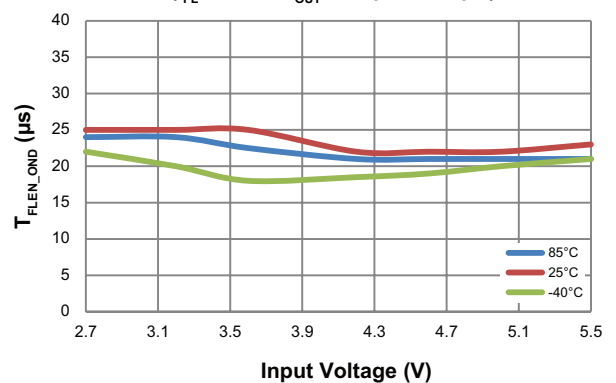

**Typical Characteristics**

**Flash Timeout vs Temperature**  
( $I_{FL} = 1.5A$ ;  $V_{IN} = 3.6V$ ;  $C_T = 68nF$ )

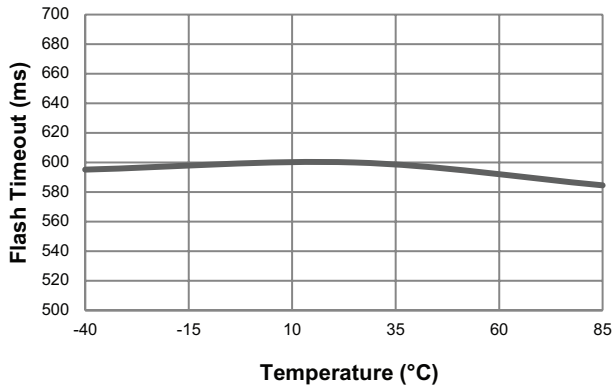

**Flash Timeout Delay vs  $C_T$  Capacitor**  
( $I_{FL} = 1.5A$ ;  $V_{IN} = 3.6V$ )

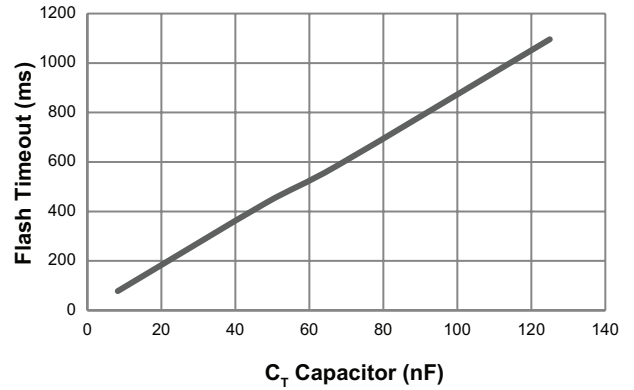

**EN/SET Off Timeout vs Input Voltage**

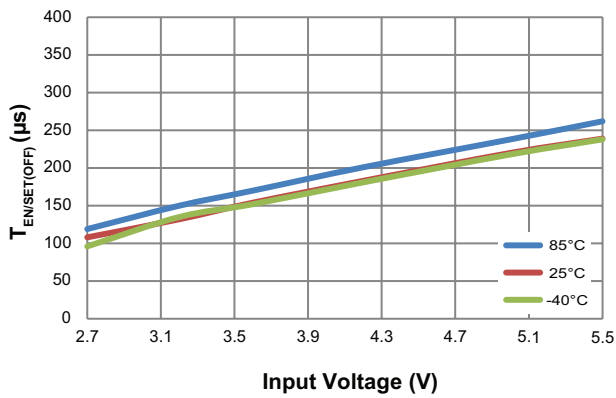

**EN/SET Latch Timeout vs Input Voltage**

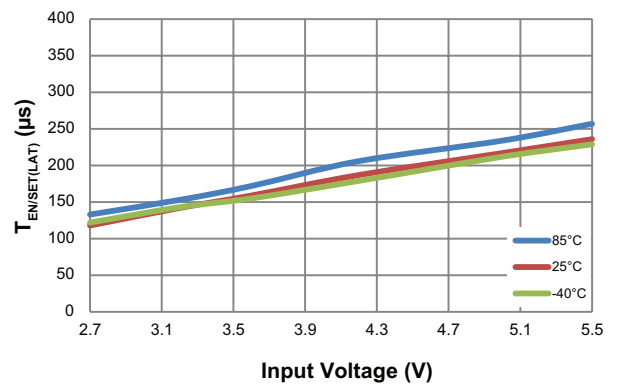

**EN/SET, FLEN High Threshold Voltage vs Input Voltage**

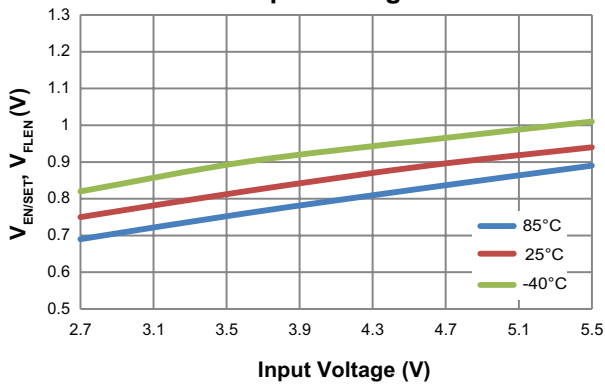

**EN/SET, FLEN Low Threshold Voltage vs Input Voltage**

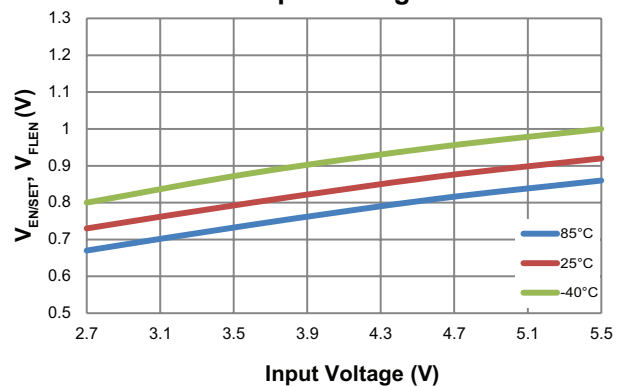

### Typical Characteristics

**Boost Switching Frequency vs Input Voltage**  
( $T_A = 25^\circ\text{C}$ ;  $L = 1\mu\text{H}$ )

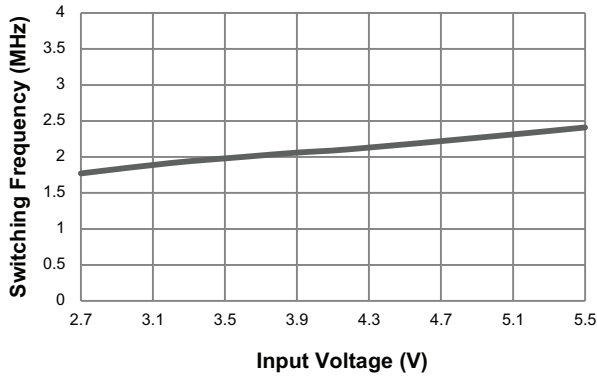

**Supply Current vs Input Voltage**  
( $V_{\text{EN/SET}} = V_{\text{FLEN}} = V_{\text{IN}}$ ;  $I_{\text{FL}} = 0\text{mA}$ ; Non-Switching)

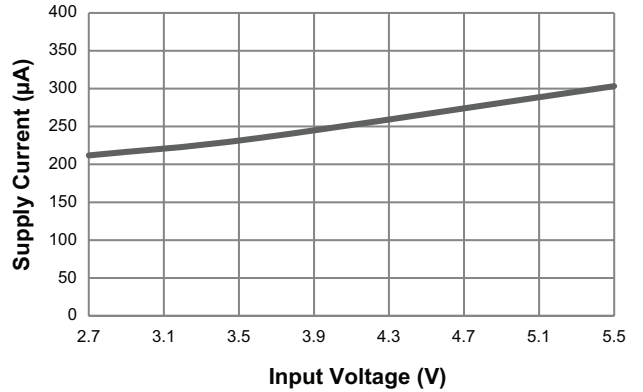

**Movie Mode Ripple**  
( $I_{\text{FL}} = 206\text{mA}$ ;  $C_{\text{OUT}} = 2.2\mu\text{F}$ ;  $V_{\text{IN}} = 3.3\text{V}$ ;  $L = 1\mu\text{H}$ )

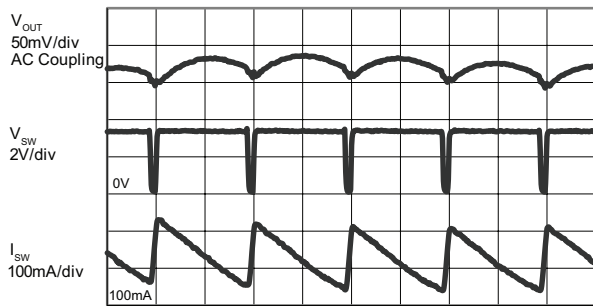

Time (500ns/div)

**Flash Mode Ripple**  
( $I_{\text{FL}} = 1.5\text{A}$ ;  $C_{\text{OUT}} = 2.2\mu\text{F}$ ;  $V_{\text{IN}} = 3.6\text{V}$ ;  $L = 1\mu\text{H}$ )

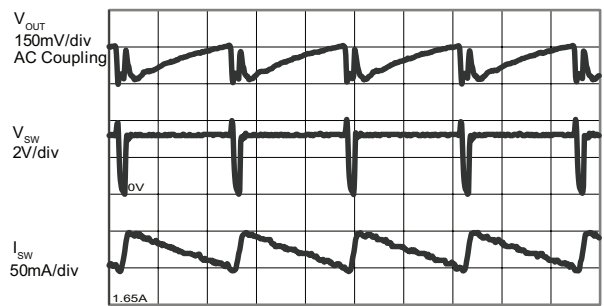

Time (200ns/div)

**Flash Turn On Characteristic**  
( $I_{\text{FL}} = 1.5\text{A}$ ;  $C_{\text{OUT}} = 2.2\mu\text{F}$ ;  $V_{\text{IN}} = 3.6\text{V}$ ;  $L = 1\mu\text{H}$ )

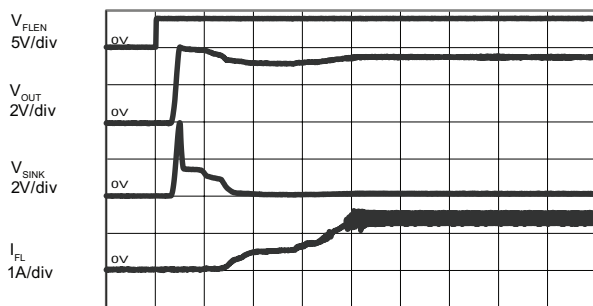

Time (50ns/div)

**Movie Mode to Flash Turn On Characteristic**  
( $I_{\text{FL}} = 206\text{mA}$  to  $1.5\text{A}$ ;  $C_{\text{OUT}} = 2.2\mu\text{F}$ ;  $V_{\text{IN}} = 3.6\text{V}$ ;  $L = 1\mu\text{H}$ )

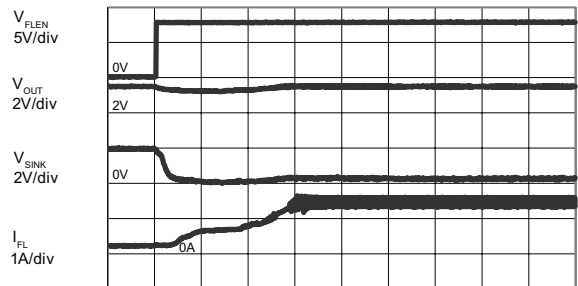

Time (50ns/div)

### Typical Characteristics

#### Movie Mode Turn On Characteristic

( $I_{FL} = 206\text{mA}$ ;  $C_{OUT} = 2.2\mu\text{F}$ ,  $V_{IN} = 3.6\text{V}$ ,  $L = 1\mu\text{H}$ )

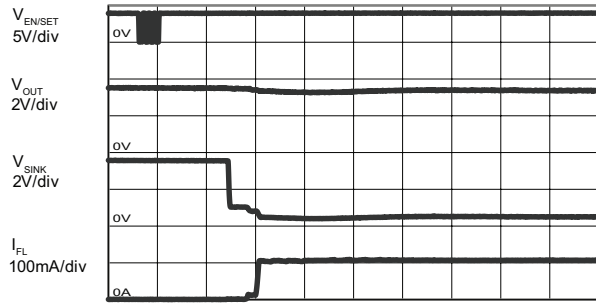

Time (100µs/div)

#### Movie Mode Transition Characteristic

( $I_{FL} = 206\text{mA}$  to  $376\text{mA/ch}$ ;  $C_{OUT} = 2.2\mu\text{F}$ ,  $V_{IN} = 3.6\text{V}$ ,  $L = 1\mu\text{H}$ )

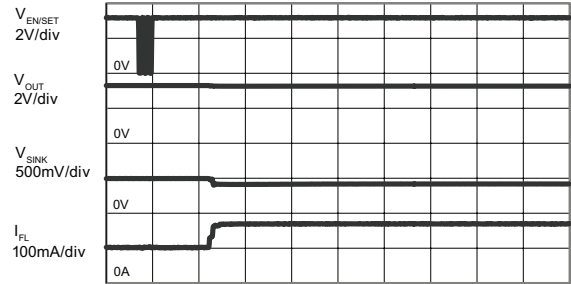

Time (100µs/div)

## Functional Block Diagram

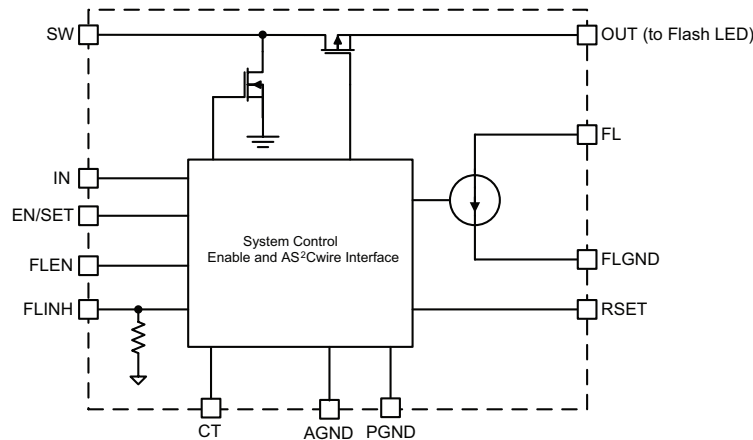

## Functional Description

The AAT1290 is a boost converter with a current regulated output designed to drive high current white LEDs used in camera flash applications. The AAT1290 has a constant current sink channel to accurately regulate the current flow through a high current, high intensity white Flash LED. There are two basic modes of operation in the AAT1290; a Flash mode controlled by the FLEN pin and the movie mode controlled through the AS<sup>2</sup>Cwire interface.

### Flash Mode

A flash pulse is initiated by strobing the FLEN input pin low-to-high. This also starts an internal flash timer. The maximum flash current in the AAT1290 is set by an external resistor,  $R_{SET}$ , which programs the maximum flash current and the maximum movie-mode current. The AAT1290's flash timer will terminate the flash current regardless of the status of the FLEN pin. This can be used either for a simple flash pulse timing or a safety timer in the event of a control logic malfunction to prevent the LED from over-heating. The maximum flash time is determined by an external timing capacitor connected to the CT pin. The flash duration can be set from 50ms up to a maximum of 1s. The AS<sup>2</sup>Cwire interface allows flexible adjustment of the flash timer duration. This allows the flash timer duration to be reduced in 16 linear steps from the maximum time set by the timing capacitor. If the safety timer is not needed in the application, it can be disabled by connecting the CT pin directly to AGND.

In mobile GSM systems where the phone remains in

constant contact with the base station by regular communication, a FLINH pin is provided to prevent both the camera flash and PA transmission pulses from occurring simultaneously. This avoids potential dips to the Li-ion battery voltage below the system's undervoltage lockout threshold (UVLO). During a flash event, strobing the FLINH pin low-to-high reduces the LED current to the default movie-mode current level for the duration of FLINH. Strobing FLINH high-to-low instructs the AAT1290 to revert to the maximum flash LED current level, assuming that the FLEN pin is still active (HIGH) and the flash timer has not expired.

### Movie Mode

The movie / torch mode current level, and the flash to maximum movie mode current ratio are programmed by the AAT1290 AS<sup>2</sup>Cwire interface. The movie-mode current level can be adjusted to one of 16 steps using a logarithmic scale where each code level is 1dB below the previous code. The maximum movie to flash mode current ratio can be set from 1:2 to OFF with respect to the maximum programmed flash current as set by the  $R_{SET}$  resistor. The manual FLEN signal has priority over movie-mode operation.

Movie mode operation is controlled entirely by the AS<sup>2</sup>Cwire interface via the EN/SET pin. The FLEN signal will override movie-mode AAT1290 operation when toggled to a logic high level. The part will not reenter movie mode when FLEN is brought low. To reenter movie mode after a flash event the part must be cycled off and back on to reset the movie mode and reprogrammed via the AS<sup>2</sup>Cwire interface to the desired movie mode operation.

### Over-Temperature Protection

The AAT1290 has internal thermal protection circuitry to disable the device if the power dissipation exceeds a preset thermal limit. The junction over-temperature threshold is 140°C with 15°C of temperature hysteresis. During Flash or movie-mode operation, should an environmental condition, flash current sink or the boost converter cause the internal die temperature to rise above 140°C, the boost converter will be shut down. The boost converter output operation will automatically recover when the over-temperature fault condition is removed.

### Over-Voltage Protection (Open LED, Open Circuit)

The AAT1290's output voltage is limited by internal over-voltage protection circuitry, which prevents damage to the AAT1290 from open LED or open circuit conditions. During an open circuit event, the boost converter output

will rise to the over-voltage protection (OVP) threshold at 5.5V (typical). Upon sensing the OVP event, the boost converter will be disabled to prevent damage to the device. Once the open circuit fault condition is removed, boost converter switching will resume.

### Short Circuit Protection

The AAT1290 is equipped with an auto-disable feature for the flash LED current sink. After the IC is enabled and system start up commences, a test current of 2-3mA (typical) is forced through the current sink. The current sink will be disabled if the voltage of the SINK pin does not drop to a predetermined threshold. This feature is very convenient for disabling the current sink in the event of the flash LED short-circuit failure. This small test current is added to the set output current in both Flash and movie mode conditions.

### Timing Diagram

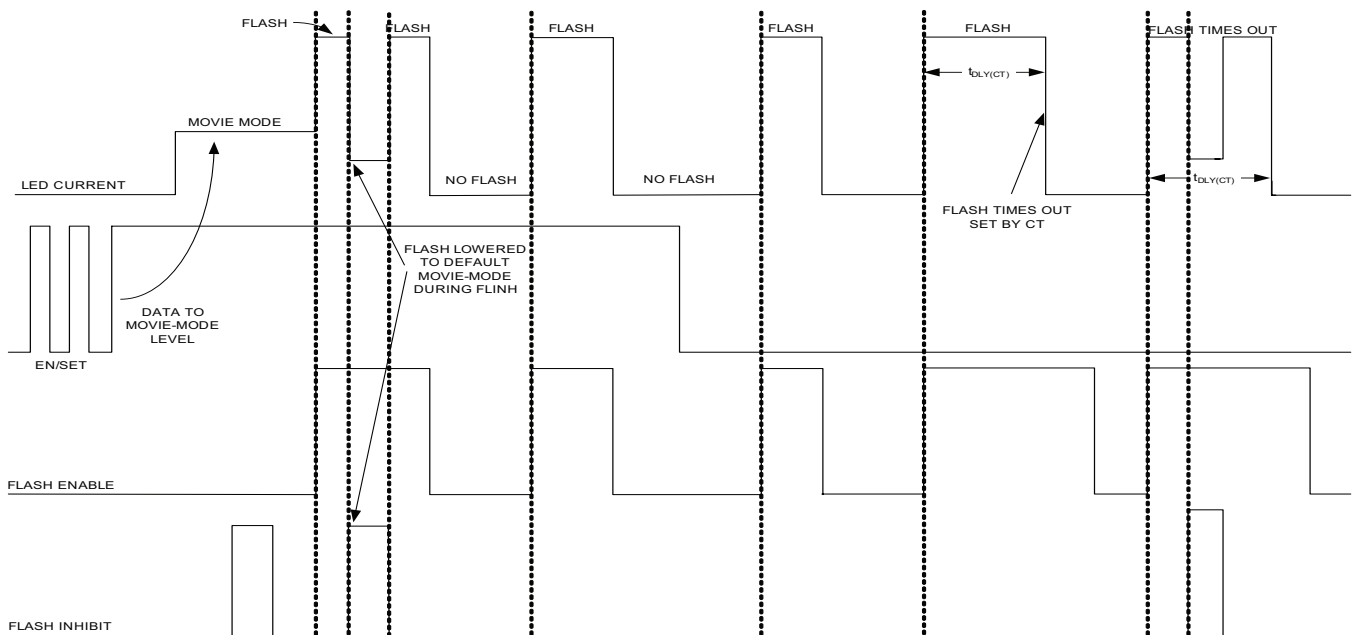

No AS<sup>2</sup>C address programming shown.

## Applications Information

### Flash Mode LED Current

The flash sink current can be programmed up to a maximum flash current level of 1.5A.

The maximum flash current is set by the  $R_{SET}$  resistor. For the desired flash current in output, the resistor value can be calculated using the following equation:

$$R_{SET} = \frac{1A}{I_{FL(MAX)}} \cdot 162k\Omega$$

A flash event is initiated by asserting the FLEN pin. A flash event is automatically terminated when FLEN is de-asserted or if the safety timer terminates before the FLEN pin is de-asserted. Any time that the FLINH pin is asserted, the default movie-mode current level will appear at FL. The default movie-mode current level will be maintained on FL as long as the FLINH and FLEN pins are asserted, and the safety timer continues to run.

### AS<sup>2</sup>Cwire Control of Movie Mode Operation and Flash Safety Timer

In the AAT1290, control of the movie mode operation and flash timer is managed by the Advanced Simple Serial Control (AS<sup>2</sup>Cwire) interface. AS<sup>2</sup>Cwire relies on the number of rising edges of the EN/SET pin to address and load the AAT1290's registers. As shown in Table 1, Address 0 controls the Movie Current level as a percent-

age of the maximum movie mode current level. Address 1 controls the safety timer duration as a percentage of the maximum value set by an external timing capacitor. Address 2 enables the LED channel during movie mode. Finally, Address 3 sets the maximum possible current for movie mode operation. The maximum movie mode current is set as a fraction of the flash current with a peak value of 1/2 and a default value of 1/7.3. The last column in Table 1 shows the default values for each of the address registers.

### AS<sup>2</sup>Cwire Serial Interface

AS<sup>2</sup>Cwire latches data or address after the EN/SET pin has been held high for longer than  $t_{LAT}$  (500 $\mu$ s). Address or data is differentiated by the number of EN/SET rising edges. Since the data registers are 4 bits each, the differentiating number of pulses is 2<sup>4</sup> or 16, so that Address 0 is signified by 17 rising edges, Address 1 by 18 rising edges and Address 2 by 19 rising edges and Address 3 by 20 rising edges. Data is applied to any number of rising edges between 1 and 16, inclusive. A typical write protocol is a burst of EN/SET rising edges, signifying a particular address, followed by a pause with EN/SET held high for the prescribed  $t_{LAT}$  timeout period, a burst of rising edges signifying data, and a  $t_{LAT}$  timeout for the data registers. Once an address is set, then multiple writes to the corresponding data register are allowed. Address 0 is the default address on the first rising edge after the AAT1290 has been disabled.

Address	EN/SET Rising Edges	Function	Default (No programming)
0	17	Movie Mode Current	100%
1	18	Flash Safety Timer	16/16
2	19	Movie Mode Output Configuration	OFF
3	20	Flash/Movie Mode Current Ratio	1/7.3

**Table 1: AS<sup>2</sup>Cwire Serial Interface Addressing.**

When EN/SET is strobed low and held low longer than  $t_{OFF}$  (500µs), the AAT1290 enters shutdown mode and draws less than 1µA from  $V_{IN}$ . All data and address are cleared (reset to 0) during shutdown.

The AS<sup>2</sup>Cwire addressing allows the control of the movie-mode output current, the safety timer delay, the FL current sink, and the ratio of movie-mode current to flash current.

If there are no programmed write instructions applied to the EN/SET pin prior to the assertion of the FLEN pin and the device is enabled, then all registers will be loaded with their default values shown in Table 1. In the event that the number of rising edges applied at the EN/SET pin is less than 17, the AAT1290's state machine will interpret instruction to program the output currents to the desired current level for movie-mode operation.

### Movie Mode Current – Address 0

The AAT1290 movie mode current settings are controlled using the AS<sup>2</sup>Cwire interface. Movie Mode current has a maximum value of 50% of the flash current with 240 possible current levels. The maximum movie mode current is set by Address register 3 (discussed below). The default ratio between the maximum movie mode current level and the flash current level is 1:7.3. The corresponding FL maximum movie mode current can be calculated:

$$I_{MOVIE\ MODE} = \frac{I_{FLMAX}}{7.3}$$

For example, if an  $R_{SET}$  value of 107kΩ is chosen, then the FL flash current is set to 1500mA. For movie mode operation, the maximum current available at FL is then:

$$I_{MOVIE\ MODE} = \frac{I_{FLMAX}}{7.3} = \frac{1500mA}{7.3} = 206mA$$

Address 0 controls precise movie mode current levels. The FL movie-mode current can be adjusted in logarithmic fashion to one of 16 steps represented as a fraction of the maximum movie mode current in Table 2. To adjust the movie-mode current the user must first access Address 0 before writing the data to set the MM Current value.

Data	Percentage of Maximum MM Current
1*	100%
2	89%
3	79%
4	71%
5	63%
6	56%
7	50%
8	45%
9	40%
10	36%
11	32%
12	28%
13	25%
14	22%
15	20%
16	0%

**Table 2: Address 0, Movie Mode Current Programming.**

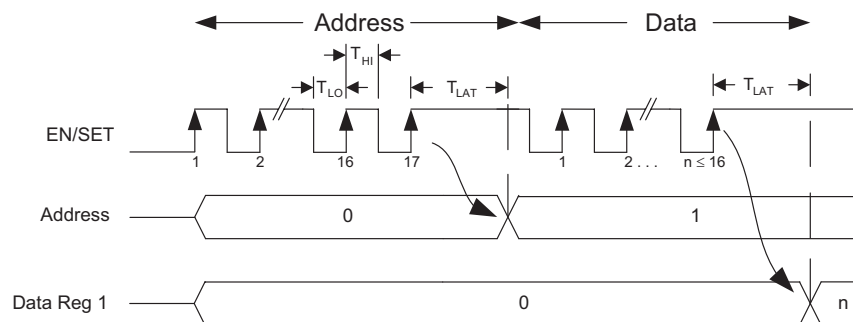

**Figure 1: AS<sup>2</sup>Cwire™ Serial Interface Timing.**

\* Denotes the default value.

### Flash/Safety Timer – Address 1

A timer function that enables the flash current sinks for a programmed amount of time is incorporated in the AAT1290. The on-time is programmed by loading the Timing Register at Address 1 with a value from 1 to 16 and by choosing a value for the external timing capacitor,  $C_T$  (see Table 3). When data is latched into Address 1, the data will be used at the next occurrence of an asserted FLEN, it will then revert to the default value of Data 1, or 16/16. This feature eliminates the need for an external, housekeeping baseband controller to contain a safety delay routine. The flash safety timer also serves as a protection feature to minimize thermal issues with the flash LEDs in the event the external controller's flash routine experiences a software failure. If no write instruction is applied to Address 1, then the safety timer will default to the maximum delay programmed externally by  $C_T$ .

The Flash Time T can be calculated by the following equation:

$$t = \frac{8.82s}{\mu F} \cdot C_T(\mu F)$$

Where T is in seconds and  $C_T$  is in  $\mu F$ .

For example, using a 47nF capacitor at  $C_T$  sets the flash timeout to:

$$\text{Flash Timeout} = \frac{8.82s}{\mu F} \cdot 68nF = 600ms$$

The relationship between the flash safety timeout and the capacitance of the timer capacitor is illustrated in Figure 2.

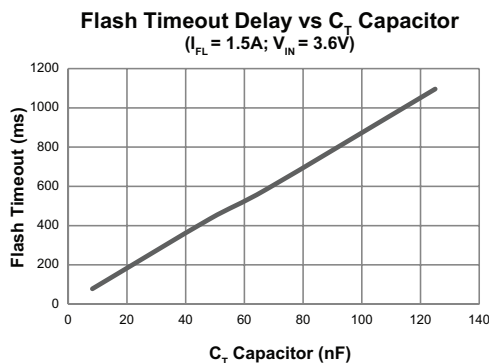

Figure 2: Flash Safety Timeout vs. Timer Capacitor.

Data	Ratio of MM Timeout
1*	16/16
2	15/16
3	14/16
4	13/16
5	12/16
6	11/16
7	10/16
8	9/16
9	8/16
10	7/16
11	6/16
12	5/16
13	4/16
14	3/16
15	2/16
16	1/16

Table 3: Address 1, Flash Safety Timer Programming; Maximum Value Programmed by  $C_T$ .

### Movie Mode Enable – Address 2

To enable or disable the flash, a write instruction to Address 2 is applied to the AAT1290's EN/SET pin. If no write instruction is applied, the default value for Address 2 is OFF. During a flash event, the LED will be enabled regardless of the movie-mode setting.

Data	Movie Mode Enable
1*	OFF <sup>1</sup>
2	OFF <sup>1</sup>
3	ON
4	ON

Table 4: Address 2, Movie Mode Output Configuration.

<sup>1</sup> A small current will flow due to the start-up test current.  
\* Default value.

### Maximum Movie to Flash Mode Current Ratio – Address 3

The maximum movie-mode current is a fixed ratio of the flash current controlled by Address 3. The ratio may be varied from 1:2 to OFF in 16 linear steps as shown in Table 5. The default value for Address 3 is Data=4 and represents a flash to maximum movie mode current level of 7.3 to 1.

Data	MM to FL Ratio
1	1/1.92
2	1/3.7
3	1/5.5
4*	1/7.3
5	1/9
6	1/10.7
7	1/12.4
8	1/14
9	1/15.9
10	1/17.5
11	1/19.1
12	1/20.8
13	1/22.4
14	1/24
15	1/25.6
16	OFF <sup>1</sup>

**Table 5: Address 3, Movie/Flash Mode Current Ratio.**

\* Denotes the default value.

The default maximum movie mode current can be calculated:

$$I_{\text{MOVIE MODE}} = \frac{I_{\text{FLMAX}}}{7.3}$$

For example, if an  $R_{\text{SET}}$  value of 107kΩ is chosen, then the FL flash current is set to 1500mA. For movie mode operation, the maximum current available at FL is then:

$$I_{\text{MOVIE MODE}} = \frac{I_{\text{FLMAX}}}{7.3} = \frac{1500\text{mA}}{7.3} = 206\text{mA}$$

The maximum movie mode current level can be calculated using the following equation:

$$I_{\text{MOVIE MODE}} = \frac{162\text{k}\Omega \times A}{R_{\text{SET}}} \cdot \text{MM to FL Ratio} = \text{Max Movie Mode Current}$$

### Shutdown

Since the sink switches are the only power returns for all loads, there is no leakage current to the load when the sink switches are disabled. When EN/SET pin is held low for an amount of time greater than  $t_{\text{OFF}}$  (500μs), the AAT1290 enters shutdown mode and draws less than 1μA from  $V_{\text{IN}}$ . All data and address registers are cleared (reset to 0) during shutdown.

### Selecting the Boost Inductor

The AAT1290 DC/DC boost controller utilizes PWM control with a fixed switching frequency. To maintain a 2MHz maximum switching frequency and stable operation, a 1μH inductor is recommended. Manufacturer’s specifications list both the inductor DC current rating, which is a thermal limitation, and peak inductor current rating, which is determined by the saturation characteristics. Measurements at full load and high ambient temperature should be performed to ensure that the inductor does not saturate or exhibit excessive temperature rise.

Manufacturer	Part Number	Inductance (μH)	Saturated Rated Current (A)	DCR (mΩ)	Size (mm) LxWxH	Type
Cooper Bussmann	SD3812-1R0-R	1	2.69	48	4.0x4.0x1.2	Shielded Drum Core
Cooper Bussmann	SDH3812-1R0-R	1	3	45	3.8x3.8x1.2	Shielded Drum Core
Cooper Bussmann	SD10-1R0-R	1	2.25	44.8	5.2x5.2x1.0	Shielded Drum Core
Sumida	CDH38D11/S	1	2.8	48.8	4.0x4.0x1.2	Shielded Drum Core
Coilcraft	LPS4012-102NLC	1	2.5	60	4.1x4.1x1.2	Shielded Drum Core

**Table 6: Typical Suggested Surface Mount Inductors.**

1. A small current will flow due to the short circuit test current.

The inductor (L) is selected to avoid saturation at minimum input voltage and maximum output load conditions. Worst-case peak current occurs at minimum input voltage (maximum duty cycle) and maximum load. Bench measurements are recommended to confirm actual  $I_{PEAK}$  and to ensure that the inductor does not saturate at maximum LED current and minimum input supply voltage. The RMS current flowing through the boost inductor is equal to the DC plus AC ripple components. Under worst case RMS conditions, the current waveform is critically continuous. The resulting RMS calculation yields worst case inductor loss. The RMS current value should be compared against the inductor manufacturer’s temperature rise, or thermal derating guidelines:

$$I_{RMS} = \frac{I_{PEAK}}{\sqrt{3}}$$

For a given inductor type, smaller inductor size leads to an increase in DCR winding resistance and, in most cases, increased thermal impedance. Winding resistance degrades boost converter efficiency and increases the inductor’s operating temperature:

$$P_{LOSS(INDUCTOR)} = I_{RMS}^2 \cdot DCR$$

**Selecting the Boost Capacitors**

It is good design practice to place a decoupling capacitor (input capacitor) between the IN and GND pins. An input capacitor in the range of 2.2µF to 10µF is recommended. A larger input capacitor in this application may be required for stability, transient response, and/or ripple performance. The high output ripple inherent in the boost converter necessitates the use of low impedance output filtering. Multi-layer ceramic (MLC) capacitors provide small size and adequate capacitance, low parasitic equivalent series resistance (ESR) and equivalent series inductance (ESL), and are well suited for use with the AAT1290 boost regulator. MLC capacitors of type X7R or X5R are recommended to ensure good capacitance stability over the full operating temperature range. The output capacitor is selected to maintain the output load without significant voltage droop ( $\Delta V_{OUT}$ ) during the power switch ON interval. A 2.2µF ceramic output capacitor is recommended (see Table 7). Typically, 6.3V or 10V rated capacitors are required for this flash LED boost output. Ceramic capacitors selected as small as 0603 are available which meet these requirements. MLC capacitors exhibit significant capacitance reduction with applied voltage. Output ripple measurements should confirm that output voltage droop and operating stability are within acceptable limits. Voltage derating can minimize this factor, but results may vary with package size and among specific manufacturers. To maintain stable operation at full load, the output capacitor should be selected to maintain  $\Delta V_{OUT}$  between 100mV and 200mV. The boost converter input current flows during both ON and OFF switching intervals. The input ripple current is less than the output ripple and, as a result, less input capacitance is required.

Manufacturer	Part Number	Capacitance (µF)	Voltage Rating (V)	Temp Co.	Case Size
Murata	GRM185R60J225KE26	2.2	6.3	X5R	0603
	GRM188R71A225KE15	2.2	10	X7R	0603
	GRM21BR70J225KA01	2.2	6.3	X7R	0805
	GRM21BR71A225KA01	2.2	10	X7R	0805
	GRM219R61A475KE19	4.7	10	X5R	0805
	GRM21BR71A106KE51	10	10	X7R	0805

**Table 7: Typical Suggested Surface Mount Capacitors.**

### PCB Layout Guidelines

Boost converter performance can be adversely affected by poor layout. Possible impact includes high input and output voltage ripple, poor EMI performance, and reduced operating efficiency. Every attempt should be made to optimize the layout in order to minimize parasitic PCB effects (stray resistance, capacitance, and inductance) and EMI coupling from the high frequency SW node. A suggested PCB layout for the AAT1290 1.5A step-up regulator is shown in Figures 4 and 5. The following PCB layout guidelines should be considered:

1. Minimize the distance from capacitor  $C_{IN}$  and  $C_{OUT}$ 's negative terminals to the PGND pins. This is especially true with output capacitor  $C_{OUT}$ , which conducts high ripple current from the output to the PGND pins.

2. Minimize the distance under the inductor between IN and switching pin SW; minimize the size of the PCB area connected to the SW pin.
3. Maintain a ground plane and connect to the IC PGND pin(s) as well as the PGND connections of  $C_{IN}$  and  $C_{OUT}$ .
4. Consider additional PCB exposed area for the flash LEDs to maximize heatsinking capability. This may be necessary when using high current application and long flash duration application.
5. Connect the exposed paddle (bottom of the die) to PGND. Connect AGND, FLGND to PGND as close as possible to the package.

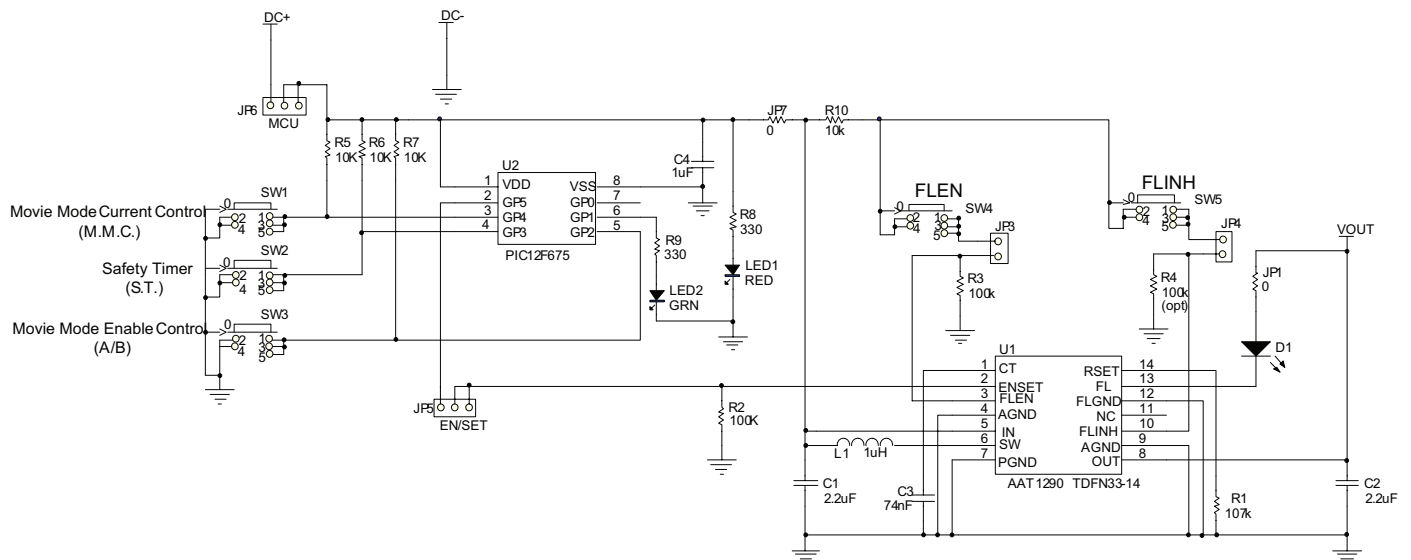
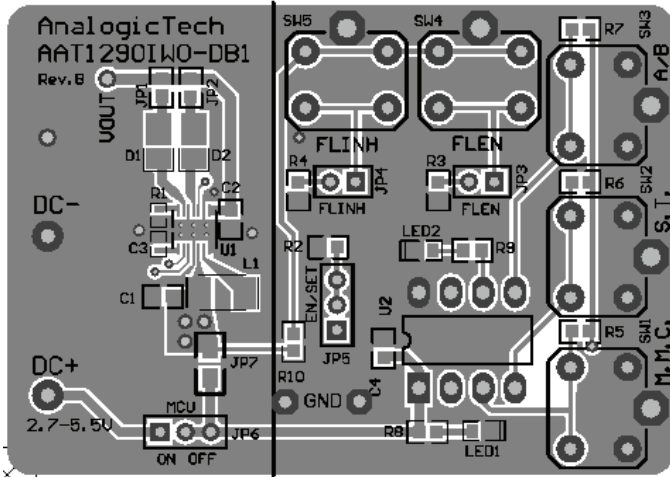
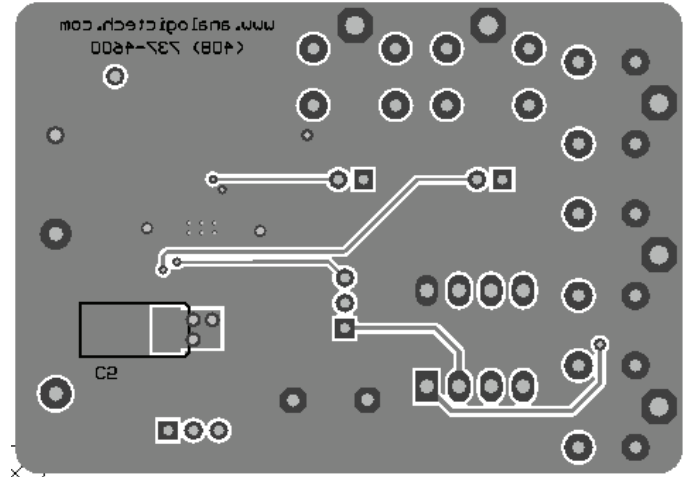

Figure 3: AAT1290 Evaluation Board Schematic.



**Figure 4: AAT1290 Evaluation Board Top Side Layout.**



**Figure 5: AAT1290 Evaluation Board Bottom Side Layout.**

Component	Part Number	Description	Manufacturer
U1	AAT1290IWO	1.5A Step-Up Current Regulator for Flash LEDs; TDFN33-14 package	AnalogicTech
U2	PIC12F675	8-bit CMOS, FLASH-based $\mu$ C; 8-pin PDIP package	Microchip
SW1 - SW5	PTS645TL50	Switch, SPST, 5mm	ITT Industries
R1	Chip Resistor	107k $\Omega$ , 1%, 1/4W; 0402	Vishay
R2, R3, R4	Chip Resistor	100k $\Omega$ , 1%, 1/4W; 0603	Vishay
R5, R6, R7, R10	Chip Resistor	10k $\Omega$ , 1%, 1/4W; 0603	Vishay
R8, R9	Chip Resistor	330 $\Omega$ , 1%, 1/4W; 0603	Vishay
JP1, JP2(Not Mounted), JP7	Chip Resistor	0 $\Omega$ , 1%	Vishay
C1, C2	GRM-188R71A225KE15	2.2 $\mu$ F, 10V, X7R, 0603	Murata
C3	GRM155R71A-743KA01	74nF, 10V, X7R, 0402	Murata
C4	GRM216R61A-105KA01	1 $\mu$ F, 10V, X5R, 0805	Murata
L1	SD3812-1R0-R	Drum Core, 1 $\mu$ H, 2.69A, 48m $\Omega$	Cooper Bussmann
D1, D2(Not Mounted)	LXCL-PWF4	White Flash LED	Lumileds, Philips
LED1	CMD15-21SRC/TR8	Red LED; 1206	Chicago Miniature Lamp
LED2	CMD15-21VGC/TR8	Green LED; 1206	Chicago Miniature Lamp
JP3, JP4, JP5, JP6	PRPN401PAEN	Conn. Header, 2mm zip	Sullins Electronics

Table 8: AAT1290 Evaluation Board Bill of Materials.

### Ordering Information

Package	Marking <sup>1</sup>	Part Number (Tape and Reel) <sup>2</sup>
TDFN33-14	U6XYY	<b>AAT1290IWO-T1</b>



All AnalogicTech products are offered in Pb-free packaging. The term “Pb-free” means semiconductor products that are in compliance with current RoHS standards, including the requirement that lead not exceed 0.1% by weight in homogeneous materials. For more information, please visit our website at <http://www.analogictech.com/aboutus/quality.php>.

### Package Information

#### TDFN33-14<sup>3</sup>

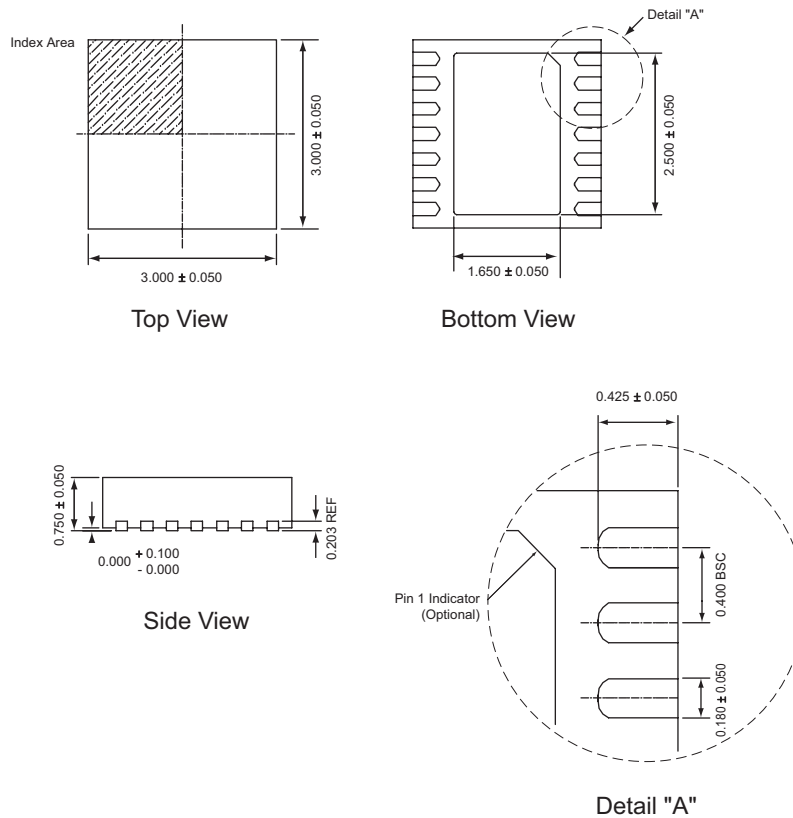

All dimensions in millimeters.

1. XYY = assembly and date code.  
 2. Sample stock is generally held on part numbers listed in **BOLD**.  
 3. The leadless package family, which includes QFN, TQFN, DFN, TDFN, and STDFN, has exposed copper (unplated) at the end of the lead terminals due to the manufacturing process. A solder fillet at the exposed copper edge cannot be guaranteed and is not required to ensure a proper bottom solder connection.

**SwitchReg™****1.5A Step-Up Current Regulator for Flash LEDs**

**Advanced Analogic Technologies, Inc.**  
3230 Scott Boulevard, Santa Clara, CA 95054  
Phone (408) 737-4600  
Fax (408) 737-4611



© Advanced Analogic Technologies, Inc.  
AnalogicTech cannot assume responsibility for use of any circuitry other than circuitry entirely embodied in an AnalogicTech product. No circuit patent licenses, copyrights, mask work rights, or other intellectual property rights are implied. AnalogicTech reserves the right to make changes to their products or specifications or to discontinue any product or service without notice. Except as provided in AnalogicTech's terms and conditions of sale, AnalogicTech assumes no liability whatsoever, and AnalogicTech disclaims any express or implied warranty relating to the sale and/or use of AnalogicTech products including liability or warranties relating to fitness for a particular purpose, merchantability, or infringement of any patent, copyright or other intellectual property right. In order to minimize risks associated with the customer's applications, adequate design and operating safeguards must be provided by the customer to minimize inherent or procedural hazards. Testing and other quality control techniques are utilized to the extent AnalogicTech deems necessary to support this warranty. Specific testing of all parameters of each device is not necessarily performed. AnalogicTech and the AnalogicTech logo are trademarks of Advanced Analogic Technologies Incorporated. All other brand and product names appearing in this document are registered trademarks or trademarks of their respective holders.