

Toshiba Intelligent Power Device Silicon Monolithic Power MOS Integrated Circuit

TPD1053F

Motor, Solenoid, Lamp Drivers
High-side Power Switch

The TPD1053F is a monolithic power IC for high-side switches. The IC has a vertical MOSFET output which can be directly driven from a CMOS or TTL logic circuit (e.g., an MPU). The device offers intelligent self-protection and diagnostic functions.

Features

- A monolithic power IC with a structure combining a control block (Bi-CMOS) and a vertical power MOSFET on a single chip.
- One side of load can be grounded to a high-side switch.
- Can directly drive a power load from a microprocessor.
- Built-in protection against over temperature and load short-circuiting.
- Incorporates a diagnosis function that allows diagnosis output to be read externally at load short-circuiting, opening, or over temperature.
- Up to -16(Typ.) of counter electromotive force from an inductance load can be applied.
- Low on-resistance : $R_{DS(ON)}=0.12\Omega(\text{Max})$ (@ $V_{DD} = 12 \text{ V}$, $T_{ch} = 25^\circ\text{C}$, $I_O = 2 \text{ A}$)
- 8-pin SOP package for surface mounting that can be packed in tape.

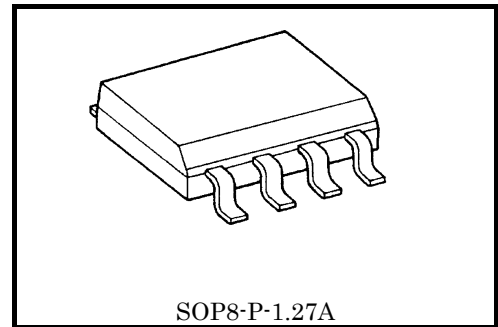

Weight: 0.08 g (Typ.)

Pin Assignment

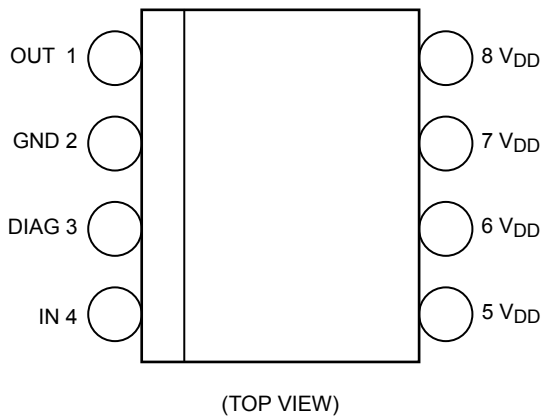

Marking

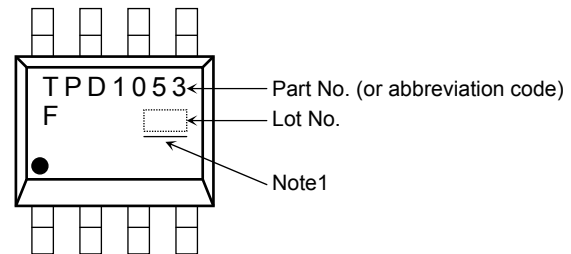

• on the lower left of the marking indicates Pin 1.

* Weekly code : (Three digits)

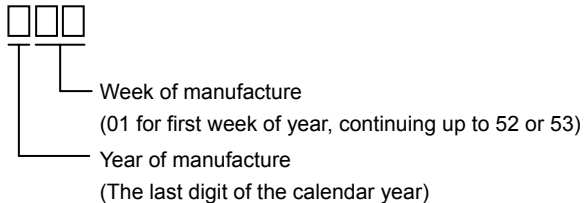

Note 1 : A line under a Lot No. identifies the indication of product Labels.

Not underlined : $[[\text{Pb}]]/\text{INCLUDES} > \text{MCV}$

Underlined : $[[\text{G}]]/\text{RoHS COMPATIBLE}$ or $[[\text{G}]]/\text{RoHS}[[\text{Pb}]]$

Please contact your TOSHIBA sales representative for details as to environmental matters such as the RoHS compatibility of Product. The RoHS is the Directive 2002/95/EC of the European Parliament and of the Council of 27 January 2003 on the restriction of the use of certain hazardous substances in electrical and electronic equipment.

Due to its MOS structure, this product is sensitive to static electricity.

Timing Chart

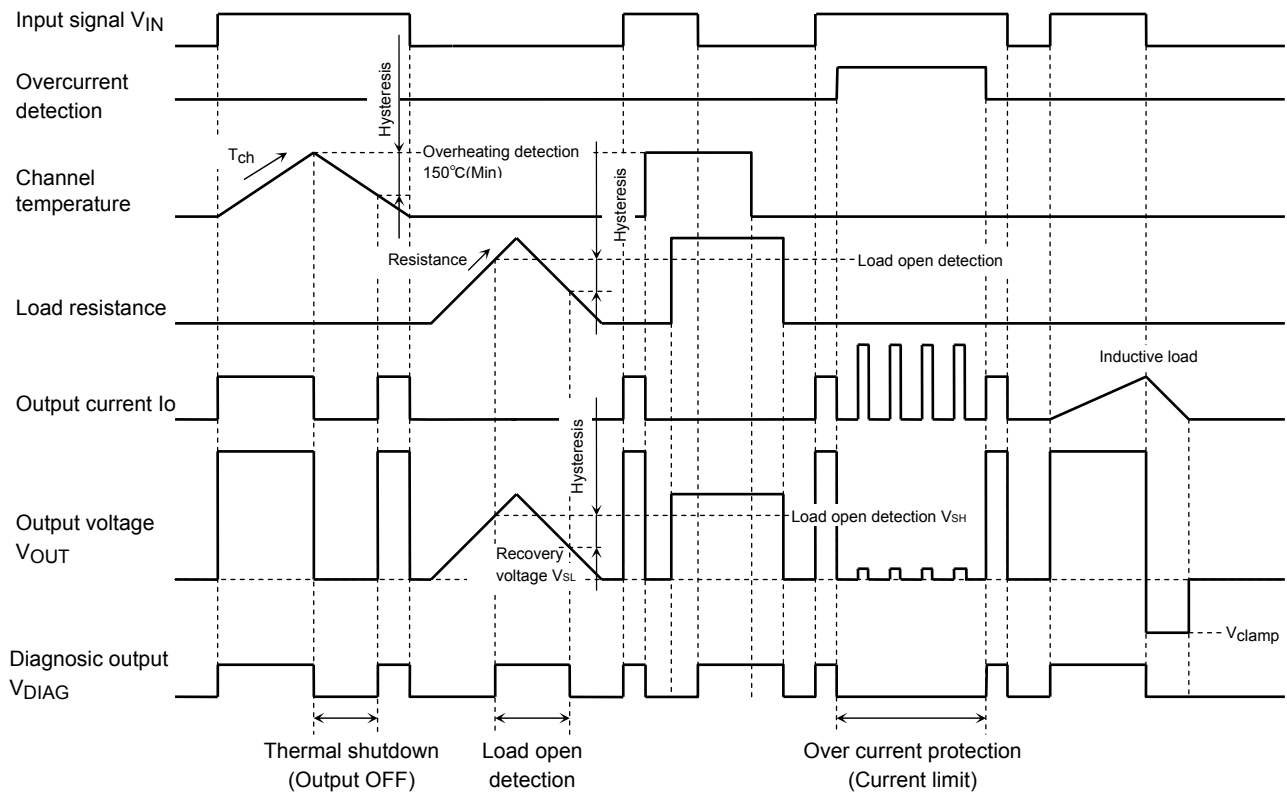

Truth Table

Input signal V_{IN}	Output voltage V_{OUT}	Output state	Operating state
L	L	off	Normal
H	H	on	
L	H (Note 2)	off	Load open
H	H	on	
L	L	off	Load short
H	L	Current limit (Switching)	
L	L	off	Over temperature
H	L	off	

Note 2: Internal voltage in TPD1053F and external voltage decide this output voltage.

Input signal V_{IN}	Output voltage V_{OUT}	Diagnosis V_{DIAG}	Diagnosis state
L	$V_{OUT} < V_{SL}$	L	Normally off
	$V_{OUT} \geq V_{SH}$	H	Load open
H	$V_{OUT} \geq V_{DD} - V_{OC}$	H	Normally on
	$V_{OUT} < V_{DD} - V_{OC}$	L	Over current (Load short), Over temperature

V_{SH}, V_{SL} : Schmitt inverter threshold voltage ($V_{SH}=2.2\text{V}(\text{Typ.})$, $V_{SL}=1.8\text{V}(\text{Typ.})$) @ $V_{DD}=12\text{V}$, $T_{ch}=25^{\circ}\text{C}$

V_{OC} : Over current detection threshold voltage

Absolute Maximum Ratings (T_a = 25°C)

Characteristics	Symbol	Rating	Unit
Drain-source voltage	V _{DS}	60	V
Supply voltage	DC	V _{DD(1)}	-0.5 to 25
	Pulse	V _{DD(2)}	60(R _S =1Ω,τ=250ms)
Input voltage	DC	V _{IN(1)}	-0.5 to 12
	Pulse	V _{IN(2)}	V _{DD(1)} +1.5(t=100ms)
Diagnosis output voltage	V _{DIAG}	-0.5 to 25	V
Output current	I _O	Internally Limited	A
Input current	I _{IN}	±10	mA
Diagnosis current	I _{DIAG}	5	mA
Power dissipation (Note 3-a)	P _{D(1)}	1.1	W
Power dissipation (Note 3-b)	P _{D(2)}	0.425	W
Operating temperature	T _{opr}	-40 to 125	°C
Channel temperature	T _{ch}	150	°C
Storage temperature	T _{stg}	-55 to 150	°C

Note: Using continuously under heavy loads (e.g. the application of high temperature/current/voltage and the significant change in temperature, etc.) may cause this product to decrease in the reliability significantly even if the operating conditions (i.e. operating temperature/current/voltage, etc.) are within the absolute maximum ratings and the operating ranges.

Please design the appropriate reliability upon reviewing the Toshiba Semiconductor Reliability Handbook (“Handling Precautions”/“Derating Concept and Methods”) and individual reliability data (i.e. reliability test report and estimated failure rate, etc).

Thermal Resistance

Characteristic	Symbol	Rating	Unit
Thermal resistance	R _{th(ch-a)}	113.5 (Note 3a)	°C /W
		294.0 (Note 3b)	

Note 3:

3-a : Glass epoxy board (a)

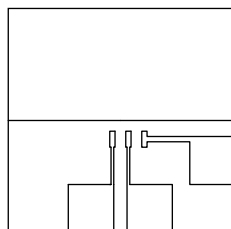

FR-4
25.4 × 25.4 × 0.8
(Unit : mm)

3-b : Glass epoxy board (b)

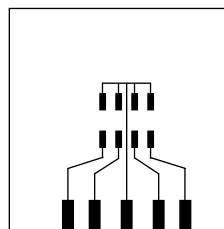

FR-4
25.4 × 25.4 × 0.8
(Unit : mm)

Electrical Characteristics (Unless otherwise specified, $T_{ch} = -40$ to $125\text{ }^{\circ}\text{C}$, $V_{DD} = 5$ to 18 V)

Characteristics	Symbol	Test circuit	Test condition	Min	Typ.	Max	Unit
Operating supply voltage	$V_{DD(opr)}$	-	-	5	12	18	V
Supply current	$I_{DD(off)}$	-	$V_{IN}=0V$, Output open	-	0.8	4.5	mA
	$I_{DD(on)}$	-	$V_{IN}=5V$, Output open	-	1.4	5	mA
Input voltage	V_{IH}	-	$V_{DD}=8$ to $18V$	3.5	-	-	V
	V_{IL}	-	$V_{DD}=8$ to $18V$	-	-	1.5	V
Input current	$I_{IN(1)}$	-	$V_{IN}=5V$	-	25	200	μA
	$I_{IN(2)}$	-	$V_{IN}=0V$	-1	-	1	μA
On resistance	$R_{DS(ON)}$	-	$V_{DD}=8$ to $18V$, $I_O=2A$, $T_{ch}=25^{\circ}\text{C}$	-	0.09	0.12	Ω
Output leakage current	I_{OL}	-	$V_{IN}=0V$, $V_{OUT}=0V$	-	0.2	2	mA
Diagnosis output voltage	"L"-level V_{DL}	-	$I_{DIAG}=1\text{mA}$	-	-	0.4	V
Diagnosis output current	"H"-level I_{DH}	-	$V_{DIAG}=18V$	-	-	10	μA
Over current detection	I_{OC}	1, 2	$V_{DD}=8$ to $18V$	3	6	9	A
Over temperature detection	Temperature T_{OT}	-	-	150	170	200	$^{\circ}\text{C}$
	Hysteresis ΔT_{OT}	-	-	-	10	-	$^{\circ}\text{C}$
Load open detection	R_{OP}	3	$V_{DD}=8$ to $18V$, $V_{IN}=0V$	0.5	15	250	$\text{k}\Omega$
Switching time	t_{on}	4	$V_{DD}=12V$, $R_L=10\Omega$, $T_{ch}=25^{\circ}\text{C}$	-	50	100	μs
	t_{off}			-	40	80	μs
Diagnosis delay time	t_{DLH}	5	$V_{DD}=12V$, $R_L=10\Omega$, $T_{ch}=25^{\circ}\text{C}$	-	40	-	μs
	t_{DHL}			-	40	-	μs
Output clamp voltage	V_{clamp}	-	$V_{IN}=0V$, $I_O=1A$, $T_{ch}=25^{\circ}\text{C}$	-25	-16	-10	V

*Typical characteristic conditions are $V_{DD}=12V$, $T_{ch}=25^{\circ}\text{C}$.

Test Circuit 1

Over current detection I_{OC} : Over current detection when load current is increased while $V_{IN} = "H"$.

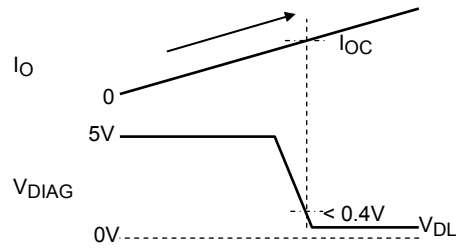
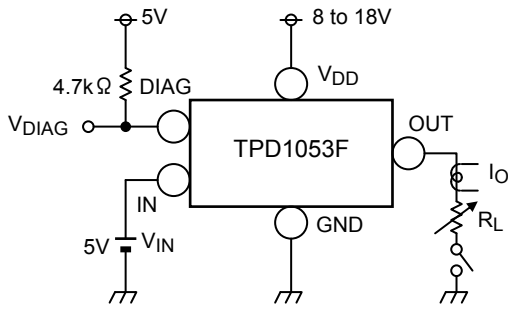

Test Circuit 2

Over current detection I_{OC} : Over current detection when load is short circuit and $V_{IN} = "L" \rightarrow "H"$

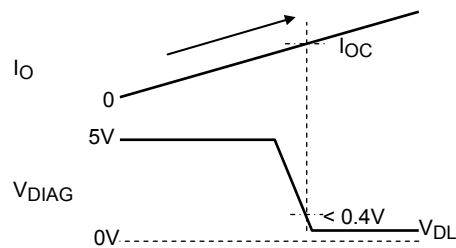
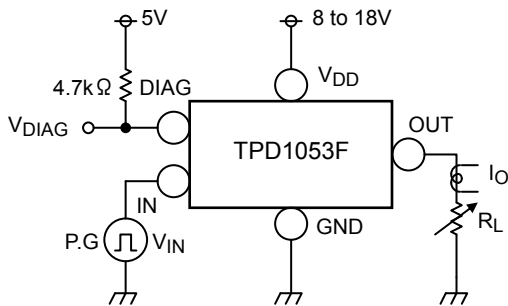

Test Circuit 3

Load open detection R_{OP}

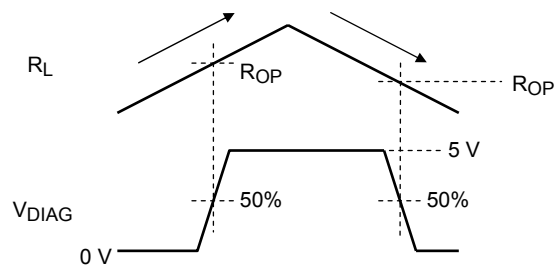
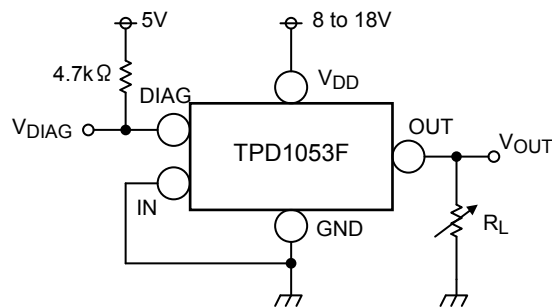

Test Circuit 4

Switching times t_{on} , t_{off}

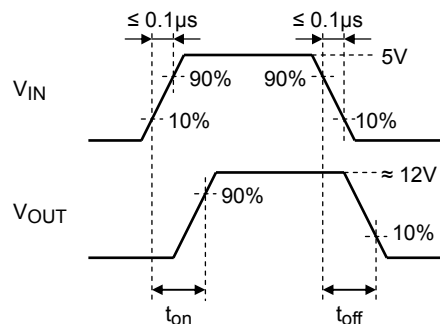
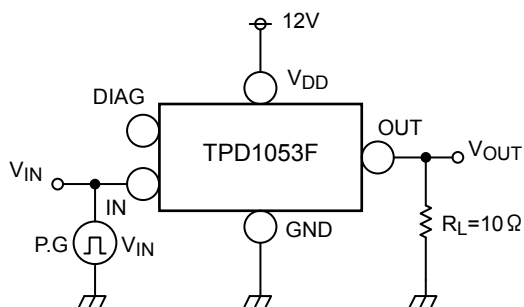

Test Circuit 5

Diagnosis delay time t_{DLH} , t_{DLH}

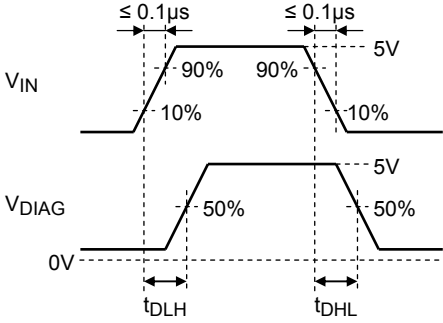
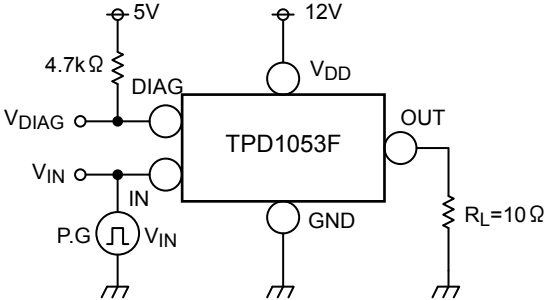

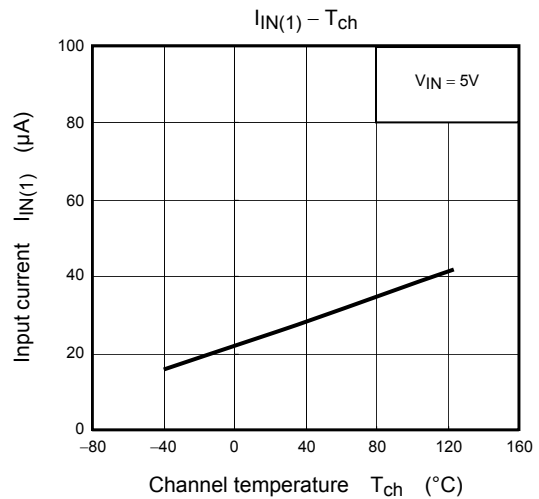
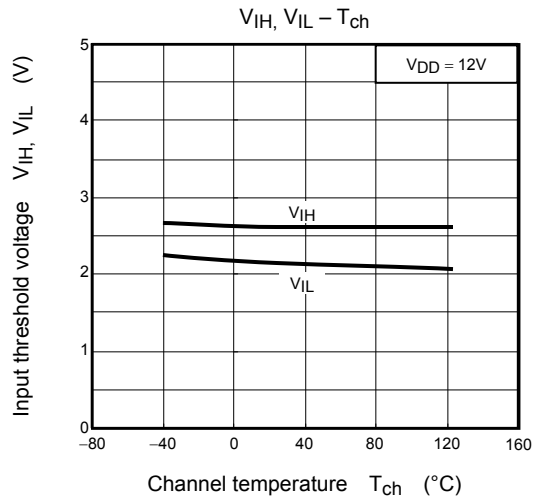
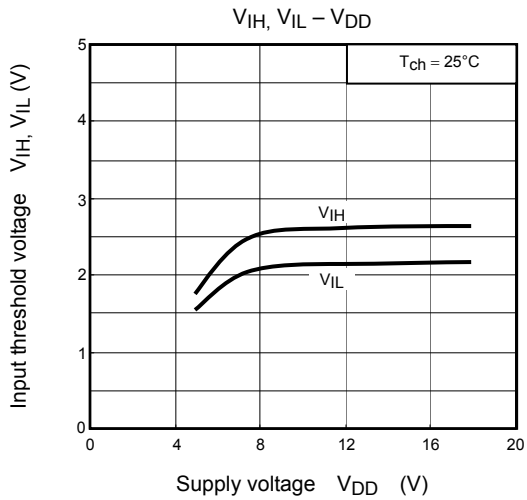
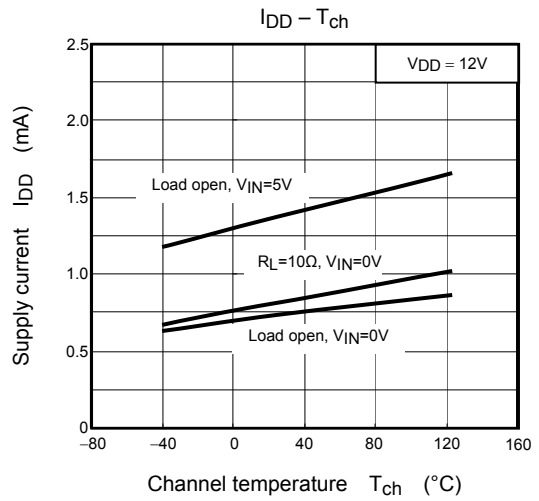
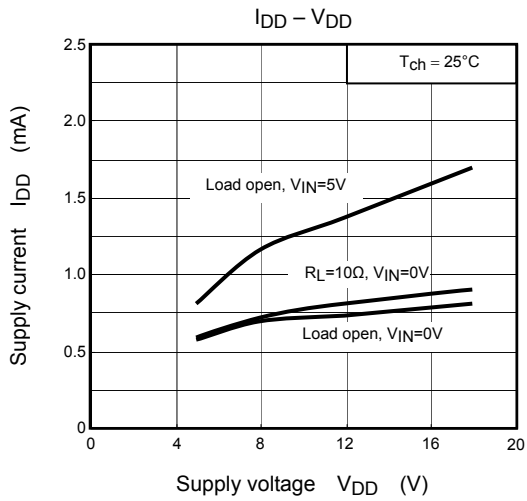

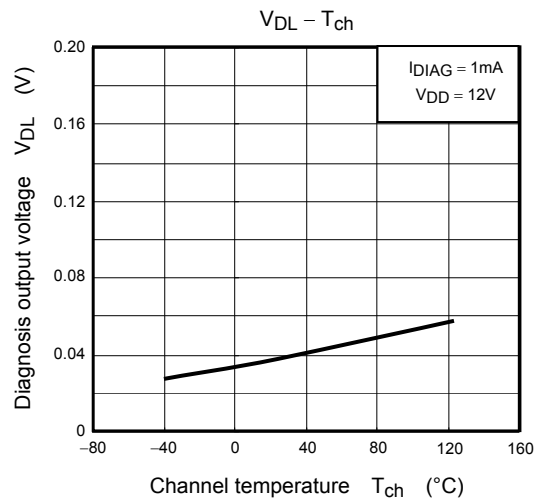
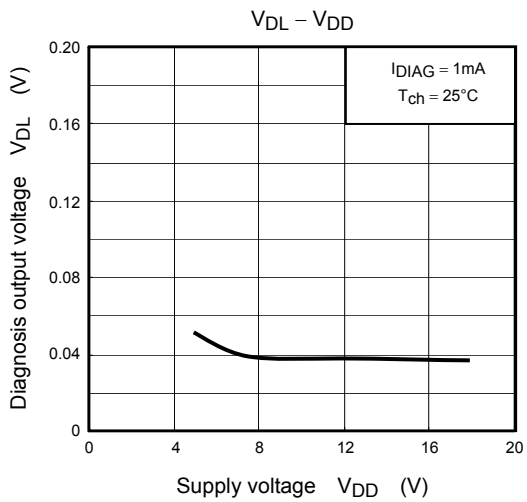
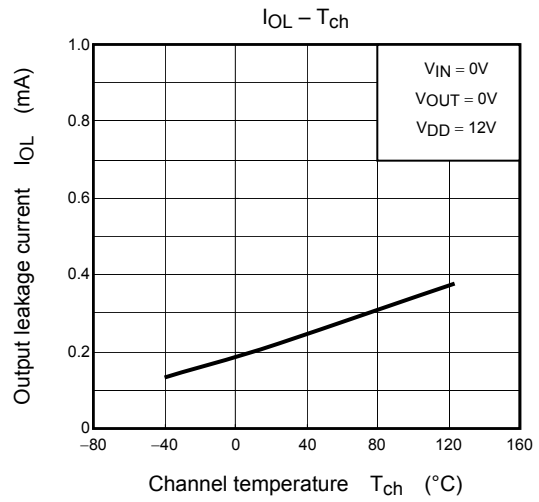
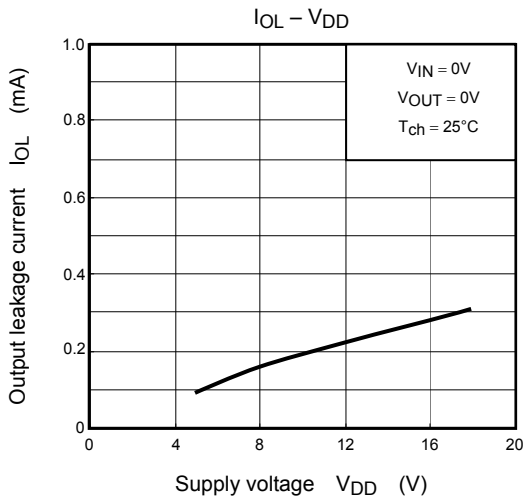
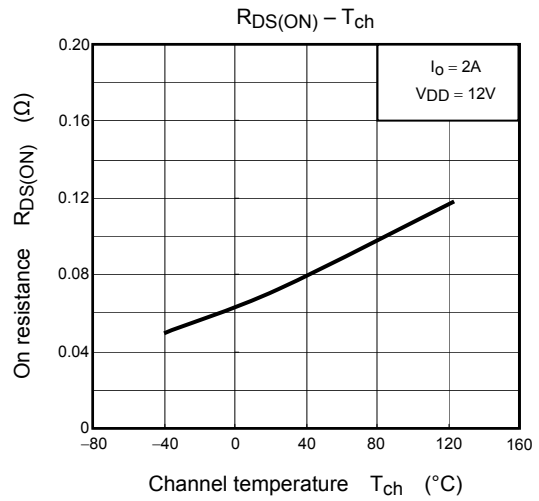
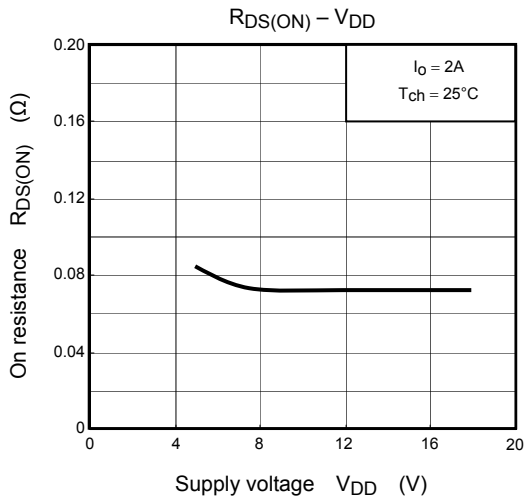

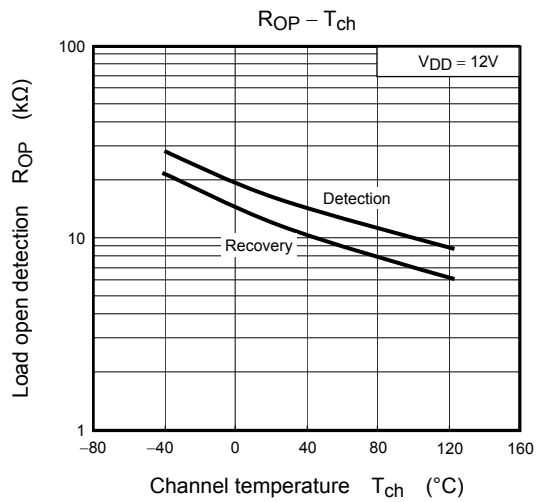
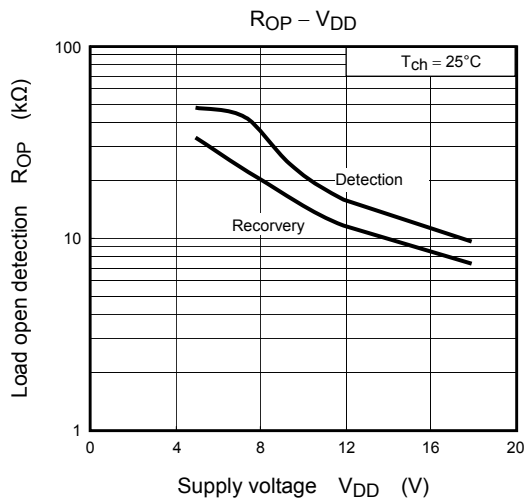
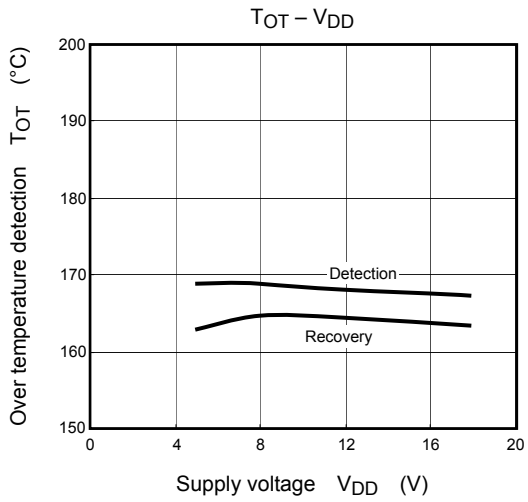
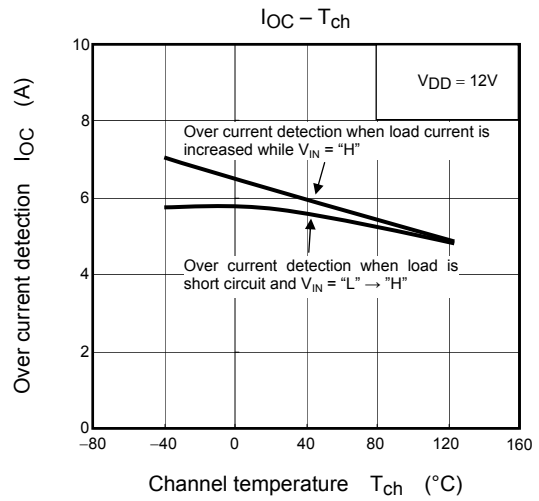
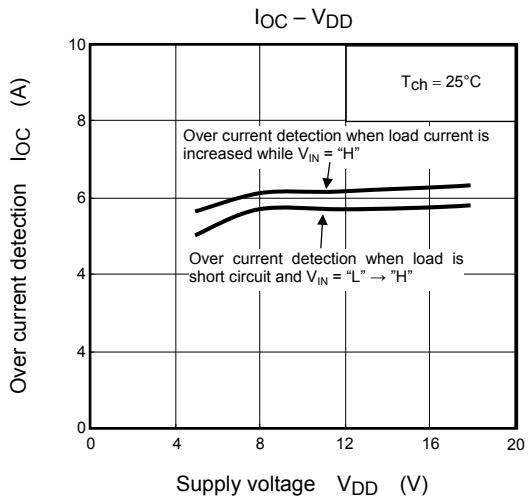

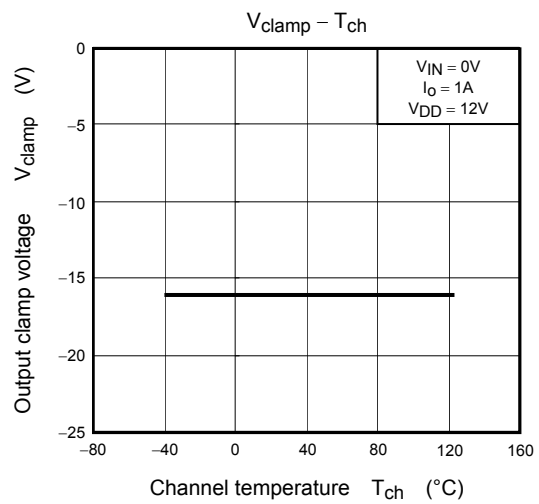
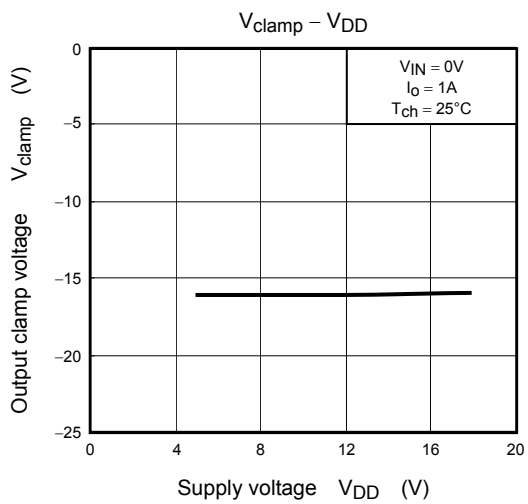
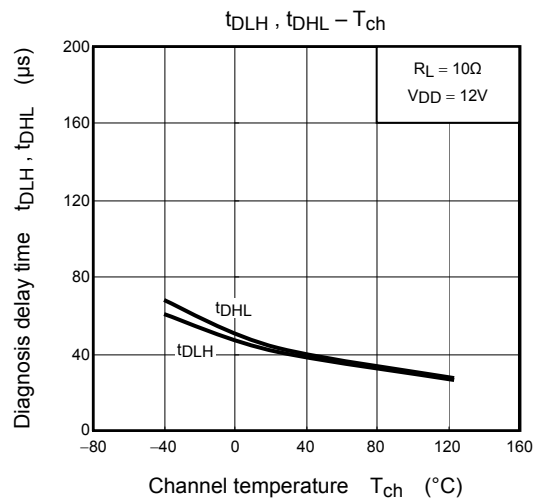
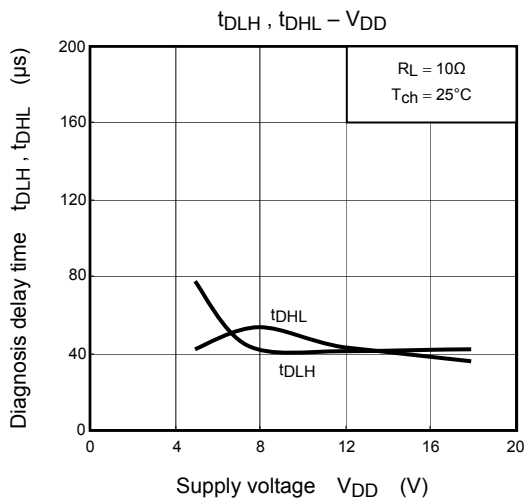
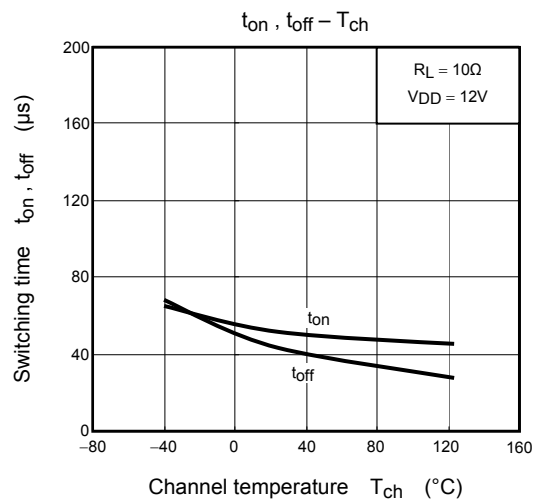
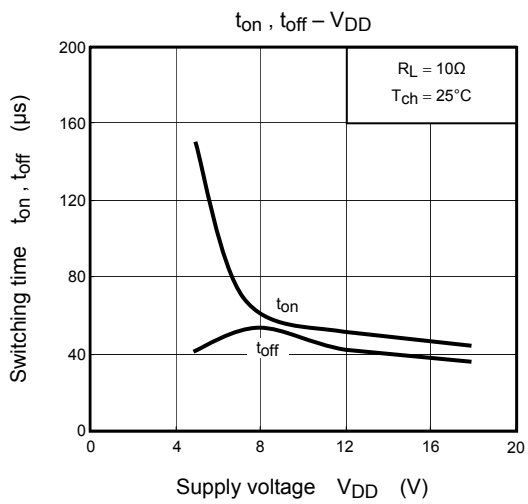

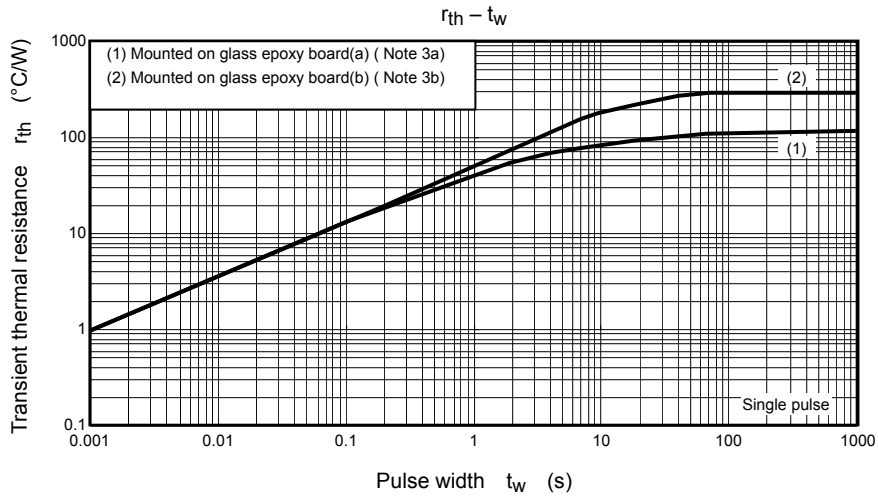
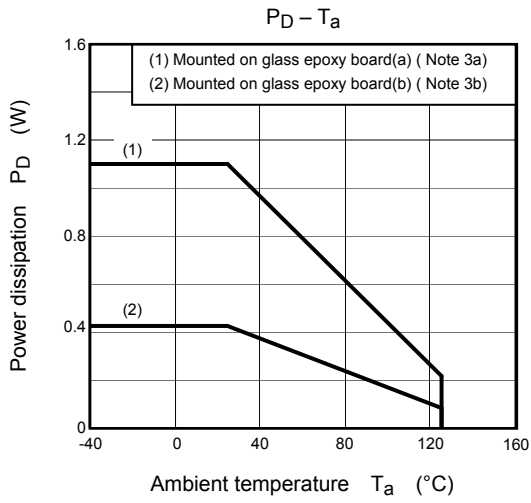

Package Dimensions

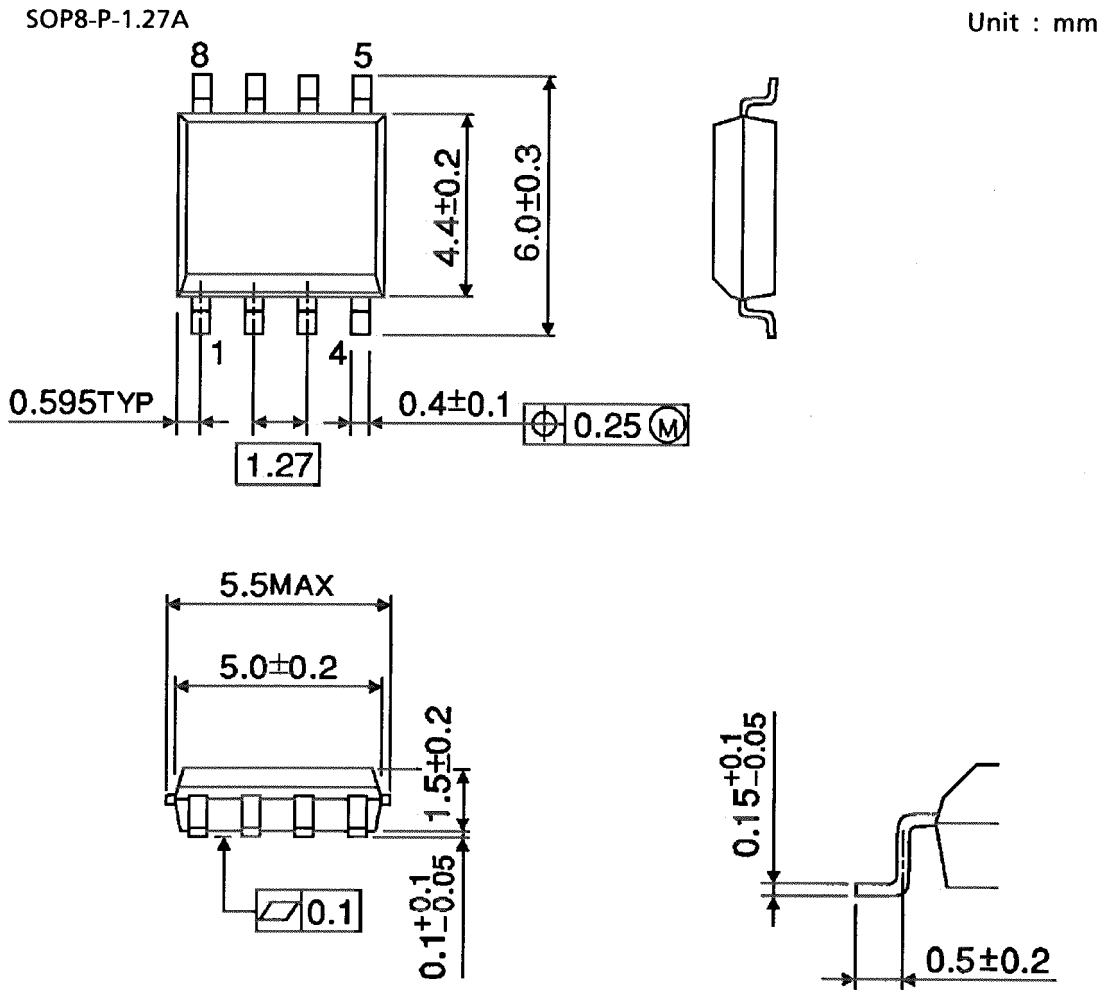

Weight: 0.08 g (Typ.)

RESTRICTIONS ON PRODUCT USE

- Toshiba Corporation, and its subsidiaries and affiliates (collectively "TOSHIBA"), reserve the right to make changes to the information in this document, and related hardware, software and systems (collectively "Product") without notice.
- This document and any information herein may not be reproduced without prior written permission from TOSHIBA. Even with TOSHIBA's written permission, reproduction is permissible only if reproduction is without alteration/omission.
- Though TOSHIBA works continually to improve Product's quality and reliability, Product can malfunction or fail. Customers are responsible for complying with safety standards and for providing adequate designs and safeguards for their hardware, software and systems which minimize risk and avoid situations in which a malfunction or failure of Product could cause loss of human life, bodily injury or damage to property, including data loss or corruption. Before customers use the Product, create designs including the Product, or incorporate the Product into their own applications, customers must also refer to and comply with (a) the latest versions of all relevant TOSHIBA information, including without limitation, this document, the specifications, the data sheets and application notes for Product and the precautions and conditions set forth in the "TOSHIBA Semiconductor Reliability Handbook" and (b) the instructions for the application with which the Product will be used with or for. Customers are solely responsible for all aspects of their own product design or applications, including but not limited to (a) determining the appropriateness of the use of this Product in such design or applications; (b) evaluating and determining the applicability of any information contained in this document, or in charts, diagrams, programs, algorithms, sample application circuits, or any other referenced documents; and (c) validating all operating parameters for such designs and applications. **TOSHIBA ASSUMES NO LIABILITY FOR CUSTOMERS' PRODUCT DESIGN OR APPLICATIONS.**
- Product is intended for use in general electronics applications (e.g., computers, personal equipment, office equipment, measuring equipment, industrial robots and home electronics appliances) or for specific applications as expressly stated in this document. Product is neither intended nor warranted for use in equipment or systems that require extraordinarily high levels of quality and/or reliability and/or a malfunction or failure of which may cause loss of human life, bodily injury, serious property damage or serious public impact ("Unintended Use"). Unintended Use includes, without limitation, equipment used in nuclear facilities, equipment used in the aerospace industry, medical equipment, equipment used for automobiles, trains, ships and other transportation, traffic signaling equipment, equipment used to control combustions or explosions, safety devices, elevators and escalators, devices related to electric power, and equipment used in finance-related fields. Do not use Product for Unintended Use unless specifically permitted in this document.
- Do not disassemble, analyze, reverse-engineer, alter, modify, translate or copy Product, whether in whole or in part.
- Product shall not be used for or incorporated into any products or systems whose manufacture, use, or sale is prohibited under any applicable laws or regulations.
- The information contained herein is presented only as guidance for Product use. No responsibility is assumed by TOSHIBA for any infringement of patents or any other intellectual property rights of third parties that may result from the use of Product. No license to any intellectual property right is granted by this document, whether express or implied, by estoppel or otherwise.
- **ABSENT A WRITTEN SIGNED AGREEMENT, EXCEPT AS PROVIDED IN THE RELEVANT TERMS AND CONDITIONS OF SALE FOR PRODUCT, AND TO THE MAXIMUM EXTENT ALLOWABLE BY LAW, TOSHIBA (1) ASSUMES NO LIABILITY WHATSOEVER, INCLUDING WITHOUT LIMITATION, INDIRECT, CONSEQUENTIAL, SPECIAL, OR INCIDENTAL DAMAGES OR LOSS, INCLUDING WITHOUT LIMITATION, LOSS OF PROFITS, LOSS OF OPPORTUNITIES, BUSINESS INTERRUPTION AND LOSS OF DATA, AND (2) DISCLAIMS ANY AND ALL EXPRESS OR IMPLIED WARRANTIES AND CONDITIONS RELATED TO SALE, USE OF PRODUCT, OR INFORMATION, INCLUDING WARRANTIES OR CONDITIONS OF MERCHANTABILITY, FITNESS FOR A PARTICULAR PURPOSE, ACCURACY OF INFORMATION, OR NONINFRINGEMENT.**
- Do not use or otherwise make available Product or related software or technology for any military purposes, including without limitation, for the design, development, use, stockpiling or manufacturing of nuclear, chemical, or biological weapons or missile technology products (mass destruction weapons). Product and related software and technology may be controlled under the Japanese Foreign Exchange and Foreign Trade Law and the U.S. Export Administration Regulations. Export and re-export of Product or related software or technology are strictly prohibited except in compliance with all applicable export laws and regulations.
- Please contact your TOSHIBA sales representative for details as to environmental matters such as the RoHS compatibility of Product. Please use Product in compliance with all applicable laws and regulations that regulate the inclusion or use of controlled substances, including without limitation, the EU RoHS Directive. TOSHIBA assumes no liability for damages or losses occurring as a result of noncompliance with applicable laws and regulations.