

TOSHIBA CMOS Digital Integrated Circuit Silicon Monolithic

# TC7MP245FK, TC7MP245FTG

## Low-Voltage/Low-Power Octal Bus Transceiver with Bus-hold

The TC7MP245 is a high-performance CMOS octal bus transceiver. By a low power consumption circuit, power consumption has been reduced when a bus terminal is disable state ( $\overline{OE}$ =High).

The direction of data transmission is determined by the level of the DIR input. The  $\overline{OE}$  input can be used to disable the device so that the busses are effectively isolated.

But, bus of a B bus side at floating state is maintained in an appropriate logic level due to a bus hold circuit to a B bus. Moreover, the bus-hold circuit which is added to a B bus is off when  $\overline{OE}$  is low.

All inputs are equipped with protection circuits against static discharge.

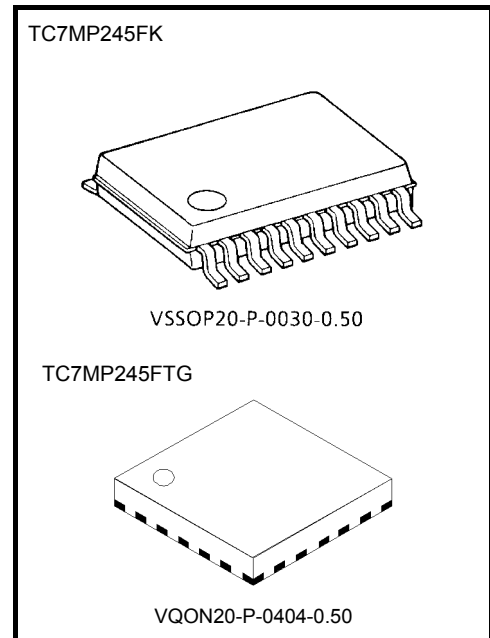

Weight:  
 VSSOP20-P-0030-0.50 : 0.03 g (typ.)  
 VQON20-P-0404-0.50 : 0.0145 g (typ.)

### Features

- Low-voltage operation :  $V_{CC} = 1.65$  to  $3.6$  V
- Low power current consumption : By a new input circuit, power consumption in  $\overline{OE}$ =H is reduced largely.  
 It is most suitable for battery drive products such as personal digital assistant or a cellular phone.
- Quiescent supply current :  $I_{CC} = 5 \mu\text{A}$  (max) ( $V_{CC}$ =3.6V)
- High-speed operation :  $t_{pd} = 3.0$  ns (max) ( $V_{CC}$ =3.3±0.3V)  
 $t_{pd} = 4.6$  ns (max) ( $V_{CC}$ =2.5±0.2V)  
 $t_{pd} = 10.0$  ns (max) ( $V_{CC}$ =1.8±0.15V)
- Output current :  $I_{OHA}/I_{OLA}$  (A bus) = ±12mA (min) ( $V_{CC}$ =3.0V)  
 $I_{OHB}/I_{OLB}$  (B bus) = ±24mA (min) ( $V_{CC}$ =3.0V)
- Latch-up performance : ±300mA
- ESD performance : Machine model ≥ ±200 V  
 Human body model ≥ ±2000 V
- Ultra-small package : VSSOP(US20), VQON20
- Bus hold circuit is built in only the B bus side.(Only in  $\overline{OE}$ =H, a former state is maintained.)
- Floating of A-bus and B-bus are permitted.(When  $\overline{OE}$ =H)
- Gate IC for control(TC7MP01FK) of DIR and  $\overline{OE}$  terminal are prepared.
- 3.6V tolerant function provided on A-bus terminal, DIR and  $\overline{OE}$  terminal.

Note 1: At the time bus terminal is enable state, please do not give a signal from the outside.

Note 2: When mounting VQON package, the type of recommended flux is RA or RMA.

## Pin Assignment (top view)

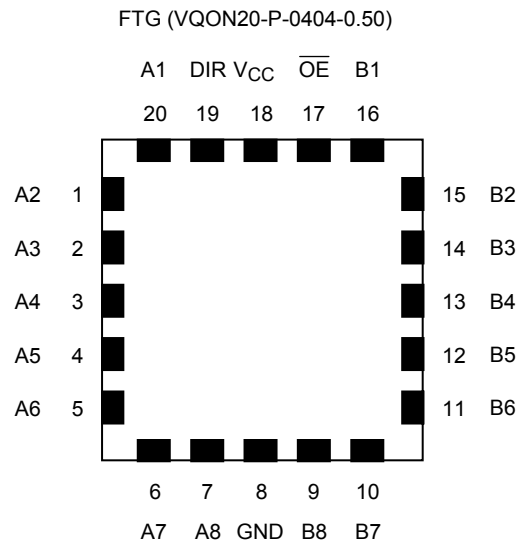
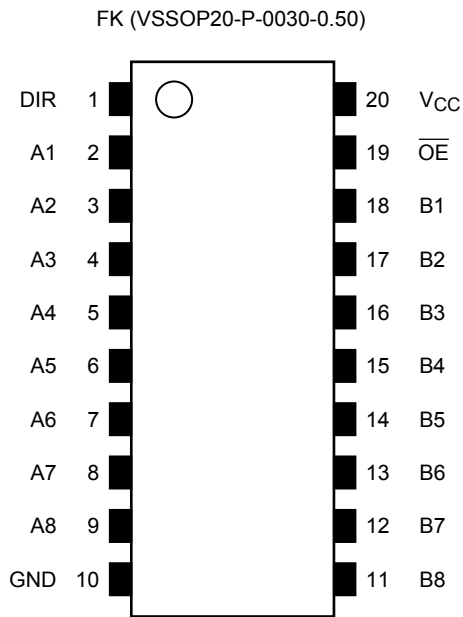

## Truth Table

| Input |                 | Bus state | Bus hold circuit<br>(B bus) |
|-------|-----------------|-----------|-----------------------------|
| DIR   | $\overline{OE}$ |           |                             |
| L     | L               | B→A(B=A)  | OFF                         |
| H     | L               | A→B(A=B)  | OFF                         |
| X     | H               | Z         | ON*                         |

X: Don't care

Z: High impedance

\*: Logic state just before becoming disable is maintained.

Note: When a bus input is in "H" state, and an output is switched to "enable" to "disable", Glitch such as "L" state during about 1 to 3ns occurs in an output. It is not generated when a bus input is in "L" state.

## Marking

FTG (VQON20-P-0404-0.50)

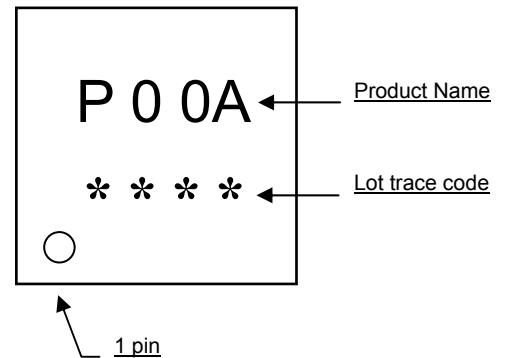

## System Diagram

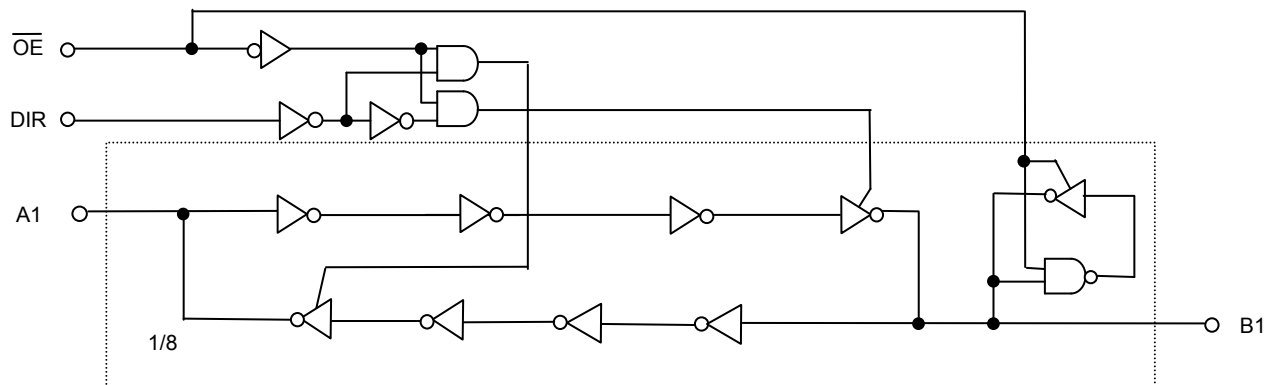

## Absolute Maximum Ratings (Note 1)

| Parameter                                  | Symbol                            | Rating                                | Unit |
|--|-----------------------------------|---------------------------------------|------|
| Power supply voltage                       | V <sub>CC</sub>                   | -0.5 to 4.6                           | V    |
| DC input voltage (DIR, $\overline{OE}$ )   | V <sub>IN</sub>                   | -0.5 to 4.6                           | V    |
| DC input/output voltage(A bus)             | VI/OA                             | -0.5 to 4.6 (Note 2)                  | V    |
|  |                                   | -0.5 to V <sub>CC</sub> +0.5 (Note 3) |      |
| DC input/output voltage(B bus)             | VI/OB                             | -0.5 to V <sub>CC</sub> +0.5          | V    |
| Input diode current(DIR, $\overline{OE}$ ) | I <sub>IHK</sub>                  | -50                                   | mA   |
| Input/Output diode current                 | I <sub>I/OK</sub>                 | ±50                                   | mA   |
| Output current                             | I <sub>OUT</sub>                  | ±50                                   | mA   |
| DC VCC/ground current                      | I <sub>CC</sub> /I <sub>GND</sub> | ±100                                  | mA   |
| Power dissipation                          | P <sub>D</sub>                    | 180                                   | mW   |
| Storage temperature                        | T <sub>stg</sub>                  | -65 to 150                            | °C   |

Note 1: Exceeding any of the absolute maximum ratings, even briefly, lead to deterioration in IC performance or even destruction.

Using continuously under heavy loads (e.g. the application of high temperature/current/voltage and the significant change in temperature, etc.) may cause this product to decrease in the reliability significantly even if the operating conditions (i.e. operating temperature/current/voltage, etc.) are within the absolute maximum ratings and the operating ranges.

Please design the appropriate reliability upon reviewing the Toshiba Semiconductor Reliability Handbook ("Handling Precautions"/"Derating Concept and Methods") and individual reliability data (i.e. reliability test report and estimated failure rate, etc).

Note 2: V<sub>CC</sub>=0V, or output off state.

Note 3:  $\overline{OE}$ ="L", DIR="L"

## Operating Ranges (Note 1)

| Parameter                                | Symbol                             | Rating                        | Unit |
|--|------------------------------------|-------------------------------|------|
| Power supply voltage                     | V <sub>CC</sub>                    | 1.65 to 3.6                   | V    |
|  |                                    | 1.2 to 3.6 (Note 2)           |      |
| DC input voltage (DIR, $\overline{OE}$ ) | V <sub>IN</sub>                    | -0.3 to 3.6                   | V    |
| DC input/output voltage(A bus)           | VI/OA                              | 0 to 3.6 (Note 3)             | V    |
|  |                                    | 0 to V <sub>CC</sub> (Note 4) |      |
| DC input/output voltage(B bus)           | VI/OB                              | 0 to V <sub>CC</sub>          | V    |
| Output current (A bus)                   | I <sub>OHA</sub> /I <sub>OLA</sub> | ±12 (Note 5)                  | mA   |
|  |                                    | ±9 (Note 6)                   |      |
|  |                                    | ±2 (Note 7)                   |      |
| Output current(B bus)                    | I <sub>OHB</sub> /I <sub>OLB</sub> | ±24 (Note 5)                  | mA   |
|  |                                    | ±18 (Note 6)                  |      |
|  |                                    | ±4 (Note 7)                   |      |
| Operating temperature                    | T <sub>opr</sub>                   | -40 to 85                     | °C   |
| Input rise and fall time                 | dt/dv                              | 0 to 10 (Note 8)              | ns/V |

Note 1: The operating ranges must be maintained to ensure the normal operation of the device. Unused inputs and bus inputs must be tied to either V<sub>CC</sub> or GND. Please connect both bus inputs and the bus outputs with V<sub>CC</sub> or GND when the I/O of the bus terminal changes by the function. In this case, please note that the output is not short-circuited.

Note 2: Data retention only

Note 3: V<sub>CC</sub>=0V, or output off state

Note 4:  $\overline{OE}$ ="L", DIR="L"

Note 5: V<sub>CC</sub>=3.0 to 3.6V

Note 6: V<sub>CC</sub>=2.3 to 2.7V

Note 7: V<sub>CC</sub>=1.65 to 1.95V

Note 8: V<sub>IN</sub>=0.8 to 2.0V, V<sub>CC</sub>=3.0V

## Electrical Characteristics

### DC Characteristics (Ta=-40 to 85°C, 2.7V<V<sub>CC</sub>≤3.6V)

| Parameter  |                  | Symbol   | Test Condition  | V <sub>CC</sub> (V)      | Min        | Max                  | Unit |   |
|--|------------------|--|---|--------------------------|------------|----------------------|------|---|
| DC input voltage                                 | H-level          | V <sub>IH</sub>  | -   | 2.7 to 3.6               | 2.0        | -                    | V    |   |
|  | L-level          | V <sub>IL</sub>  | -   | 2.7 to 3.6               | -          | 0.8                  |      |   |
| Output voltage<br>(A bus)                        | H-level          | V <sub>OHA</sub>   | V <sub>IN</sub> = V <sub>IH</sub>                       | I <sub>OHA</sub> =-100uA | 2.7 to 3.6 | V <sub>CC</sub> -0.2 | -    | V |
|  |                  |  |   | I <sub>OH</sub> =-6mA    | 2.7        | 2.2                  | -    |   |
|  |                  |  |   | I <sub>OH</sub> =-9mA    | 3.0        | 2.4                  | -    |   |
|  |                  |  |   | I <sub>OH</sub> =-12mA   | 3.0        | 2.2                  | -    |   |
|  | L-level          | V <sub>OLA</sub>   | V <sub>IN</sub> = V <sub>IL</sub>                       | I <sub>OLA</sub> =100uA  | 2.7 to 3.6 | -                    | 0.2  |   |
|  |                  |  |   | I <sub>OL</sub> =6mA     | 2.7        | -                    | 0.4  |   |
|  |                  |  |   | I <sub>OL</sub> =9mA     | 3.0        | -                    | 0.4  |   |
|  |                  |  |   | I <sub>OL</sub> =12mA    | 3.0        | -                    | 0.55 |   |
| Output voltage<br>(B bus)                        | H-level          | V <sub>OHB</sub>   | V <sub>IN</sub> = V <sub>IH</sub>                       | I <sub>OHB</sub> =-100uA | 2.7 to 3.6 | V <sub>CC</sub> -0.2 | -    | V |
|  |                  |  |   | I <sub>OH</sub> =-12mA   | 2.7        | 2.2                  | -    |   |
|  |                  |  |   | I <sub>OH</sub> =-18mA   | 3.0        | 2.4                  | -    |   |
|  |                  |  |   | I <sub>OH</sub> =-24mA   | 3.0        | 2.2                  | -    |   |
|  | L-level          | V <sub>OLB</sub>   | V <sub>IN</sub> = V <sub>IL</sub>                       | I <sub>OLB</sub> =100uA  | 2.7 to 3.6 | -                    | 0.2  |   |
|  |                  |  |   | I <sub>OLB</sub> =12mA   | 2.7        | -                    | 0.4  |   |
|  |                  |  |   | I <sub>OLB</sub> =18mA   | 3.0        | -                    | 0.4  |   |
|  |                  |  |   | I <sub>OLB</sub> =24mA   | 3.0        | -                    | 0.55 |   |
| Input leakage current(DIR,/OE)                   |                  | I <sub>IN</sub>  | V <sub>IN</sub> = 0 to 3.6 V                            | 2.7 to 3.6               | -          | ±5.0                 | μA   |   |
| Power off leakage current                        |                  | I <sub>OFF</sub>   | A,DIR,/OE= 0 to 3.6 V                                   | 0                        | -          | 5.0                  | μA   |   |
| 3-state output off-state current                 | I <sub>OZA</sub> | V <sub>INA</sub> = V <sub>IH</sub> or V <sub>IL</sub><br>V <sub>out</sub> = 0 to 3.6V            | 2.7 to 3.6  | -                        | ±5.0       | μA                   |      |   |
|  | I <sub>OZB</sub> | V <sub>INB</sub> = V <sub>IH</sub> or V <sub>IL</sub><br>V <sub>out</sub> = 0 or V <sub>CC</sub> | 2.7 to 3.6  | -                        | ±5.0       | μA                   |      |   |
| Quiescent supply current                         |                  | I <sub>CC</sub>  | V <sub>IN</sub> = V <sub>CC</sub> or GND                | 2.7 to 3.6               | -          | 5.0                  | μA   |   |
| Increase in ICC per input                        |                  | ΔI <sub>CC</sub>   | V <sub>IN</sub> = V <sub>CC</sub> -0.6 V<br>(per input) | 2.7 to 3.6               | -          | 750                  | μA   |   |
| Bushold input minimum drive hold current         |                  | I <sub>IHOLD</sub>   | V <sub>IN</sub> = 0.8 V                                 | 3.0                      | 75         | -                    | μA   |   |
|  |                  |  | V <sub>IN</sub> = 2.0 V                                 |                          | -75        | -                    |      |   |
| Bushold input over-drive current to change state |                  | I <sub>IOD</sub>   | V <sub>IN</sub> = "L"→"H"                               | 3.6                      | -          | 550                  | μA   |   |
|  |                  |  | V <sub>IN</sub> = "H"→"L"                               |                          | -          | -550                 |      |   |

Note: It is a necessary electric current to change the input in "L" or "H".

## DC Characteristics (Ta=-40 to 85°C, 2.3V ≤ V<sub>CC</sub> ≤ 2.7V)

| Parameter   | Symbol             | Test Condition   | V <sub>CC</sub> (V)               | Min                      | Max        | Unit                 |     |   |
|---|--------------------|--|-----------------------------------|--------------------------|------------|----------------------|-----|---|
| DC input voltage  | H-level            | V <sub>IH</sub>  | -                                 | 2.3 to 2.7               | 1.6        | -                    | V   |   |
|   | L-level            | V <sub>IL</sub>  | -                                 | 2.3 to 2.7               | -          | 0.7                  |     |   |
| Output voltage<br>(A bus)                               | H-level            | V <sub>OHA</sub>   | V <sub>IN</sub> = V <sub>IH</sub> | I <sub>OHA</sub> =-100uA | 2.3 to 2.7 | V <sub>CC</sub> -0.2 | -   | V |
|   |                    |  |                                   | I <sub>OHA</sub> =-3mA   | 2.3        | 2.0                  | -   |   |
|   |                    |  |                                   | I <sub>OHA</sub> =-6mA   | 2.3        | 1.8                  | -   |   |
|   |                    |  |                                   | I <sub>OHA</sub> =-9mA   | 2.3        | 1.7                  | -   |   |
|   | L-level            | V <sub>OLA</sub>   | V <sub>IN</sub> = V <sub>IL</sub> | I <sub>OLA</sub> =100uA  | 2.3 to 2.7 | -                    | 0.2 |   |
|   |                    |  |                                   | I <sub>OLA</sub> =6mA    | 2.3        | -                    | 0.4 |   |
| Output voltage<br>(B bus)                               | H-level            | V <sub>OHB</sub>   | V <sub>IN</sub> = V <sub>IH</sub> | I <sub>OHB</sub> =-100uA | 2.3 to 2.7 | V <sub>CC</sub> -0.2 | -   | V |
|   |                    |  |                                   | I <sub>OHB</sub> =-6mA   | 2.3        | 2.0                  | -   |   |
|   |                    |  |                                   | I <sub>OHB</sub> =-12mA  | 2.3        | 1.8                  | -   |   |
|   |                    |  |                                   | I <sub>OHB</sub> =-18mA  | 2.3        | 1.7                  | -   |   |
|   | L-level            | V <sub>OLB</sub>   | V <sub>IN</sub> = V <sub>IL</sub> | I <sub>OLB</sub> =100uA  | 2.3 to 2.7 | -                    | 0.2 |   |
|   |                    |  |                                   | I <sub>OLB</sub> =12mA   | 2.3        | -                    | 0.4 |   |
| L-level   | V <sub>OLB</sub>   | V <sub>IN</sub> = V <sub>IL</sub>  | I <sub>OLB</sub> =18mA            | 2.3                      | -          | 0.6                  |     |   |
|   |                    |  |                                   |                          |            |                      |     |   |
| Input leakage current(DIR,/OE)                          | I <sub>IN</sub>    | V <sub>IN</sub> = 0 to 3.6 V   | 2.3 to 2.7                        | -                        | ±5.0       | μA                   |     |   |
| Power off leakage current                               | I <sub>OFF</sub>   | A,DIR,/OE=0 to 3.6 V   | 0                                 | -                        | 5.0        | μA                   |     |   |
| 3-state output off-state current                        | I <sub>OZA</sub>   | V <sub>INA</sub> =V <sub>IH</sub> or V <sub>IL</sub><br>V <sub>out</sub> =0 to 3.6V            | 2.3 to 2.7                        | -                        | ±5.0       | μA                   |     |   |
|   | I <sub>OZB</sub>   | V <sub>INB</sub> =V <sub>IH</sub> or V <sub>IL</sub><br>V <sub>out</sub> =0 or V <sub>CC</sub> | 2.3 to 2.7                        | -                        | ±5.0       | μA                   |     |   |
| Quiescent supply current                                | I <sub>CC</sub>    | V <sub>IN</sub> =V <sub>CC</sub> or GND  | 2.3 to 2.7                        | -                        | 5.0        | μA                   |     |   |
| Bushold input minimum drive hold current                | I <sub>IHOLD</sub> | V <sub>IN</sub> = 0.7 V  | 2.3                               | 45                       | -          | μA                   |     |   |
|   |                    | V <sub>IN</sub> = 1.6 V  |                                   | -45                      | -          |                      |     |   |
| Bushold input over-drive current to change state (Note) | I <sub>IOD</sub>   | V <sub>IN</sub> = "L" → "H"  | 2.7                               | -                        | 400        | μA                   |     |   |
|   |                    | V <sub>IN</sub> = "H" → "L"  |                                   | -                        | -400       |                      |     |   |

Note: It is a necessary electric current to change the input in "L" or "H".

## DC Characteristics (Ta=-40 to 85°C, 1.65V ≤ V<sub>CC</sub> < 2.3V)

| Parameter   | Symbol               | Test Condition   | V <sub>CC</sub> (V)               | Min                      | Max                  | Unit                 |     |   |
|---|----------------------|--|-----------------------------------|--------------------------|----------------------|----------------------|-----|---|
| DC input voltage  | H-level              | V <sub>IH</sub>  | -                                 | 1.65 to 2.3              | V <sub>CC</sub> ×0.7 | -                    | V   |   |
|   | L-level              | V <sub>IL</sub>  | -                                 | 1.65 to 2.3              | -                    | V <sub>CC</sub> ×0.2 |     |   |
| Output voltage<br>(A bus)                                     | H-level              | V <sub>OHA</sub>   | V <sub>IN</sub> = V <sub>IH</sub> | I <sub>OHA</sub> =-100μA | 1.65                 | V <sub>CC</sub> -0.2 | -   | V |
|   |                      |  |                                   | I <sub>OHA</sub> =-2mA   | 1.65                 | 1.3                  | -   |   |
|   | L-level              | V <sub>OLA</sub>   | V <sub>IN</sub> = V <sub>IL</sub> | I <sub>OLA</sub> =2mA    | 1.65                 | -                    | 0.2 |   |
| Output voltage<br>(B bus)                                     | H-level              | V <sub>OHB</sub>   | V <sub>IN</sub> = V <sub>IH</sub> | I <sub>OHB</sub> =-100μA | 1.65                 | V <sub>CC</sub> -0.2 | -   | V |
|   |                      |  |                                   | I <sub>OHB</sub> =-4mA   | 1.65                 | 1.3                  | -   |   |
|   | L-level              | V <sub>OLB</sub>   | V <sub>IN</sub> = V <sub>IL</sub> | I <sub>OLB</sub> =4mA    | 1.65                 | -                    | 0.2 |   |
| Input leakage current(DIR,/OE)                                | I <sub>IN</sub>      | V <sub>IN</sub> =0 to 3.6 V  | 1.65 to 2.3                       | -                        | ±5.0                 | μA                   |     |   |
| Power off leakage current                                     | I <sub>OFF</sub>     | A,DIR,/OE=0 to 3.6 V   | 0                                 | -                        | 5.0                  | μA                   |     |   |
| 3-state output off-state current                              | I <sub>OZA</sub>     | V <sub>INA</sub> =V <sub>IH</sub> or V <sub>IL</sub><br>V <sub>out</sub> =0 to 3.6 V           | 1.65 to 2.3                       | -                        | ±5.0                 | μA                   |     |   |
|   | I <sub>OZB</sub>     | V <sub>INB</sub> =V <sub>IH</sub> or V <sub>IL</sub><br>V <sub>out</sub> =0 or V <sub>CC</sub> | 1.65 to 2.3                       | -                        | ±5.0                 | μA                   |     |   |
| Quiescent supply current                                      | I <sub>CC</sub>      | V <sub>IN</sub> =V <sub>CC</sub> or GND  | 1.65 to 2.3                       | -                        | 5.0                  | μA                   |     |   |
| Bushold input minimum drive<br>hold current                   | I <sub>I(HOLD)</sub> | V <sub>IN</sub> =0.33 V  | 1.65                              | 20                       | -                    | μA                   |     |   |
|   |                      | V <sub>IN</sub> =1.16 V  |                                   | -20                      | -                    |                      |     |   |
| Bushold input over-drive current<br>to change state<br>(Note) | I <sub>I(OD)</sub>   | V <sub>IN</sub> = "L"→"H"  | 1.95                              | -                        | 300                  | μA                   |     |   |
|   |                      | V <sub>IN</sub> = "H"→"L"  |                                   | -                        | -300                 |                      |     |   |

Note: It is a necessary electric current to change the input in "L" or "H".

## AC Characteristics (Ta=-40 to 85°C, Input: $t_r = t_f = 2.0 \text{ ns}$ , $C_L = 30 \text{ pF}$ , $R_L = 500 \Omega$ )

| Parameter                   | Symbol                   | Test Condition     | V <sub>CC</sub> (V) | Min | Max  | Unit |
|-----------------------------|--------------------------|--------------------|---------------------|-----|------|------|
| Propagation delay time      | $t_{pLH}$<br>$t_{pHL}$   | Figure 1, Figure 2 | 1.8±0.15            | 1.0 | 10.0 | ns   |
|                             |                          |                    | 2.5±0.2             | 0.8 | 4.6  |      |
|                             |                          |                    | 3.3±0.3             | 0.6 | 3.0  |      |
| 3-state output enable time  | $t_{pZL}$<br>$t_{pZH}$   | Figure 1, Figure 3 | 1.8±0.15            | 1.0 | 15.0 | ns   |
|                             |                          |                    | 2.5±0.2             | 0.8 | 7.8  |      |
|                             |                          |                    | 3.3±0.3             | 0.6 | 5.6  |      |
| 3-state output disable time | $t_{pLZ}$<br>$t_{pHZ}$   | Figure 1, Figure 3 | 1.8±0.15            | 1.0 | 6.5  | ns   |
|                             |                          |                    | 2.5±0.2             | 0.8 | 4.3  |      |
|                             |                          |                    | 3.3±0.3             | 0.6 | 3.9  |      |
| Output to output skew       | $t_{osLH}$<br>$t_{osHL}$ | (Note)             | 1.8±0.15            | -   | 0.5  | ns   |
|                             |                          |                    | 2.5±0.2             | -   | 0.5  |      |
|                             |                          |                    | 3.3±0.3             | -   | 0.5  |      |

For  $C_L=50\text{pF}$ , add approximately 300ps to the AC maximum specification.

Note: Parameter guaranteed by design.

$$(t_{osLH} = |t_{pLHm} - t_{pLHn}|, t_{osHL} = |t_{pHLm} - t_{pHLn}|)$$

## Capacitive Characteristics (Ta=25°C)

| Characteristics                                | Symbol    | Test Condition   | V <sub>CC</sub> (V) | Typ. | Unit |
|--|-----------|--|---------------------|------|------|
| Input capacitance                              | $C_{IN}$  |  | 1.8,2.5,3.3         | 6    | pF   |
| Bus I/O capacitance                            | $C_{I/O}$ |  | 1.8,2.5,3.3         | 7    | pF   |
| Power dissipation capacitance<br>(A bus input) | $C_{PDA}$ | $\overline{OE} = \text{"L"} , finA=100\text{MHz}$ Table 1 (Note) | 1.8,2.5,3.3         | 20   | pF   |
|  |           | $\overline{OE} = \text{"H"} , finA=100\text{MHz}$ Table 1 (Note) |                     | 0    | pF   |
| Power dissipation capacitance<br>(B bus input) | $C_{PDB}$ | $\overline{OE} = \text{"L"} , finB=100\text{MHz}$ Table 1 (Note) | 1.8,2.5,3.3         | 16   | pF   |
|  |           | $\overline{OE} = \text{"H"} , finB=100\text{MHz}$ Table 1 (Note) |                     | 1    | pF   |

Note:  $C_{PD}$  is defined as the value of the internal equivalent capacitance which is calculated from the operating current consumption without load.

Average operating current can be obtained by the equation.

$$I_{CC(opr)} = C_{PD} \cdot V_{CC} \cdot V_{IN} + I_{CC}/8(\text{per bit})$$

Table1 CPD Test Condition

| Function   | Pin |   |   |   |   |   |   |   |   |    |    |    |    |    |    |    |    |    |    |    |
|------------|-----|---|---|---|---|---|---|---|---|----|----|----|----|----|----|----|----|----|----|----|
|            | 1   | 2 | 3 | 4 | 5 | 6 | 7 | 8 | 9 | 10 | 11 | 12 | 13 | 14 | 15 | 16 | 17 | 18 | 19 | 20 |
| A bus /OE= | H   | P | X | X | X | X | X | X | X | G  | O  | O  | O  | O  | O  | O  | O  | C  | L  | V  |
| A bus /OE= | H   | P | O | O | O | O | O | O | O | G  | O  | O  | O  | O  | O  | O  | O  | O  | H  | V  |
| B bus /OE= | L   | C | O | O | O | O | O | O | O | G  | X  | X  | X  | X  | X  | X  | X  | P  | L  | V  |
| B bus /OE= | L   | O | O | O | O | O | O | O | O | G  | O  | O  | O  | O  | O  | O  | O  | P  | H  | V  |

Symbol explanation-

- V = V<sub>CC</sub>(+3.3V)
- G = GND (0V)
- H = Logic 1 (V<sub>CC</sub>)
- L = Logic 0 (GND)
- X = Don't care(Fixed to V<sub>CC</sub> or GND)
- O = Open
- C = Connect a condenser(30pF) between output terminal and GND.
- P = Input pulse with 50% duty cycle.

### AC Test Circuit

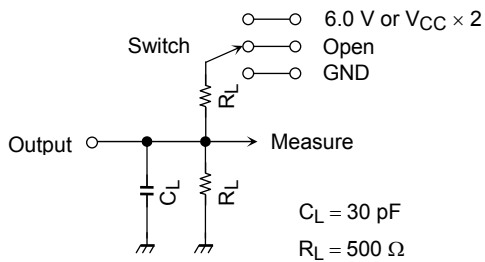

| Parameter                           | Switch  |
|-------------------------------------|---|
| t <sub>pLH</sub> , t <sub>pHL</sub> | Open  |
| t <sub>pLZ</sub> , t <sub>pZL</sub> | 6.0 V @V <sub>CC</sub> = 3.3 ± 0.3 V<br>V <sub>CC</sub> × 2 @V <sub>CC</sub> = 2.5 ± 0.2 V<br>@V <sub>CC</sub> = 1.8 ± 0.15 V |
| t <sub>pHZ</sub> , t <sub>pZH</sub> | GND   |

Figure 1

### AC Waveform

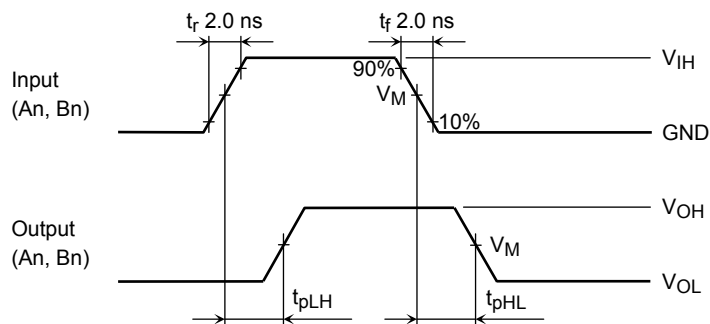
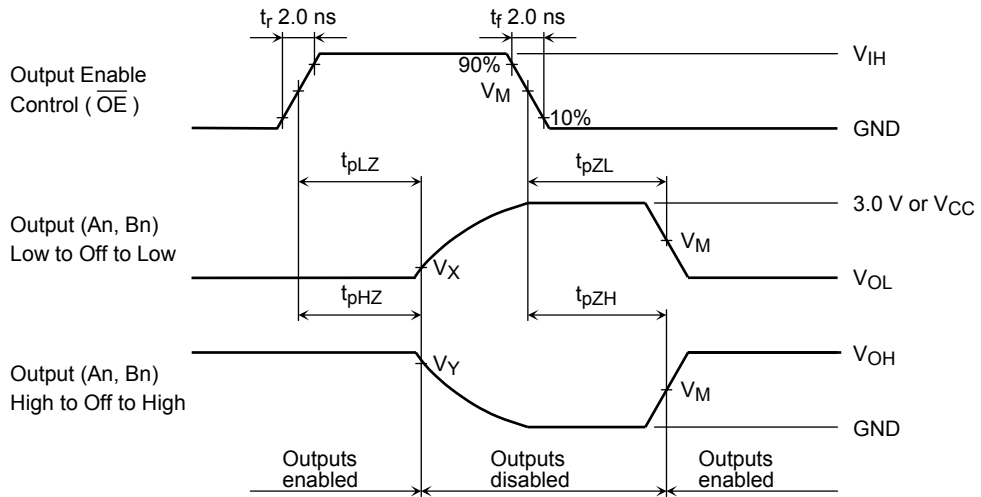

Figure 2 t<sub>pLH</sub>, t<sub>pHL</sub>



**Figure 3**  $t_{pLZ}$ ,  $t_{pHZ}$ ,  $t_{pZL}$ ,  $t_{pZH}$

| Symbol   | $V_{CC}$                 |                           |                           |
|----------|--------------------------|---------------------------|---------------------------|
|          | $3.3 \pm 0.3 \text{ V}$  | $2.5 \pm 0.2 \text{ V}$   | $1.8 \pm 0.15 \text{ V}$  |
| $V_{IH}$ | 2.7 V                    | $V_{CC}$                  | $V_{CC}$                  |
| $V_M$    | 1.5 V                    | $V_{CC}/2$                | $V_{CC}/2$                |
| $V_X$    | $V_{OL} + 0.3 \text{ V}$ | $V_{OL} + 0.15 \text{ V}$ | $V_{OL} + 0.15 \text{ V}$ |
| $V_Y$    | $V_{OH} - 0.3 \text{ V}$ | $V_{OH} - 0.15 \text{ V}$ | $V_{OH} - 0.15 \text{ V}$ |

## Package Dimensions

VSSOP20-P-0030-0.50

Unit : mm

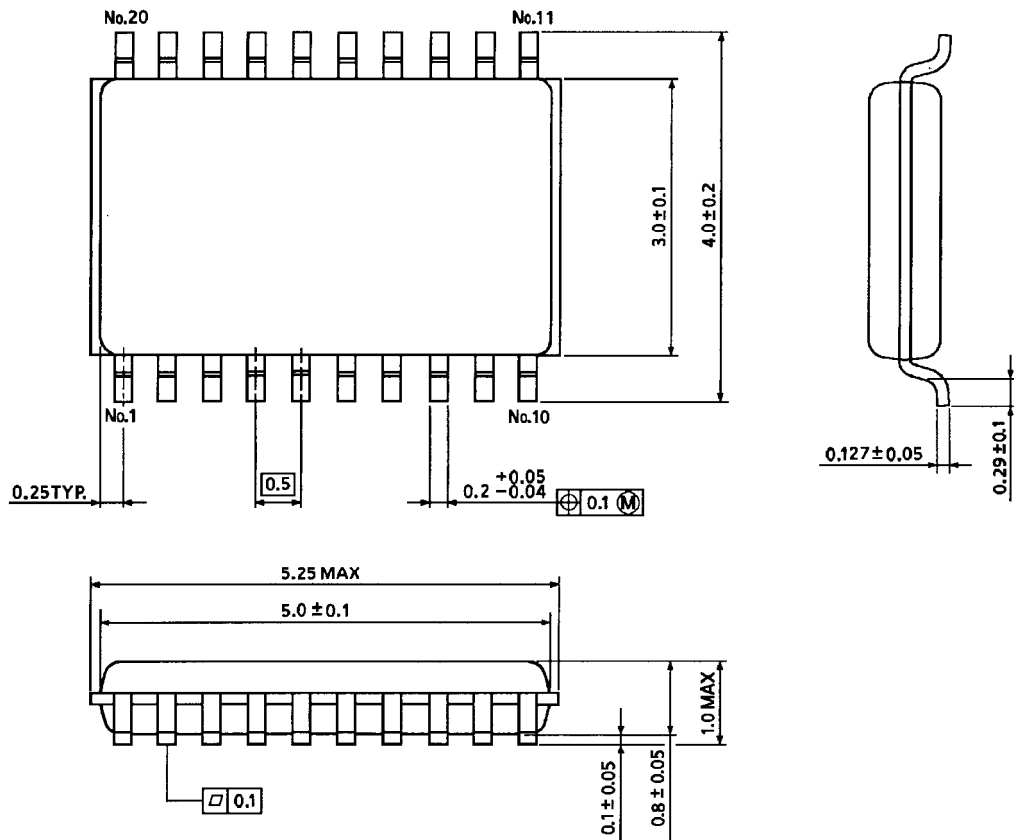

Weight: 0.03 g (typ.)

Package Dimensions

Unit : mm

VQON20-P-0404-0.5

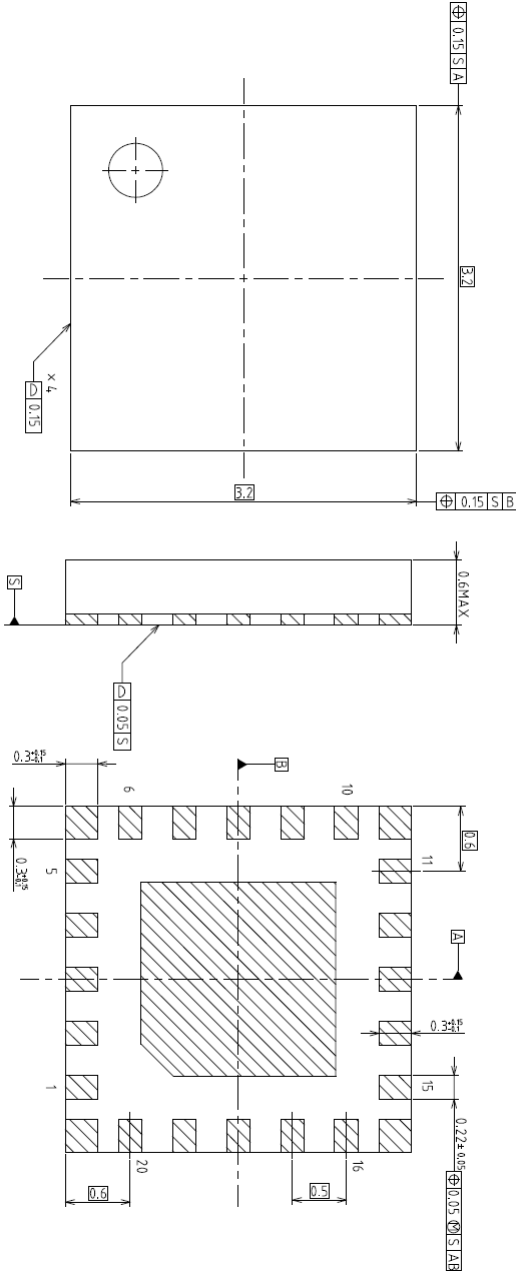

Weight: 0.0145 g (typ.)

**RESTRICTIONS ON PRODUCT USE**

- Toshiba Corporation, and its subsidiaries and affiliates (collectively "TOSHIBA"), reserve the right to make changes to the information in this document, and related hardware, software and systems (collectively "Product") without notice.
- This document and any information herein may not be reproduced without prior written permission from TOSHIBA. Even with TOSHIBA's written permission, reproduction is permissible only if reproduction is without alteration/omission.
- Though TOSHIBA works continually to improve Product's quality and reliability, Product can malfunction or fail. Customers are responsible for complying with safety standards and for providing adequate designs and safeguards for their hardware, software and systems which minimize risk and avoid situations in which a malfunction or failure of Product could cause loss of human life, bodily injury or damage to property, including data loss or corruption. Before creating and producing designs and using, customers must also refer to and comply with (a) the latest versions of all relevant TOSHIBA information, including without limitation, this document, the specifications, the data sheets and application notes for Product and the precautions and conditions set forth in the "TOSHIBA Semiconductor Reliability Handbook" and (b) the instructions for the application that Product will be used with or for. Customers are solely responsible for all aspects of their own product design or applications, including but not limited to (a) determining the appropriateness of the use of this Product in such design or applications; (b) evaluating and determining the applicability of any information contained in this document, or in charts, diagrams, programs, algorithms, sample application circuits, or any other referenced documents; and (c) validating all operating parameters for such designs and applications. **TOSHIBA ASSUMES NO LIABILITY FOR CUSTOMERS' PRODUCT DESIGN OR APPLICATIONS.**
- Product is intended for use in general electronics applications (e.g., computers, personal equipment, office equipment, measuring equipment, industrial robots and home electronics appliances) or for specific applications as expressly stated in this document. Product is neither intended nor warranted for use in equipment or systems that require extraordinarily high levels of quality and/or reliability and/or a malfunction or failure of which may cause loss of human life, bodily injury, serious property damage or serious public impact ("Unintended Use"). Unintended Use includes, without limitation, equipment used in nuclear facilities, equipment used in the aerospace industry, medical equipment, equipment used for automobiles, trains, ships and other transportation, traffic signaling equipment, equipment used to control combustions or explosions, safety devices, elevators and escalators, devices related to electric power, and equipment used in finance-related fields. Do not use Product for Unintended Use unless specifically permitted in this document.
- Do not disassemble, analyze, reverse-engineer, alter, modify, translate or copy Product, whether in whole or in part.
- Product shall not be used for or incorporated into any products or systems whose manufacture, use, or sale is prohibited under any applicable laws or regulations.
- The information contained herein is presented only as guidance for Product use. No responsibility is assumed by TOSHIBA for any infringement of patents or any other intellectual property rights of third parties that may result from the use of Product. No license to any intellectual property right is granted by this document, whether express or implied, by estoppel or otherwise.
- **ABSENT A WRITTEN SIGNED AGREEMENT, EXCEPT AS PROVIDED IN THE RELEVANT TERMS AND CONDITIONS OF SALE FOR PRODUCT, AND TO THE MAXIMUM EXTENT ALLOWABLE BY LAW, TOSHIBA (1) ASSUMES NO LIABILITY WHATSOEVER, INCLUDING WITHOUT LIMITATION, INDIRECT, CONSEQUENTIAL, SPECIAL, OR INCIDENTAL DAMAGES OR LOSS, INCLUDING WITHOUT LIMITATION, LOSS OF PROFITS, LOSS OF OPPORTUNITIES, BUSINESS INTERRUPTION AND LOSS OF DATA, AND (2) DISCLAIMS ANY AND ALL EXPRESS OR IMPLIED WARRANTIES AND CONDITIONS RELATED TO SALE, USE OF PRODUCT, OR INFORMATION, INCLUDING WARRANTIES OR CONDITIONS OF MERCHANTABILITY, FITNESS FOR A PARTICULAR PURPOSE, ACCURACY OF INFORMATION, OR NONINFRINGEMENT.**
- Do not use or otherwise make available Product or related software or technology for any military purposes, including without limitation, for the design, development, use, stockpiling or manufacturing of nuclear, chemical, or biological weapons or missile technology products (mass destruction weapons). Product and related software and technology may be controlled under the Japanese Foreign Exchange and Foreign Trade Law and the U.S. Export Administration Regulations. Export and re-export of Product or related software or technology are strictly prohibited except in compliance with all applicable export laws and regulations.
- Please contact your TOSHIBA sales representative for details as to environmental matters such as the RoHS compatibility of Product. Please use Product in compliance with all applicable laws and regulations that regulate the inclusion or use of controlled substances, including without limitation, the EU RoHS Directive. TOSHIBA assumes no liability for damages or losses occurring as a result of noncompliance with applicable laws and regulations.