

Triple Pole
Standard Environment

Limit Switches

Butt
Contacts

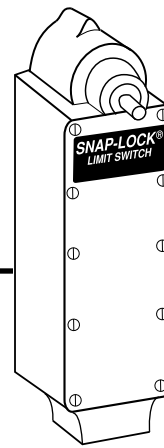

Limit Switches

The versatility of the Snap-Lock mechanism is gained through the use of a series of uniquely designed cams. The cam and cam mechanism allow features such as bi-directional operation and generous overtravel. These features make the EA700 Series one of the most popular. Can be furnished with Standard, Wide or Long mounting.

EA700 Triple Pole 3 N.O. - 3 N.C. / Butt Contacts / Cam Action

Standard Mounting Model No.	Wide Mounting Model No.	Long Mounting Model No.	Dir. Of Operation	Angle A Trip Travel	Angle B Reset Travel	Angle C Recom. Travel	Angle D Total Travel	Angle E Min. Travel to Maintain	Angle F Overall Travel	Torque (inch lbs)	Contact Config.
STANDARD TRAVEL											
EA700-30000	EA700-60000	EA700-90000	CW	18°	14°	30°	90°	-	-	33	A
EA700-30001	EA700-60001	EA700-90001	CCW	18°	14°	30°	90°	-	-	33	B
EA700-30100	EA700-60100	EA700-90100	CW/CCW	18°	14°	30°	90°	-	-	33	C

Common Switch Characteristics

TRIPLE POLE, STANDARD ENVIRONMENT, BUTT CONTACTS	
NEMA Enclosure Type	1, 4, 13
Housing Material	Zinc
Ambient Temperature Range*	-20°C to +90°C
Shipping Weight	5 lbs. approx.
Lever Adjustment	7°30' Increments Thru 360°
Contacts	Butt, Silver Alloy, Form Z

* Some high temperature (+20°C to 180°C) and low temperature (-40°C to +90°C) versions available. Contact factory.

Continuous Current Rating - Amperes

VOLTAGE	AC	DC
125	20.0	5.0
250	15.0	1.5
480	10.0	-
600	5.0	-

75-100% Power Factor

See Operating Levers Section

STANDARD MOUNTING PLATE

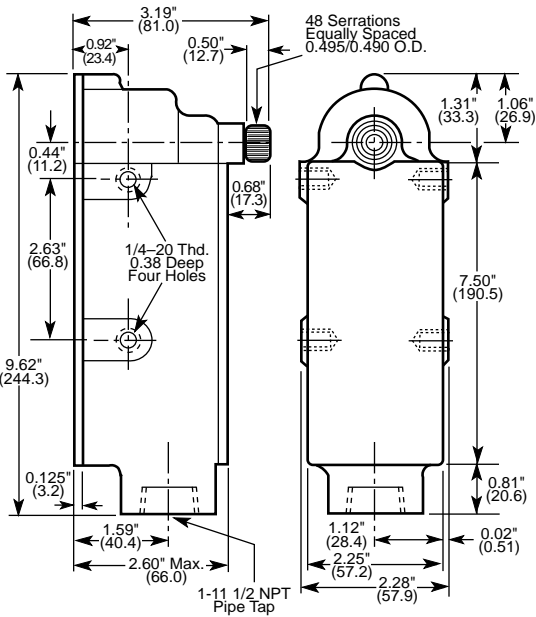

WIDE MOUNTING PLATE

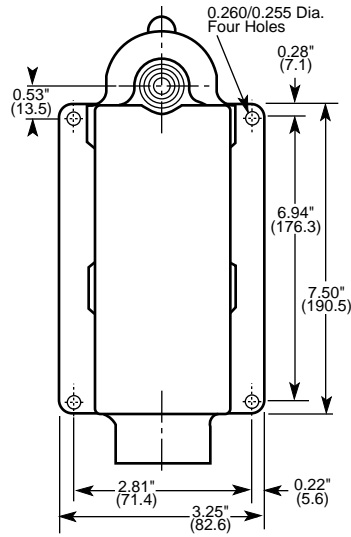

LONG MOUNTING PLATE

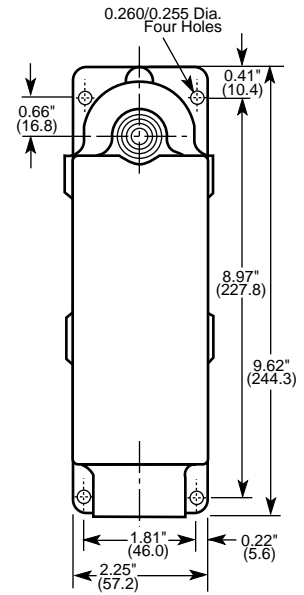

Dimensions: inches/(mm)

Limit Switches

Contact Configurations

CIRCUIT A

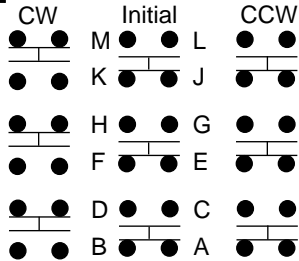

CIRCUIT B

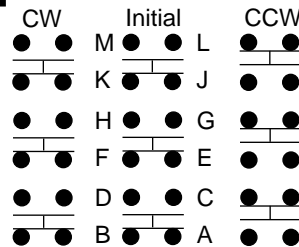

CIRCUIT C

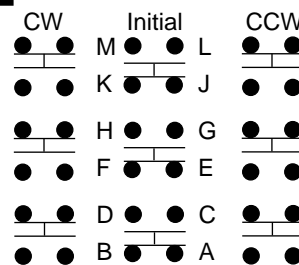

Operational Data Drawings

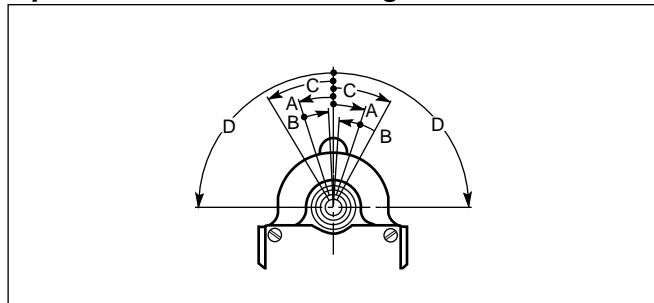

NAMCO

2013 West Meeting Street • Lancaster, SC 29720
 1-803-286-8491 • FAX: 1-800-678-6263
www.namcocontrols.com

For technical assistance, call 1-800-NAMTECH