

Non-Contact Coupling System

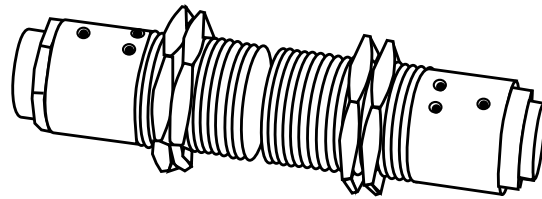

- Provides connector-free installation and operation between stationary and moving assemblies
- Any Namco 2-wire AC/DC low leakage sensor can be used for part sensing on the moving equipment side of the system
- Up to 0.10" gap between Master and Remote Coupler

The Namco ProxCoupler™ System is designed primarily for use on equipment that has both stationary and movable elements. The ProxCoupler replaces cumbersome connector contact or slip-ring assemblies with a non-contact, solid-state system consisting of two parts. The Master Coupler is used on the stationary side of the equipment and provides power to the Remote Coupler. The Remote Coupler supplies power to the Remote Sensor and target status information to the Master Coupler. The Remote Sensor can be either a Namco 2-Wire AC/DC device or a mechanical contact device. Interconnection of the Remote Coupler and Remote Sensor is via standard double-ended Mini-style cordsets.

Applications:

- Material Handling Systems
- Monitoring Robot Arm Applications
- Rotary Transfer Machines
- Transfer Presses

Model No.	Description
EE100-00125	Master Coupler (2-wire DC)
EE970-77600	Master Coupler (3-wire DC, PNP)
EE970-77000	Remote Coupler

Special Application Solutions

Potential Uses of the Prox Coupler System

CONVEYOR APPLICATION

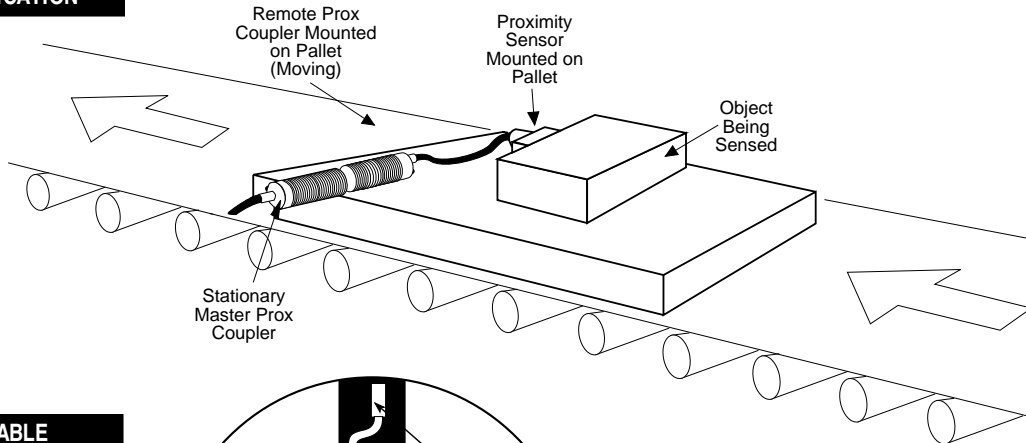

ROTARY INDEX TABLE APPLICATION

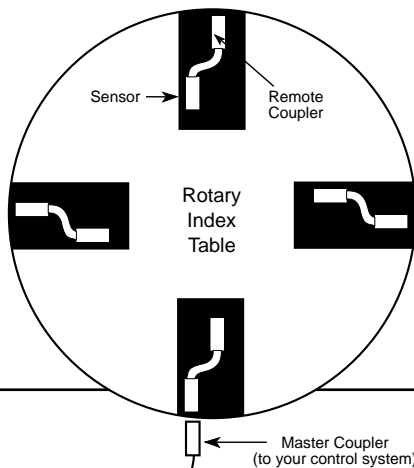

Permits additional sensors without addition of conventional slip rings



Specifications

NON-CONTACT COUPLING SYSTEM		
MASTER COUPLER	3-Wire DC, PNP	2-Wire DC
Supply Voltage	20-30 VDC	
On-State Voltage Drop	+2.5 V	+10 V
Maximum Load	0.2 A	
Minimum Load	N/A	60 mA
Leakage Current	10 μ A	15 mA
WFI/SCP	yes	
Air Gap (minimum)	0.01 inch	
Air Gap (maximum)	0.10 inch	
Lateral Misalignment	0.01 inch (max.)	
Operating Temperature	-20°C to +70°C	
LED Indicators	Red On: Power on/non-conducting Green On: Target sensed/conducting Both Flashing: Short circuit condition	
REMOTE COUPLER		
LED Indicator	Red On: Energized by Master Coupler	
Remote Coupler Connection	3-pin male/female Mini style cordset	

Dimensional Drawings Prox Coupler

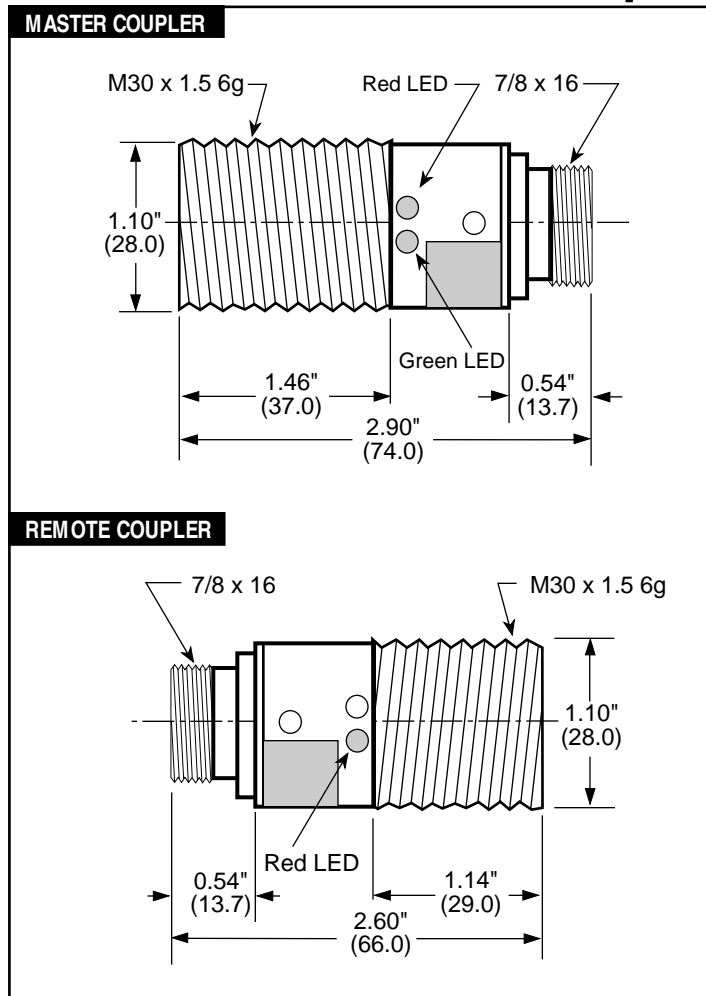

Circuit Drawings

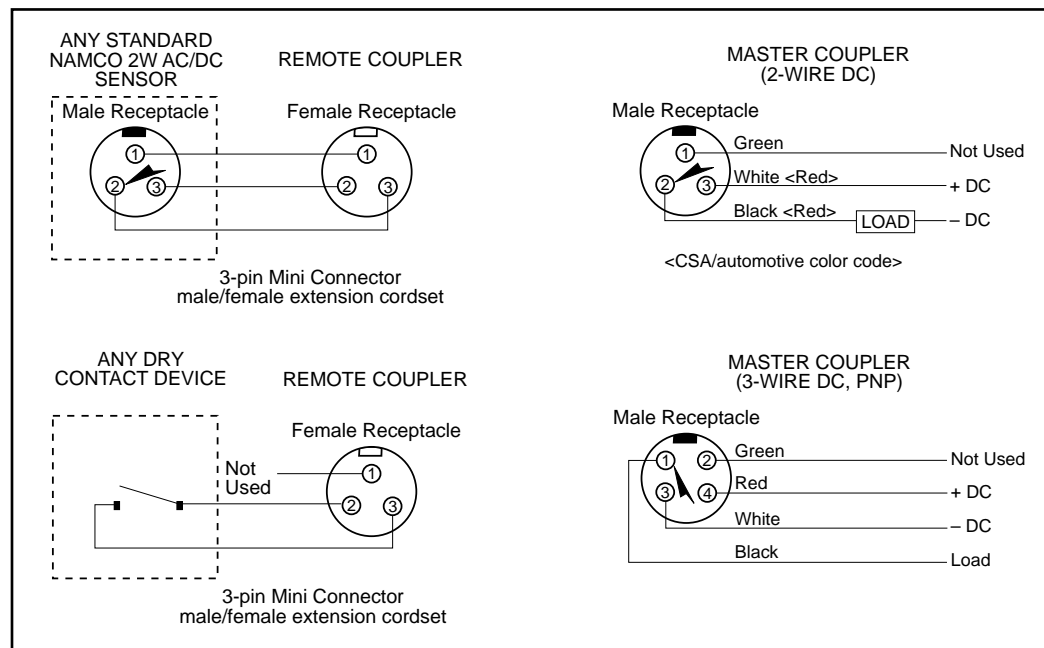

Special Application Solutions

NAMCO

2013 West Meeting Street • Lancaster, SC 29720
 1-803-286-8491 • FAX: 1-800-678-6263
www.namcocontrols.com

For technical assistance, call 1-800-NAMTECH