

## PB-24Q

### MOUNTING BOARD

- Plug-compatible logic connections
- Screw terminal barrier block for load connections
- 5 amp field-replaceable fuses (LITTLEFUSE #251005 or equivalent)
- All even-numbered logic connections are logic ground
- Input and output modules accepted interchangeably
- Operate with 5, 15 or 24 volt logic supplies
- Captive-screw retaining system for Quad-Pack modules

### MECHANICAL SPECIFICATIONS

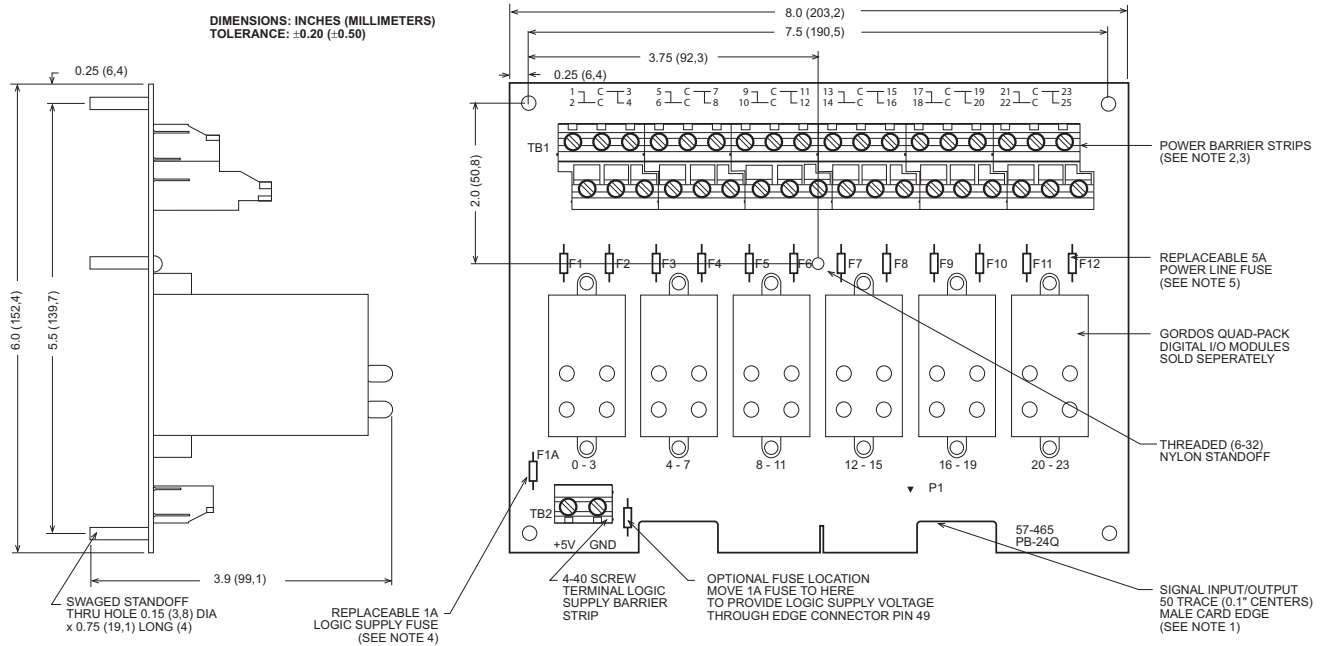

- NOTES:
- MATING CONNECTOR IS BERG 66317-150 OR EQUIVALENT. SPECIFY SUFFIX "C" FOR OPTIONAL BERG 65823-093 (OR EQUIVALENT) MALE PIN CONNECTOR FOR PARALLEL-TO-THE BOARD CABLE CONNECTION. SPECIFY SUFFIX "V" FOR OPTIONAL BERG 65863-145 (OR EQUIVALENT) MALE PIN CONNECTOR FOR PERPENDICULAR-TO-THE-BOARD CABLE CONNECTION.
  - 6-32 SCREW TERMINAL BARRIER STRIPS ACCEPT WIRE SIZES FORM 24 TO 12 AWG.
  - OPTIONAL JUMPERS AVAILABLE TO INTERCONNECT BARRIER STRIP COMMONS. ORDER 2 EACH JUMPER "JQ4".
  - LITTLE FUSE 251001 OR EQUIVALENT.
  - LITTLE FUSE 251005 OR EQUIVALENT.

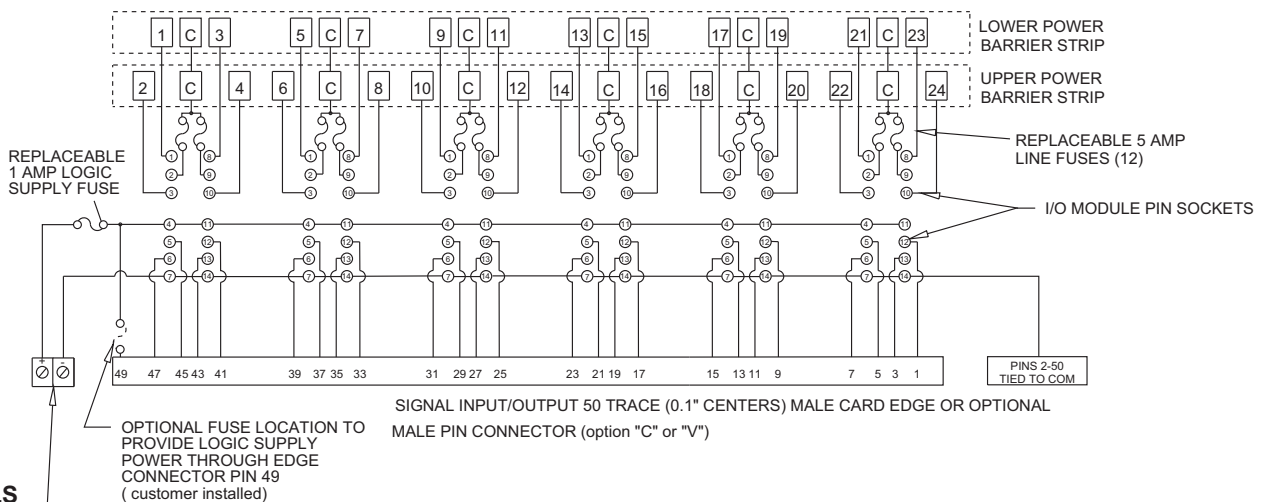

### APPROVALS

UL E79183  
CSA 38595

LOGIC SUPPLY BARRIER STRIP

Rev. 020410

**⚠ DANGER / PELIGRO / DANGER /GEFAHR / PERICOLO / PERIGO**

<p><b>HAZARD OF ELECTRIC SHOCK, EXPLOSION, OR ARC FLASH.</b></p> <ul style="list-style-type: none"> <li>• Disconnect all power before installing or working with this equipment.</li> <li>• Verify all connections and replace all covers before turning on power.</li> </ul> <p><b>Failure to follow these instructions will result in death or serious injury.</b></p>	<p><b>RIESGO DE DESCARGA ELECTRICA O EXPLOSION.</b></p> <ul style="list-style-type: none"> <li>• Desconectar todos los suministros de energia a este equipo antes de trabajar con este equipo.</li> <li>• Verificar todas las conexiones y colocar todas las tapas antes de energizar el equipo.</li> </ul> <p><b>El incumplimiento de estas instrucciones puede provocar la muerte o lesiones serias.</b></p>	<p><b>RISQUE DE DESCARGE ELECTRIQUE OU EXPLOSION</b></p> <ul style="list-style-type: none"> <li>• Eteindre toutes les sources d'énergie de cet appareil avant de travailler dessus de cet appareil</li> <li>• Vérifier tous connections, et remettre tous couverts en place avant de mettre sous</li> </ul> <p><b>De non-suivi de ces instructions provoquera la mort ou des lésions sérieuses.</b></p>	<p><b>GEFAHR EINES ELEKTRISCHE N SCHLAGES ODER EINER EXPLOSION.</b></p> <ul style="list-style-type: none"> <li>• Stellen Sie jeglichen Strom ab, der dieses Gerät versorgt, bevor Sie an dem Gerät Arbeiten durchführen</li> <li>• Vor dem Drehen auf Energie alle Anschlüsse überprüfen und alle Abdeckungen ersetzen.</li> </ul> <p><b>Unterlassung dieser Anweisungen können zum Tode oder zu schweren Verletzungen führen.</b></p>	<p><b>RISCHIO DI SCOSSA ELETTRICA O DELL'ESPLOSIONE.</b></p> <ul style="list-style-type: none"> <li>• Spenga tutta l'alimentazione e che fornisce questa apparecchiatura prima del lavorare a questa apparecchiatura</li> <li>• Verificare tutti i collegamenti e sostituire tutte le coperture prima della rotazione sull'alimentazione</li> </ul> <p><b>L'omissione di seguire queste istruzioni provocherà la morte o di lesioni serie</b></p>	<p><b>RISCO DE DESCARGA ELÉTRICA OU EXPLOÇÃO</b></p> <ul style="list-style-type: none"> <li>• Desconectar o equipamento de toda a energia antes de instalar ou trabalhar com este equipamento</li> <li>• Verificar todas as conexões e recolocar todas as tampas antes de religar o equipamento</li> </ul> <p><b>O não cumprimento destas instruções pode levar à morte ou lesões sérias.</b></p>
--	--	---	--	---	---

## ANNEX - ENVIROMENTAL INFORMATION

The environmental information disclosed in this annex including the EIP Pollution logo are in compliance with People's Republic of China Electronic Industry Standard SJ/T11364 – 2006, Marking for Control of Pollution Caused by Electronic Information Products.

Part Name	Toxic or hazardous Substance and Elements					
	Lead (Pb)	Mercury (Hg)	Cadmium (Cd)	Hexavalent Chromium (Cr (VI))	Polybrominated biphenyls (PBB)	Polybrominated diphenyl ethers (PBDE)
Semiconductor die	○	○	○	○	○	○
Solder	○	○	○	○	○	○

此附件所标示的包括电子信息产品污染图标的环保信息符合中华人民共和国电子行业标准 SJ/T11364 - 2006, 电子信息产品污染控制标识要求



部件名称	有毒有害物质或元素					
	铅 (Pb)	汞 (Hg)	镉 (Cd)	六价铬 (Cr (VI))	多溴联苯 (PBB)	多溴二苯醚 (PBDE)
半导体芯片	○	○	○	○	○	○
焊接点	○	○	○	○	○	○