

Inductive proximity switch

IFBR 17N17T1/S14L-9

dimension drawing

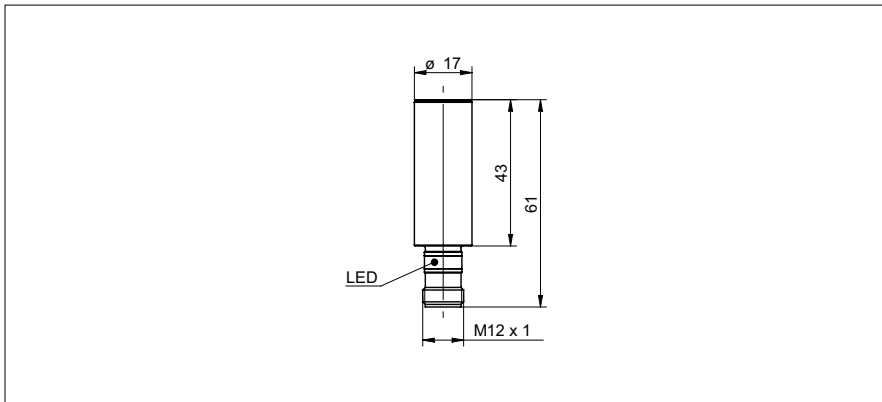

general data

mounting type	quasi shielded
special type	Hygiene design
nominal sensing distance S_n	8 mm
hysteresis	2 ... 15 % of S_r
output indicator	LED red
Approvals/certificates	Ecolab EHEDG

electrical data

switching frequency	< 500 Hz
voltage supply range +Vs	10 ... 30 VDC
current consumption max. (no load)	10 mA
output circuit	NPN make function (NO)
voltage drop Vd	< 2 VDC
output current	< 200 mA
output current (at cleaning temperature)	< 100 mA
short circuit protection	yes
reverse polarity protection	yes

mechanical data

type	cylindrical smooth
material (sensing face)	LCP
housing material	stainless steel 1.4404 (V4A); LSR
dimension	17 mm
housing length	61 mm
connection types	connector M12

ambient conditions

operating temperature	-40 ... +80 °C
cleaning temperature	80 ... +100 °C (30 min/day)
protection class	IP 68/69K & proTect+

photo



connection diagram



- Sensor FDA compliant and Ecolab approved
- LSR = Liquid Silicon Rubber