

USER MANUAL

FOR UP BOX+

UP BOX+



Table of Contents

Precautions	4
Printer Body	5
Accessories	7
Unpacking	8
Installing Print Board	8
Installing Filament	9
Installing UP Studio Software	9
Initializing Printer	10
Automatic Platform Calibration	11
Automatic Nozzle Height Detection	12
Manual Platform Leveling	13
Preparing for Printing	14
Printer Control Buttons	15
LED Light Bar	16
Software Interface	17
Setup Wi-Fi	18
Product Activation	22
Loading a Model	23
Printing a Model	24
Pausing a Print Job	25
Rotating a Model	26
Scaling a Model	27

Table of Contents

Moving a Model	28
Making Copies	29
Merging and Saving Models	30
Printing Preference	31
Printing Parameters	33
Converting a 2D Picture into a 3D Model	34
Machine and Software Settings	36
Controlling Multiple Printers with USB	37
Printer Info and Naming a Printer	38
Printing Techniques	39
Fine Manual Calibration	40
Setting Compensation Values	42
Maintenance	43
Filament Check and Blackout Recovery	44
Troubleshooting	45
UP BOX+ Specifications	46



Precautions

1 UP BOX+ 3D printer only works with the power adapter provided by the original manufacturer, otherwise the machine could become damaged or even cause a fire hazard. Keep the power adapter away from water and high temperature environments.

2 During printing, the temperature of the nozzle of UP BOX+ could reach 260°C and the print platform could reach 100°C. Do not touch these parts with your bare hands while they are hot—not even with the heat resistant gloves included with the machine—as the temperature could damage the gloves and injure your hands.



Warning label on printer:
High Temperature,
do not touch!

3 During printing, the nozzle and the print platform could be moving at high speeds. Do not touch these parts while they are moving.



Warning label on printer:
Moving Parts, do not touch!

4 Wear goggles when removing the supporting material from models, or detaching models from the print board.

5 When printing with ABS or PLA, the plastics will generate a slight odor. Run the printer in a well-ventilated environment. We also suggest you put the printer in an environment with a stable temperature as unwanted cooling could cause adverse effects to the print quality.

6 When the UP software is sending data to the printer—indicated on the status bar on the left bottom corner of the software interface with the text "sending layers"—do not unplug the USB cable as this will disrupt the data transfer and result in a printing failure. The USB cable can be unplugged after the data transfer is finished.

7 The UP BOX+'s ideal working temperature is between 15°C and 30°C with relative humidity between 20–50%. Users are recommended to discharge any static charge from the body before touching the machine to prevent interruption of printing and any potential damage to the printer.

Printer Body

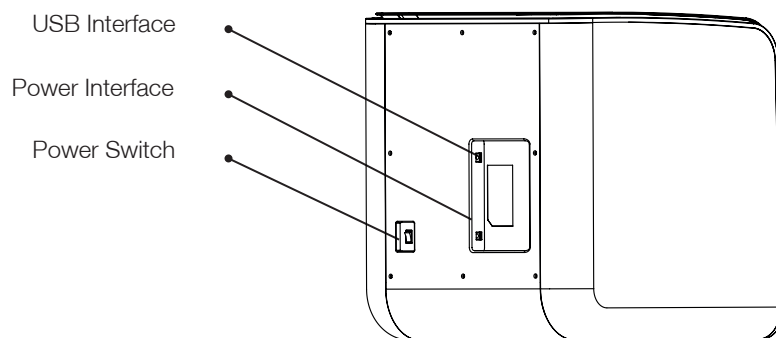
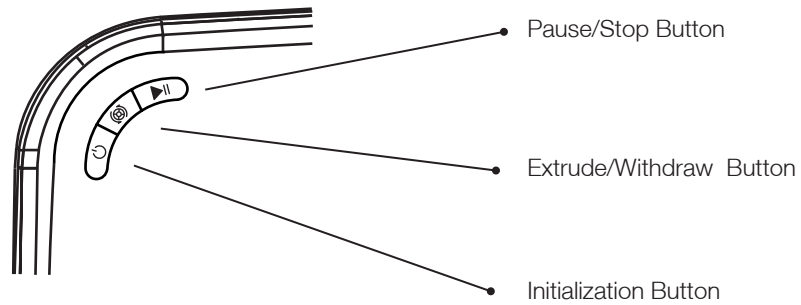
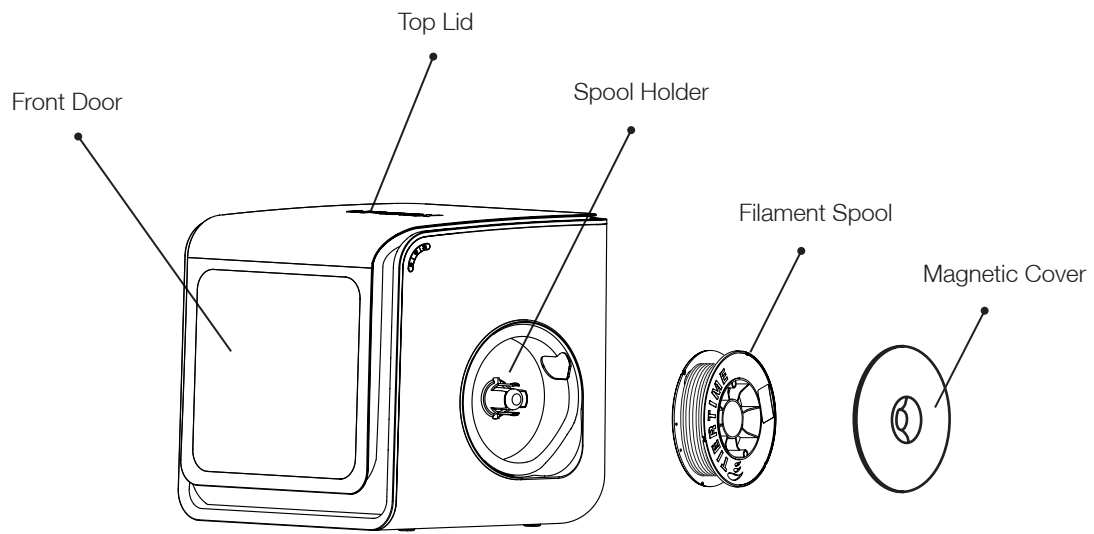

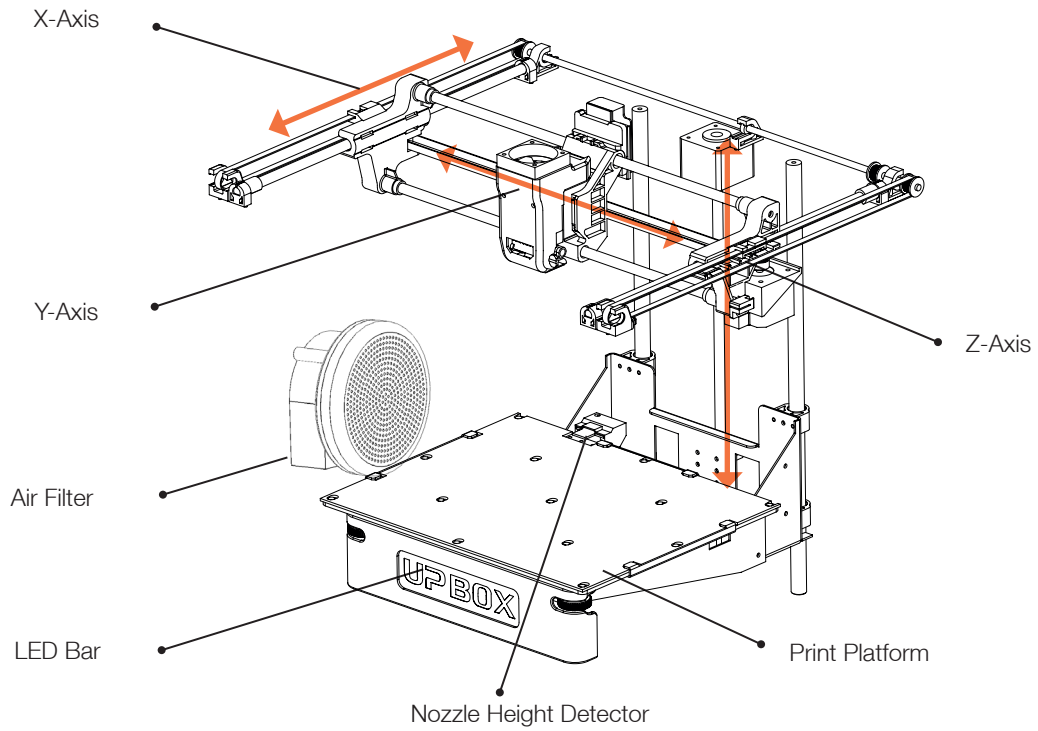

Print Head Mount

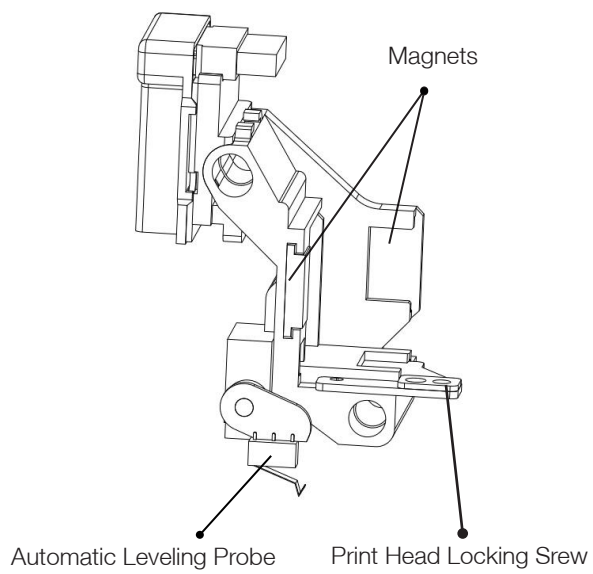

Print Head

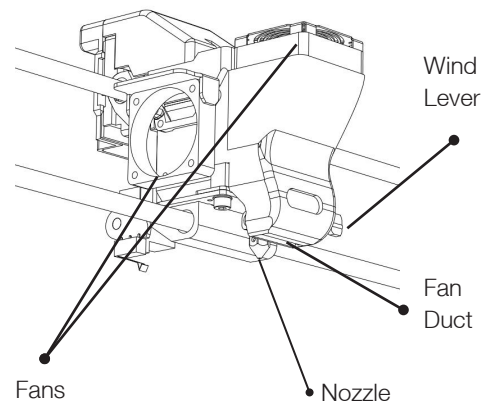

Accessories

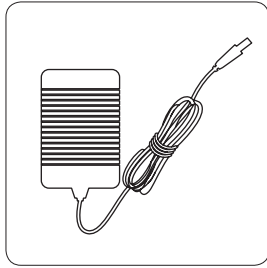

Power Adapter

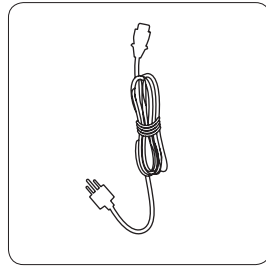

Power Cable

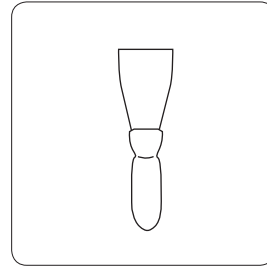

Scraper

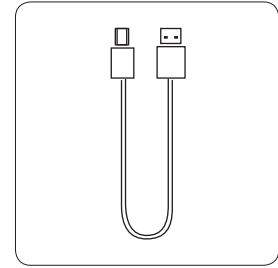

USB Cable

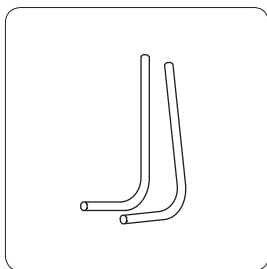

Hex Keys
2.0mm, 2.5mm

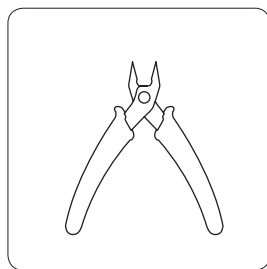

Plier

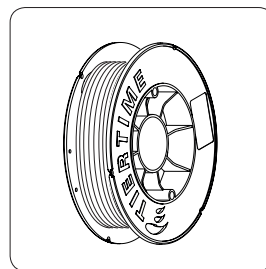

ABS Filament

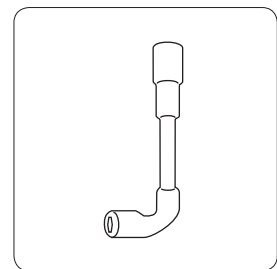

Nozzle Wrench

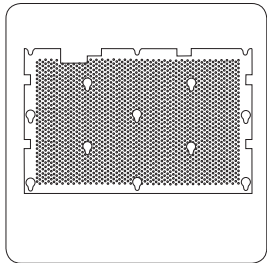

Perforated Print Board
(Perf Board)

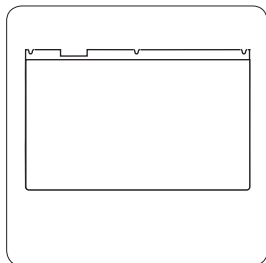

Perforated Print Board
(Perf Board) and UP Flex
Print Board

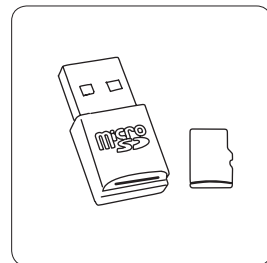

Micro SD card and
Reader

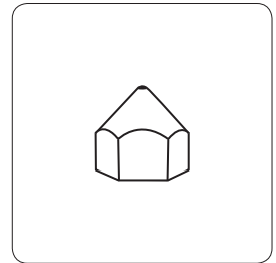

Print Head Nozzle

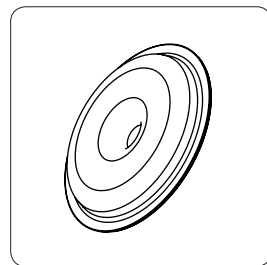

1kg Spool Cover

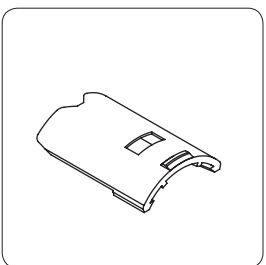

1kg Spool Rack Add-on

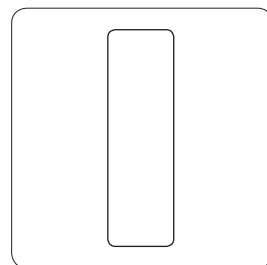

Calibration Card

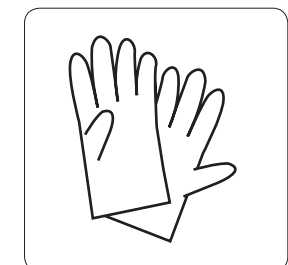

Gloves

All accessories may subject to change without prior notice. If anything is missing, please contact your local distributor at support@pp3dp.com.

Unpacking: Remove Foams and Nylon Ties

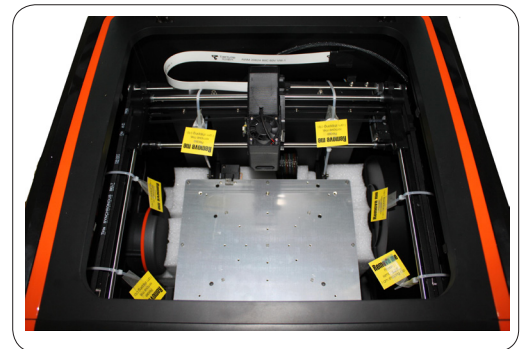

Lay down the foam at the bottom, turn it 90 degrees to remove, and no need to lift the platform.

Remove the nylon ties (labelled with "Remove me") from the smooth rods.

Keep the packaging material handy. You may need it when shipping the product in the future.

Installing Print Board

1. Position the print board on the build platform so that all the flat head screws on the heating plate are inside the holes on the print board.
2. Press the print board and the heating plate together at the lower left and lower right corners. Then slide the print board forward to lock it onto the heating plate.
3. Make sure all holes are locked properly so that the print board is flat.
4. Install or remove the print board when the platform and print board are cool.

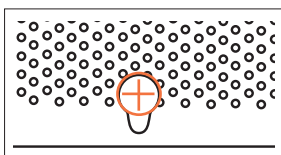

Unlocked

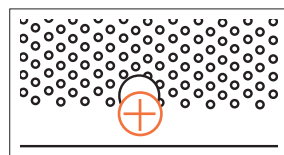

Locked

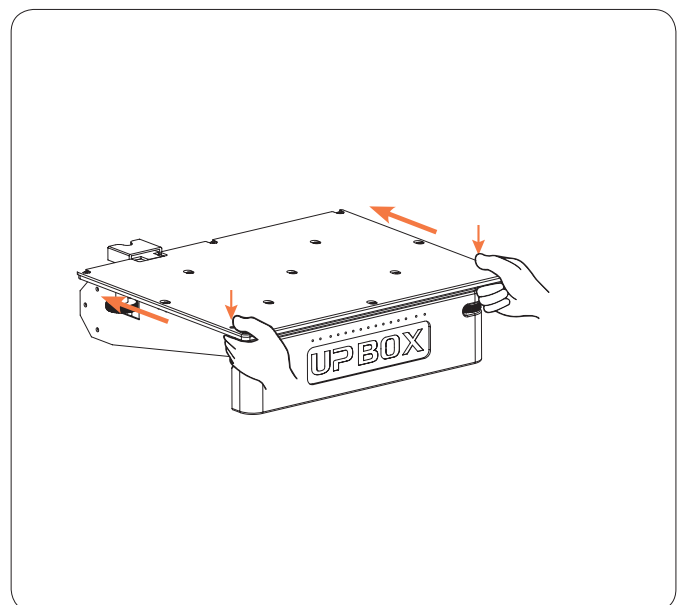

Install Print Board

Installing Filament

1. To install the filament spool, open the magnetic cover and insert the filament into the guiding tube at the spool holder.
2. Push the filament into the guiding tube until it comes out from the other end. Put the spool onto the spool holder and cover the spool with the magnetic cover.

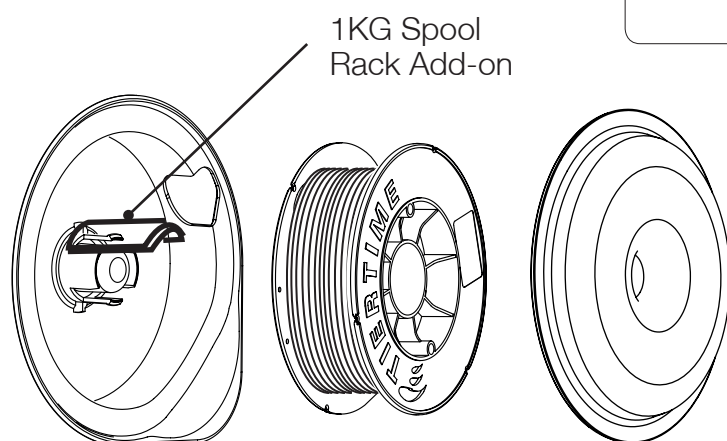
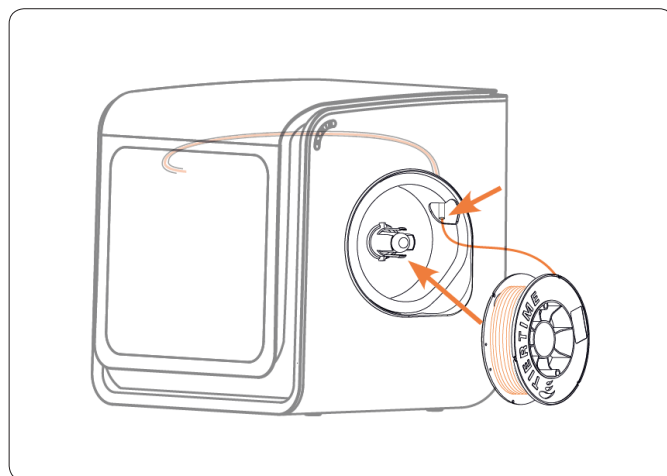

1KG Spool
Rack Add-on

To use 1KG spool, put the Spool Rack Add-on onto the original spool rack. A protruding magnetic cover is also provided with the machine to accommodate thicker spools.

Installing UP Studio Software

1. Go to the Support Section of www.up3d.com to download the latest version of the UP Studio. The Mac version of the UP Studio can only be obtained through Apple App Store.
2. Double-click the setup.exe file to install the software. (The default installation path is C:\Program Files\UP Studio\). A pop-up window will appear. Select "Install" and follow the instructions to finish. The printer's driver will be installed in the system.

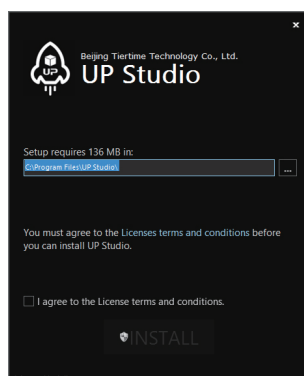

Initializing Printer

Initialization is required every time the machine is switched on. During initialization, the print head and the print platform move slowly and hit the endstops of the XYZ axes. This is essential as the printer needs to find the endpoints to each axis. Other software options will light up and become available for use only after initialization.

There are two ways to initialize your printer:

1. The UP BOX+ can be initialized by clicking the "Initialize" option in the software menu (shown above).
2. When the printer is idle, press and hold the initialization button on the printer.

Other functions of Initialization Button:

1. Stop the current print job: During an on-going print job, press and hold the button.
2. Reprint the last job: Double-press the button.

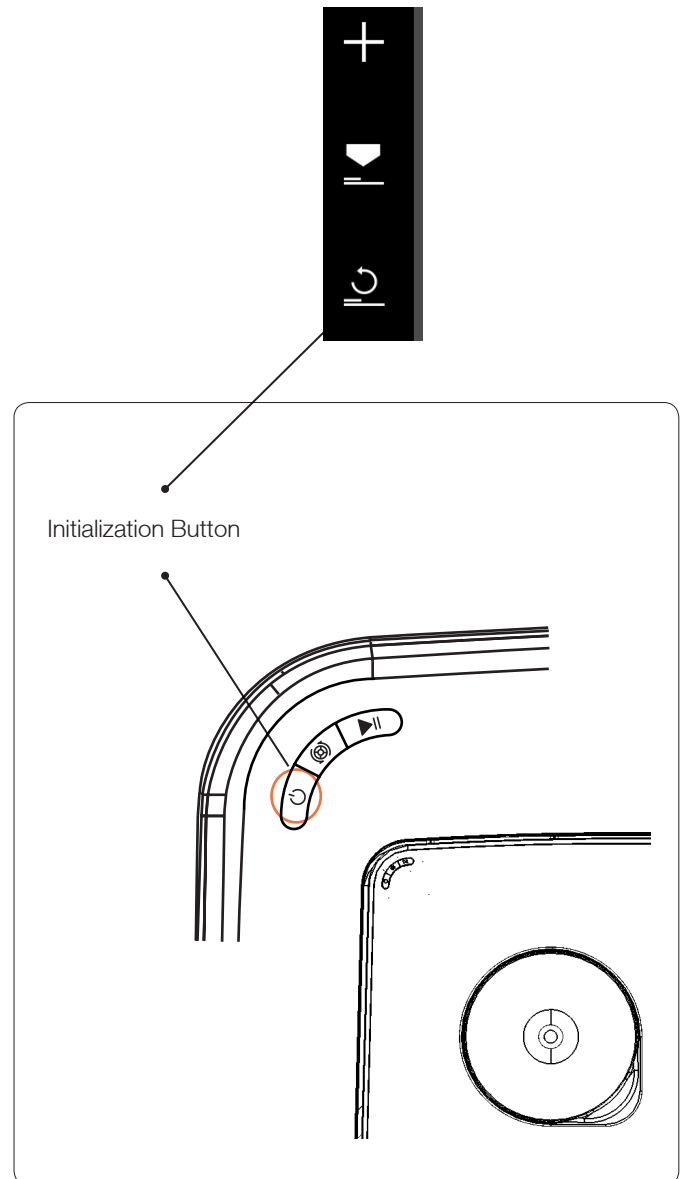

Automatic Platform Calibration

Platform calibration is the most important step for successful printing as it ensures part adhesion on the first layer. Ideally, the distance between the nozzle and the platform is constant, but in reality the distance varies at different positions due to many reasons (e.g. a slightly tilted platform), which could cause warping on prints or even a complete print failure. Fortunately, UP BOX+ introduces the features like automatic platform leveling and automatic nozzle height detection, which can make the calibration process finish quickly and easily.

In the Calibration section, click Auto Level to initiate auto leveling. The leveling probe will be lowered and start to probe nine positions on the platform. After probing the platform, the leveling data will be updated and stored in the machine. The leveling probe retracts automatically.

Nozzle height detection will be started automatically after auto leveling process. The print head will move toward the nozzle height detector. Eventually, the nozzle will touch and press the thin metal sheet on the device to make the measurement.

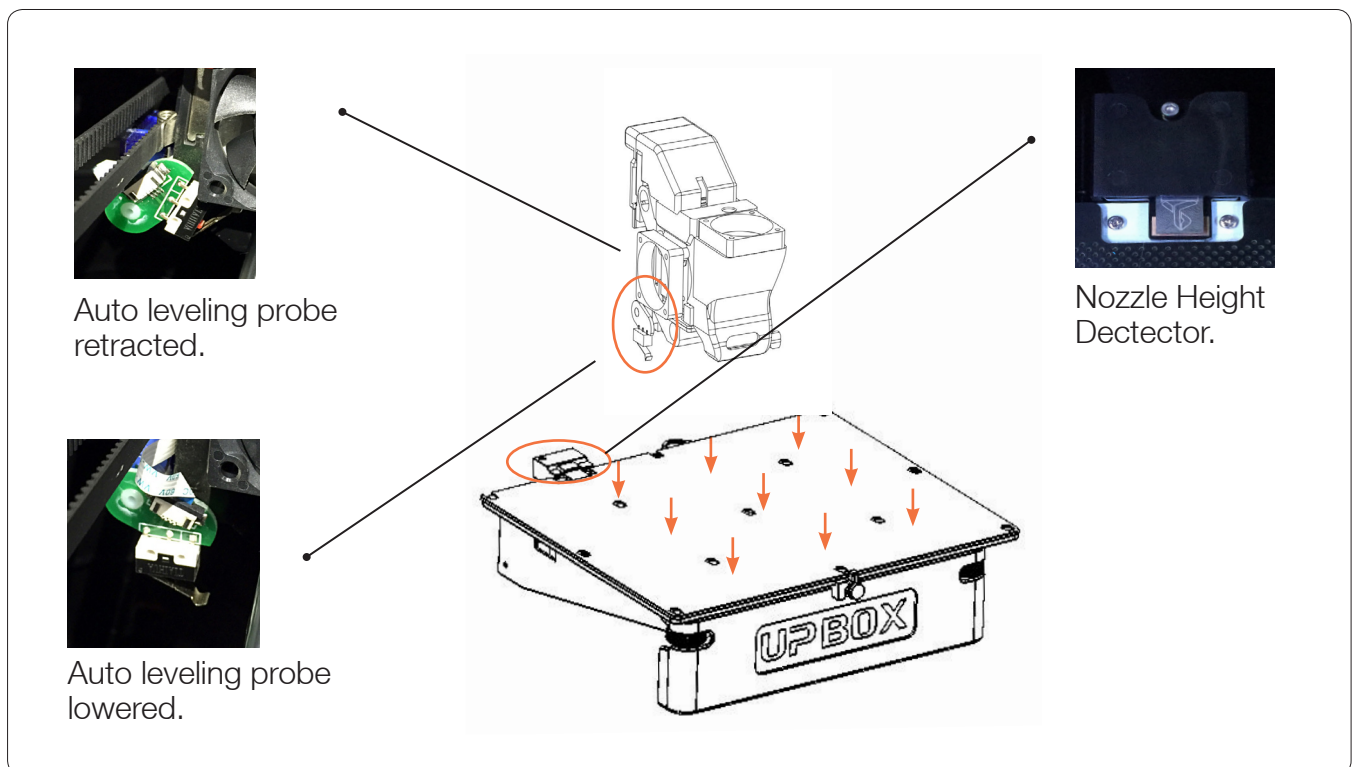
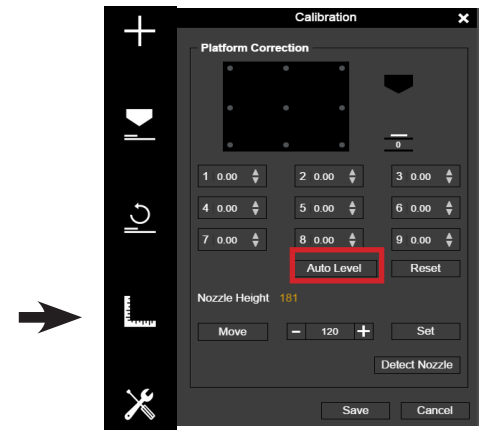

Calibration Tips:

1. Perform calibration when the nozzle is not heated.
2. Remove residual plastic on the tip of the nozzle before calibration.
3. A print board should be in place on the platform before calibration.
4. Autoleveling and nozzle height detection can only be initiated when nozzle temperature is under 80 °C.

Automatic Nozzle Height Detection

You may initiate the Automatic Nozzle Height Detection without the Autoleveling.
In the Calibration section, click " Detect Nozzle".

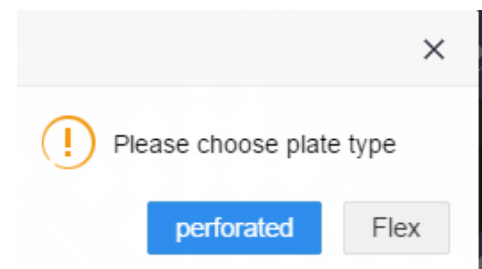
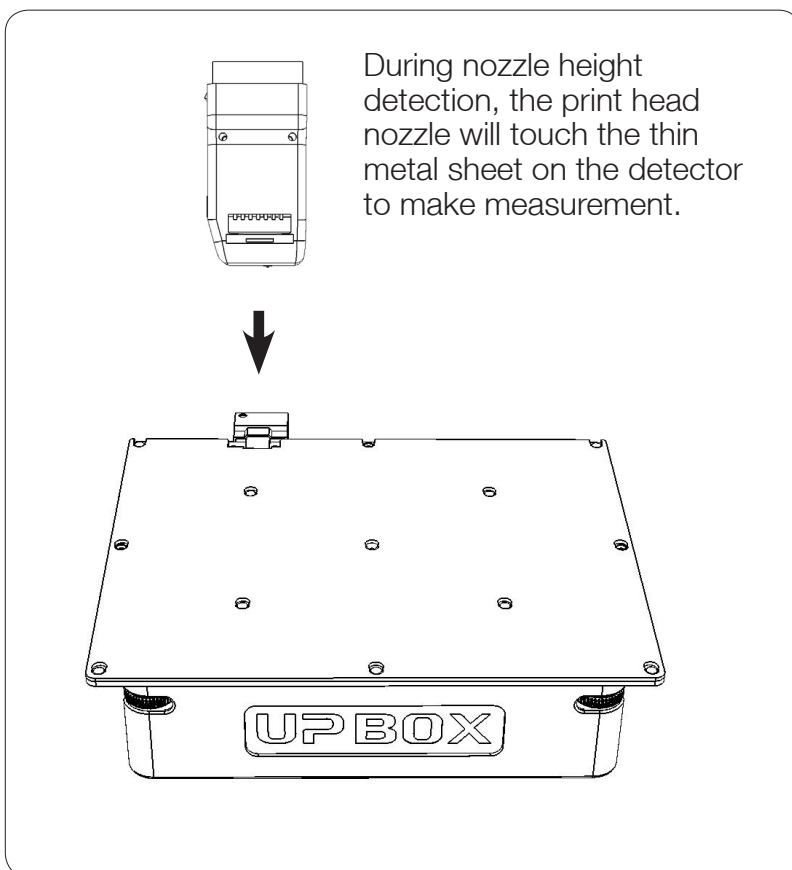
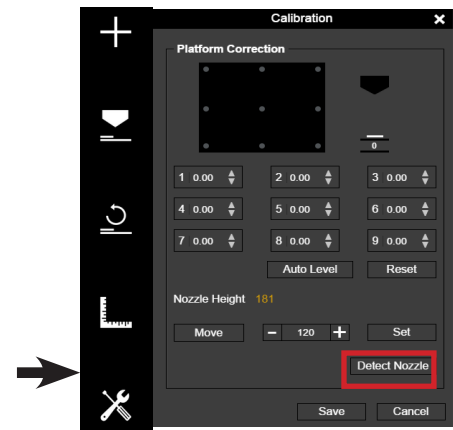

After nozzle height detection, the software will ask which type of print board is used on the machine, choose the currently used type of board to finish the measurement.

If consistent warping still occurs after auto-leveling, it may be due to a severe unleveling of the platform which exceeds the capability of the auto-leveling function. In which case, you should perform a manual leveling before auto-leveling (see the next page).

You may also level the platform without using the auto-leveling and nozzle detection functions. Please refer to Page 40 for details.

Manual Platform Leveling

Usually users do not need to adjust the platform manually. This is only necessary if the automatic leveling function was unable to effectively level the platform.

There are four screws under the platform of UP BOX+: two knobs in the front and two knobs under the platform at the back. These knobs can be fastened or loosened to adjust the leveling of the platform.

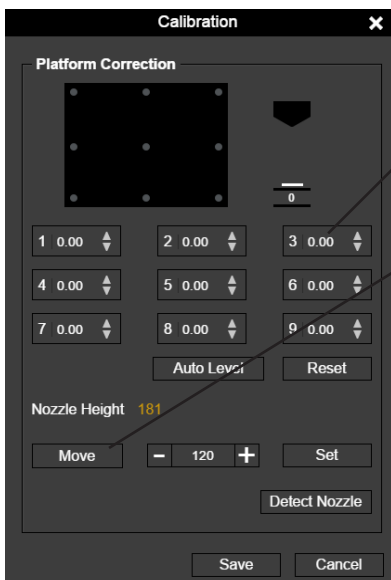
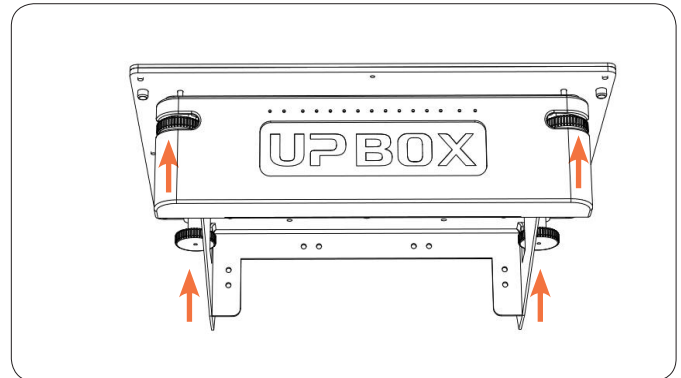

In the calibration section use the reset button to set all the compensation values to zero. Then use the nine numbered buttons to move the platform to different locations.

You can also use the "Move" button to move the print platform to a particular height.

First move the print head to the center of the platform and move the platform to almost touching the nozzle (e.g. nozzle height). Use the Calibration Card to determine the correct platform height.

Try to move the Calibration Card and feel the drag between the platform and the nozzle. Make sure you can feel the similar drag resistance at all 9 positions by moving the print head and adjusting the screws while the platform height is fixed.

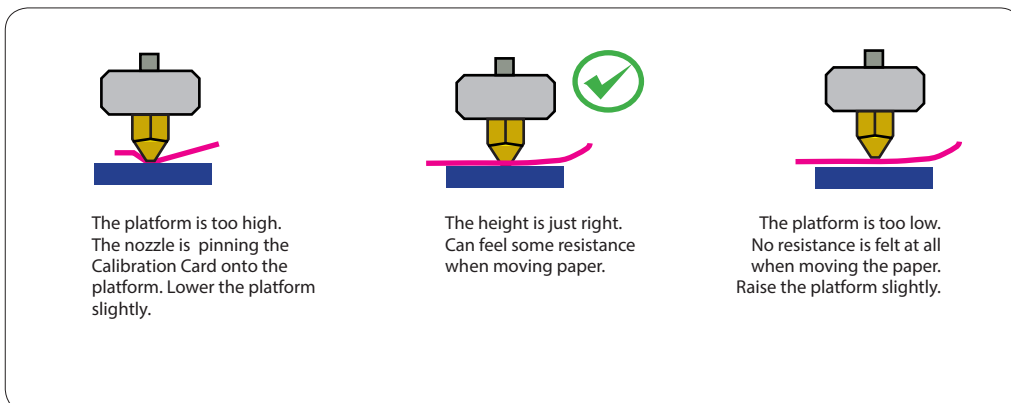

Preparing for Printing

- 1 Make sure the printer switched on and connected to a computer. Click the "Maintenance" button in the software.

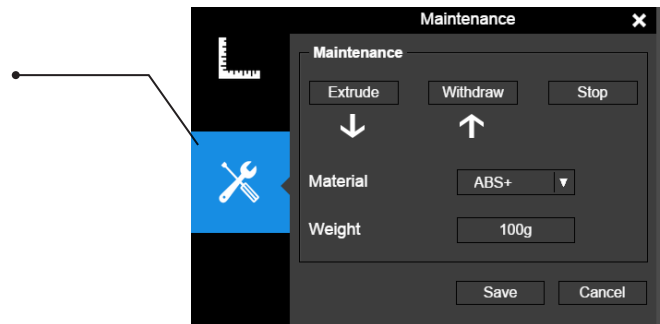

- 2 Choose ABS or the material you choose from the dropdown material list, and input the filament weight.

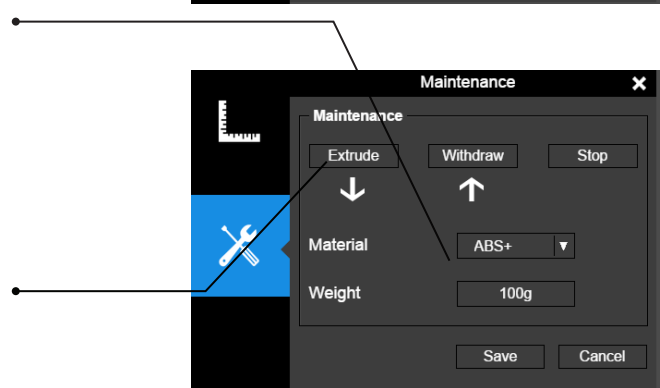

- 3 Click "Extrude". The print head will start to heat up. About five minutes, the temperature of the print head will reach the melting temperature, e.g. for ABS, it is 260°C. The printer will buzz and the print head will start to extrude.

- 4 Gently insert the filament into the small hole on the print head. The filament will be fed into the print head automatically when it reaches the extruder gear inside the print head.

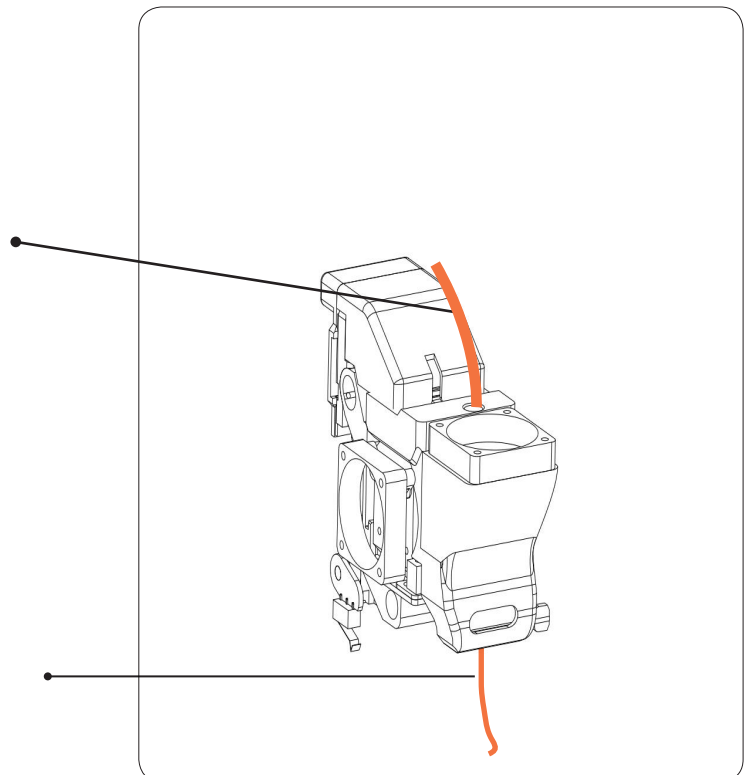

- 5 Check the nozzle for plastic extrusion. If plastic is coming out from the nozzle, it means the filament is loaded correctly and the printer is ready for printing. (The extrusion will stop automatically after a while.)

Printer Control Buttons

Printer Control Buttons

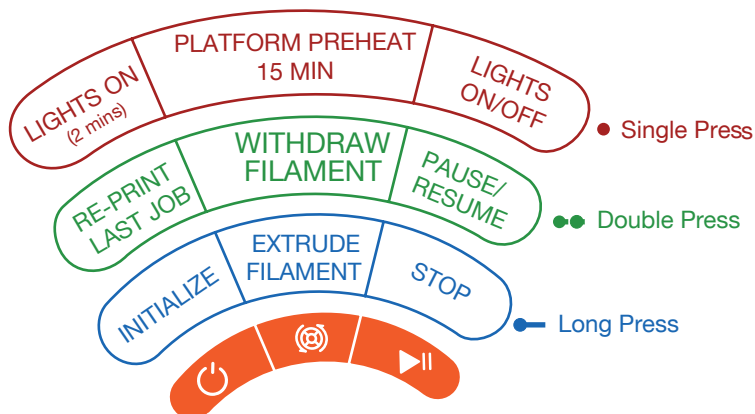
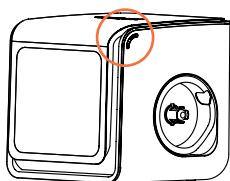

LED Light Bar and Front Door Check

STATUS DISPLAY		
UPBOX	Orange Pulsing:	Printer switched on waiting to be initialized
UPBOX	Green Rotation:	Printer initialized waiting for job
UPBOX	Blue Rotation:	Fast-Print job spooling from computer. Slow-Printing
UPBOX	Blue Pulsing:	Print job paused
UPBOX	Red Pulsing:	Print Finished Single Letter Remains On:
		SD CARD ERROR PLATFORM TEMPERATURE ERROR PRINT HEAD TEMPERATURE ERROR MOTION SYSTEM ERROR PRINT HEAD ERROR
UPBOX		Progress Bar for pre-heating and printing

When a print job is finished, the LED light bar will be in RED color. Under such condition, the machine will not respond to any command and print jobs. This is to prevent unwanted actions that may crash the print head into the printed object.

To resume to normal, the front door must be opened once after a print job is finished.

LED Light Bar



Printing and Pre-heating
Progress bar.



Sleeping Mode
Alternated lighting of progress
bar

Sleeping mode: Machine will enter the sleeping mode after it has been idling for 2 minutes when it is not initialized. Single press the initialization button can exit the sleeping mode.

The sleeping mode is only available in certain countries. If the machine does not enter the sleeping mode, it does not mean it is malfunctioning.

Software Interface

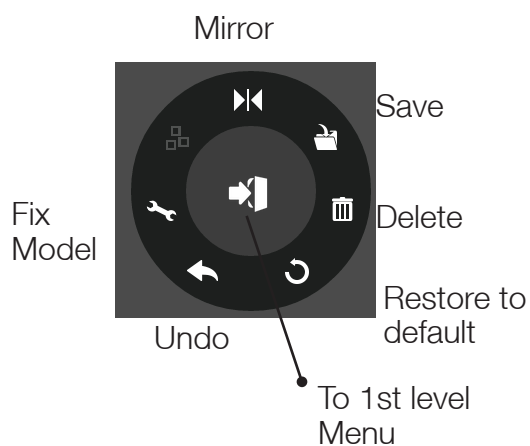
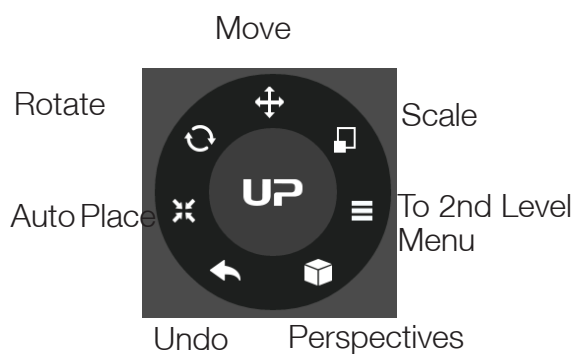
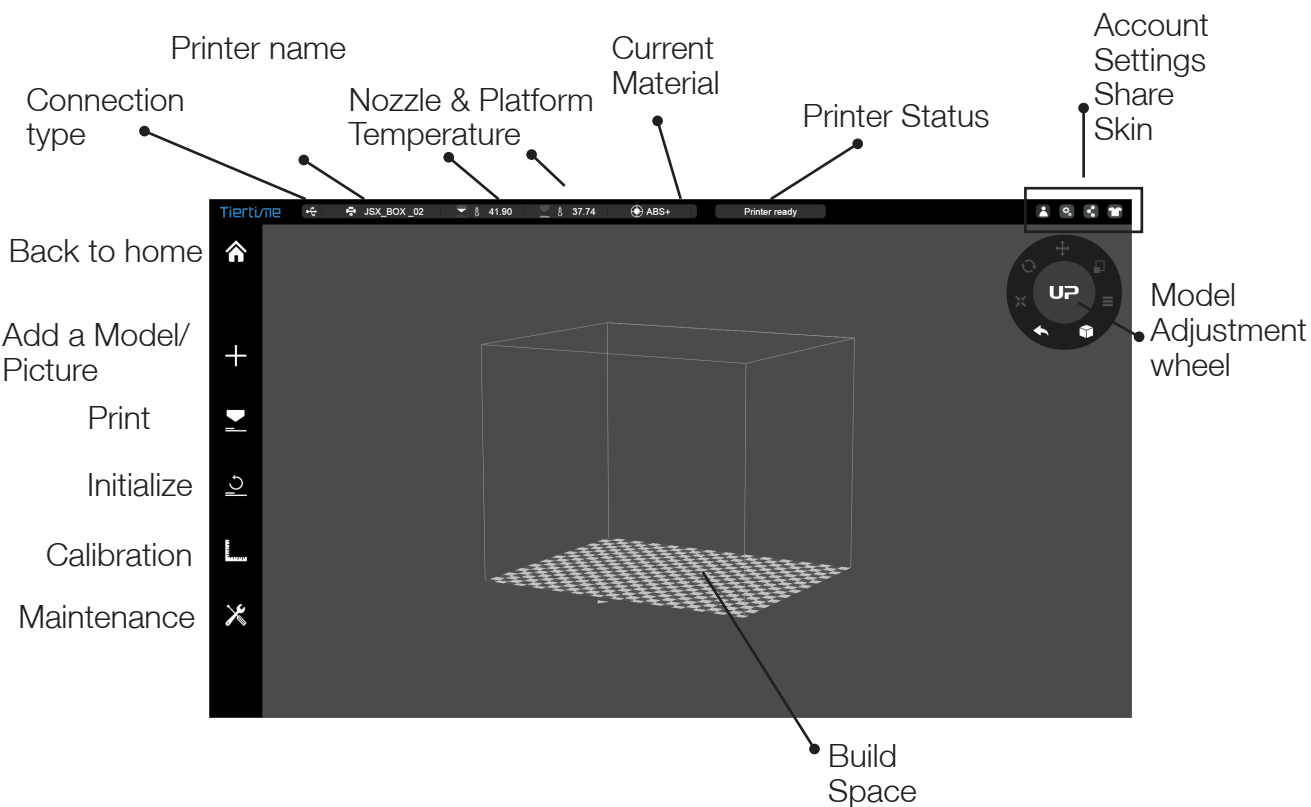
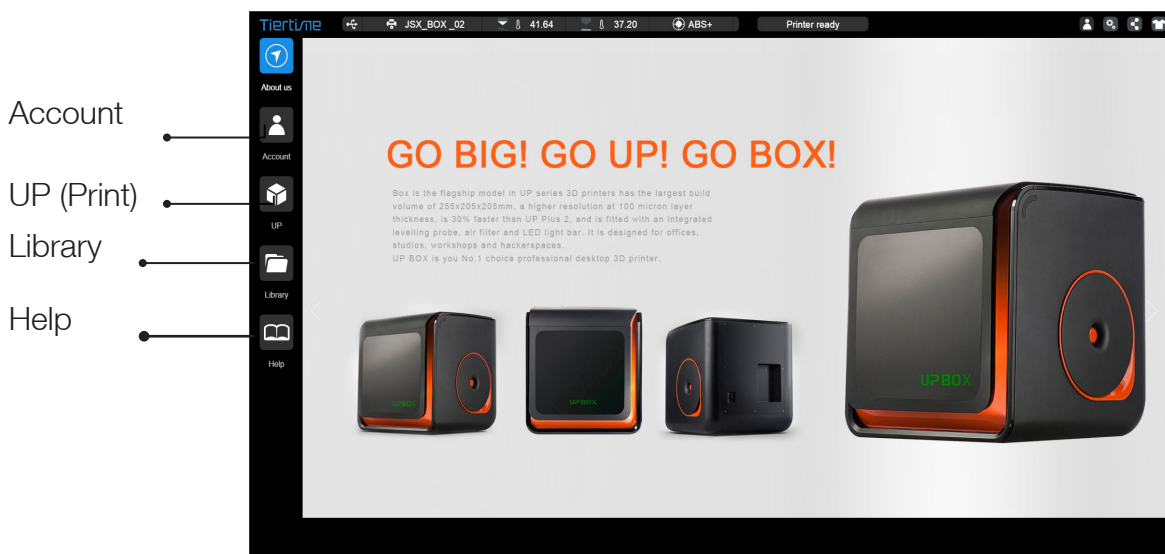

Machine Settings - Wi-Fi Connection

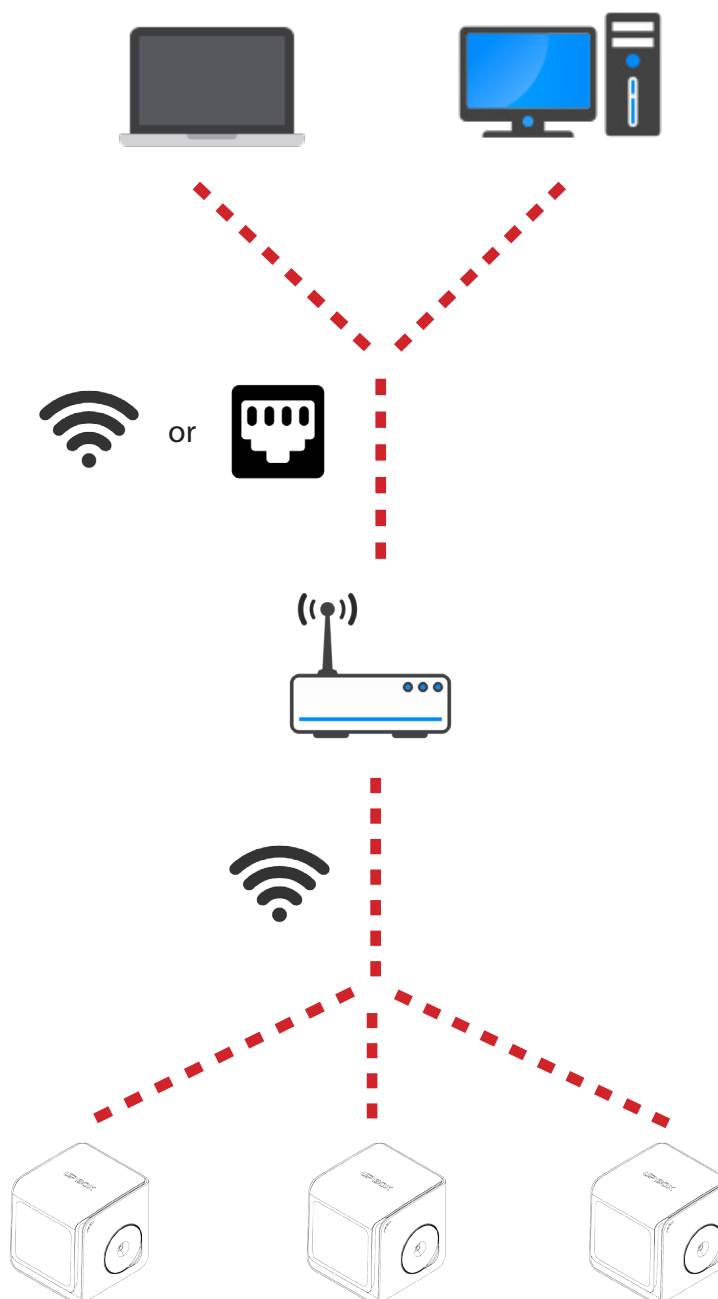

Connecting to UP BOX+ through Wi-Fi requires a Wireless Local Area Network (WLAN). The computer and the printers must connect to the same WLAN (same SSID) before they can communicate.

In order to achieve stable Wi-Fi connection, It is highly recommended to use the printer under a capacious Wi-Fi environment. A crowded network or an area with many Wi-Fi networks are known to cause interruption during data transfer.

Wi-Fi Setup

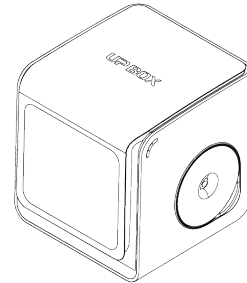

1

Connect UP BOX+ to a computer through USB.

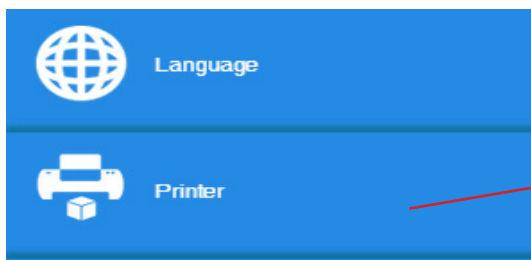
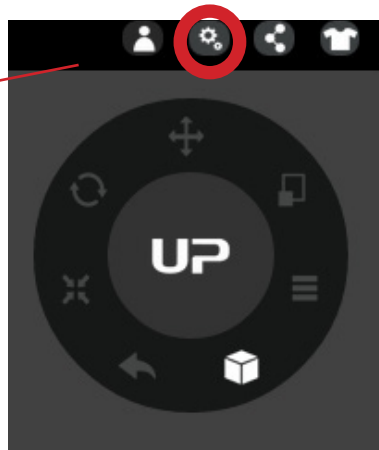

2

At the top right corner click the printer tab
Click the "Printer Detail" button.



3

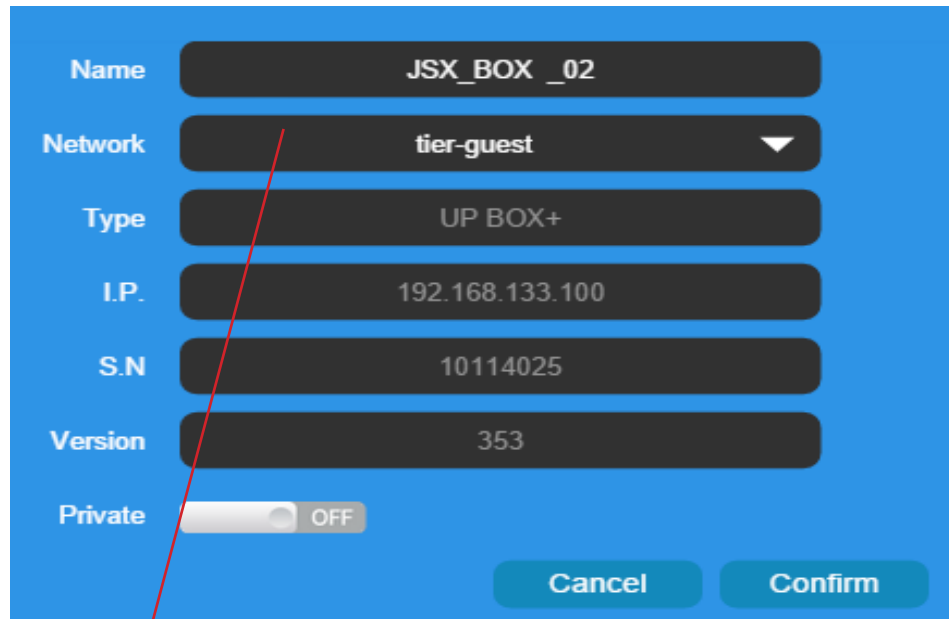

The screenshot shows a configuration form for a printer. The fields are: Name (JSX_BOX_02), Network (tier-guest), Type (UP BOX+), I.P. (192.168.133.100), S.N (10114025), Version (353), and Private (OFF). A red arrow points to the Network dropdown menu.

Click the dropdown menu to choose an available network.

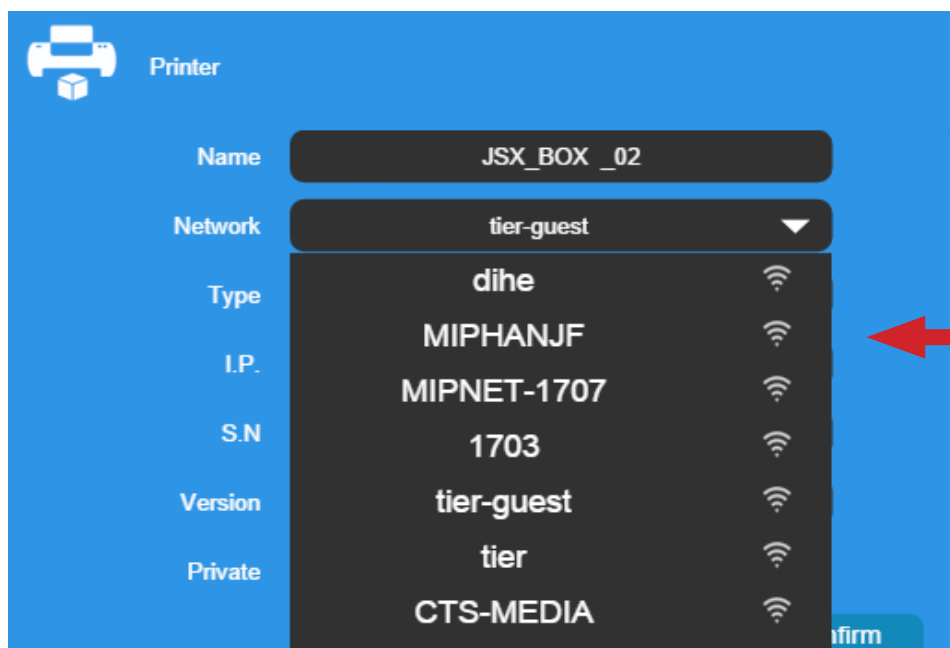

The screenshot shows the printer configuration screen with the Network dropdown menu expanded. The list of available networks is: dihe, MIPHANJF, MIPNET-1707, 1703, tier-guest, tier, and CTS-MEDIA. A red arrow points to the list.

Choose your network from the drop down list.

4

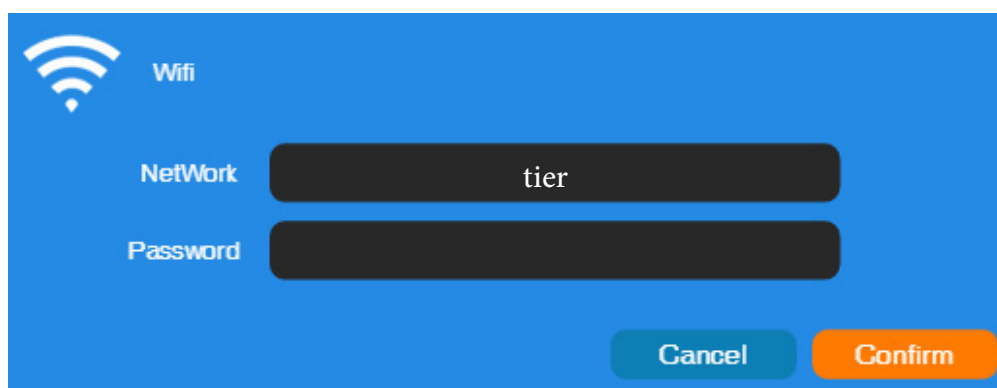

Input the password for the Wi-Fi network.

5



If “Private” is set to ON, a private password can be optionally added to limit the printer access via Wi-Fi to trusted users. Please note that the password for private access is a weak protection that anyone who can connect the printer through USB connection can disable or change the password without any limitation.

6

Printer Tab

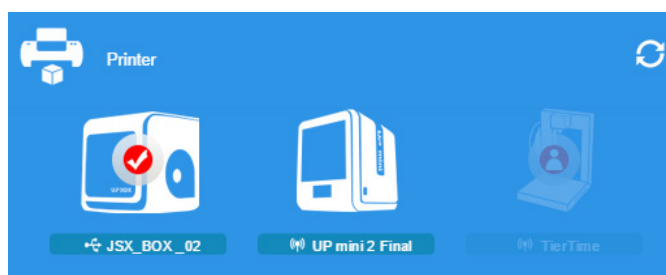

Disconnect USB and by clicking an icon, choose an available printer on the network to operate through Wi-Fi.

Product Activation

It is highly recommended to activate UP BOX+ as soon as possible to be able to access its unlimited printing power and the cloud based web functionality. The inactivated machine has limited printing times before the activation is done.

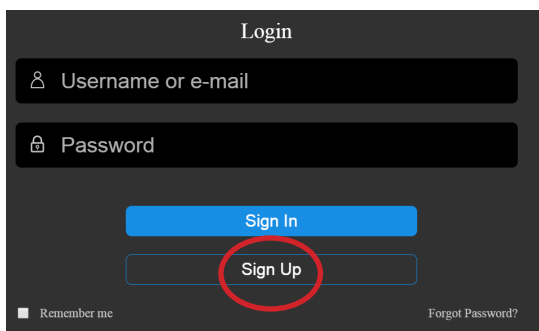

- 1 Press the "Account" button at the main menu
Click the "Sign UP" button.

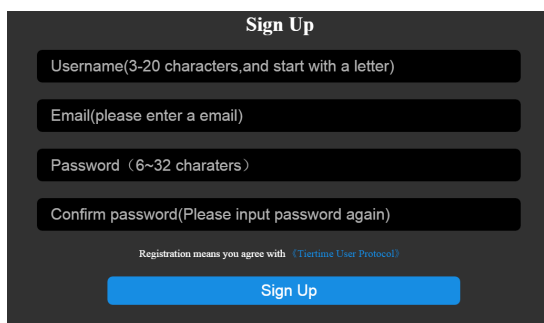
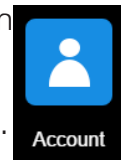

- 2 Register an UP account. If a user account is already available, skip to step 5.

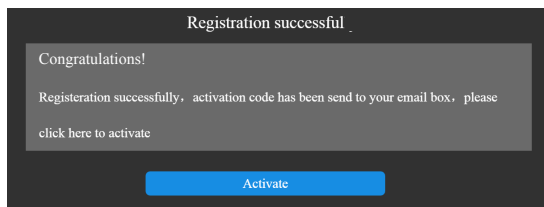

- 3 When finished the registration, go the registered mail box, activate the account through the activation email.



- 4 Connect the printer to a computer.

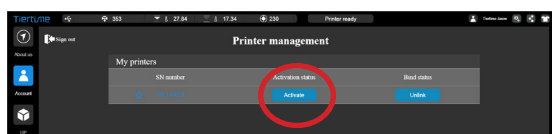

- 5 Go to the account section and Sign In. User will see a printer management list. Find your printer in the list, and click the "Activate" button to activate your printer.

Loading a Model

- 1 Click "Import Model or Image", choose to open a 3D model.

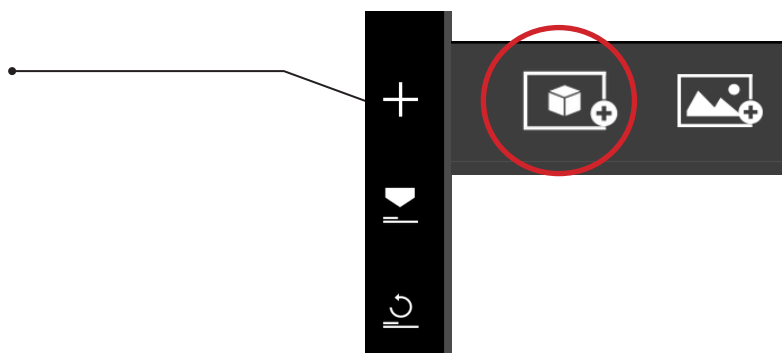

- 2 Choose your model.

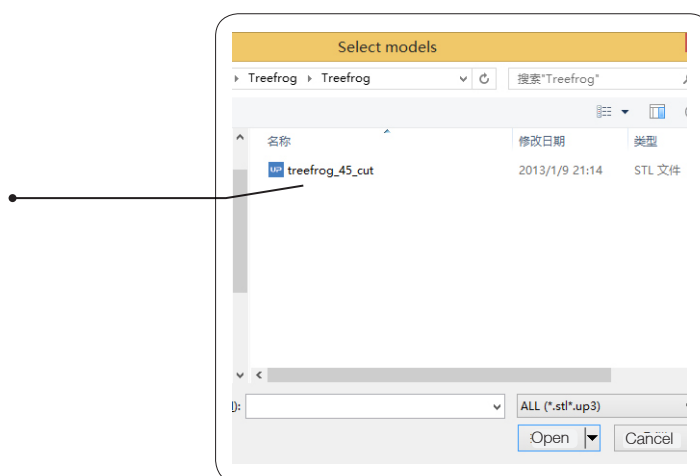

- 3 The loaded model will appear on the print plate.

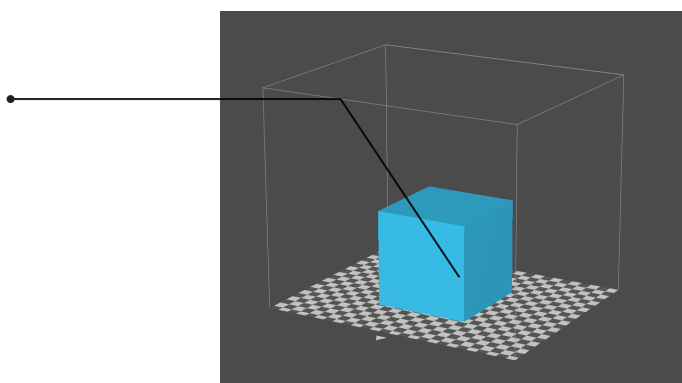

- 4 Click "Print" to open the print preview window.

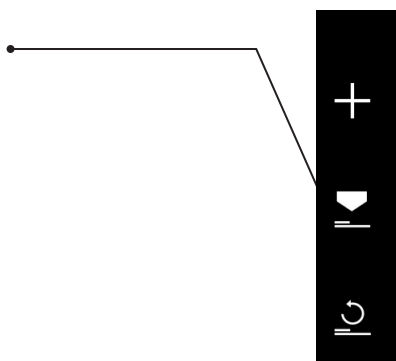

Printing a Model

Make sure the printer is connected to a computer through USB or Wi-Fi (go to page 19 for details about Wi-Fi setting), and loaded a model.

- 5 Click the print button to open the print interface

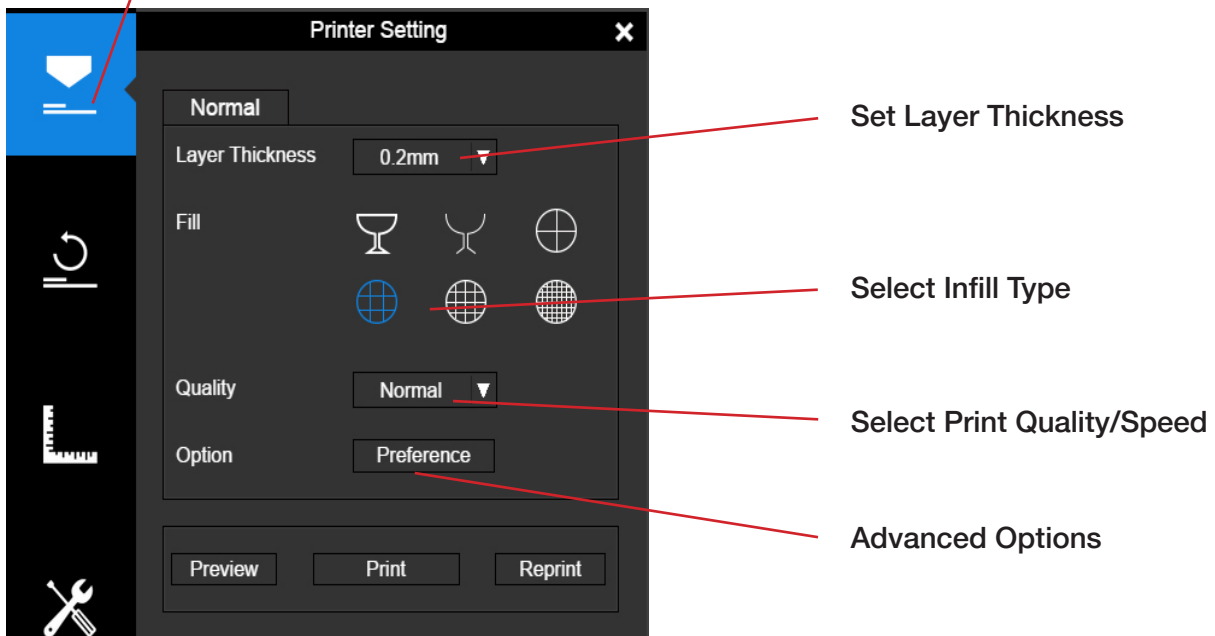

Surface: No top and bottom layers, no infill, single perimeter.

Shell: No infill, normal wall.

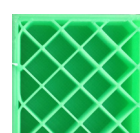
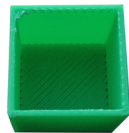

Big Hole

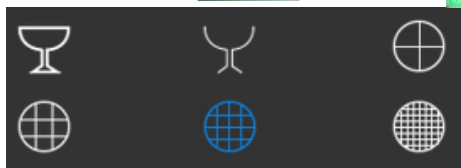

Hollow

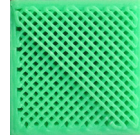
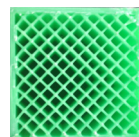
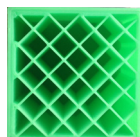

Solid Infill

Loose Infill

- 6 After sending the data, the program will show the amount of material and the time needed for the print job in a pop-up window. At the same time, the nozzle will start to heat up. The print will start automatically. Now your are safe to disconnect the printer from computer.

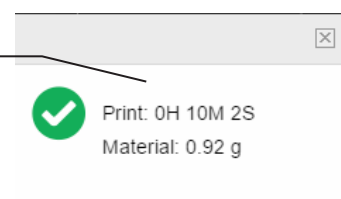

Printing Progress

Printing progress is shown in the LED progress bar on top of the UP BOX+ letters.

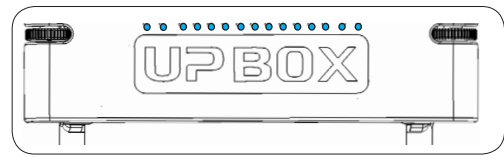

Pausing a Print Job

An on-going print job can be paused by clicking the "Pause" button on the left hand side menu.

Click the "Resume Print" to resume the paused print job. Once the print job is paused, the other buttons on the maintenance interface will be enabled.

You can change filament using the "Withdraw" and "Extrude" buttons. At this point user could even change materials.

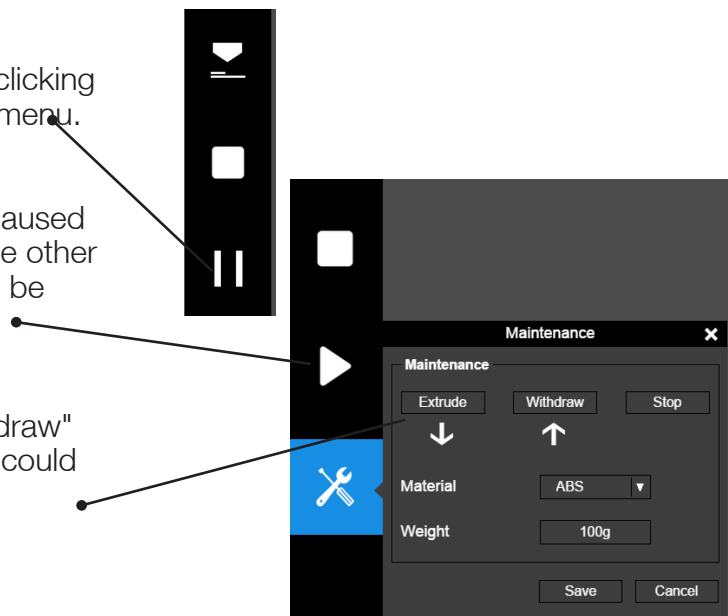

Pause a Print Job without using the UP Studio Software

During printing when the front door is opened, printing will be paused automatically. After closing the front door the print job will not be resumed until the user *double press* the pause button.

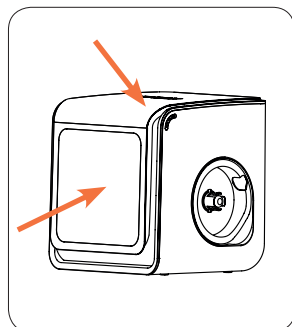

Alternatively, during printing, double press the Pause/Stop button, the print job will be paused. It is possible to use the Extrude/Withdraw button to change filament during the pause. *Double press* the pause/stop button again to resume the print job.

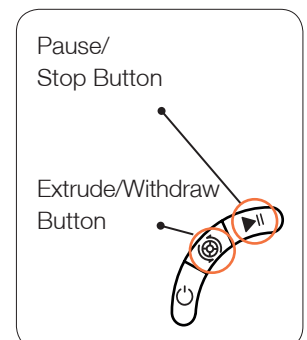

Rotating a Model

Choose the model and click the rotate button.



Choose the rotation axis

User could input a specific value or choose a preset value for rotation.

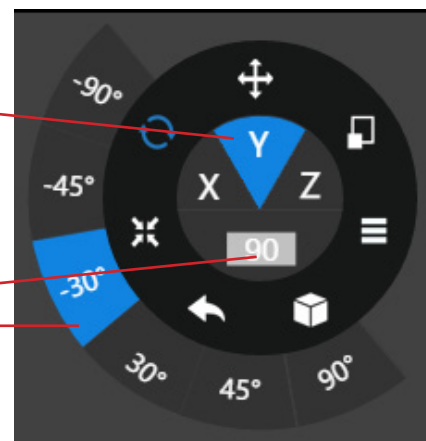

Alternatively, user may use the rotation guide to rotate the model in real time by click and drag using mouse.

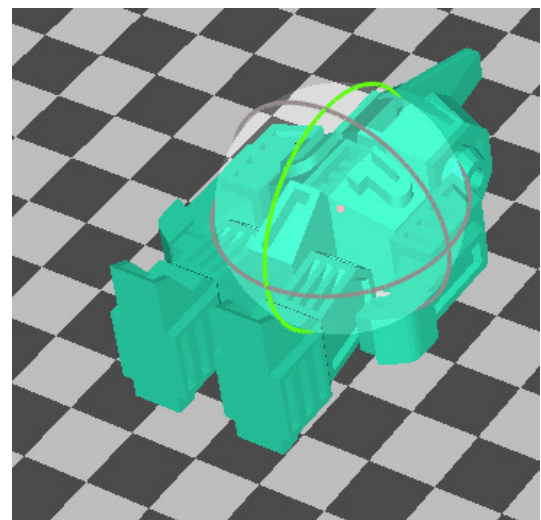

Scaling a Model

Choose the model and click scale button.

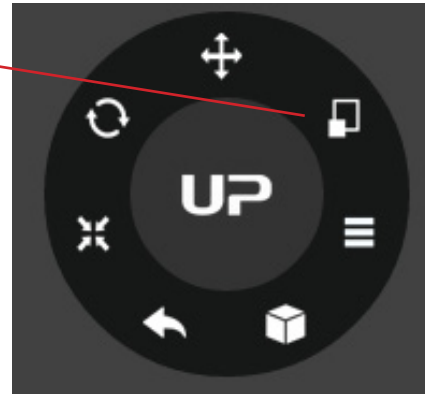

By default the scaling is in all axes. User could also choose a specific axis for scaling.

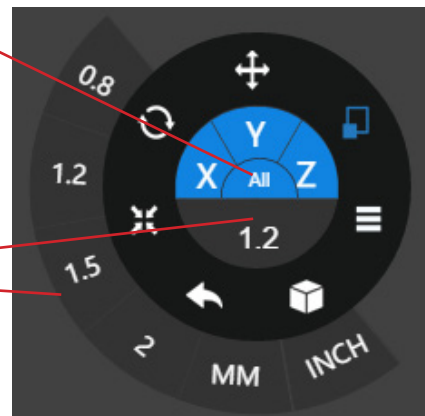

User may input a specific scaling factor or choose a preset value.

Click MM or INCH to convert the models to the size of corresponding units.

Alternatively, user may use the scaling guide on the model. User could scale in a specific axis or scale in all directions by click and drag using mouse.

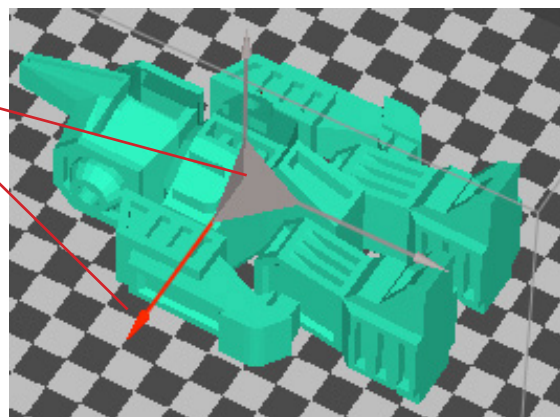

Move a Model

Choose the model and click the Move button.



Choose the direction of movement.

User may input a specific value or choose a preset value for the distance of movement.

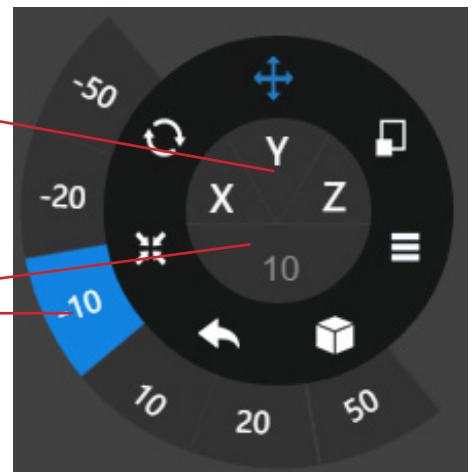

Alternatively, user may use the translational guide on the model to move on the X-Y plane or a single direction by click and drag using mouse.

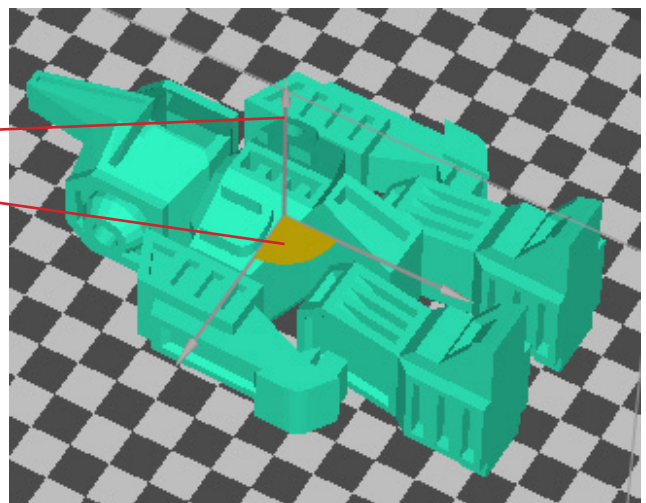

Making Copies

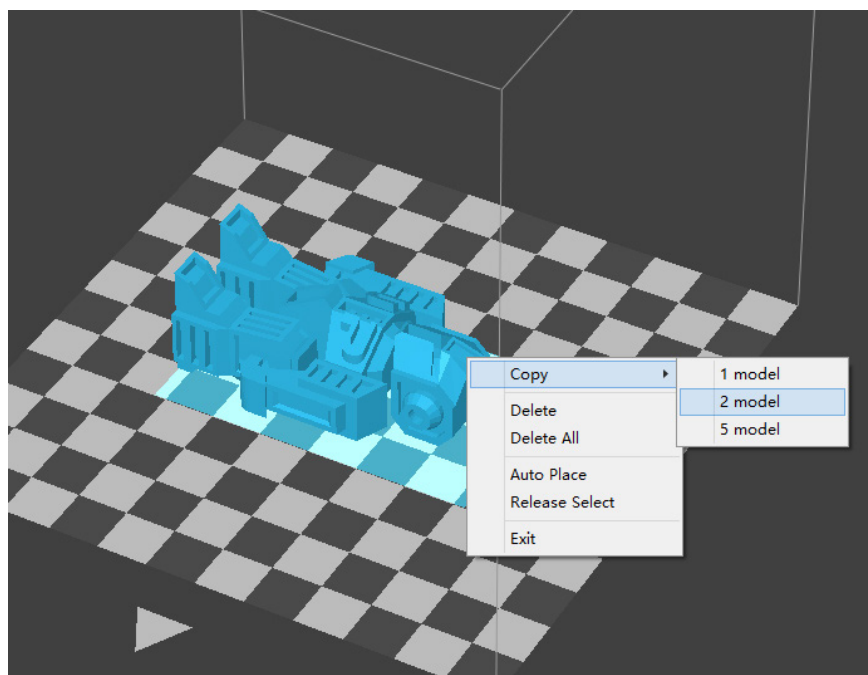

Choose the model by clicking it (highlighted), then right-click to bring up the menu and select the number of copies.

Repairing a Model

- 1 If the model contains defective surfaces, the software will highlight the defective surfaces in red. Click the "More" button to reach the second level menu.

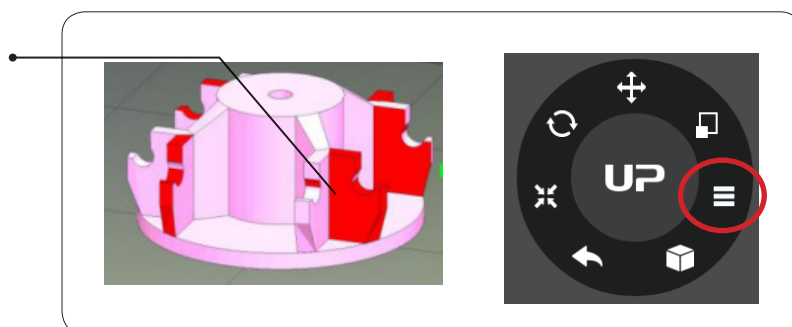

- 2 Click the "Fix" button to repair the model. The red defective surfaces will be changed to the normal color if the defects can be repaired.

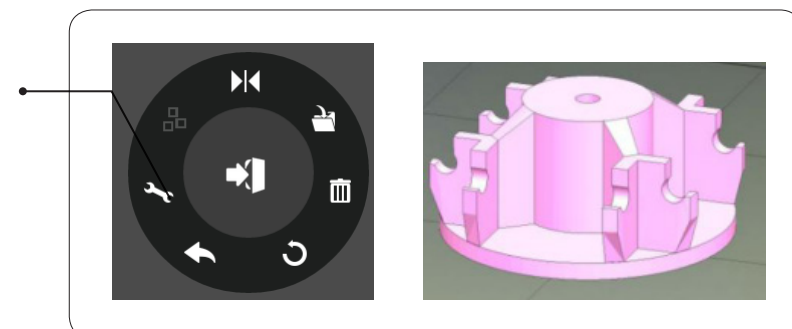

Merging and Saving Models

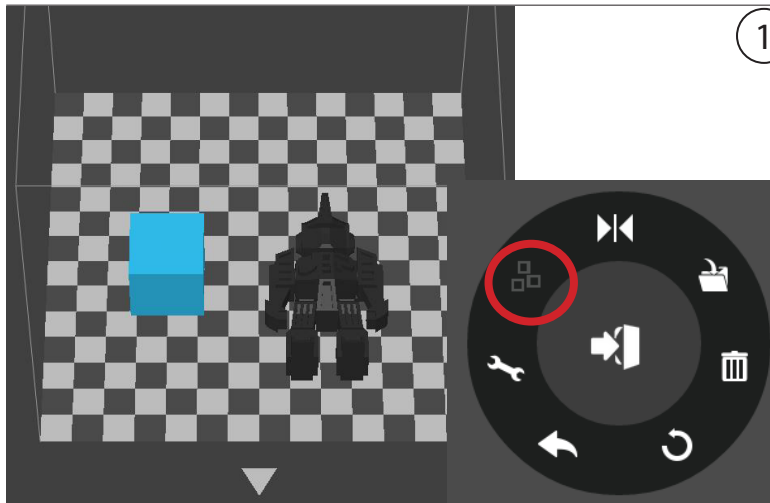

- 1 Ctrl/CMD-click all the models on the build plate.

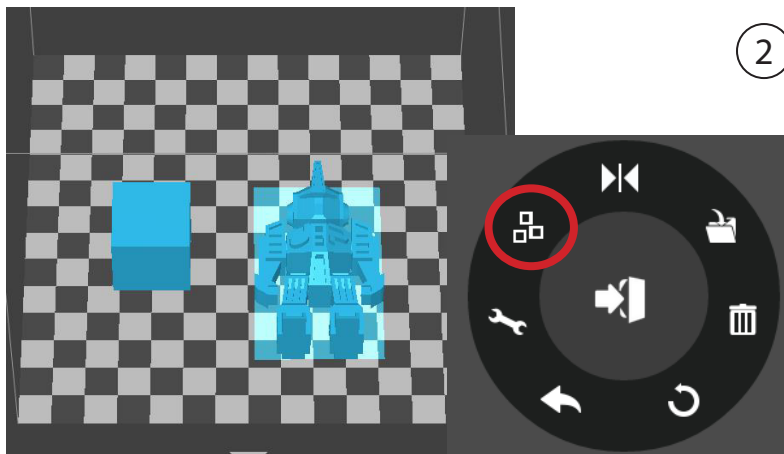

- 2 The Merge button on the second level of the adjustment wheel will become available. Click the "Merge" button to merge the models.

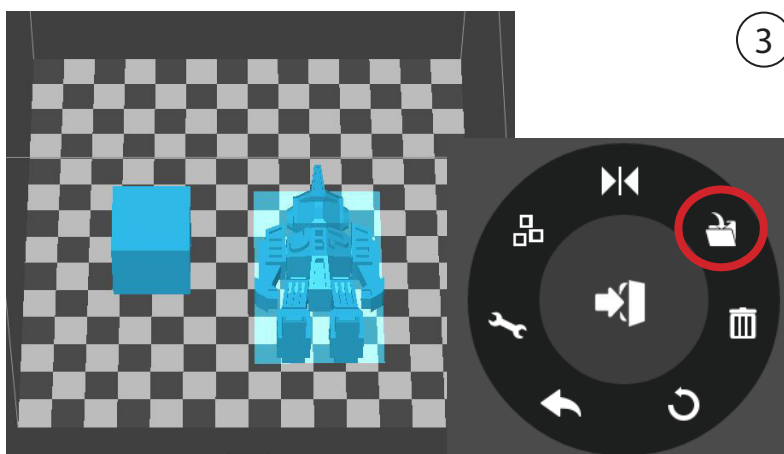

- 3 Click the "Save" button to save the merged models to the computer.

If models are placed too close together, their raft could overlap, which could hinder extrusion. Merging converts all selected models into one single model, so its raft would be calculated as a single model without overlapping. Merging could be a convenient option if a user wants to preserve the relative positions of a set of models.

Print Preference

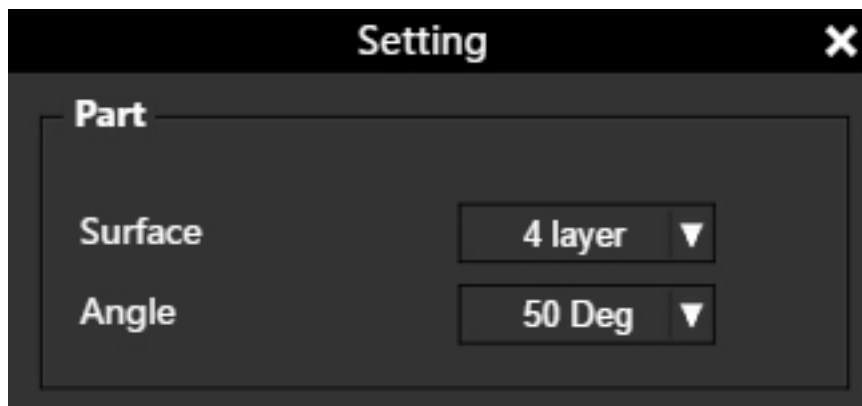

Surface: The number of layers that sealing the top and the bottom of the printed object.

Angle: This value determines at which angle the Surface layers start to be printed.

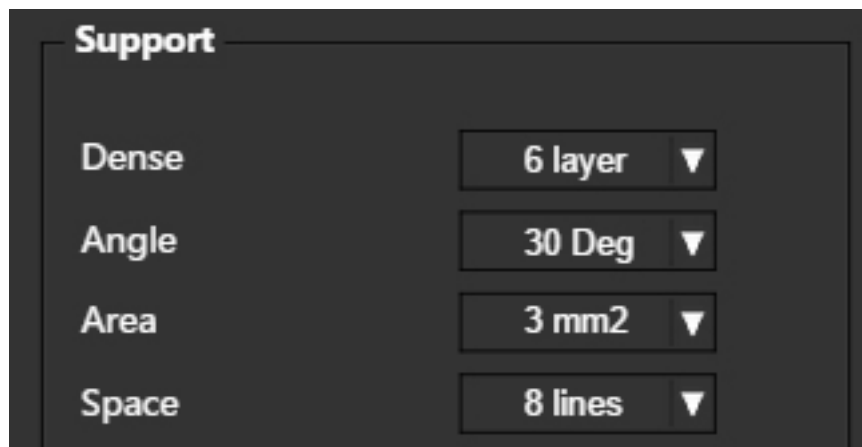

Dense: Choose the number of the dense layers between the support structure and the supported surfaces.

Angle: Determine the angle at which the support structure and the dense layers to be generated.

Area: Determine the minimal area of a surface that a support structure will be generated. The area smaller than this value will have no support structure generated.

Space: Determine how dense the support structure will be. The larger the value, the less dense the support.

Print Preference

No Raft	<input type="checkbox"/>
No Support	<input type="checkbox"/>
Stable Support	<input type="checkbox"/>

No Raft: Print without raft.

No Support: Print without support.

Stable Support: Support structure will be stronger but harder to be removed.

Others	
Unsolid Model	<input type="checkbox"/>
Thin Wall	<input type="checkbox"/>
Preheat	<input type="checkbox"/>

Unsolid Model: The software will autofix nonsolid models.

Thin Wall: The software will detect the wall thickness that is too thin to print and expand the wall to a printable size.

Preheat: Preheat the build plate for maximum 15 minutes before printing starts.

Printing Parameters

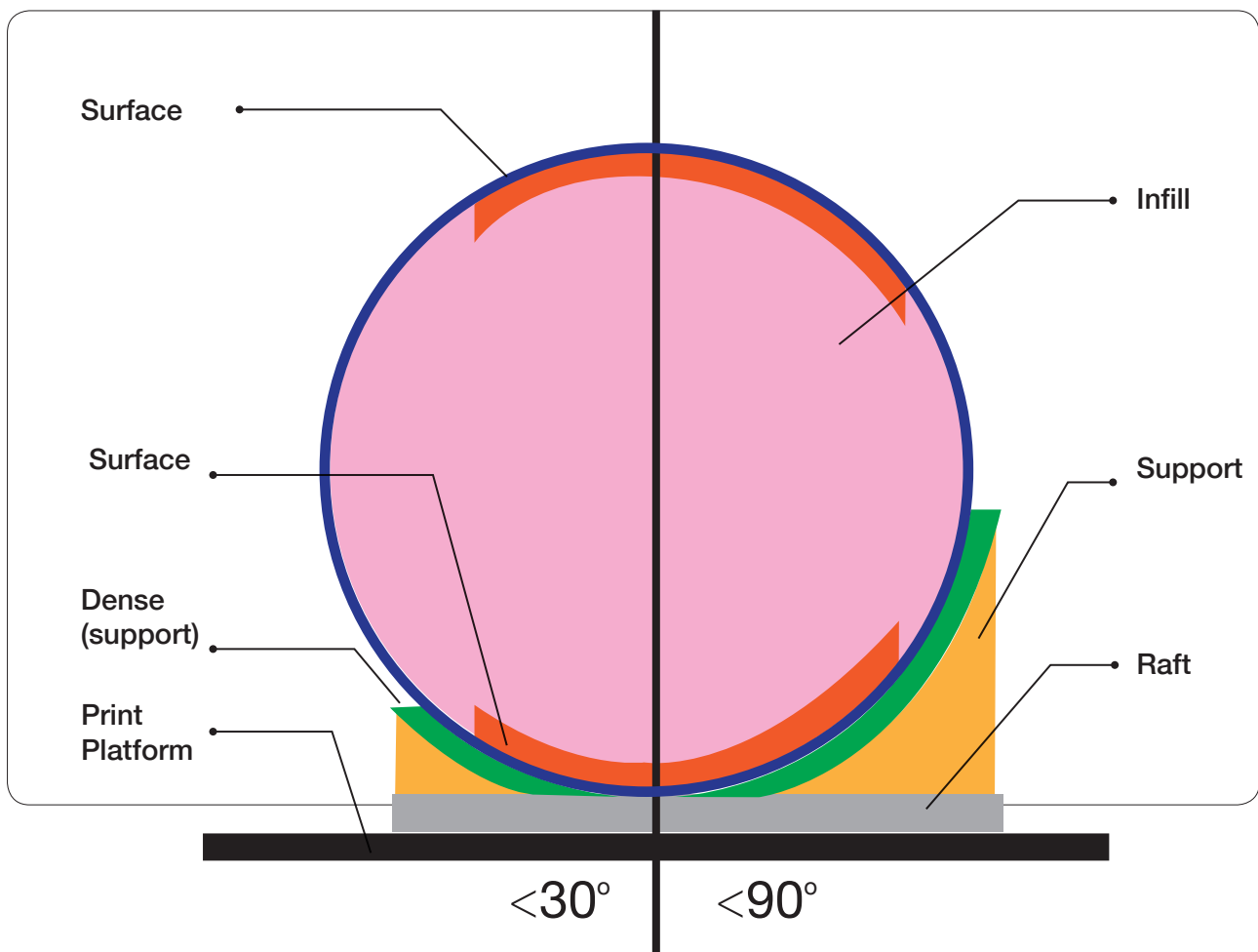

Dense: Solid support structure ensures that the surface being supported retains its shape and surface finish.

Infill: The inner structure of the printed object. The density of the infill can be adjusted.

Raft: The thick structure that assists with the adhesion of the object to the platform.

Surface: The top and the bottom layers of the printed object.

Using Customized Material Profile

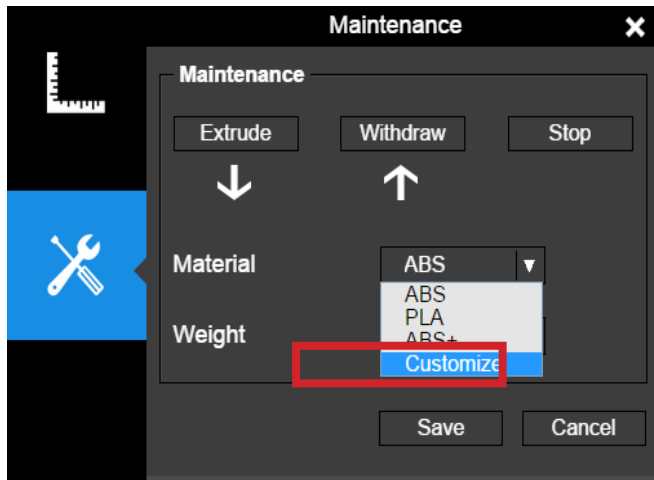

It is possible to use customized material profile to control the printing temperature and platform temperature. This function is very useful for using third party materials that cannot print well using the preset profiles.

To use the customized profile, go to Maintenance and choose "Customize" in the material list.

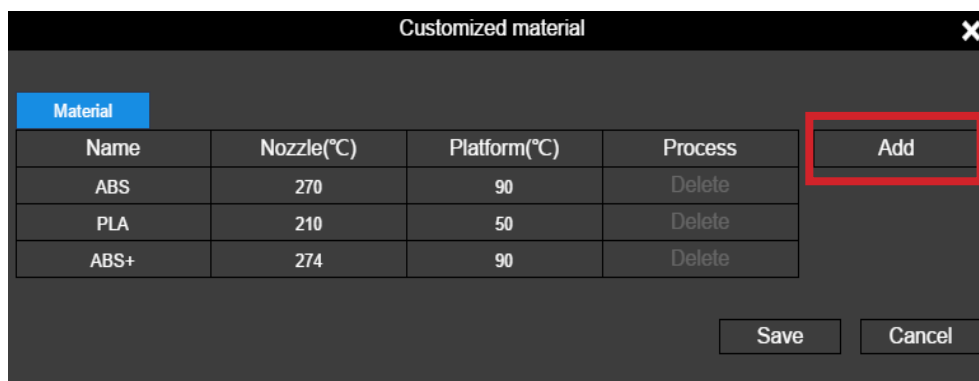

Click "Add" to add customized profile.

Name	Nozzle(°C)	Platform(°C)	Process
ABS	270	90	Delete
PLA	210	50	Delete
ABS+	274	90	Delete
			Delete

Input profile name, nozzle temperature and platform temperature.

Converting a 2D Picture Into a 3D Model

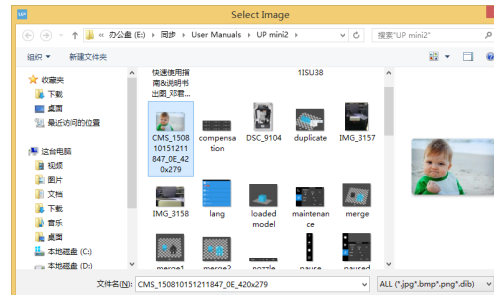
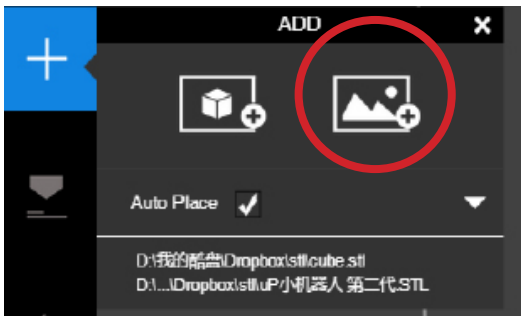

Click the "Add Picture" button and select a picture.

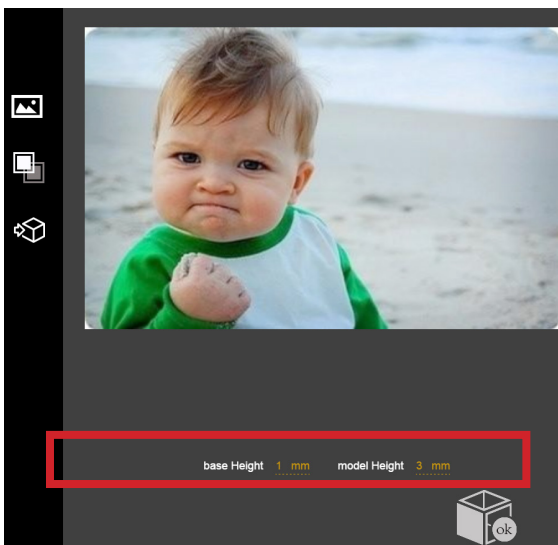

Base Height determines the thickness of a flat layer that holds the picture.

Model Height determines the contrast of the final print.

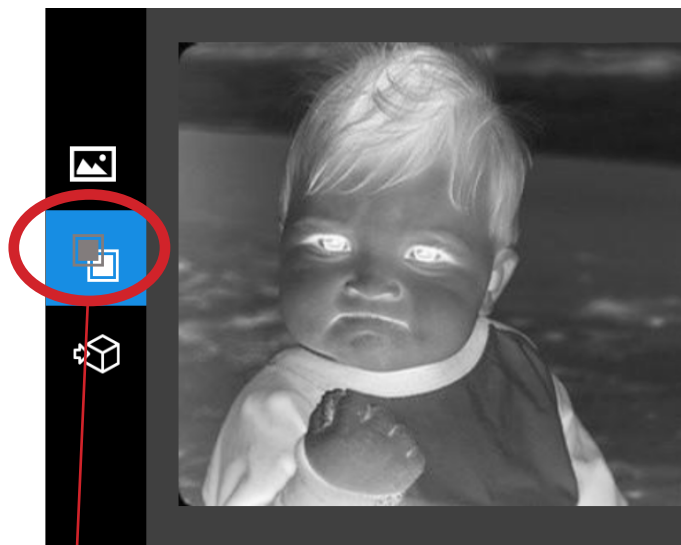

The "Convert Negative" button will reverse the pixel intensity so that user could choose the picture to be protruding from or sunken into the base.

Converting a 2D Picture Into a 3D Model

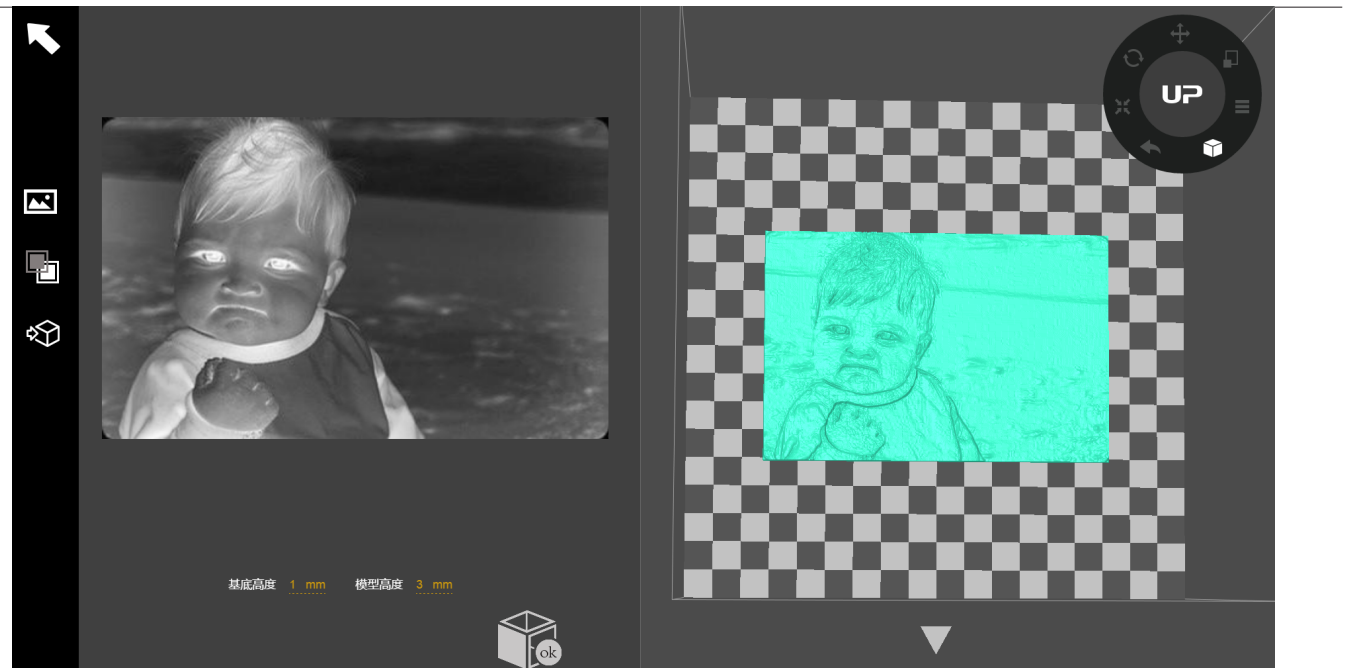

Update 3D model button. This button will convert the modified picture on the left to a 3D rendering on the right.



OK button sends the 3D rendering to the 3D printing interface for printing.

Machine and Software Settings



Click the "Setting" button to bring up the menu



Choose a Language



Choose and Set the Printer's Name

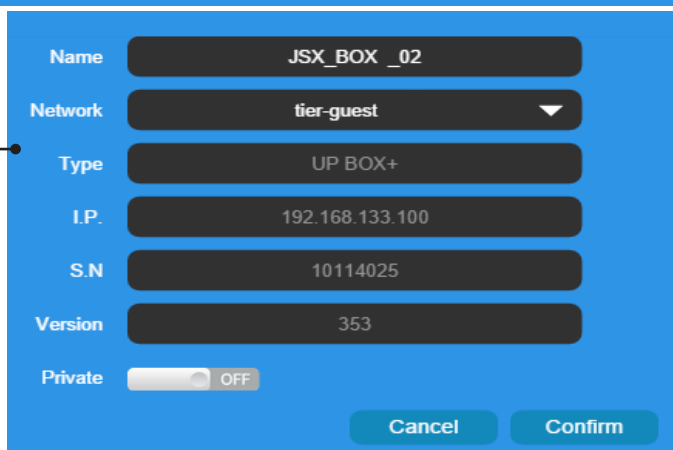

Printer Name and Wi-Fi Settings

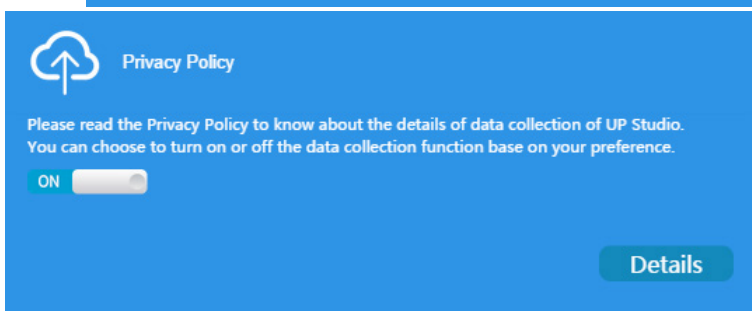

Privacy Setting

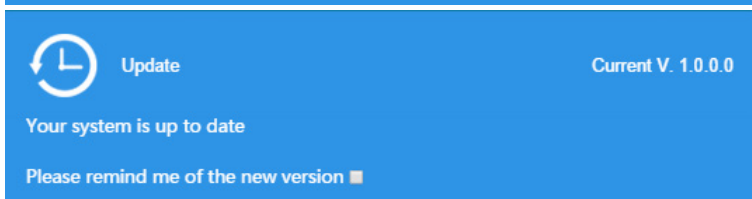

Auto Update Setting

Controlling Multiple Printers with USB

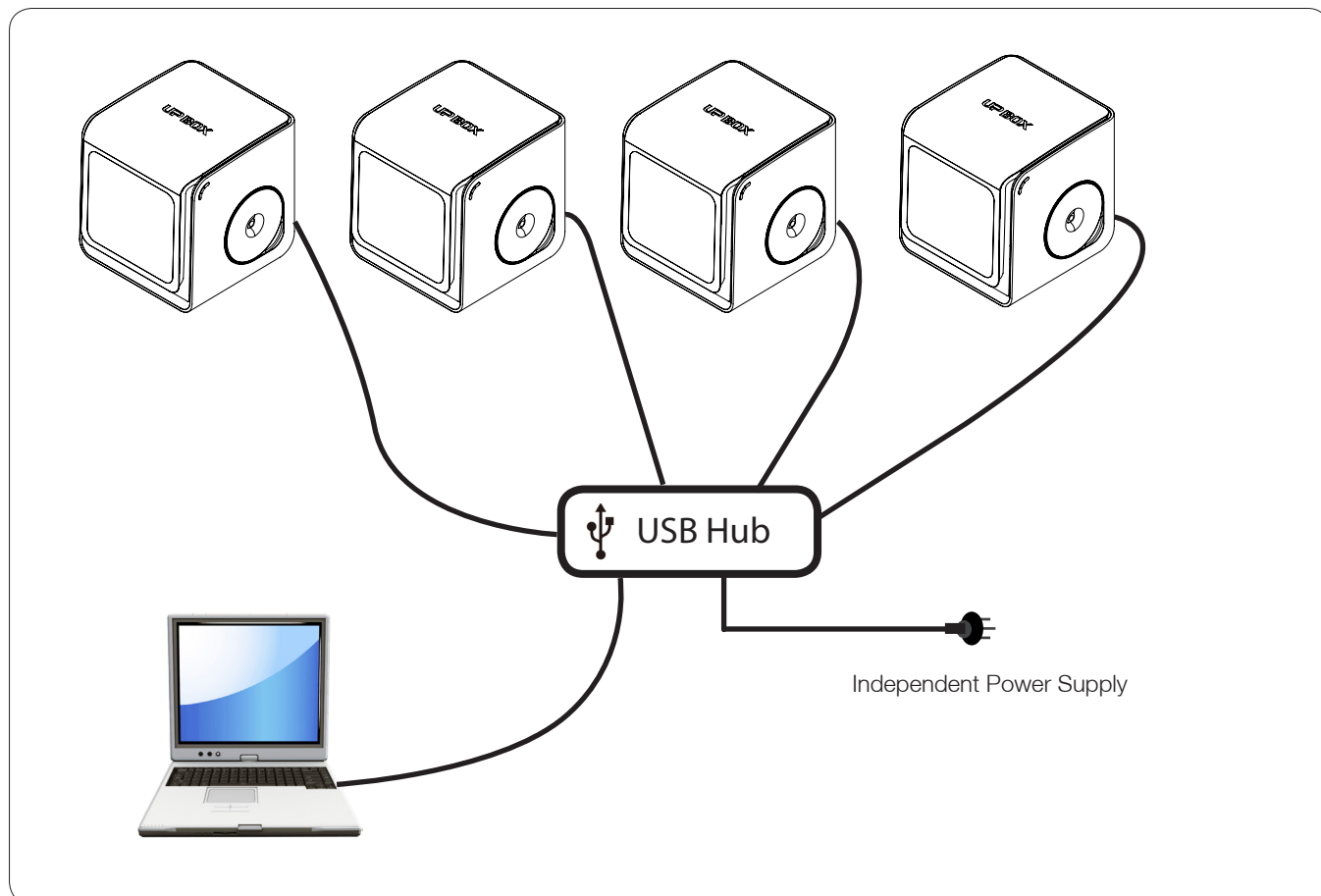

Multiple printers can be controlled by a single computer one at a time through Wi-Fi or a USB hub. A USB hub with independent power supply is recommended to ensure stable connections.

Printer Info and Naming a Printer



User could rename the printer by clicking the printer name on the status bar.

Printing Techniques

1. Ensure accurate nozzle height.

If the nozzle height value is too low, it will cause warping; if it is too high, it will crash the nozzle into the platform, causing damage and clogging. You can manually fine-tune the nozzle height value in the "Calibration" section. Try to adjust the nozzle height value plus or minus 0.1 –0.2mm from the base on previous results.

2. Level platform well.

An unlevelled platform usually causes warping. Allow enough time for sufficient pre-heating. Please use the pre-heat function in the under the Print section. A well preheated platform is essential for printing large objects without warping.

3. The airflow on print head is adjustable turn the air flow adjustment knob to change the amount of cooling of printed object. Generally the more cooling provided, the better the print quality. Cooling also help separate from support and raft. However cooling also encourage warping, especially for ABS.

To generalize, PLA can take strong cooling without problem, while ABS should avoid cooling or give little cooling. For ABS+ medium cooling is recommended.

Increased cooling will also improve print quality of fine and overhang structures. Here are some examples.

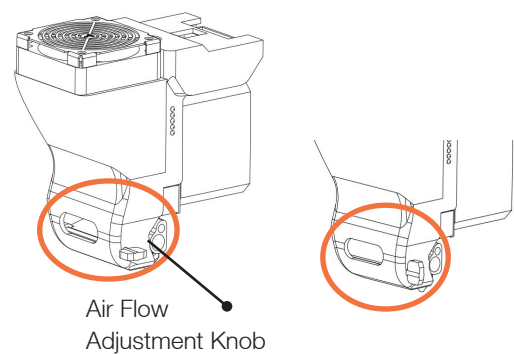

Fan duct closed

Fan duct fully opened

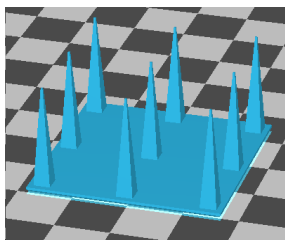

Fine structures

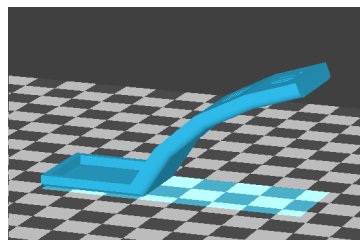

Overhang

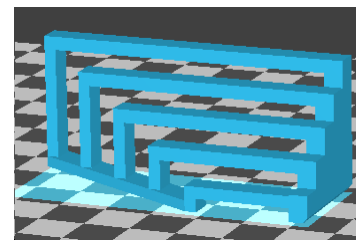

Bridging

4. Printing with no raft

It is highly recommended to use raft for normal printing as it improves adhesion and is required for leveling compensation. It is turned on by default, but you can turn it off in the "Print Preference" panel.

5. Printing with no support

It is possible to print without supporting structures. You can turn off support by choosing "No Support" in the "Print Preference" panel. However support will still be generate up to 10mm to provide a stable base.

Fine Manual Calibration

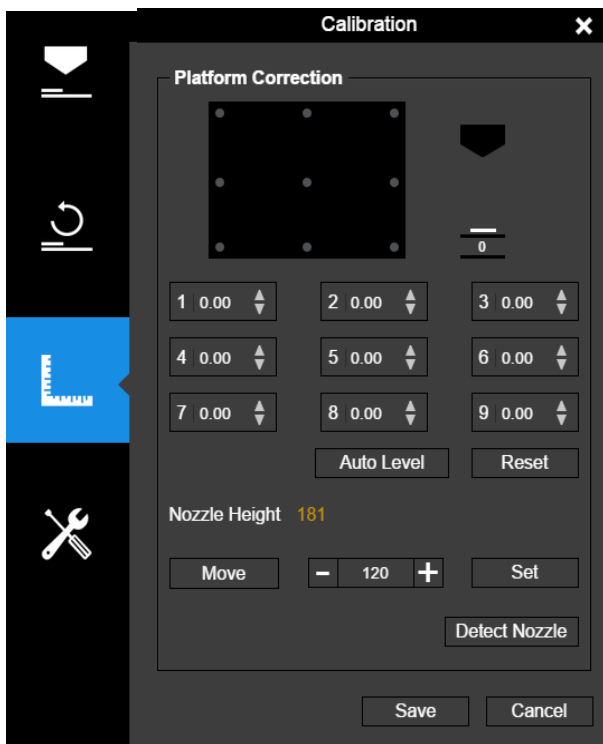

- ① Initialize the printer
- ② Open the calibration interface. Press the "Reset" button to set all the compensation values to zero.



- ③ Press button 5 to move the print head to corresponding position. Then press the "+" button to raise the platform.

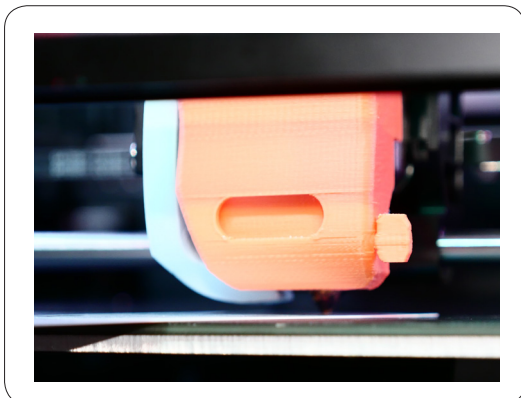

- ④ Raise the platform until it is just touching the nozzle. Put Calibration Card between the nozzle and the platform, move the Calibration Card to see if there is any resistance.

To learn more about how to use calibration card please go to our website (up3d.com) to get the latest software and user manual.

5

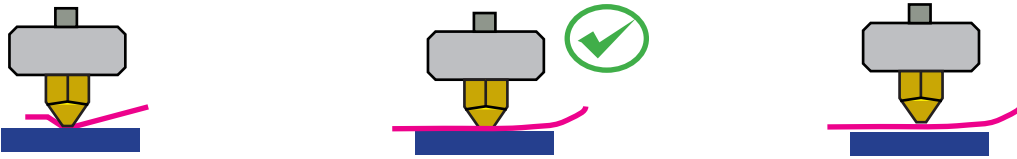

The platform is too high. The nozzle is pinning the Calibration Card onto the platform. Lower the platform slightly.

The height is just right. Can feel some resistance when moving paper.

The platform is too low. No resistance is felt at all when moving the paper. Raise the platform slightly.

6 When the ideal platform height is obtained, note the value of the "Current Height". This is the platform height value. Repeat steps 1 –6 for all of the other eight positions and note their platform height values.

Platform Values at 9 calibration points (hypothetical):

1: 208	2: 208.5	3: 208.7
4: 208.6	5: 208.9	6: 209
7: 208.8	8: 208.9	9: 208.8

7 When you have obtained the platform height values for all nine positions, find the lowest value among the values.

In this example, the first calibration point has the lowest value and is thus the highest point on the platform. (The highest point of the platform require minimum amount of travel to reach the nozzle).

8 Type 208 in the text field and click "Set" to set nozzle height to 208.



Setting Compensation Values

As shown on the left, when the platform is at the "nozzle height", only part of the platform is close enough to the nozzle. Therefore, you need to set the compensation values for all of the other calibration points to inform the printer about the distance between the nozzle and the print surface throughout the XY plane.

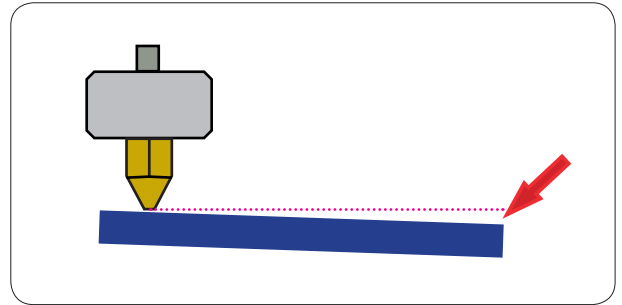

After setting the nozzle height, the drop-down menu next to the nine position buttons will be available.

A compensation value between 0–1.0mm will be available for selection.

To calculate the compensation value:

Platform Height - Nozzle Height = Compensation Value

For example: setting the compensation value for calibration point 3. Assume the "platform height" is 208.7 and the "nozzle height" is 208. The compensation value should be set to 0.7. After setting 0.7 for compensation, the nozzle will move to point 3 and the platform will rise 0.7mm. Now use the Calibration Card again to verify the space. After setting all calibration points, click "Save" to finish the calibration.



Maintenance

Removing the nozzle. After a long period of printing, the nozzle can become very dirty or even clogged. You can replace it with a new one while the old one is cleaned for reuse:

1. Use the "Withdraw" function in the "Maintenance" panel. The nozzle will heat up to the printing temperature.
2. Wear the heat-resistant gloves provided in your printer kit and wipe the nozzle with tissue or cotton.
3. Unscrew the nozzle using the wrench provided in your printer kit.
4. Remove the clog using any of the many methods to do so, such as drilling through the clog using a 0.4mm drill bit, submerging the nozzle in acetone, or using a heat gun to melt and blow away the clog.

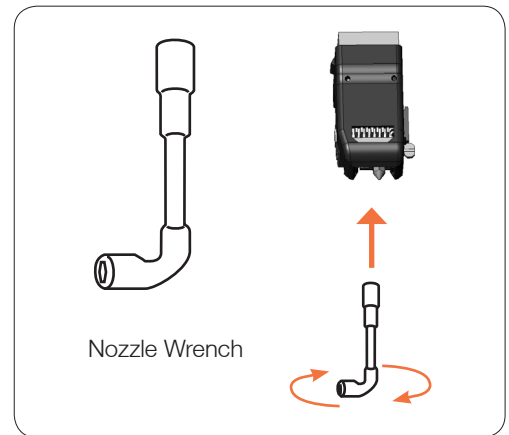

Replace the Air Filter

Turn clockwise to install the cap.

Turn anti-clockwise to remove the cap.

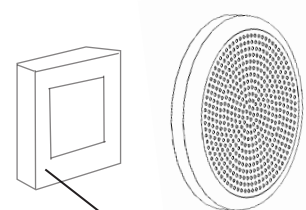
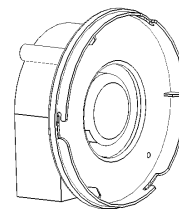
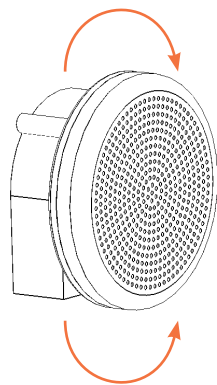

Filter Cartridge

It is recommended to replace the filter for every six months or after 300 hours of printing (whichever comes first).

Moving the Platform Manually

Under certain circumstances, users may need to move the platform up and down manually. This could be done by turning the Z-axis lead screw with a slot screw driver.

We do not recommend pressing or lifting the platform with brute force, as the platform could be damaged or unlevelled.

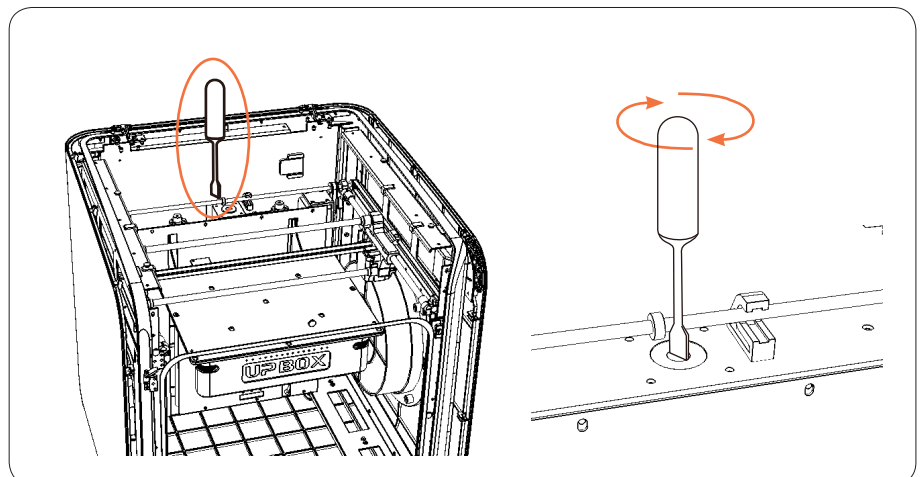

Filament Check

When run out of filament during a print, the printer will be paused automatically, wait for the user to refill and continue. Refer to page 15 for how to refill and resume printing.

Blackout Recovery

A print job could be resumed after an electricity cutoff. The next time when the printer connects to a computer and after an initialization, a pop up window will appear to let the user choose to resume the interrupted print job.

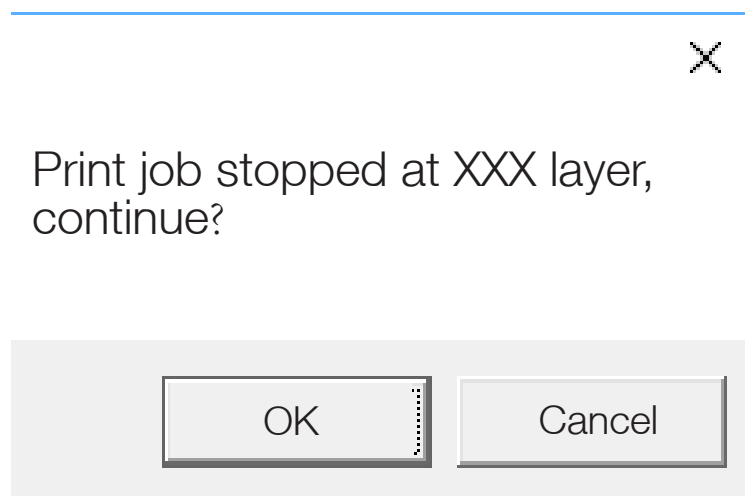

Troubleshooting

Problems	Solution
Printing or platform cannot reach target temp or over heat.	Initialize the printer.
	The heater cartridge may be broken. Replace the cartridge.
	The heater cable may be broken. Replace the cable.
The filament won't extrude.	Withdraw the filament from the print head. Cut off the melted tip and reload it into the print head.
	There may be plastic clogged in the nozzle. Replace the nozzle or remove the clog.
	The filament may be too thick. This usually happens when using a filament of poor quality. Please use UP brand filament for quality assurance.
	For some printer models, PLA can present a consistent issue. Switch to ABS
My computer won't detect the printer.	Make sure the printer drivers are installed correctly.
	Check for and replace a defective USB cable.
	Restart both the printer and your computer.
Others	Contact our technical support: support@pp3dp.com

UP BOX+ Specifications

Printing Technology	MEM (Melted Extrusion Modeling)
Build Volume	255 x 205 x 205mm (W x H x D) 10" x 8" x 8"
Print Head	Single, Modular for easy replacement.
Z-Resloution	0.1/0.15/0.20 /0.25 /0.30 /0.35 /0.40 mm
Supporting Structure	Smart Support Technology: automactically generated, easy to remove, fine-tunable.
Platform Leveling	Fully automatic leveling with integrated leveling probe.
Build Surface	Heated, UP Flex Print Board, Perforate Print Board
Unterthered Printing	Yes
Average Operational Noise	51dB
Advanced Features	Door Sensor, Blackout Recovery, Air Filtration, Full-Color LED Bar
Bundled Software	UP Studio, UP Studio App
Compatible File Formats	STL, UP3
Connectivity	USB, Wi-Fi
Operating System	Win Vista/7/8/10, Mac OSX, Mac IOS
Power adapter	110-240VAC, 50-60Hz, 220W
Chassis	Plastic case with metal frame, enclosed
Printer Weight	20KG / 44 LB
Printer Dimiension	493 x 493 x 517 mm (L x W x H) 19.5" x 19.5" x 20.5"
Weight with Packaging	30 Kg
Packaging Dimension	590 x 590 x 650mm (L x W x H); 22.4" x 22.4"x 24.8"



Tiertime
太尔时代