



Thermostat install guide



By  British Gas

Install Guide

For Hive Active Heating™ the thermostat, receiver and hub are installed together so heating and hot water can be controlled remotely. If this wasn't the product purchased, the thermostat and receiver can also be installed without a hub, in 'standalone' mode for local only control.

Installation should only be carried out by a qualified engineer, see page 5.

Installation order:

For quick and efficient setup install Hive Active Heating™ in the order shown below.

1

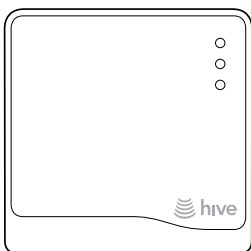

Install hub

Wait until the hub flashes amber

2

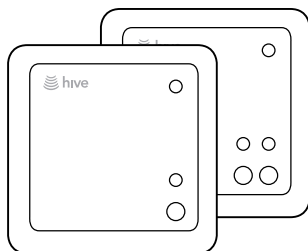

Install receiver

Wait until the status light flashes amber

3

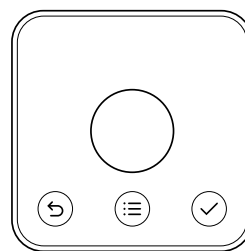

Add thermostat

It will show 'searching' and then connect

4

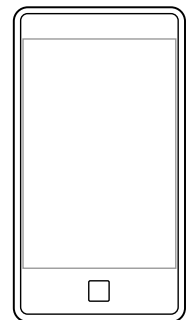

Complete online setup

On the Hive website or mobile app

1 – The hub

To install the hub there must be a broadband connection with a spare network port and a power socket must be nearby. Once this has been located, connect the hub as follows:

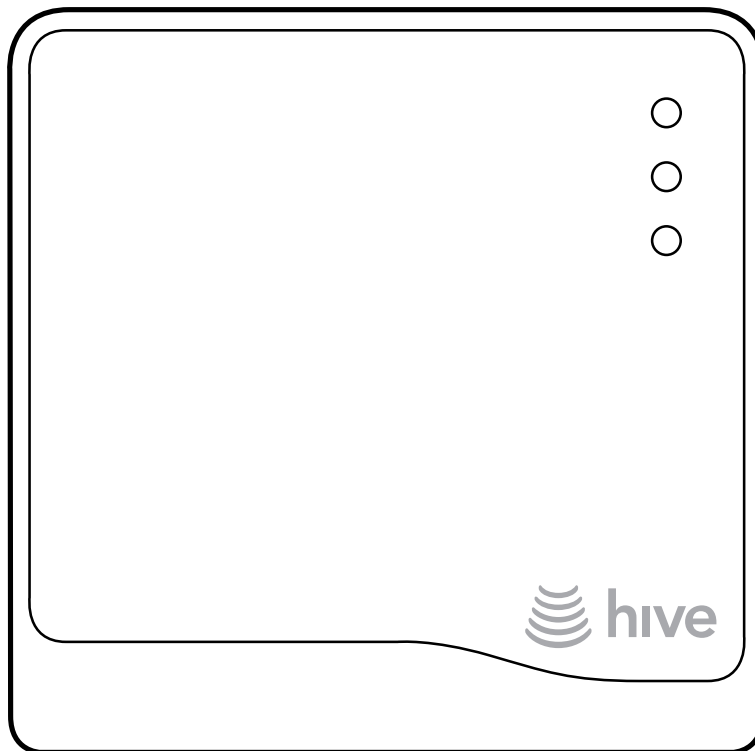

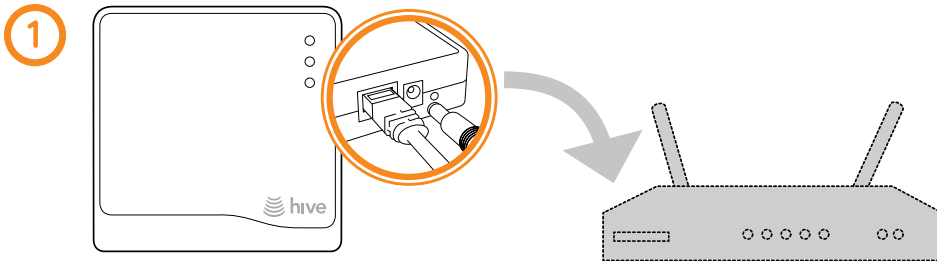

1 Connect the hub to the household's broadband router using the network cable provided.

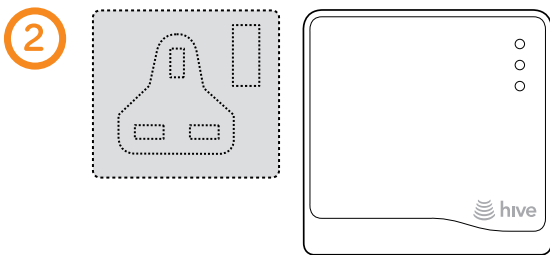

2 Fit the power cable into the hub and plug it into a power socket.

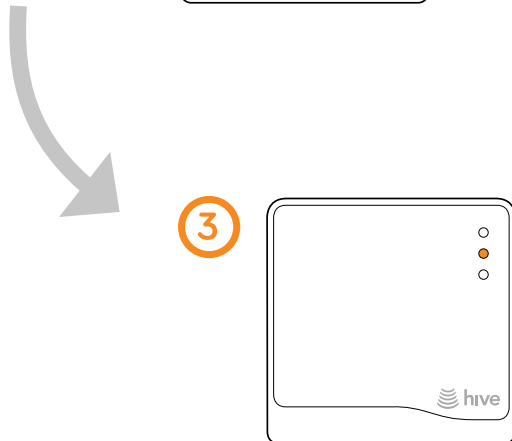

3 Wait for an amber flashing light. During start up the green light will flash, followed by the amber light. This usually takes 5-10 minutes.

1a – Connecting the hub

Once the amber light is flashing, the hub is set up and you can move onto installing the receiver. If no lights are displayed immediately after the hub has been turned on, check all cables are connected and the power socket works. If the problem still persists contact Hive Technical Support.

Hub lights and what they mean

Colour	Pattern	What does this mean?	Notes
Green	Flashing	Installation and start-up. The hub is attempting to connect to the Hive servers and update itself.	Do not disconnect the hub. If flashing continues after 15 minutes, contact Hive Technical Support to confirm that it has connected.
Amber	Flashing	Installation. The hub is actively seeking to connect to the receiver and thermostat.	The hub will search for devices for 2 hours at a time. It will then pause, and show solid amber.
Amber	Solid	Installation. The hub has paused its search for other devices.	To restart the search, simply turn the hub off then on. The amber flashing light should then return.
Green	Solid	Normal operation. The hub is connected.	This happens once the hub, receiver and thermostat are all installed and synchronised.
Red	Solid or Flashing	Error. The hub has failed to connect to the Hive servers.	Check that the hub is plugged in and that the broadband is working. If the problem persists, call Technical Support.

2 – The receiver

Important information before you get started

- Before fitting, isolate the mains electricity supply to the central heating system. Confirm it is isolated and secured in the off position for the duration of the installation. Remember to always follow appropriate safe electrical isolation procedures and test to confirm that the supply is isolated before touching any electrical connections.
- This product should only be installed by an electrically skilled person competent in the installation of electrical accessories. The wiring must comply to the current edition of BS7671 (The IET Wiring Regulations), and the appropriate Building Regulations or Standards in place.
- The Hive receiver is double insulated so doesn't need an earth connection. You'll find a tether on the backplate to secure an earth wire if needed.
- **This product is designed for fixed wiring installation only. It must be supplied via a switched fused spur with a minimum contact separation of 3mm (both live and neutral) and fitted with a 3A fuse.**

Installing the correct receiver

Hive Active Heating™ has two types of receiver:

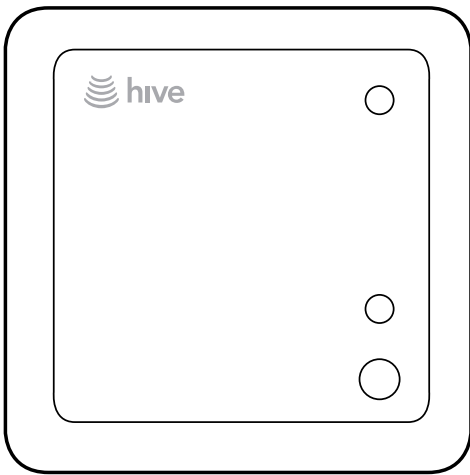

Single channel receiver
for combi boilers



Dual channel receiver
for conventional boilers
with hot water cylinders

Wiring labels

Before you start, use the labels provided and attach them to the wires. Taking a photo of the wires can be a handy reminder.



2a – Installing the receiver

You should fit the receiver in a convenient location close to the boiler or central heating system. **Make sure it's at least 30cm away from large metal objects**, such as a boiler or hot water cylinder, to avoid interference with radio signals. Take care to avoid any cables and pipes that may be buried in the walls. Once you've found a suitable location, install the receiver as follows:

1

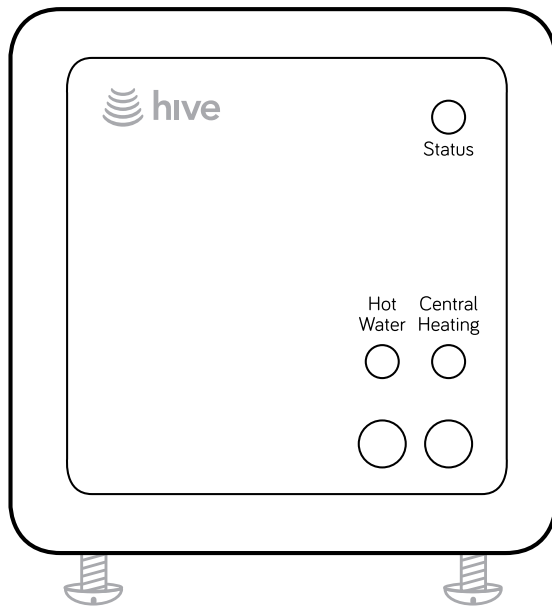

Loosen the screws on the underside of the receiver and remove the backplate by pulling the bottom of it away from the front panel.

2

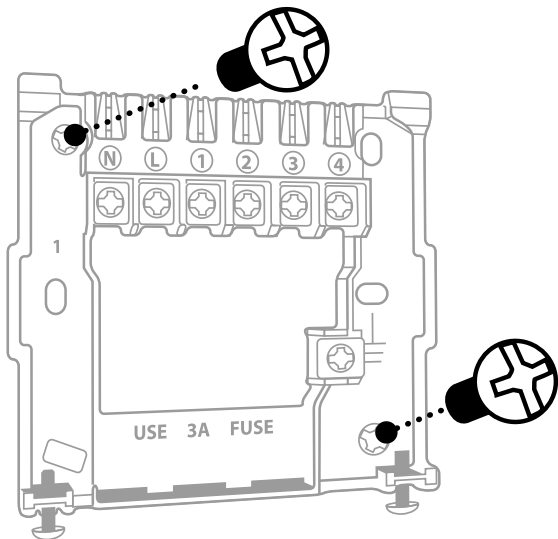

Fix the backplate to the wall with the terminals at the top.

3

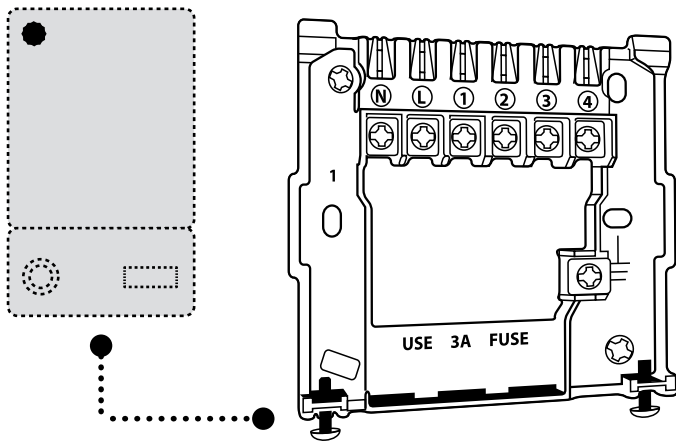

Run cable from the boiler or wiring centre (if required), then continue on to the next section to wire up the backplate.

2b – Single channel receiver wiring

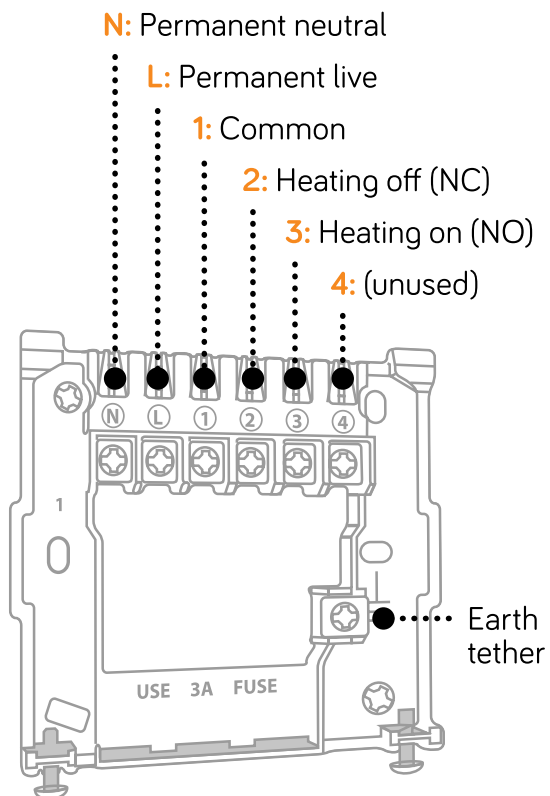

2b – Dual channel receiver wiring

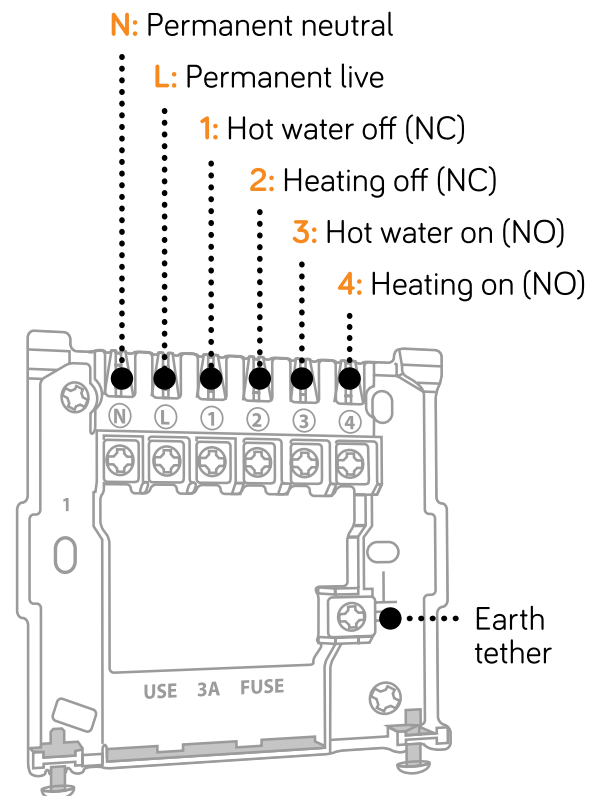

2c – Testing the boiler

To test the receiver to boiler connection follow these steps:

- ① Visually check the wiring to confirm that the connections have been carried out correctly, referring to the labels on the wires and any photographs taken before replacement began.
- ② Confirm that the receiver's front panel is in place and that it is safe to commission the boiler.
- ③ Restore power to the central heating system – the receiver's status light should flash amber. This means it's ready to connect to the hub and thermostat.
- ④ Test the receiver's wiring to the heating system by pressing the 'Central heating' button. The green light above the central heating button should come on and the boiler should fire up.

Once you've completed these tests leave the receiver switched on with the status light flashing – this means it's ready to connect to the hub and thermostat. Next install the thermostat.

Important information: Replacing existing controls

If there's an existing single zone timer or wireless receiver, you should replace it with the Hive receiver. Hive receivers are backplate compatible with a number of common boiler controls that may already be fitted in the home.

If the existing controller **doesn't** have a compatible backplate, remove it completely and wire in the Hive receiver in its place. If needed you can use a stand-off plate (SP, supplied separately) to create space to accommodate existing wiring, or use a decoration plate (DP) when replacing a larger controller.

If the existing controller **does** have a compatible backplate, simply remove the front panel of the existing controller and snap the Hive receiver front panel on in its place.

- **Single channel receiver compatibility:** WR1 receiver, UT2 and EMT2 timers
- **Dual channel receiver compatibility:** UP2 and EMP2 programmers

Important information: Replacing an existing thermostat

If you're replacing an existing wired thermostat, you should ensure that the pre-existing wires and connections are made safe. This can be achieved by disconnecting or bridging out the wired thermostat in the wiring centre or boiler. Where cables are left at the wireless thermostat position, they should be housed and terminated within an enclosure to prevent access. If you're replacing an existing wireless thermostat, decommission it by detaching it from the wall and removing its batteries.

Important information: Gravity-fed and part-pumped systems

Gravity-fed and part-pumped systems are wired differently to standard boilers. With these, the hot water relay switches on the boiler, whilst the heating relay opens a valve, operates a pump, or both, to divert hot water to the heating. If you are installing into a gravity-fed or part pumped system, complete the wiring and then switch the Hive receiver to 'gravity-fed' mode as follows:

- ① Switch off the power to the boiler and receiver.
- ② Wait at least 5 seconds, then switch the boiler and receiver back on.
- ③ Press and hold the hot water button for at least 10 seconds.

The receiver status light will flash BLUE for 3 seconds when entering 'gravity-fed' mode. Or GREEN for 'fully pumped' mode. Fully pumped mode is the default for new devices.



Important information: Stand-alone installation

For Hive Active Heating™ a hub, a receiver and a thermostat are installed. When this service hasn't been bought, the thermostat and receiver can also be installed without a hub. This is known as 'stand-alone' mode.

Follow the steps in the next section if the thermostat and receiver are going to be installed without a hub in 'stand-alone' mode (where Hive Active Heating™ hasn't been purchased).

In 'stand-alone' mode the thermostat acts as a standard wireless programmable thermostat without the remote heating control features and functionality of Hive Active Heating™.

Activating stand-alone mode

- ① Remove the batteries from the thermostat.
- ② Switch off the boiler and receiver.
- ③ Wait at least 5 seconds, then turn the boiler and receiver back on. The receiver's status light will begin to flash amber.
- ④ Press and hold the heating button for at least 10 seconds – until the status light begins to flash white. The receiver is now in 'stand-alone' mode and is searching for a thermostat.
- ⑤ Insert the batteries into the thermostat, press and hold down the menu  and back  buttons on the thermostat and follow the factory reset instructions on screen. After about 10 seconds, 'Welcome' and 'Searching...' will be displayed on screen. If the thermostat shows 'REJOIN' then try steps 1 and 5 again.

To switch back to 'remote heating' mode:

- a. Switch the hub off and then on again. If it begins to flash amber continue on to step b. If all the lights go out and the hub does not flash amber, log into hivehome.com, open the 'Devices' page and click 'Add devices'. The hub should now begin to flash amber.
- b. Now follow steps 1-5 above, but note that the lights will be different. At step 3 the receiver's status light will initially flash white/pink and in step 4 it will change to amber (for 'remote heating') once you have held the Central heating button down.

At any time you can check what mode the receiver is set to by switching it off then on. When power is restored the status light will flash for 5 seconds – amber for Hive Active Heating™, white for 'stand-alone' mode.

Receiver lights and what they mean

The receiver has lights on its front panel to show what it's doing. A single channel receiver has two lights – 'Status' and 'Central heating'. A dual channel receiver has an additional light for 'Hot water'. This is what the lights mean:

Light	Colour	Pattern	Meaning	Notes
Central heating	Green	Solid	Heating is on.	
Central heating	Green	Flashing	Commands queued. The receiver has received 2 or more commands to switch the boiler on or off within 1 minute. Or, Heating Boost mode with target temperature lower than room temperature.	The Hive receiver protects the boiler from damage that may occur if it's switched on and off very quickly. Once the boiler has been switched on (or off), it will not change state again for 1 minute as a protective measure.
Hot water	Green	Solid	Hot water is on.	This light is only present on dual channel receivers.
Hot water	Green	Flashing	Commands queued. The receiver has received 2 or more commands to switch the boiler on or off within 1 minute.	See 'Central heating'.
Status	Green	Solid	Normal operation. The receiver is connected to the rest of the Hive system and operating normally.	

Light	Colour	Pattern	Meaning	Notes
Status	Blue	Solid	The system is in gravity-fed mode and is connected to the rest of the Hive system.	See gravity-fed mode section of this manual.
Status	Amber	Flashing	Installation. The receiver is trying to connect to other Hive devices.	The receiver will search for devices for 40 minutes at a time.
Status	White	Flashing	The receiver is in stand-alone mode and is actively seeking to connect to a Hive thermostat.	The receiver will search for a thermostat for 40 minutes. If no thermostat is found within this time it will stop searching and the status light will turn solid white.
Status	Amber or white	Solid	Installation. The receiver has paused its search for other devices.	To restart the search, simply turn the receiver off and then on. This will return it to the amber or white flashing state.
Status	Red	Solid	Error. The receiver has lost its wireless connection to the thermostat.	Whilst in this state heating and hot water will default to off. They can be switched on manually by pressing the 'heating' and 'hot water' buttons on the receiver (hot water only available on dual channel receivers). Call Hive Technical Support to resolve the issue.

3 – The thermostat

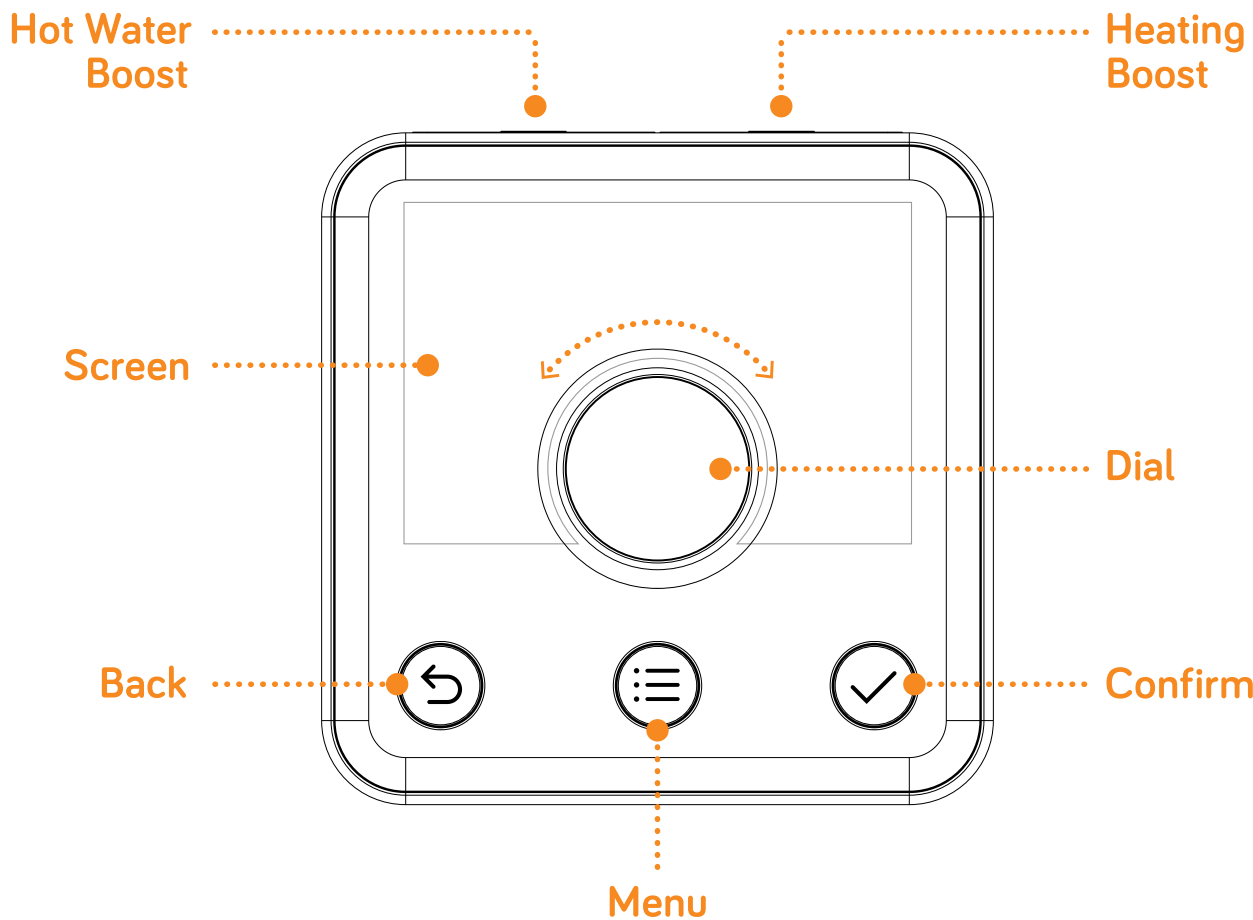

For the thermostat to work accurately it's important that you install it in the right location.

3a – Selecting a location for the thermostat

The thermostat should be fixed to an internal wall, 1.5m from the floor and away from heat sources that could affect its operation, such as radiators and areas in direct sunlight. To make accurate temperature readings the thermostat needs a free flow of air, so make sure it's installed in an area not covered by curtains or similar objects.

The thermostat should not be installed in the same room as a radiator that's controlled by a thermostatic radiator valve (TRV). Installing the two in the same room may result in the central heating being permanently on.

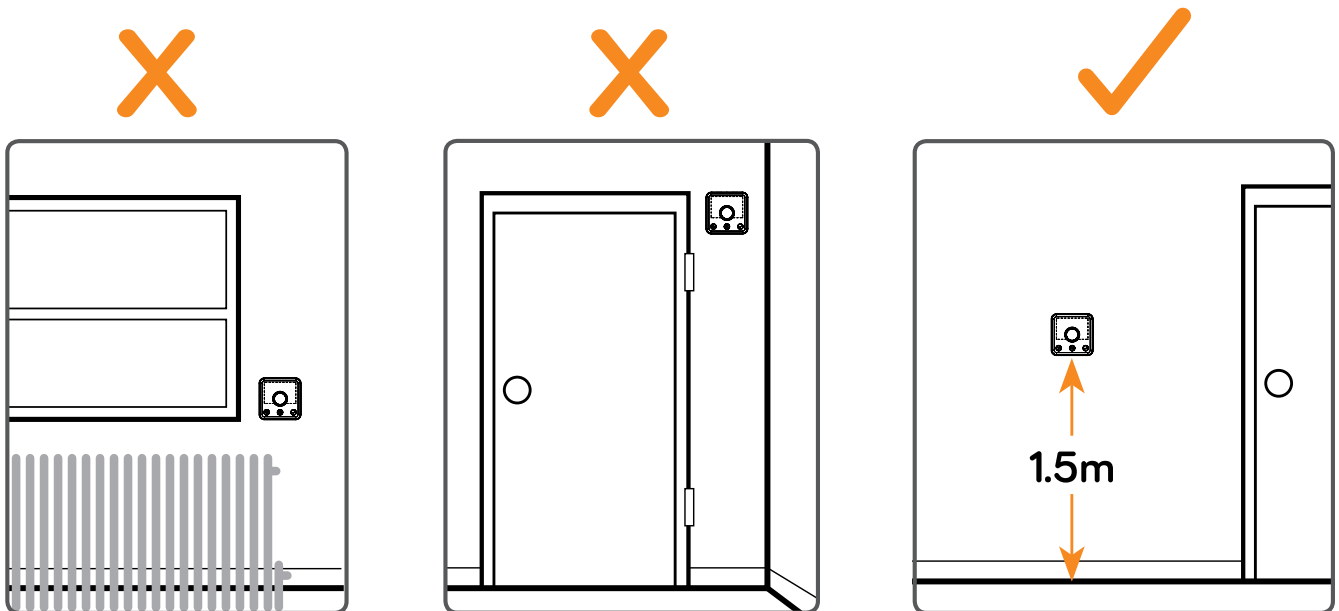

3b – Wall mounting the thermostat

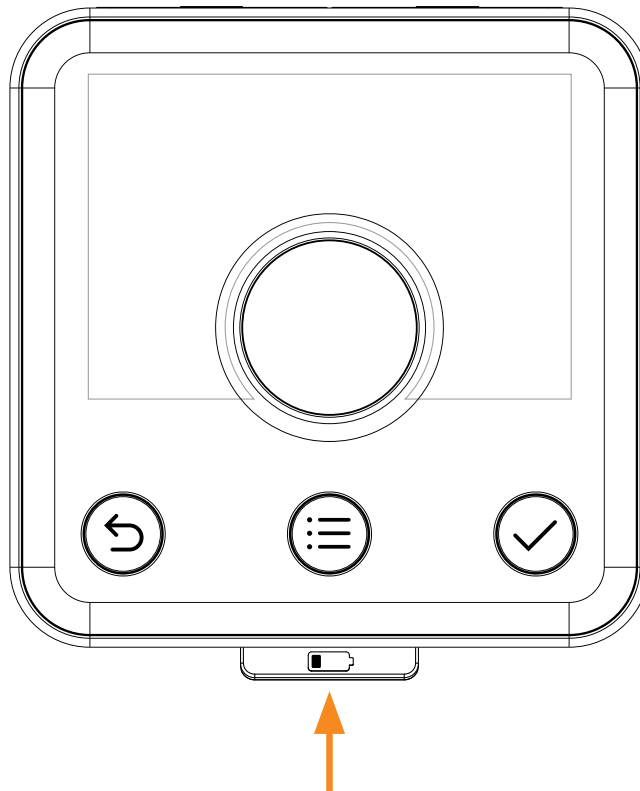

Remove the backplate of the thermostat by pressing the lever at the bottom and pulling away from the front of the device.

Once you've found a suitable location, fix the backplate to the wall using the appropriate fixings. The backplate is designed for 3.5mm/size 6 or size 8 screws. Be careful to avoid any cables and pipes that may be buried in the wall.

Note: the backplate is designed to mount directly onto a single gang back box, if available.

3c – Confirming the hub is ready to connect

Before inserting the batteries into the thermostat, check the hub is flashing amber – this means it's ready to connect. If it is showing a solid amber light, turn it off then on, and then switch the receiver and boiler off and then on again too. The hub should then begin to flash amber and be ready to connect.

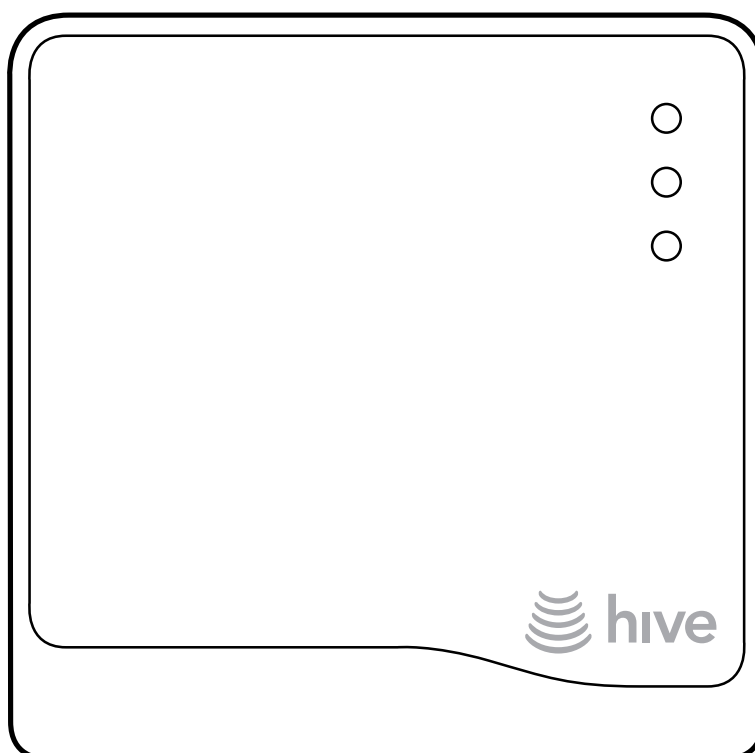

3d – Inserting the batteries and connecting to the hub and receiver

The battery compartment is located at the back of the thermostat and is only accessible when the front of the thermostat is removed from the backplate.

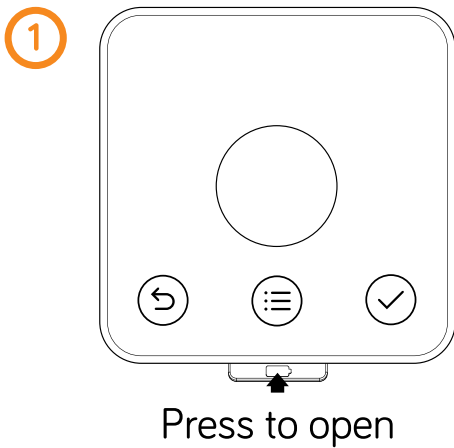

Insert four AA batteries.



The thermostat display will show 'SEARCHING' – meaning it's searching for the hub and receiver. A timer will show how long the thermostat has been searching. If this lasts for longer than five minutes contact Hive Technical Support and they will diagnose any problems.

3

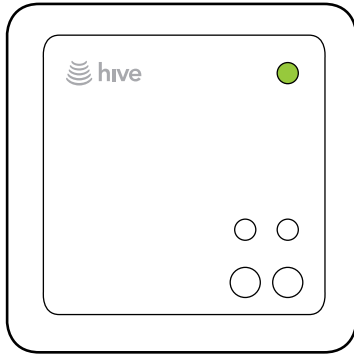

The receiver will display a solid green or blue status light and the hub lights will go green.

4



The thermostat will then go onto the 'Welcome' pages.

3e – Final steps

Installation is almost complete. All that's left to do is:

- ① Hook the thermostat onto the backplate and click it in place.
- ② Remove the screen protector from the front of the thermostat.
- ③ Confirm the system is properly configured by checking:
 - The thermostat is displaying room temperature.
 - The receiver's status light is solid green or solid blue.
 - The hub has solid green lights.

If the system is not properly configured it will not be possible to complete online setup.

4 – Online account setup

Hive Active Heating™ is now installed and ready to be registered. There are two ways to complete online setup:

Set up using a web browser

- ① Go to **hivehome.com**
- ② Log in using the account details supplied in the order confirmation email.
- ③ Enter the hub ID – this is the ABC-123 formatted number on the underside of the hub.
- ④ Once the hub ID has been entered, setup is complete and Hive Active Heating™ is ready to use.

Set up using the smartphone app

- ① Download the Hive app.
- ② Log into the app using the account details supplied in the order confirmation email.
- ③ Enter the hub ID – this is the ABC-123 formatted number on the underside of the hub.
- ④ Once the hub ID has been entered, setup is complete and Hive Active Heating™ is ready to use.

For Technical Support:

Visit hivehome.com/help

Email help@hivehome.com

This thermostat is a Class I temperature control and contributes 1% to seasonal space heating energy efficiency

Hive and the Hive logo are trademarks of GB Gas Holdings Ltd. Registered in England and Wales No. 03186121. British Gas is the trading name of British Gas Trading Limited, a Centrica company. Registered in England and Wales No. 3078711. The registered office of GB Gas Holdings Limited and British Gas Trading Limited is: Millstream, Maidenhead Road, Berkshire, SL4 5GD.

HIVE_WIRELESSINSTG_03.15